

# Ferrari

## 250 GTO



# Pack 01

## BUILD INSTRUCTIONS

**STAGE 01: THE FRONT BONNET  
AND STEERING WHEEL**

**STAGE 02: THE INSTRUMENT PANEL  
AND LEFT DOOR**

**STAGE 03: DASHBOARD, FLOOR AND GEARBOX**

**STAGE 04: FLOOR, GEARBOX  
AND CLUTCH BELL**

**STAGE 05: REAR FLOOR PAN  
AND DETAILS**

**STAGE 06: SEATS AND BELTS**

# Advice from the experts

---

To help you get the best out of building the Ferrari 250 GTO, we've prepared a modellers checklist with hints, tips and advice from our experts. The information below is aimed at making your build as enjoyable and professional as possible right from the start.

Have a soft cloth ready to place on your work surface to prevent scratching the paintwork.

Spare screws are included with each part. Occasionally, you may be instructed to keep spare or unused screws for a later stage. Keep these spares in a safe place and label them correctly.

Please make sure you don't mix up the screws. They look quite similar, but the threads do vary slightly. Using the wrong screws may damage the parts.

When securing parts together using multiple screws, fit each screw loosely to ensure all the parts are correctly aligned before gently tightening them firmly, but not overtight, in the order in which you placed them.

The screwdriver can be magnetized by stroking it with a magnet (fridge magnet, etc.) enabling it to hold the screws and make assembly easier.

If a screw is tight going into a metal part, do not force it as you may shear the head off. Remove it and put a tiny smear of Vaseline, soap or light oil on the thread. That will lubricate it and make it easier to drive home.

Only use the correct size screwdriver that fits the screw head firmly.

Use a magnet to help find screws that have fallen on the floor.

Use masking tape to hold parts temporarily in place.

Cut parts from a sprue (framework) with side cutters or a craft knife. Side cutters tend to be easiest.

During the course of this build, you will receive many pieces that you will assemble immediately – following the instructions in the corresponding stage – and other pieces that you should store safely to one side, for use in future assembly stages.

Left and Right! When building your *Ferrari 250 GTO*, the left- or right-hand side refers to that side as if you are sitting in the car.



**WARNING:** Some parts are assembled using magnets. These magnets can cause serious injury if they are swallowed. Keep away from children. If you suspect a magnet has been swallowed, seek medical help straight away.

All parts belong to a kit. Collectors item for adults.

Not suitable for children under 14.

Produced under license of Ferrari S.p.A. The name FERRARI, the PRANCING HORSE device, all associated logos and distinctive designs are property of FERRARI S.p.A. The body designs of the Ferrari cars are protected as Ferrari S.p.A. property under design, trademark and trade dress regulations.

# Stage 01: The Front Bonnet And Steering Wheel

The construction of your 1:8 scale model of the legendary Ferrari 250 GTO starts with the front bonnet and steering wheel.

Please be careful removing the steering wheel from its packaging as the parts are delicate.



## STAGE 01 PARTS LIST

Name	Name
1 Front bonnet	5 type A screws
2 Bonnet hinges	2 type C screws
3 Air intake covers	
4 Steering wheel	
5 Steering column	

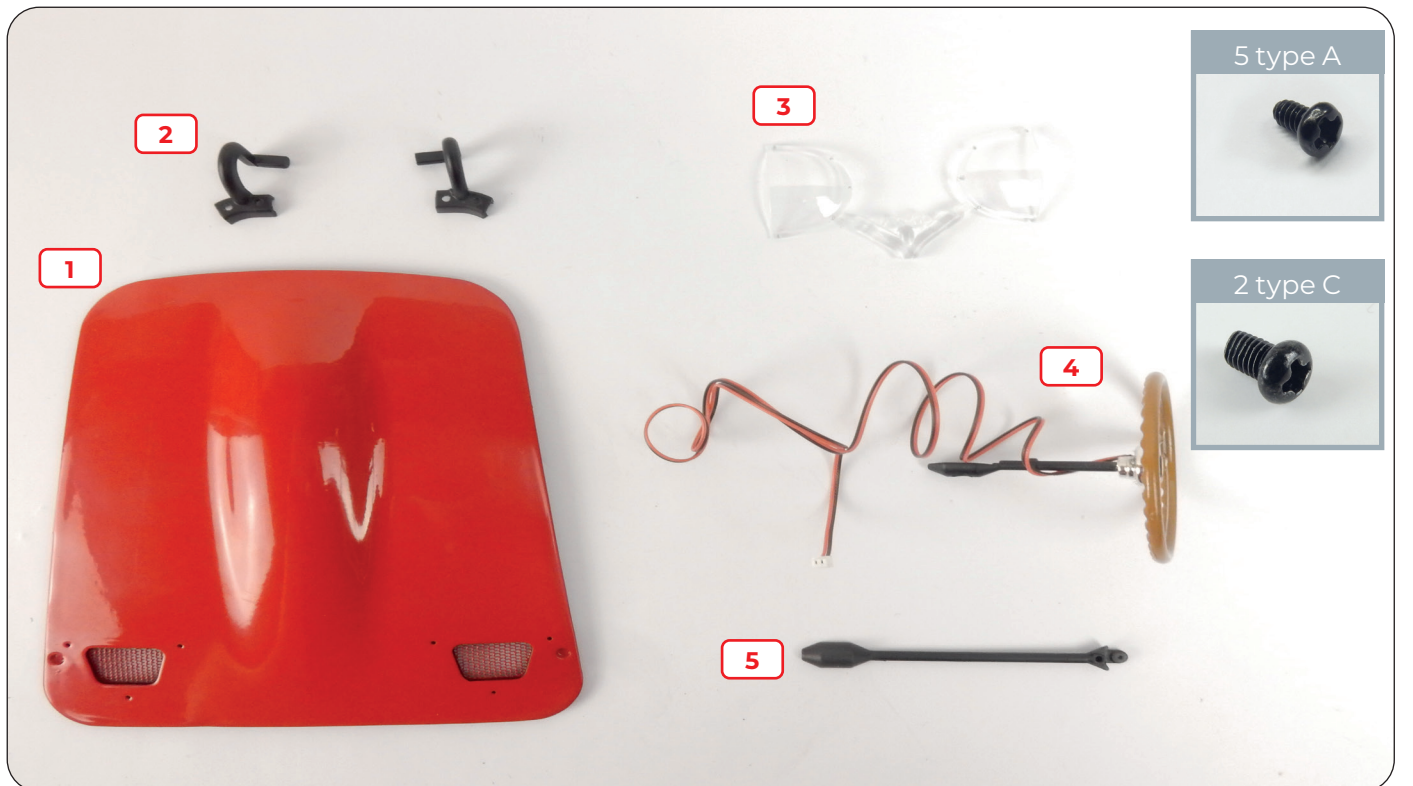

## Stage 01: The Front Bonnet And Steering Wheel



01/01 Arrange the front bonnet and the two hinges on your work surface. Use the photo to orientate the two hinges correctly.



01/02 Place the first hinge and secure it to the inside of the front bonnet with two type A screws.

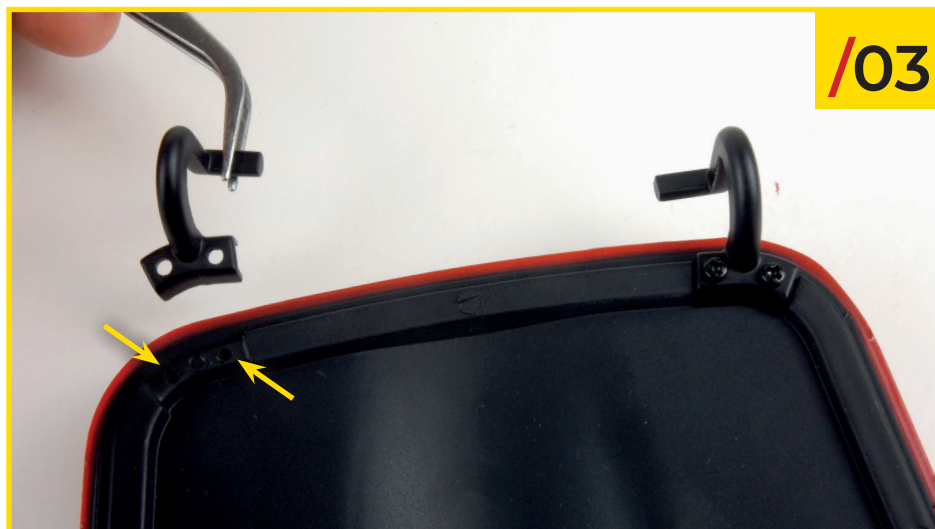

01/03 Do the same with the second hinge, positioning it as shown in the photo and securing it to the front bonnet with two type A screws.

01/04 Here are the two correctly installed bonnet hinges.



## Stage 01: The Front Bonnet And Steering Wheel

01/05 Now take the plastic air intake covers: you will notice the sprue is printed with the letters "L" (for "left") and "R" (for "right"). Separate the left air intake cover from the sprue.



01/06 Using tweezers, install the left-hand air intake cover on the bonnet. You will notice that these pieces are not symmetrical: use the photo to match the pins on the underside of the left cover to the corresponding holes. Press lightly to fit the two pieces together.

# Stage 01: The Front Bonnet And Steering Wheel



01/07 In the same way, install the right-hand air intake cover on the bonnet.

01/08 Now place the steering wheel and the column on your work surface.

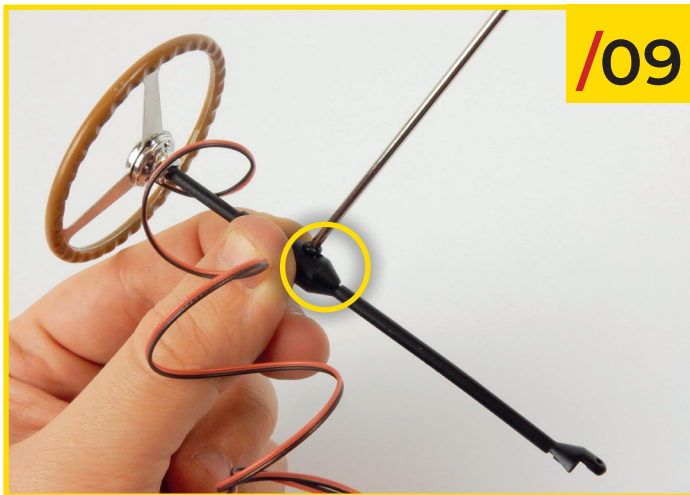
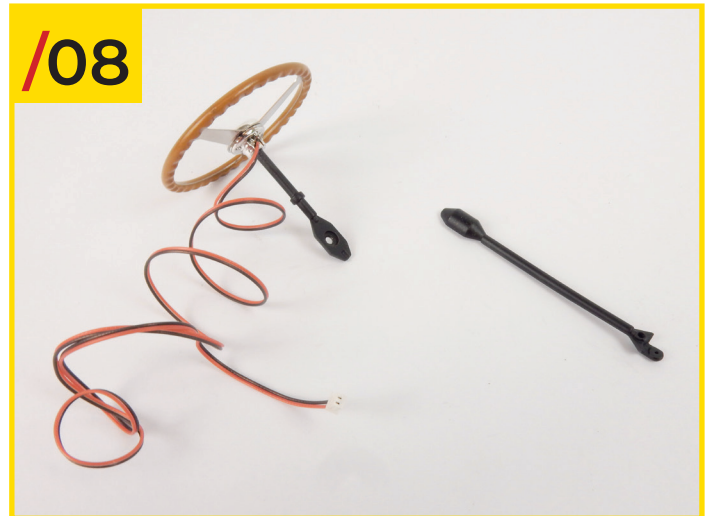

01/09 Join the two pieces by aligning their holes and fasten them together with a type C screw.



**STAGE 01 IS COMPLETE**  
The front bonnet and steering wheel of your 1:8 scale model of the Ferrari 250 GTO are ready.

## Stage 02: The Instrument Panel And The Left Door

In this stage you will begin work on the dashboard and left door.



### STAGE 02 PARTS LIST

Name	Name
1 Dashboard	6 Handle
2 Frame	7 Interior door frame
3 Dials	
4 Lenses	3 type B screws
5 Door	4 type C screws

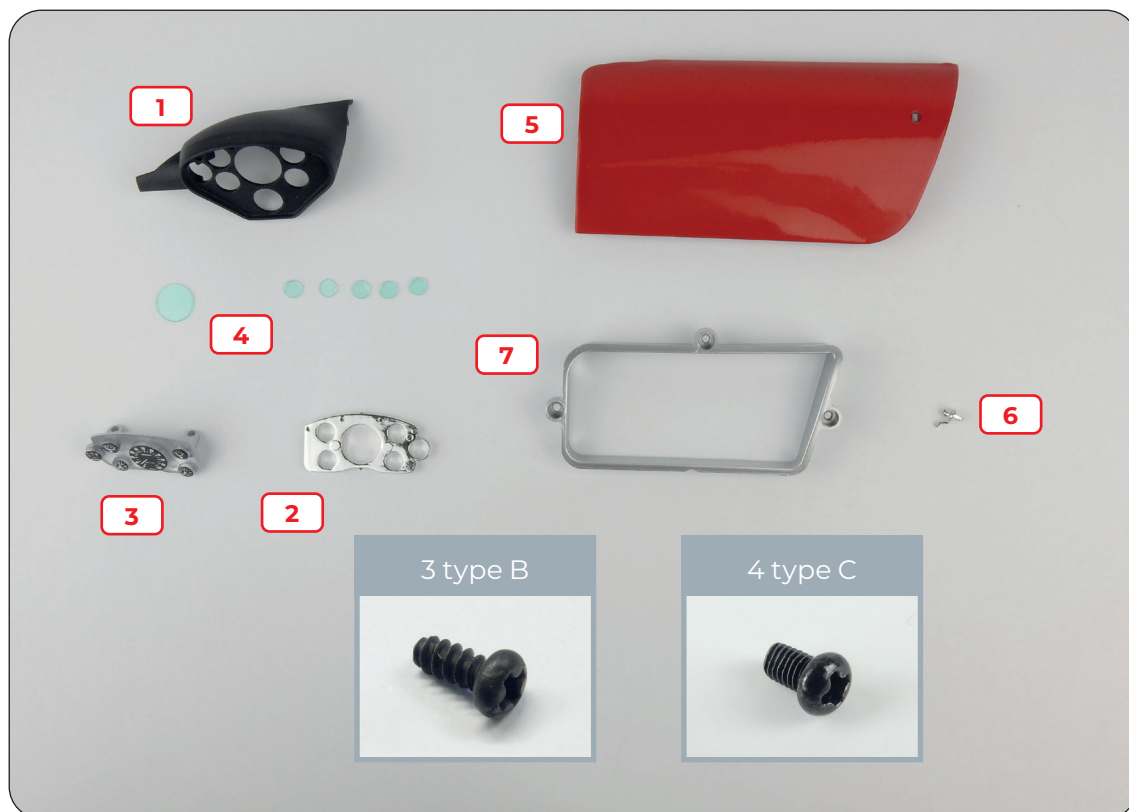

## Stage 02: The Instrument Panel And The Left Door



**/01**

02/01 Position the frame on the inside of the dashboard as shown in the photo.

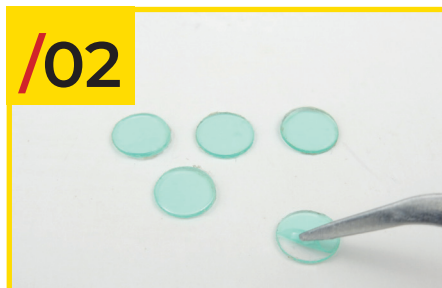

**/02**

02/02 Place the five small lenses on your work surface and, with the help of tweezers, remove the protective film on both sides of them.

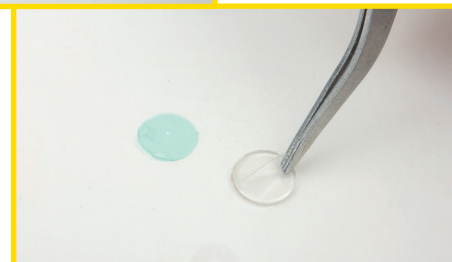

**/03**

02/03 Now insert the five small lenses into their recesses on the inside of the frame, as shown in the photo. You can clean the five lenses with a cloth before inserting them.

02/04 Insert the five lenses so that they sit flat and do not protrude from the edge of the holes.



**/04**



## Stage 02: The Instrument Panel And The Left Door

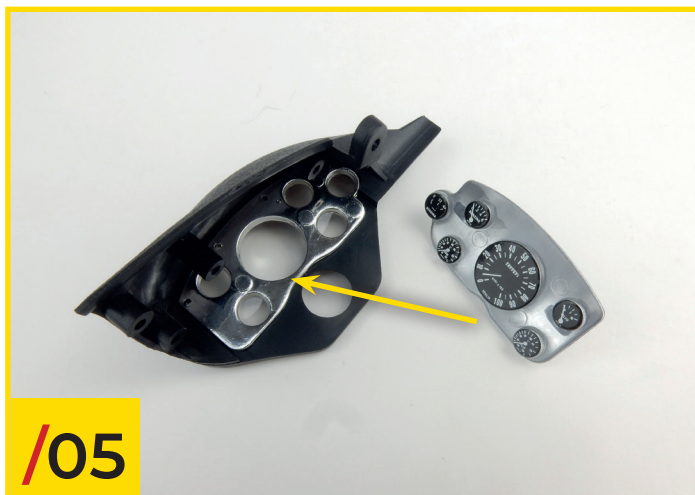

02/05 Insert the dials into the assembly.

02/06 Fasten the parts together with two type B screws.



02/07 Now take the large lens and remove the films, as you did with the small ones in step 02. Insert the large lens into its recess on the outside of the frame.

02/08 Place the door frame on the inside of the door.

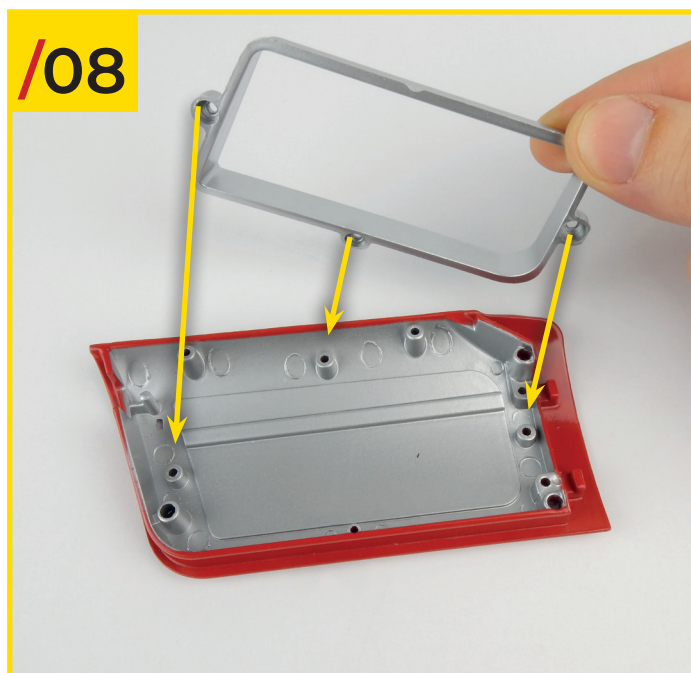

## Stage 02: The Instrument Panel And The Left Door

/09



02/09 Fasten the pieces together with three type C screws.

02/10 Join the handle to the door, paying attention to the orientation of the pieces shown in the image.

/10



STAGE 02 IS COMPLETE  
Here are the left door and instrument panel at the end of this assembly stage.



## Stage 03: Dashboard, Floor And Gearbox Parts

In this stage you will finish the dashboard and start working on the floor and gearbox of your model.



### STAGE 03 PARTS LIST

Name	Name
1 Dashboard	7 Rail B
2 Gearbox (left half)	8 Adjustment lever
3 Gear lever	
4 Floor (front half)	3 type B screws
5 Floor plate	2 type C screws
6 Rail A	

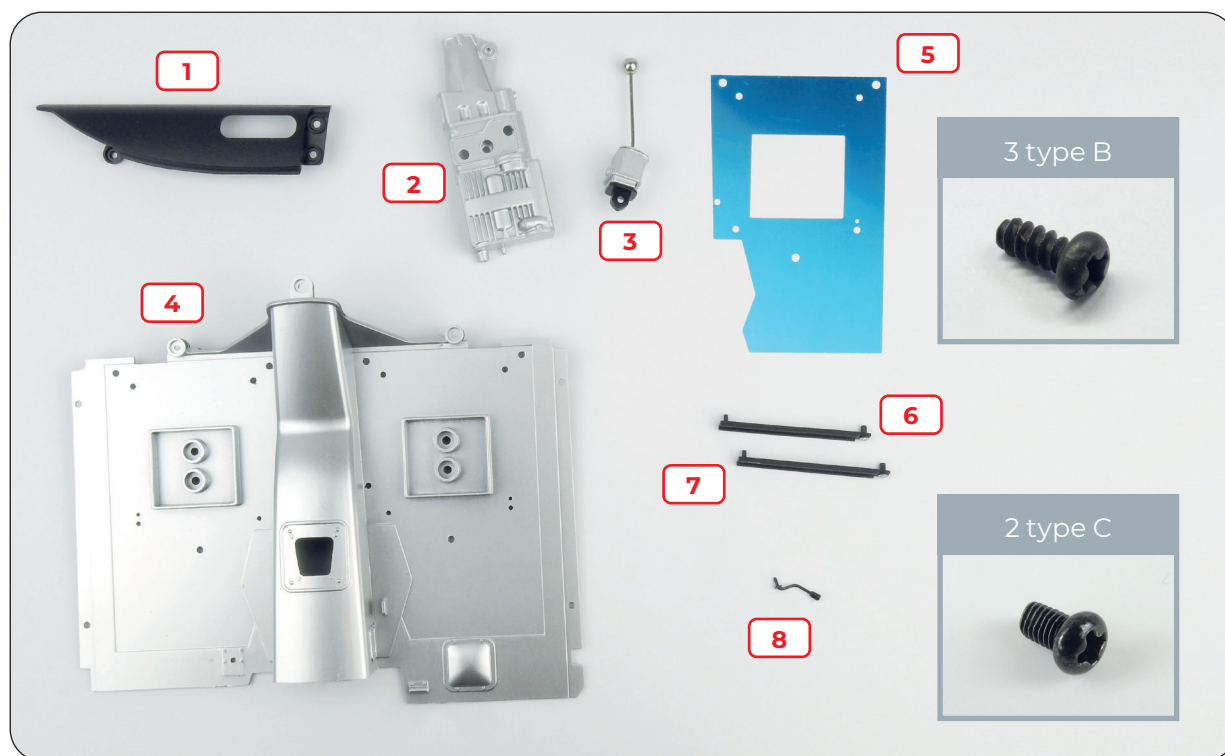

## Stage 03: Dashboard, Floor And Gearbox Parts



03/01 Retrieve the instrument panel you assembled in stage 02 and join it to the dashboard received in this stage. Fix the pieces together with two type B screws.

03/02 Join the gear lever to the left half of the gearbox, orientating the pieces as shown in the photo. Tighten a type C screw in the hole shown to secure them together.

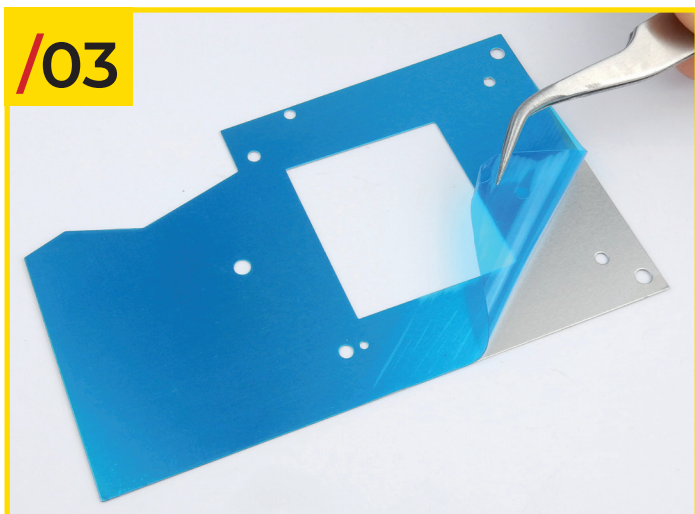
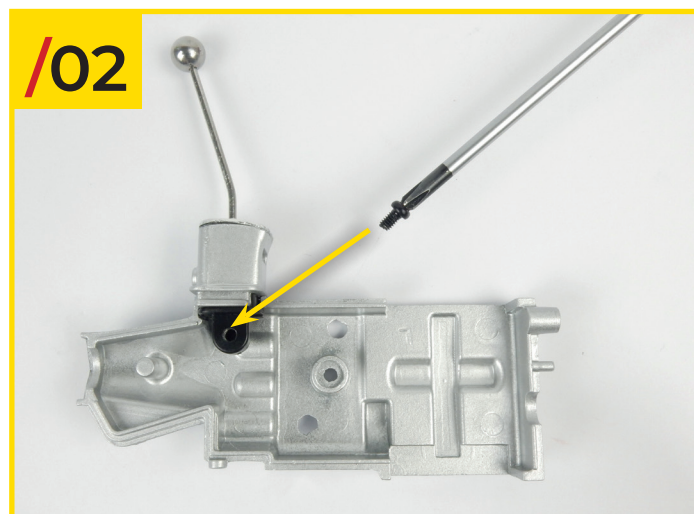

03/03 Using a pair of tweezers, remove the protective film from the upper side of the floor plate. Peel the backing from the adhesive sticker on the under side.

03/04 Stick the plate into the recess in the floor.

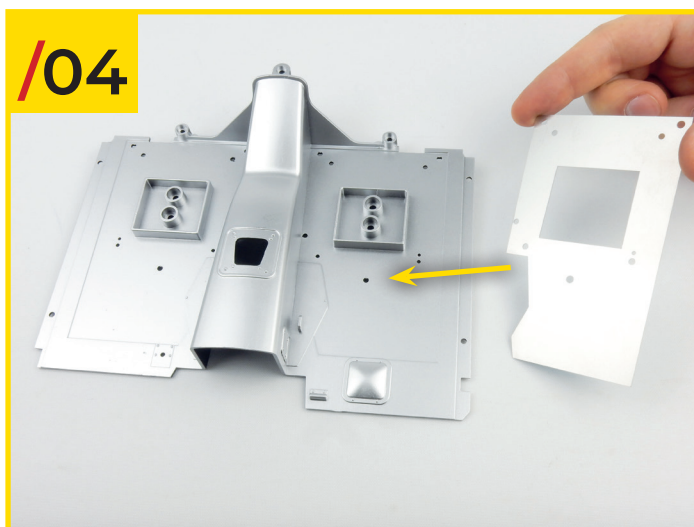
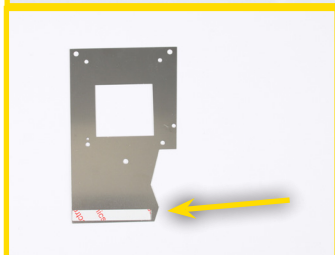

## Stage 03: Dashboard, Floor And Gearbox Parts

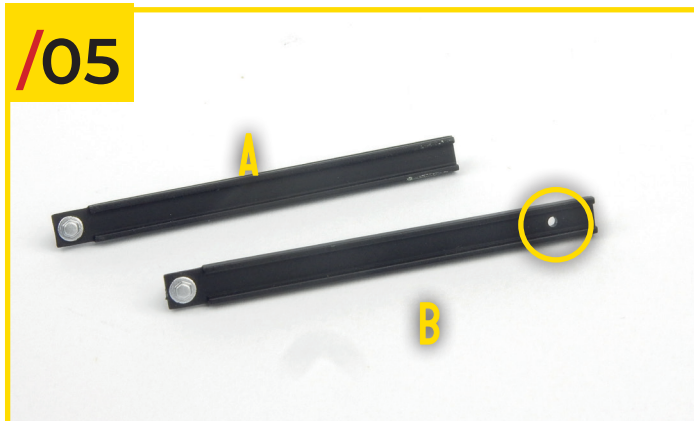

03/05 Unlike rail A, rail B has a hole at one end (yellow circle).



/06

03/06 Insert the pin at the base of the adjustment lever into the hole indicated by the arrow on rail B.

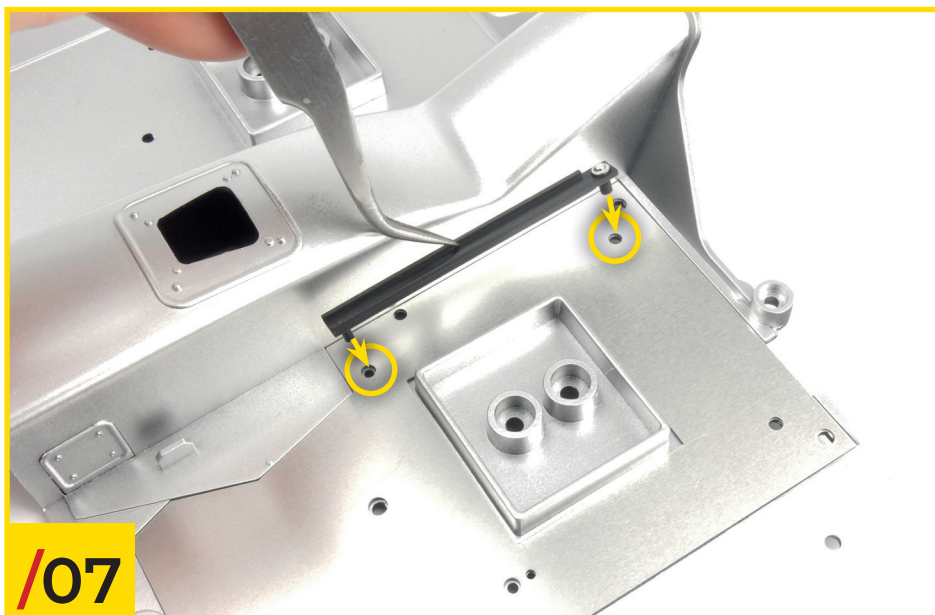

/07

03/07 Join rail A to the floor plate. Look carefully at the photo to orientate the pieces correctly.

03/08 Also attach rail B, equipped with the adjustment lever, to the floor plate.



/08

## Stage 03: Dashboard, Floor And Gearbox Parts

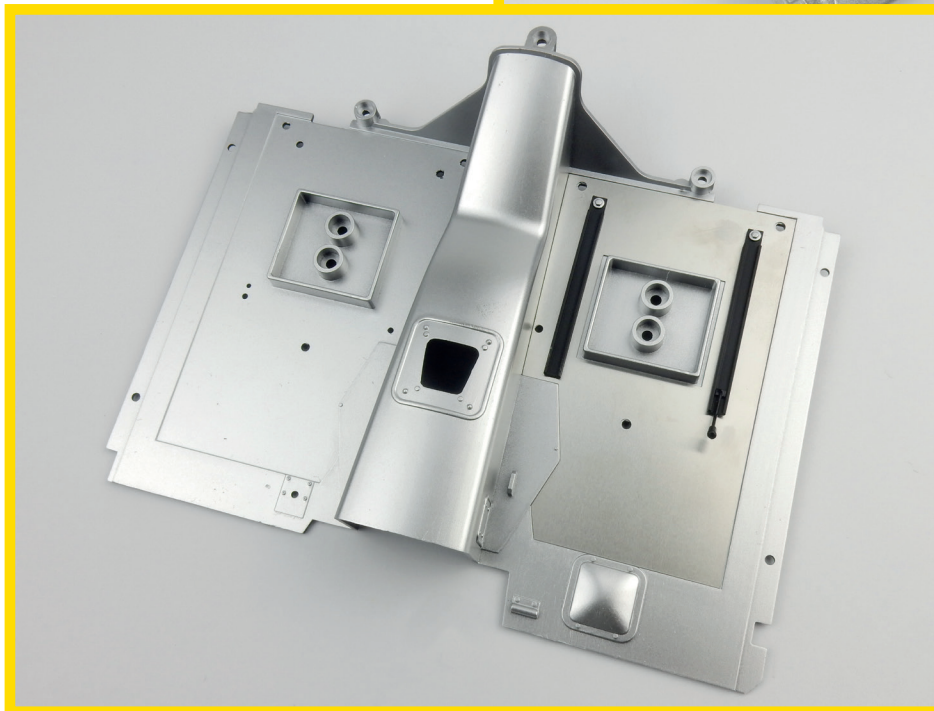
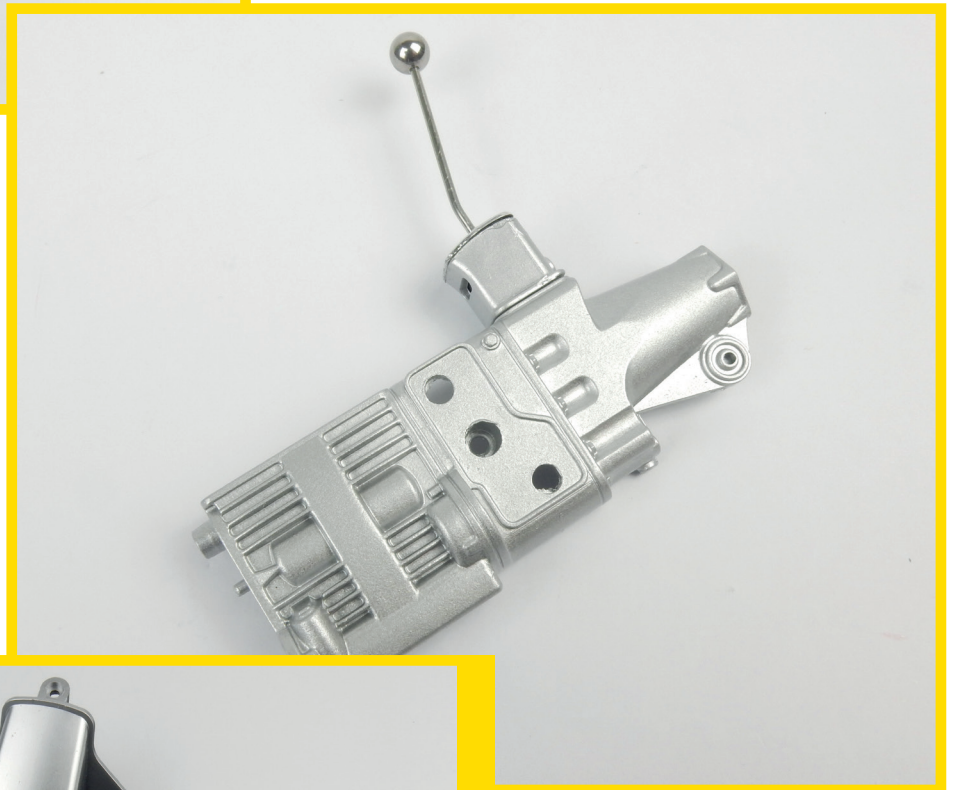

STAGE 03 IS COMPLETE  
Here are the different  
components assembled in  
this stage.

## Stage 04: Floor, Gearbox And Clutch Bell

In this stage you will continue working on the floor and the gearbox of your model and you will also assemble the clutch bell.



### STAGE 04 PARTS LIST

Name	Name
1 Floor plate	7 Clutch bell
2 Rail A	8 Seal plate
3 Rail B	9 Bell panel
4 Adjustment lever	
5 Gearbox (right half)	4 type C screws
6 Side panel	

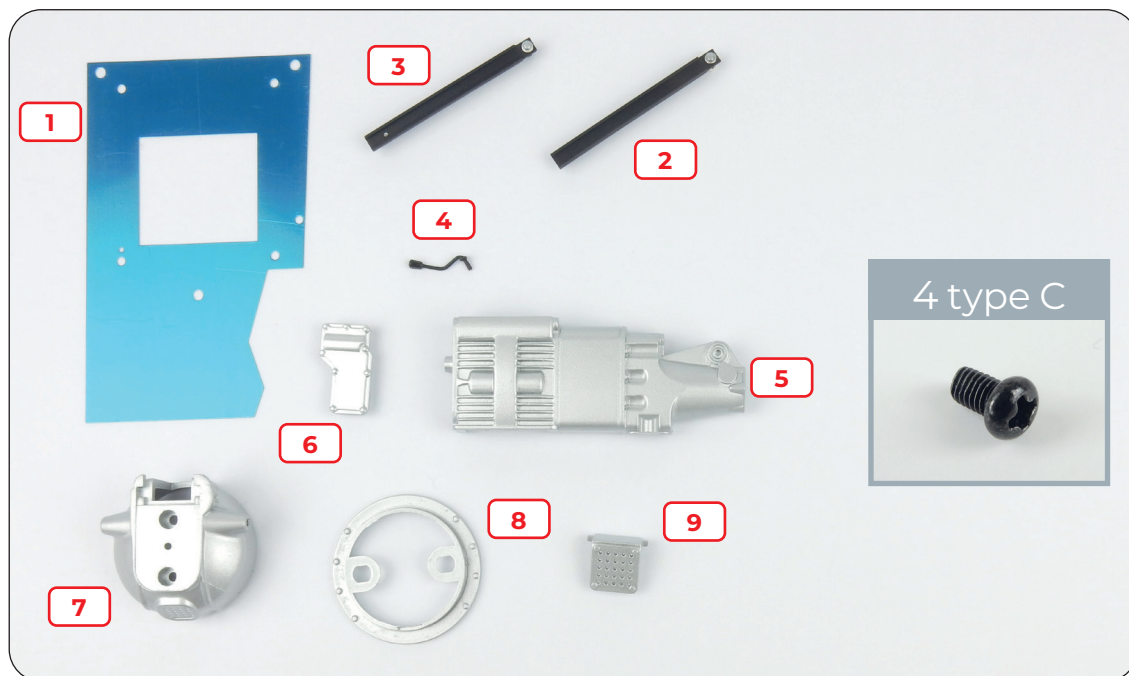

## Stage 04: Floor, Gearbox And Clutch Bell

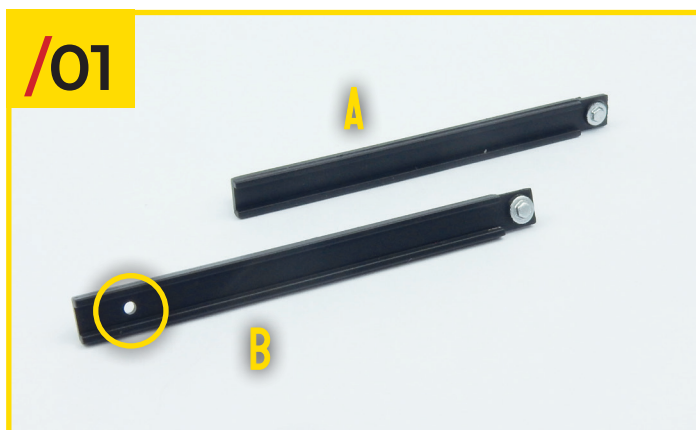

04/01 Unlike rail A, rail B has a hole at one end (yellow circle).



04/02 Insert the pin at the base of the adjustment lever into the hole in rail B.

04/03 As you did in stage 03, remove the protective foil from the upper side of the floor plate, peel the backing from the adhesive sticker on the underside and stick it into the recess on the floor.

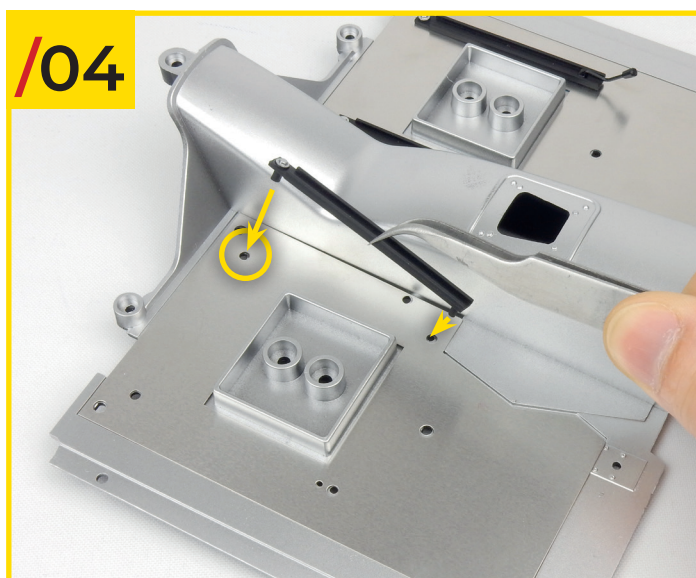
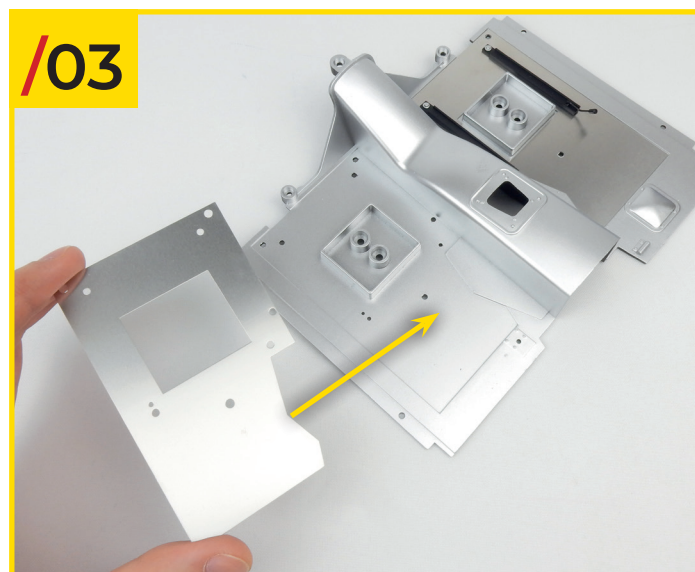

04/04 Join rail A to the floor plate, aligning the pieces as shown.

04/05 Also attach rail B, fitted with the adjustment lever, to the floor plate.

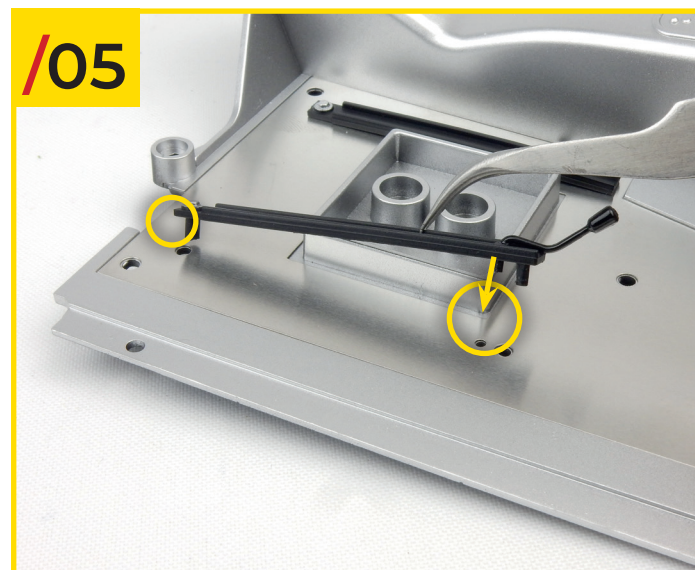



## Stage 04: Floor, Gearbox And Clutch Bell

**/06**

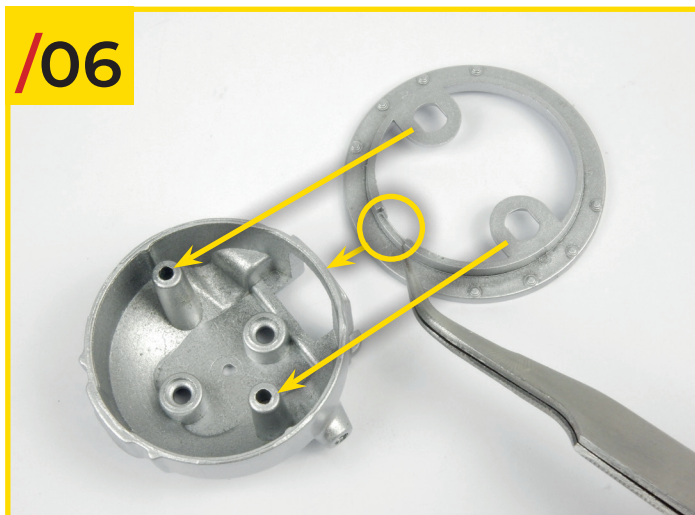

04/06 Join the seal plate to the clutch bell by aligning the pieces as shown in the photo.

04/07 Turn the bell over and insert the tab on the bell panel (highlighted by the circle in the photo) into the opening of the bell, and the notch on the seal plate.

**/07**



04/08 The photo shows the components correctly assembled.

**/08**

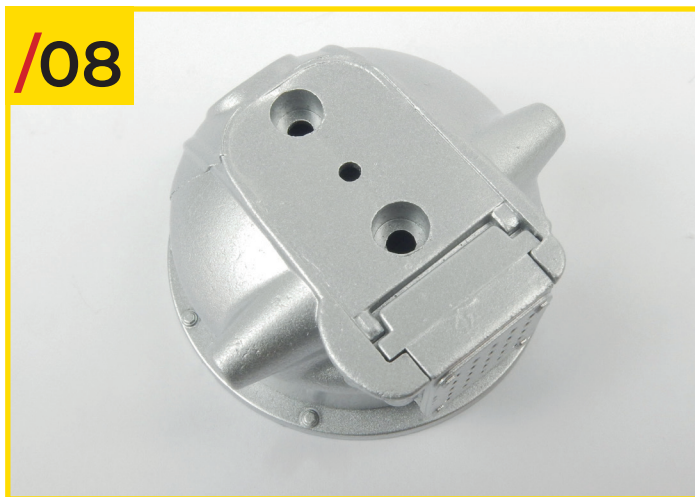

04/09 Retrieve the left half of the gearbox, which you worked on in stage 03, and join it to its right half. Fix the two halves together with a type C screw, as shown in the photo.

**/09**

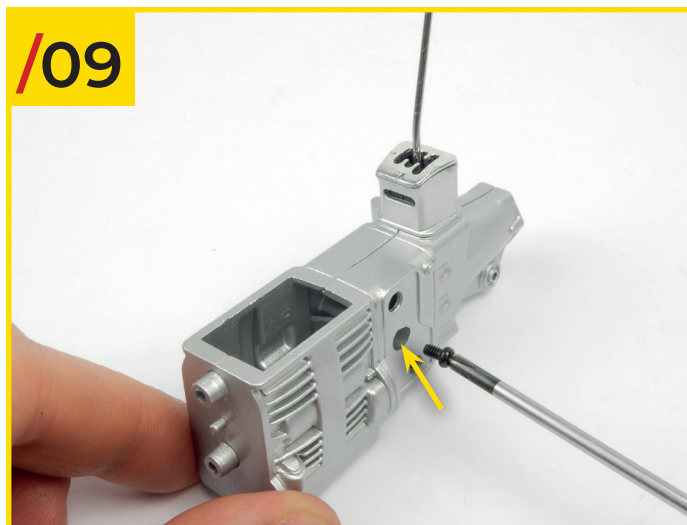

## Stage 04: Floor, Gearbox And Clutch Bell

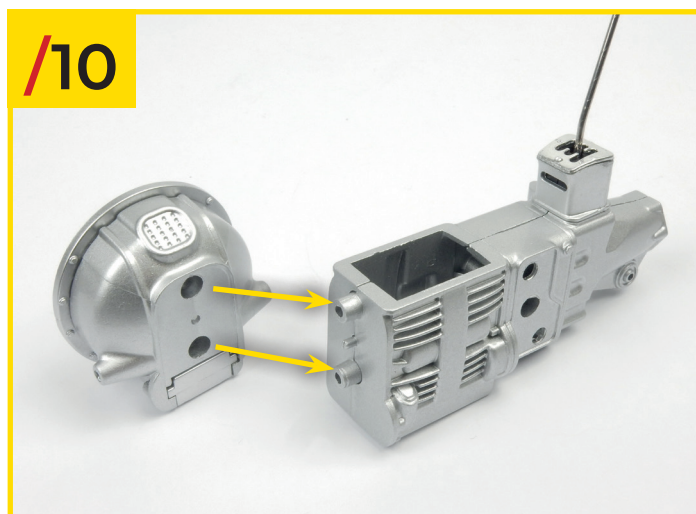

04/10 Join the clutch bell to the gearbox as shown.

04/11 Fix the pieces together by tightening two type C screws in the holes indicated.

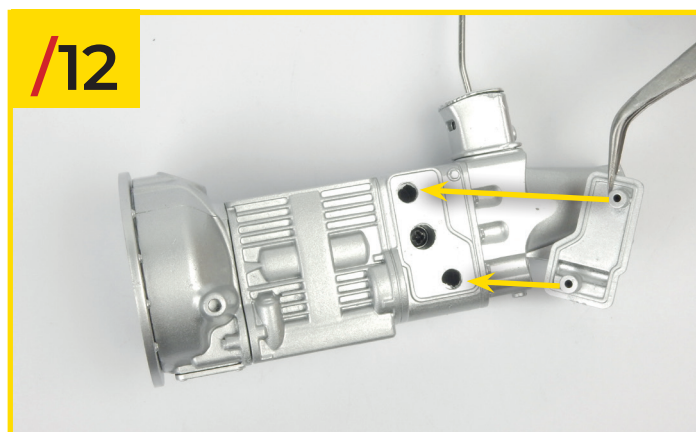
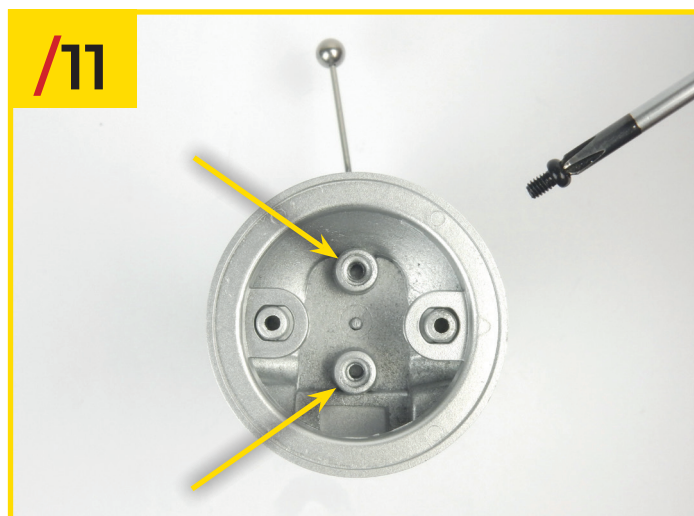

04/12 Finally, place the side panel into its recess on the outer side of the left half of the gearbox. The pieces fit together with a slight pressure.



STAGE 04 IS COMPLETE  
Here is the result of this assembly stage.

## Stage 05: Rear Floor Pan And Details

In this stage you will continue working on the floor of your model. You will use the seat, belt and belt hooks in the next stage.



### STAGE 05 PARTS LIST

Name	Name	Name
1 Floor (rear half)	7 Handbrake base	13 Seat belt
2 Oil filling pipe	8 Handbrake lever	14 Belt hooks*
3 Hose	9 Seat	15 Upper panel
4 Belt hooks*	10 Support bar B	16 Bottom panel
5 Rear supports	11 Stopper "L"	5 type B screws
6 Support bars A	12 Stopper "R"	3 type F screws

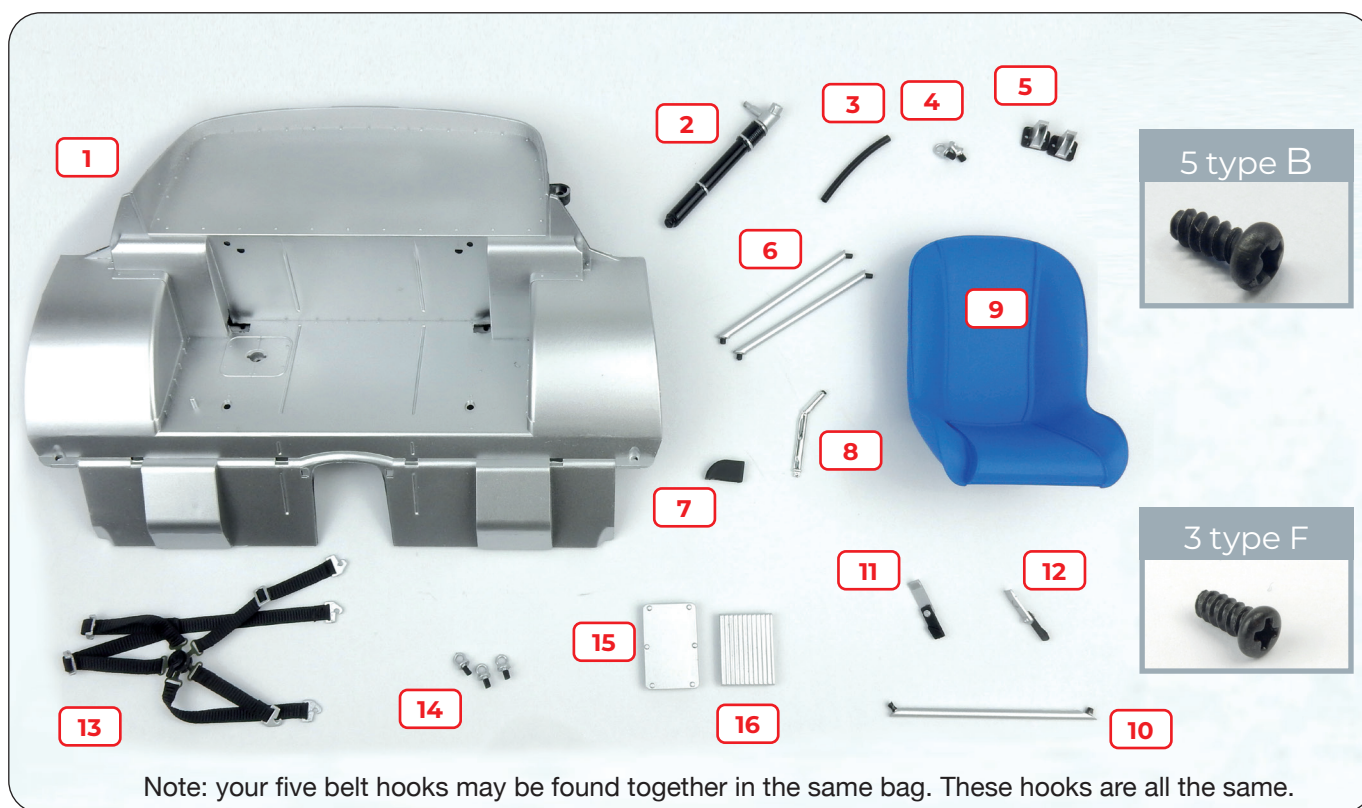

## Stage 05: Rear Floor Pan And Details

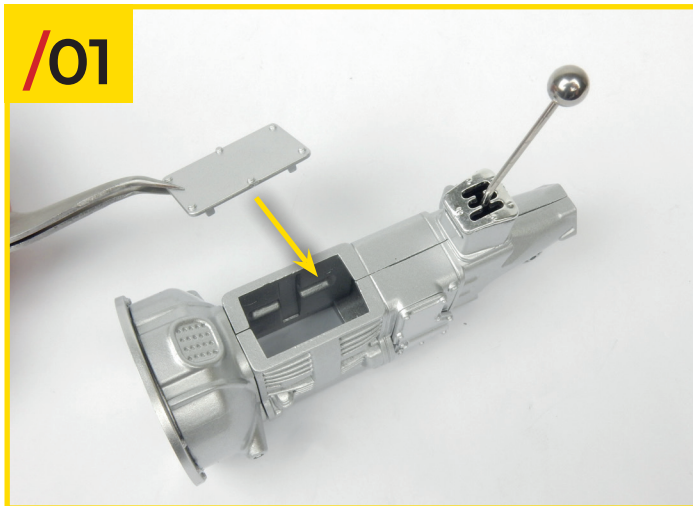

05/01 Install the upper panel on the gearbox.

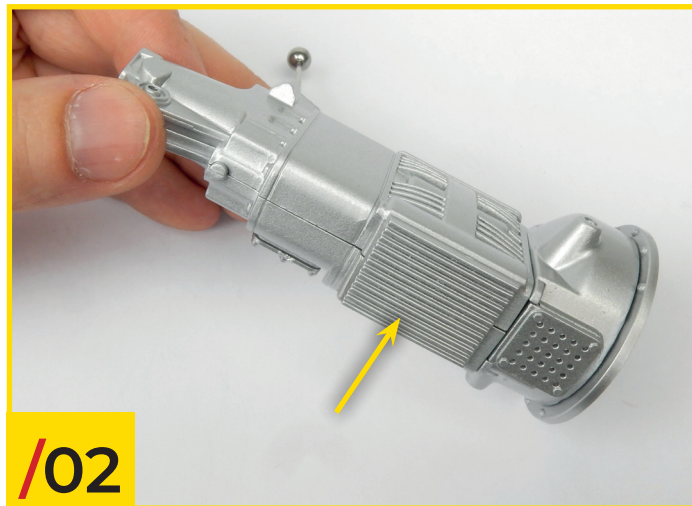

05/02 In the same way, join the bottom panel to the gearbox.

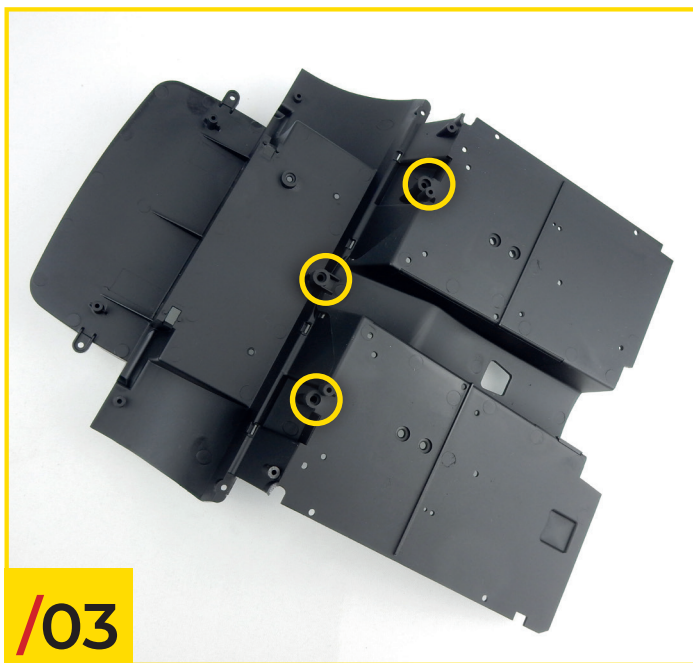

05/03 Join the two halves of the floor by aligning them as shown. Secure the pieces together by tightening three type B screws in the holes indicated.

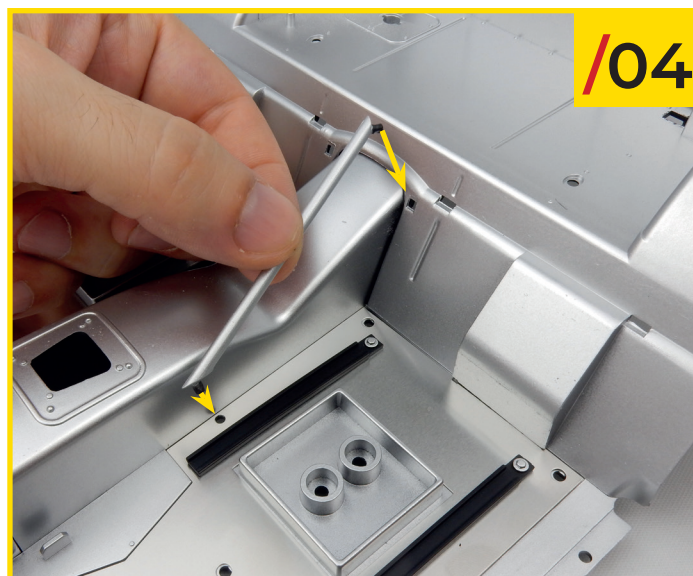

05/04 Join support bar B to the floor pan, orientating the pieces as shown in the photo. Check the longer angled end is in the lower position. You may need to flex the support bar slightly to fit.

## Stage 05: Rear Floor Pan And Details

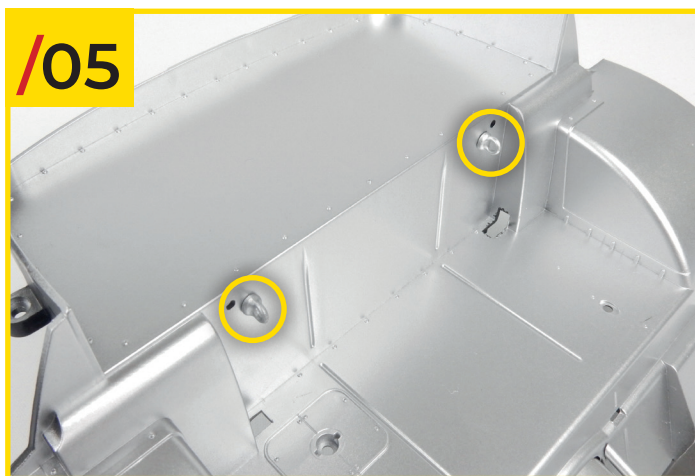

05/05 Insert two of the belt hooks into the holes shown in the photo, on the rear half of the floor. The pieces can fit together in only one position.

05/06 Turn the floor upside down and insert both rear supports into their positions shown.

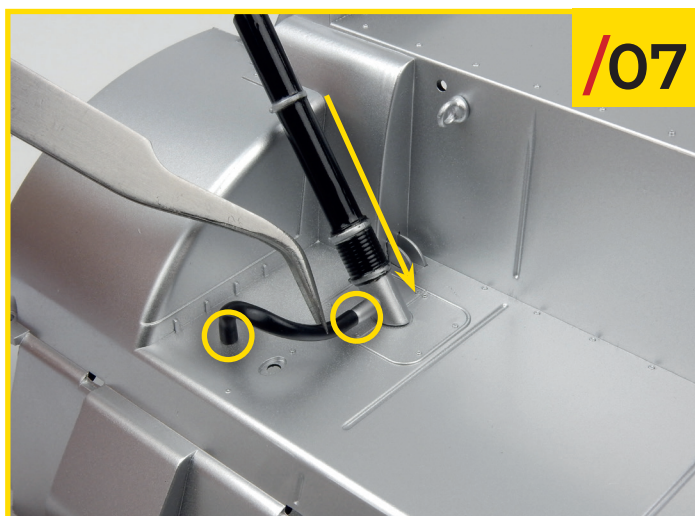

05/07 Join the oil filling pipe to the rear floor half, in the location you can see from the photo. Fit the ends of the hose onto the pins indicated.

05/08 Turn the floor upside down and fix the pipe with a type B screw, as shown.

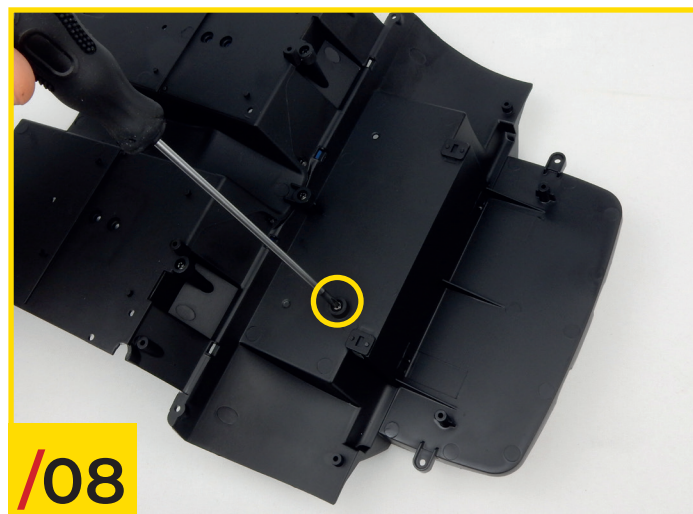

## Stage 05: Rear Floor Pan And Details

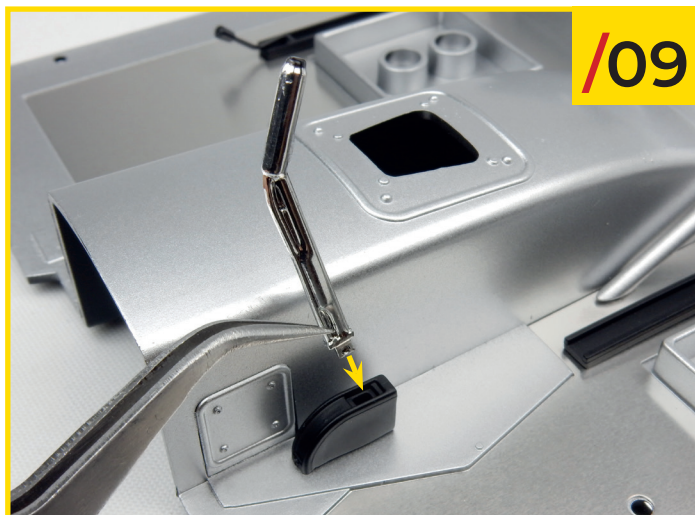

05/09 Install the handbrake base on its seat at the front of the floor; once done, join the lever to the base. Observe the photo to orientate the parts correctly.

05/10 Finally, install the two support bars A at the rear of the floor. Use the photo to identify the holes where you will have to insert the pins of the bars. Slide the right-hand support bar under the hose. Note: the ends of the support bars are different. The longer angled end must be in the lower position (10a). You may find it easier to insert the bottom in first, then the top.

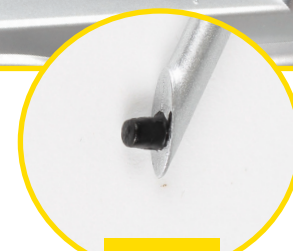
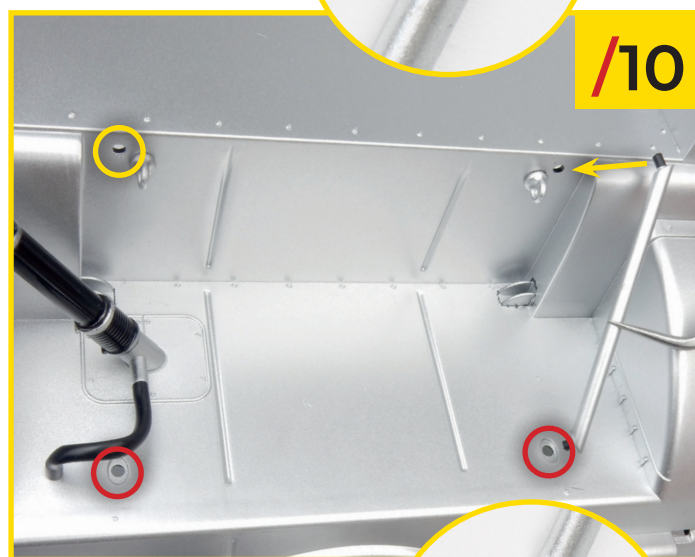

/10a

STAGE 05 IS COMPLETE  
Here is the result of this assembly session. You will install the seat and other pieces in the next stage.

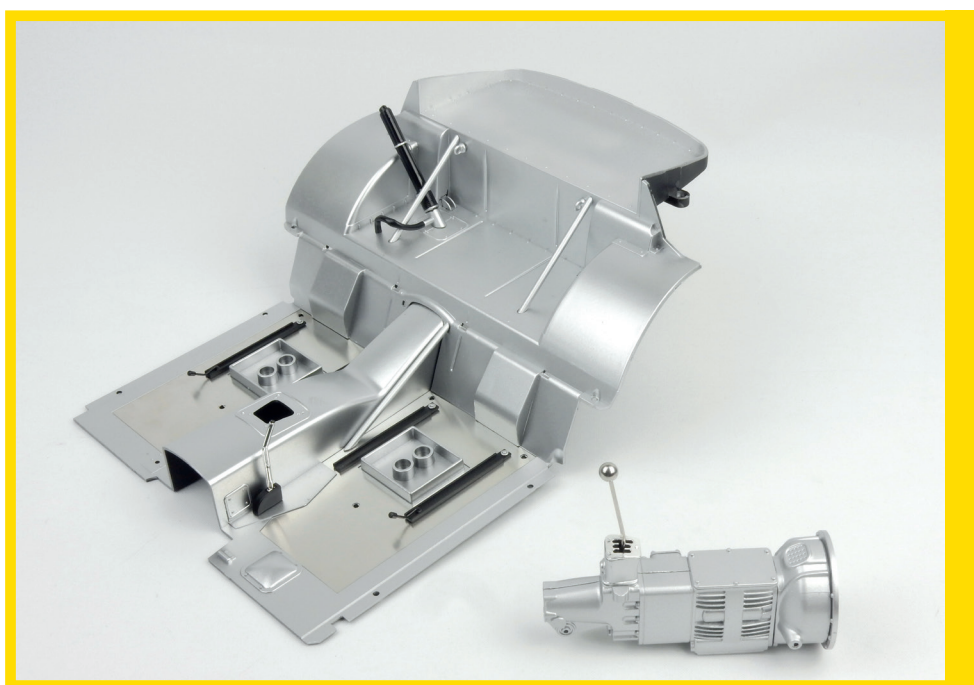

## Stage 06: Seats And Belts

In this stage you will join both seats and their belts to the floor. You will also continue working on the gearbox, adding two detail elements to it.



### STAGE 06 PARTS LIST

Name	Name
1 Seat	7 Front cover
2 Support bar	8 Joint
3 Stopper "L"	3 type F screws
4 Stopper "R"	
5 Seat belt	
6 Belt hooks	



## Stage 06: Seats And Belts



06/01 Insert the joint into the front cover, matching the interlocking elements of the two pieces.

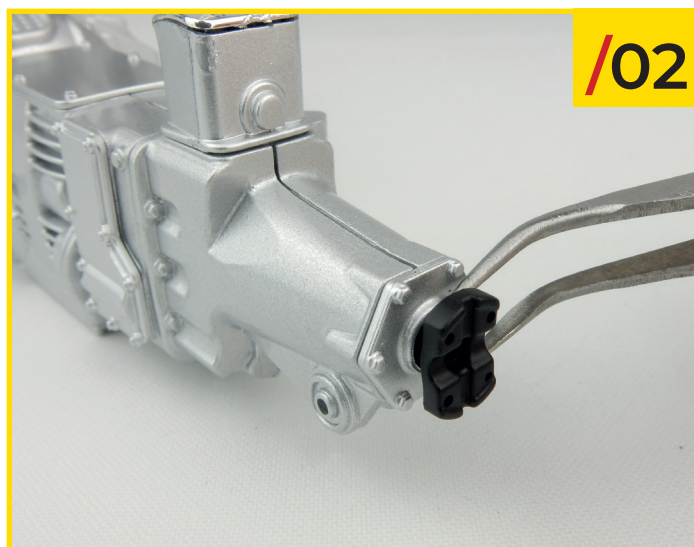

06/02 Join the unit you have just assembled to the gearbox you have worked on in previous stages.



06/03 As you did in stage 05, join the support bar to the floor by orientating the pieces as shown in the photo. The longer angled end must again be in the lower position.

06/04 Insert three seat belt hooks received in stage 05 into their respective slots on the front floor. Note: the hooks have a D-shaped pin and the flat part of the pin should face towards the rear of your model.

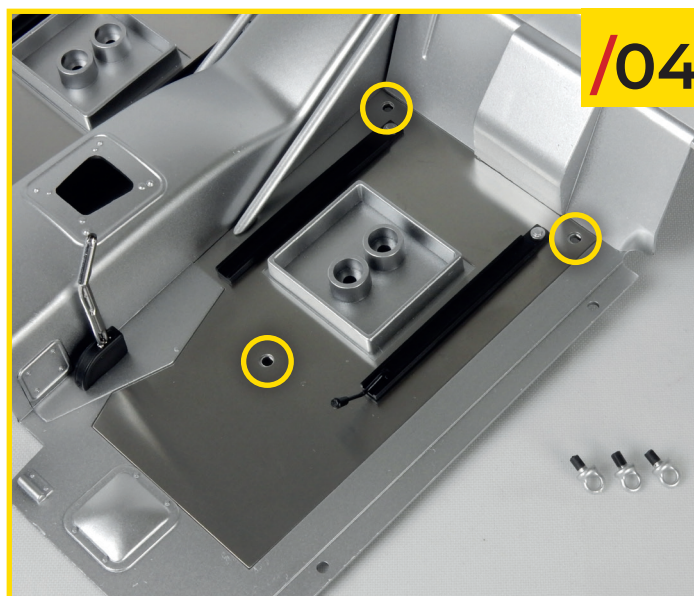



## Stage 06: Seats And Belts

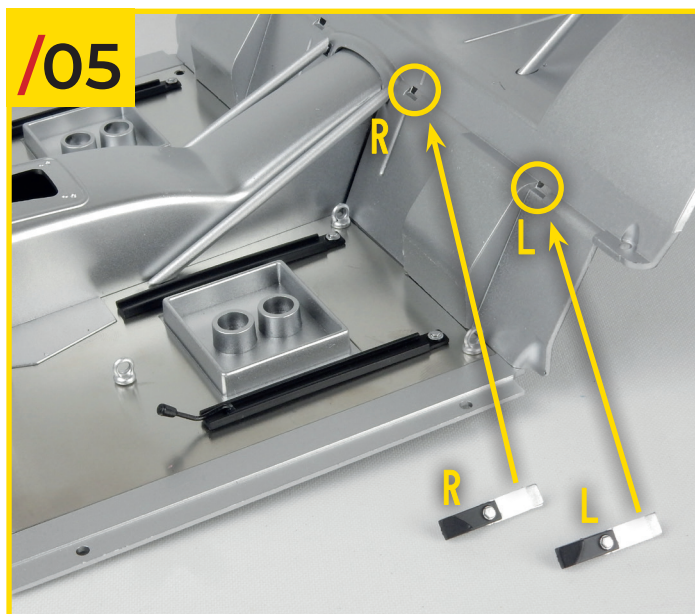

06/05 Insert the "L" and "R" stoppers received in stage 05 into the respective holes in the floor.

06/06 Join the seat belt from stage 05 to the hook identified in the photo. Use the photo to orientate the belt correctly and attach it in the direction shown in the round detail picture. Do not join the belt to the other hooks.

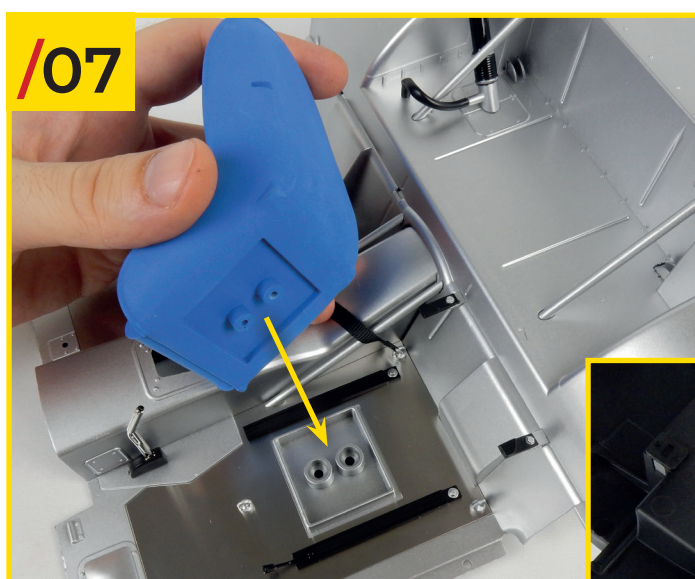

06/07 Rest the seat belt on the other side of the floor and install the seat you received in stage 05. Turn the floor upside down and attach the seat using two of the type F screws you received in stage 05.

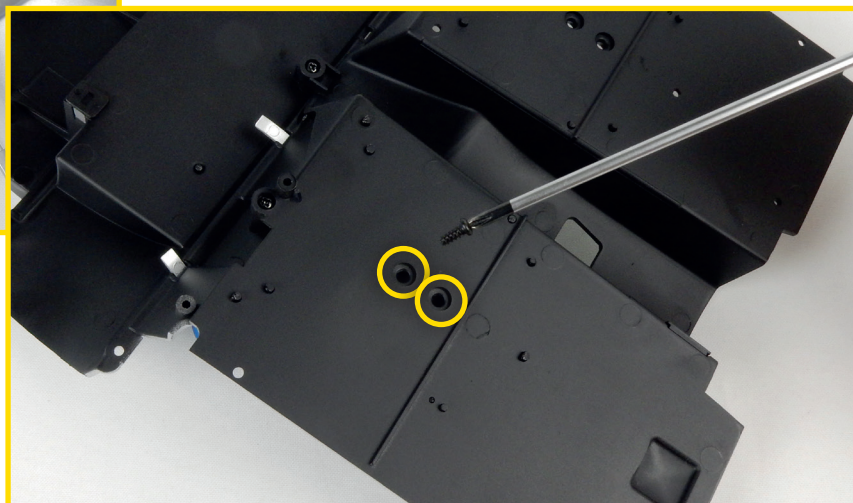

## Stage 06: Seats And Belts

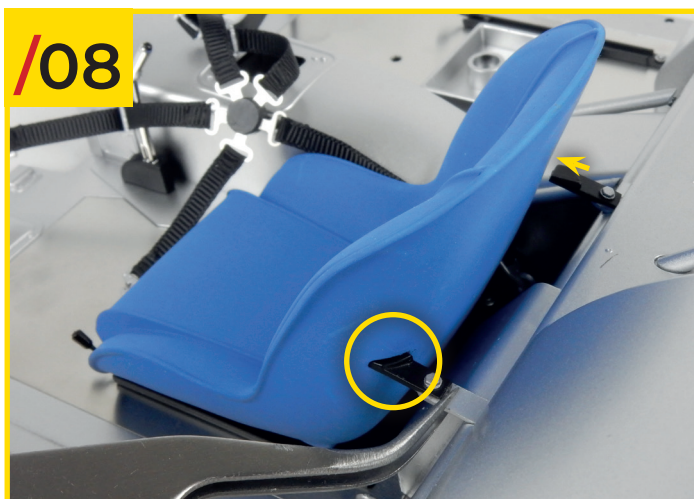

06/08 Insert the stoppers into the rear side of the seat.

06/09 You can now join the seat belt to the other three hooks, identified in the photo.



06/10 Repeat steps 04-09 to install the hooks, stoppers, seat belt and seat you received in this stage.



/10

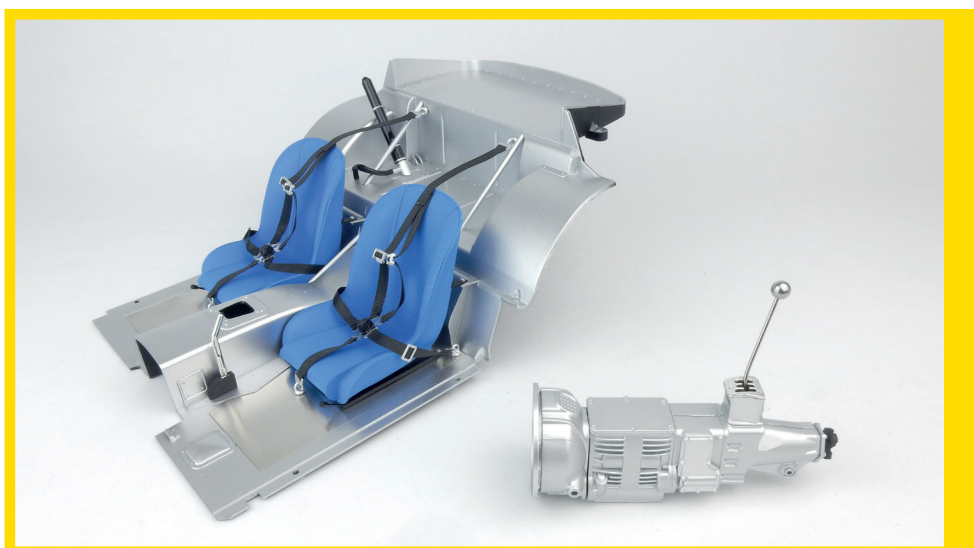

**STAGE 06 IS COMPLETE**  
This is what the floor and gearbox look like at the end of this assembly stage.