

OPTIMUS PRIME



Pack 10

BUILD INSTRUCTIONS

ASSEMBLING THE HIP WHEELS

ATTACHING THE WHEELS TO THE HIPS

ASSEMBLING THE UPPER LEFT LEG

ASSEMBLING THE UPPER RIGHT LEG

ASSEMBLING THE HIPS AND ATTACHING THEM TO THE LEGS

AGORA
MODELS®

Advice from the experts

 **Please keep ALL unused screws as they may be required in a later stage.**

Please make sure you don't mix up the screws. They look quite similar, but the threads do vary slightly. Using the wrong screws may damage the parts.

When securing parts together using multiple screws, fit each screw loosely to ensure all the parts are correctly aligned before gently tightening them firmly, but not overtight, in the order in which you placed them.

The screwdriver can be magnetized by stroking it with a magnet (fridge magnet, etc.) enabling it to hold the screws and make assembly easier.

If a screw is tight going into a metal part, do not force it as you may shear the head off. Remove it and put a tiny smear of Vaseline, soap or light oil on the thread. That will lubricate it and make it easier to drive home.

Some parts will require a little glue for assembly. Please apply glue sparingly and use a cocktail stick so that you don't use too much nor apply the glue too heavily. We recommend superglue gel or Extra Thin Liquid modeling glue. Where possible, parts should be test-fitted in place before gluing.



Look out for the glue symbol and apply glue to the red area indicated in the picture.

During the course of this build, you will receive many pieces that you will assemble immediately – following the instructions in the corresponding stage – and other pieces that you should store in the tray supplied, for use in future assembly stages.

Always protect the paint finish on components by placing a cutting mat, sheet of white paper or soft cloth on your work surface.

Left and Right! When building your Optimus Prime, the left or right hand side refers to each side as viewed by Optimus Prime. Optimus Prime's left arm is on the viewer's right.



WARNING: Some parts are assembled using magnets. These magnets can cause serious injury if they are swallowed. Keep away from children. If you suspect a magnet has been swallowed, seek medical help straight away.

Pack 10 Parts

TRAY 1: SCREWS

TR-10-57 x12

TR-10-73 x2

TR-10-69

TR-10-70

PM
3x6 mm x4

M
3x10 mm x8

M
3x6 mm x16

PB
2.6x6 mm x7

nut 3 x4

M
3x8 mm x22

PWM
2x6 mm x11

PWB
2.3x6 mm x3

PWB
2.6x6 mm x9

PB
2.3x8 mm x9

PB
2.6x8 mm x58

PB
2.3x6 mm x43

Pack 10 Parts

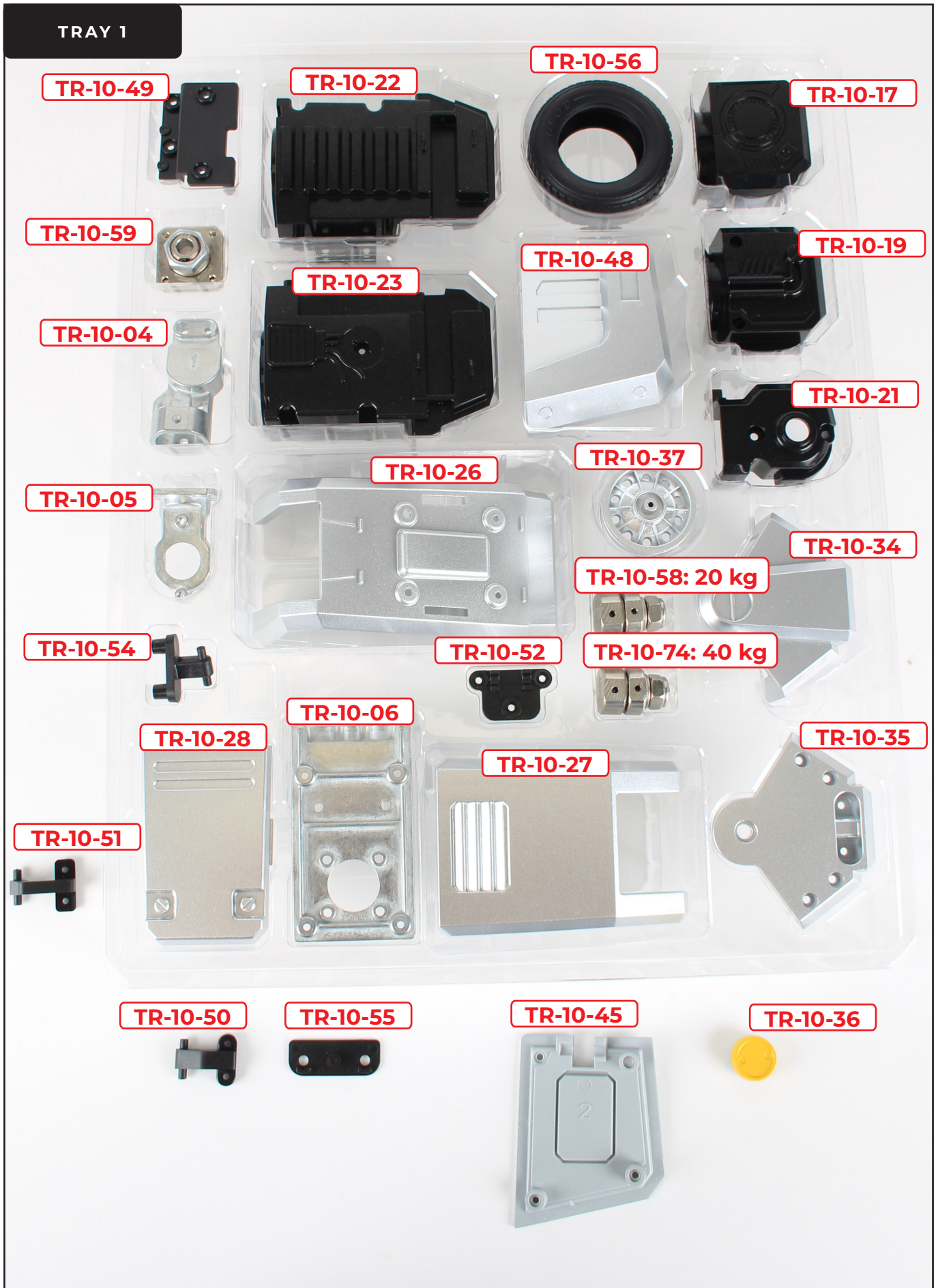

Pack 10 Parts

TRAY 2

TR-10-49

TR-10-25

TR-10-56

TR-10-16

TR-10-59

TR-10-24

TR-10-43

TR-10-18

TR-10-08

TR-10-20

TR-10-05

TR-10-26

TR-10-37

TR-10-34

TR-10-53

TR-10-58: 20 kg

TR-10-52

TR-10-74: 40 kg

TR-10-06

TR-10-28

TR-10-27

TR-10-35

TR-10-51

TR-10-50

TR-10-44

TR-10-36

TR-10-55

Pack 10 Parts

TRAY 3

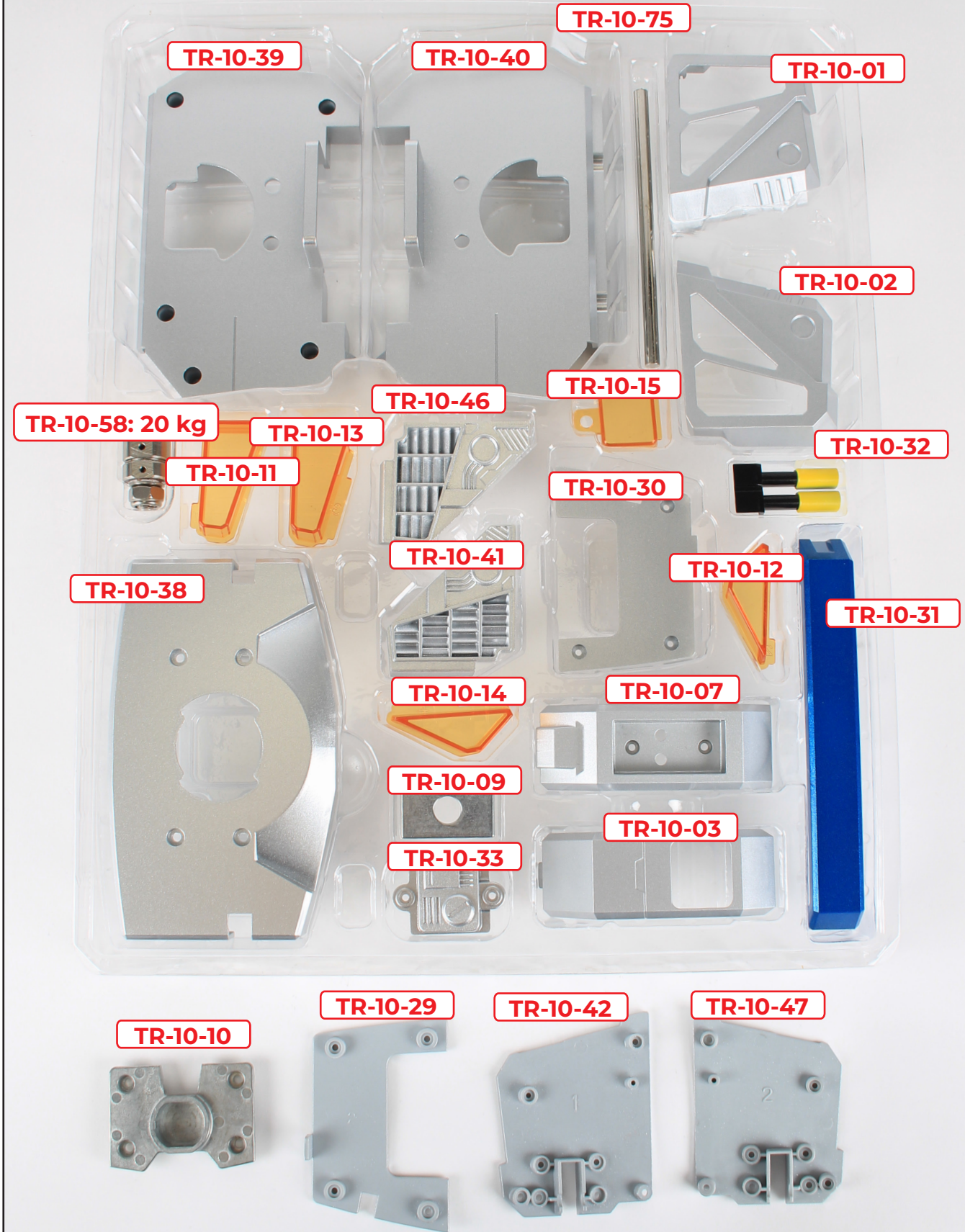

Assembling the Hip Wheels

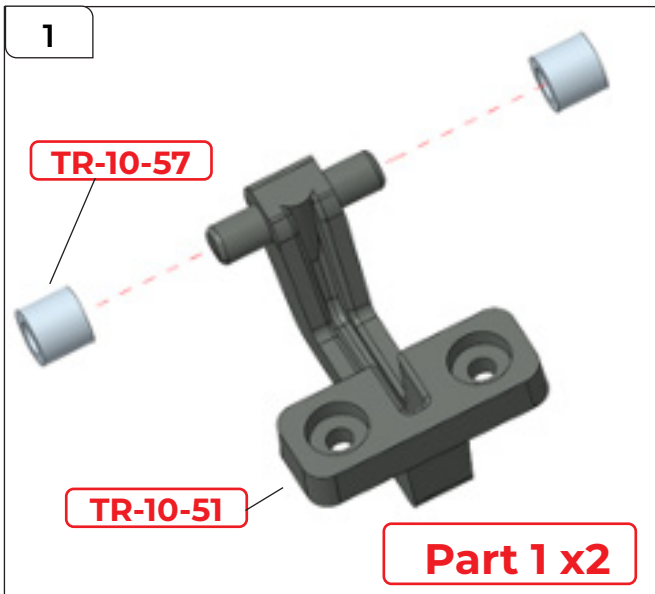

STEP 1

Push 2x TR-10-57 onto each post on TR-10-51. Repeat with another part TR-10-51 to make 2x Part 1 assemblies.

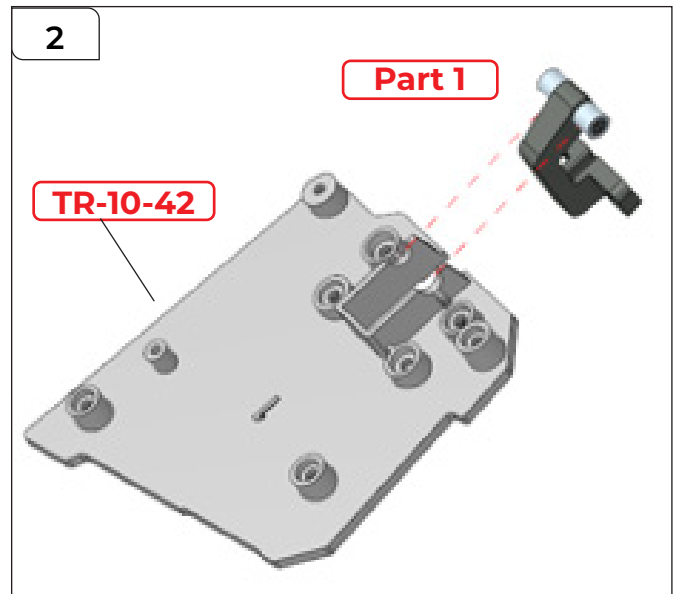

STEP 2

Attach 1x Part 1 to TR-10-42

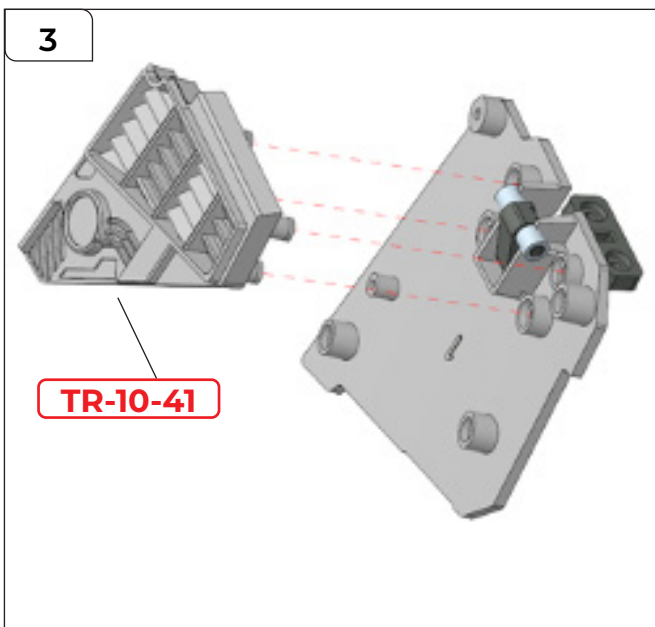

STEP 3

Place TR-10-41 onto TR-10-42 – on top of Part 1.

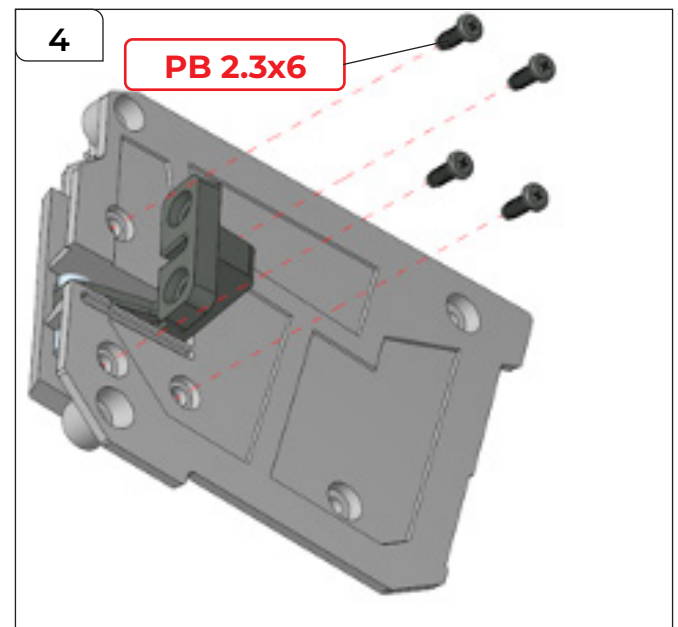

STEP 4

Secure parts from the reverse side using 4x PB 2.3x6 mm screws.

Assembling the Hip Wheels

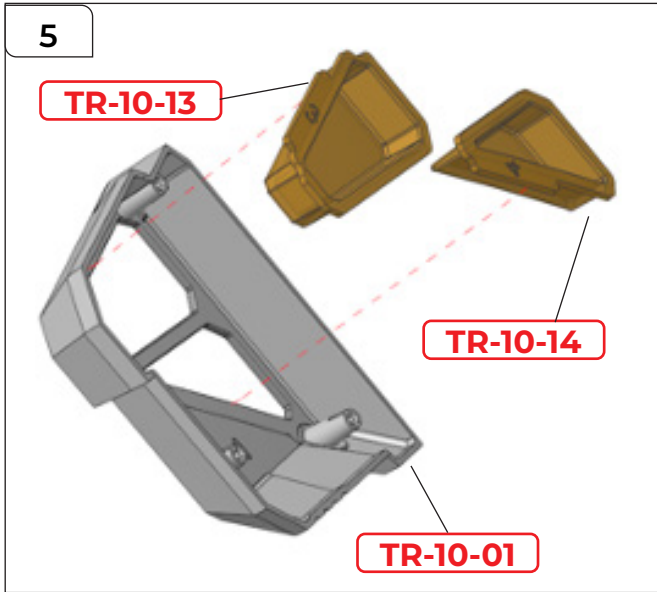

STEP 5

Place TR-10-13 and TR-10-14 onto TR-10-01.

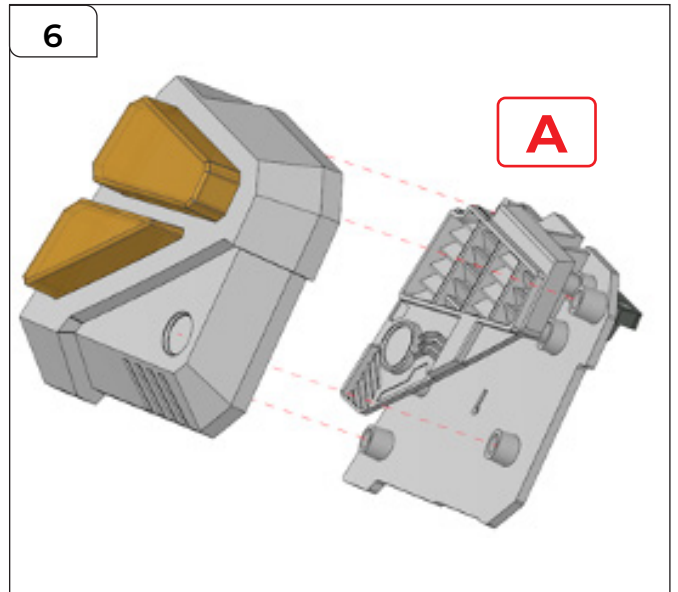

STEP 6

Attach the assembly from Step 5 to the assembly A, from Step 4.

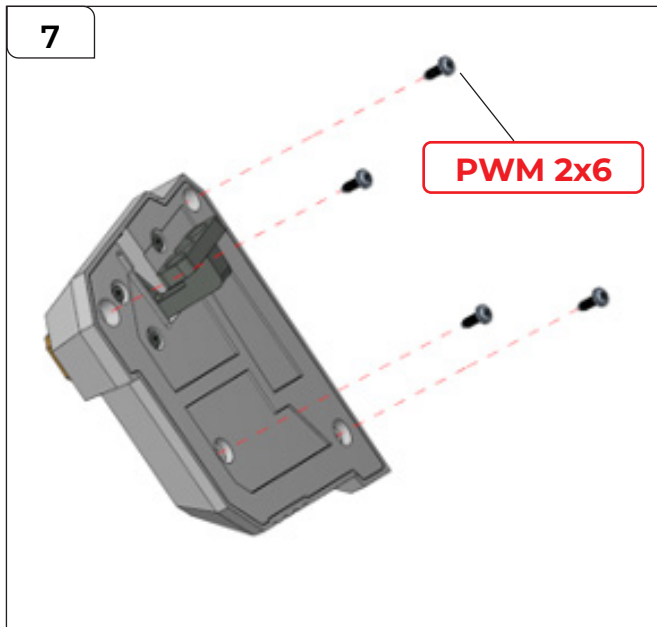

STEP 7

Secure parts together using 4x PWM 2x6 mm screws

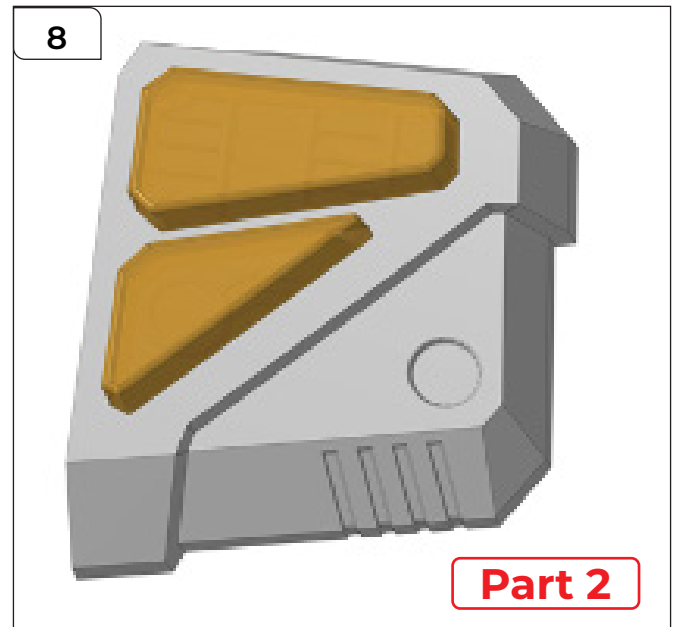

STEP 8

This is assembly now forms Part 2.

Assembling the Hip Wheels

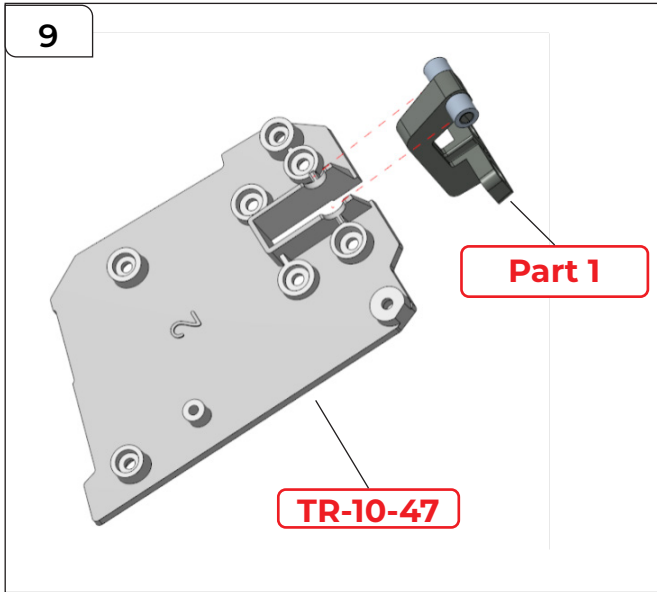

STEP 9

Take the remaining Part 1 assembly and attach it to TR-10-47.

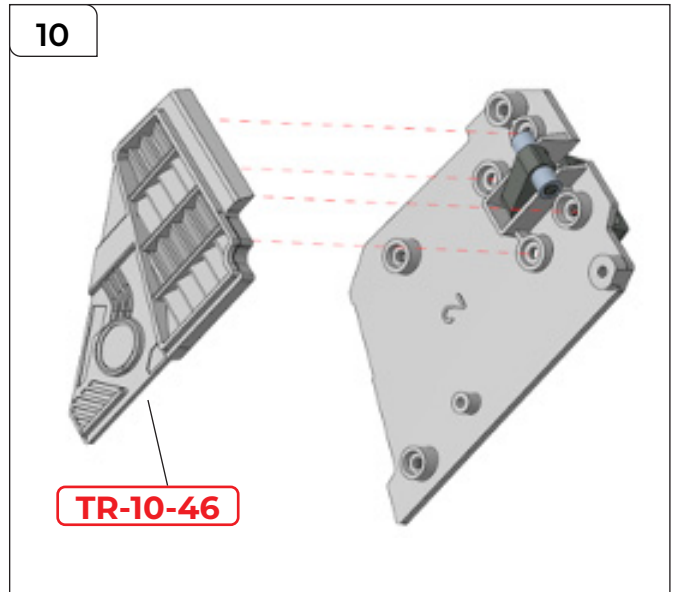

STEP 10

Place TR-10-46 over the top.

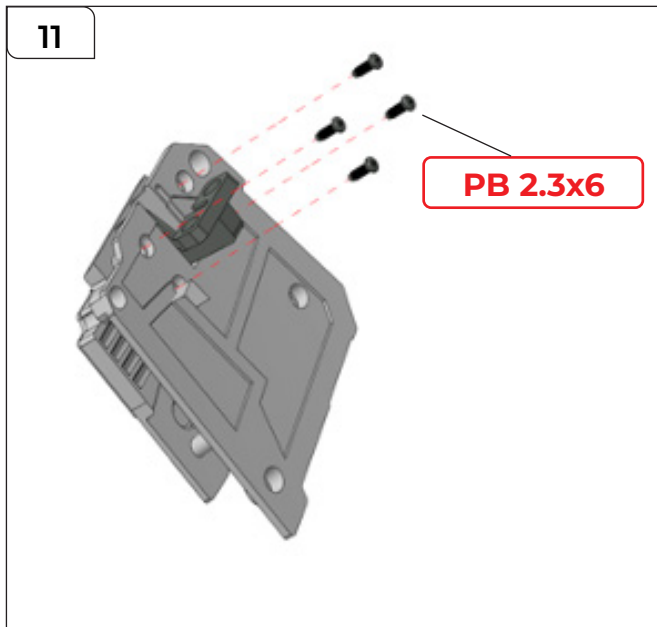

STEP 11

Secure parts in place from the reverse side using 4x PB2.3x6 mm screws.

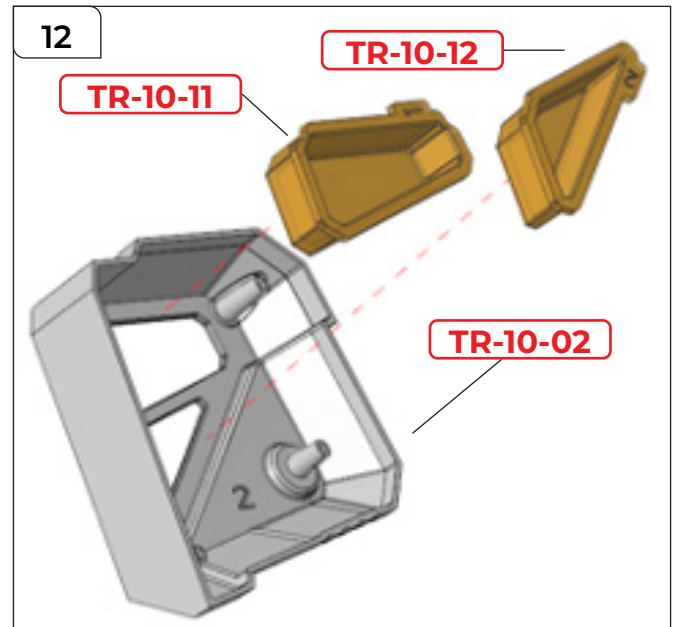

STEP 12

Place TR-10-11 and TR-10-12 onto TR-10-02.

Assembling the Hip Wheels

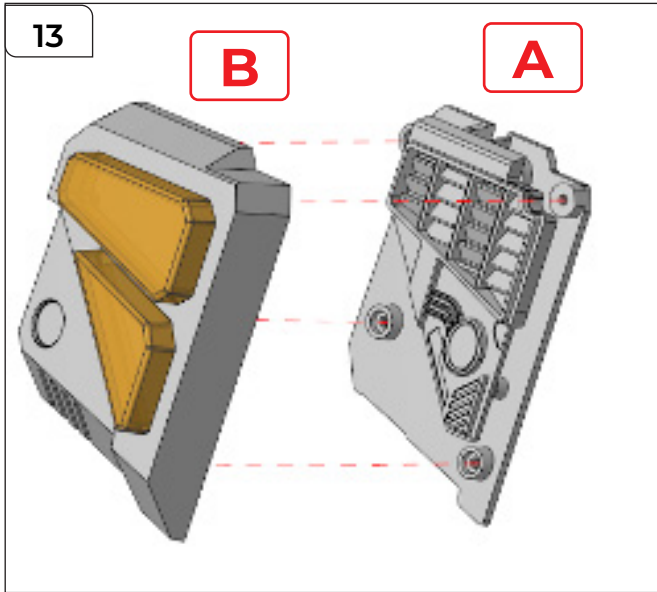

STEP 13

Attach the assemblies from the previous two steps (A & B) together as shown.

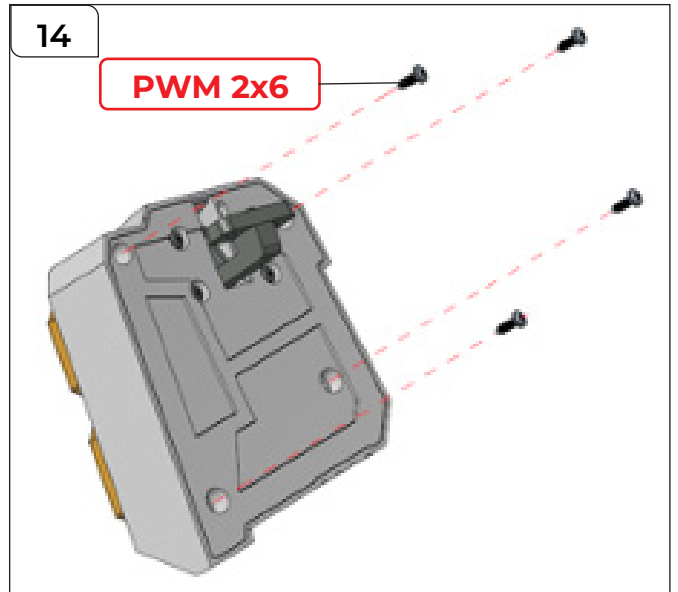

STEP 14

Secure them using 4x PWM 2x6 mm screws.

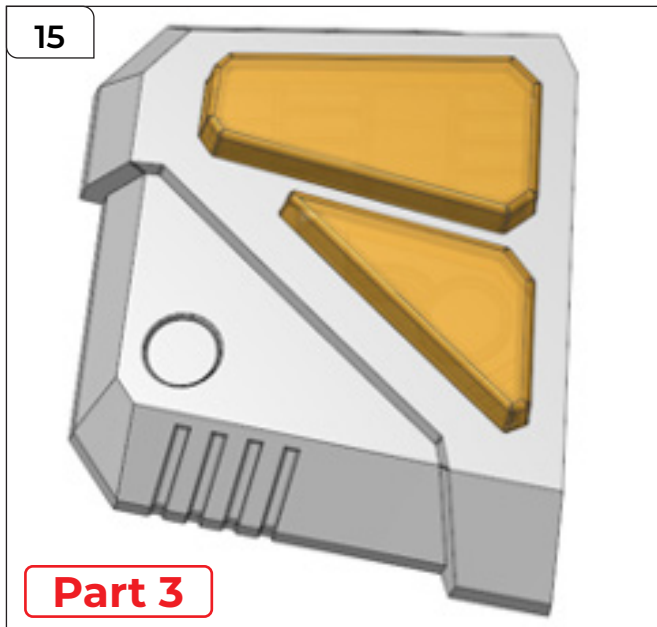

STEP 15

This assembly now forms Part 3.

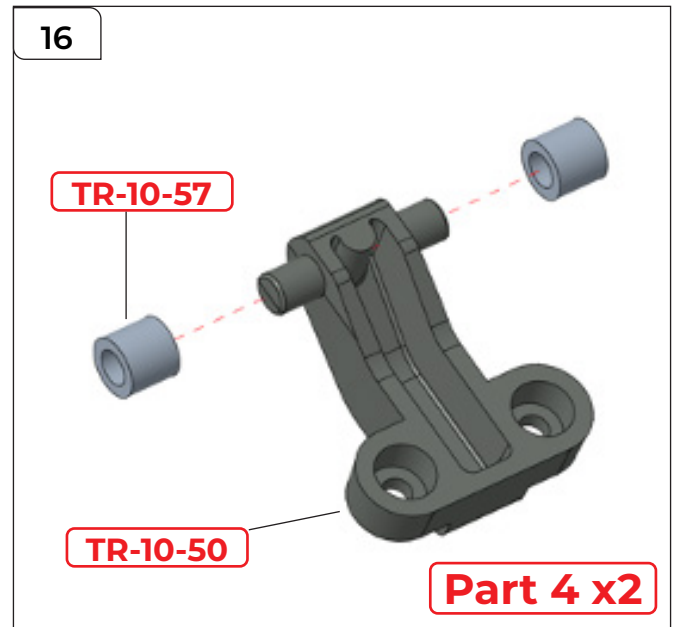

STEP 16

Push 2x TR-10-57 onto each post on TR-10-50. Repeat with another part TR-10-50 to make 2x Part 4 assemblies.

Assembling the Hip Wheels

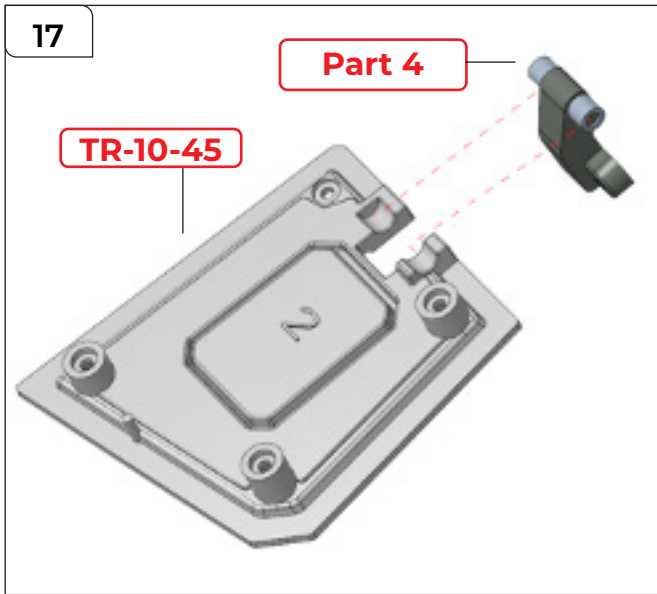

STEP 17

Attach 1x Part 4 to TR-10-45.

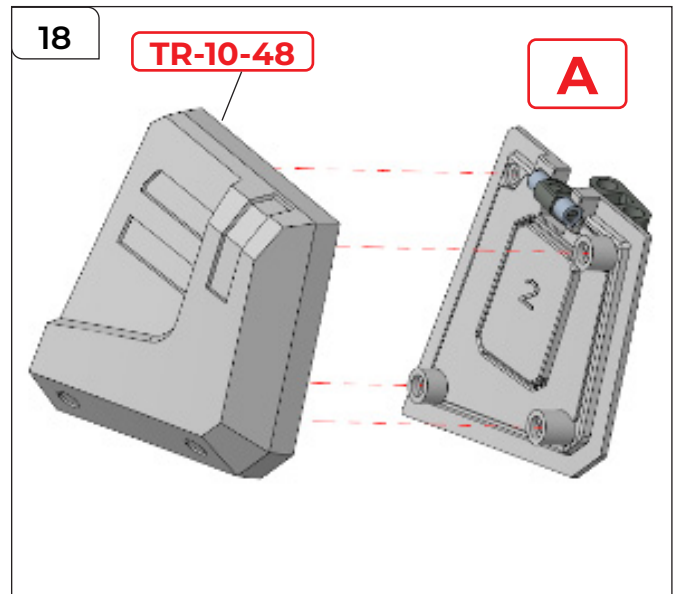

STEP 18

Place TR-10-48 onto TR-10-45 - on top of Part 4.

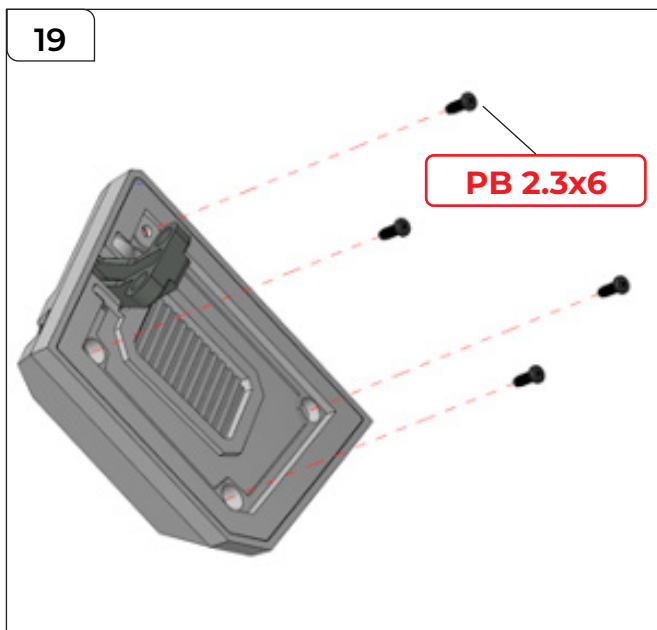

STEP 19

Secure parts from the reverse side using 4x PB 2.3x6 mm screws.

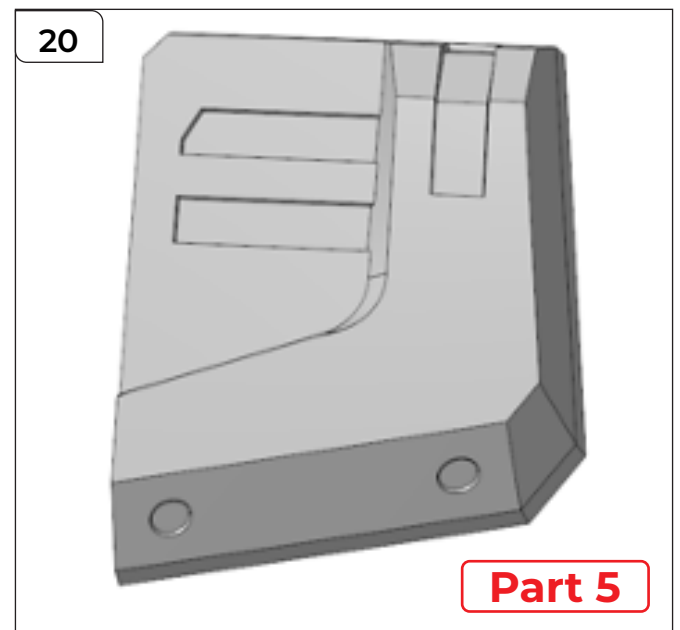

STEP 20

This assembly now forms Part 5.

Assembling the Hip Wheels

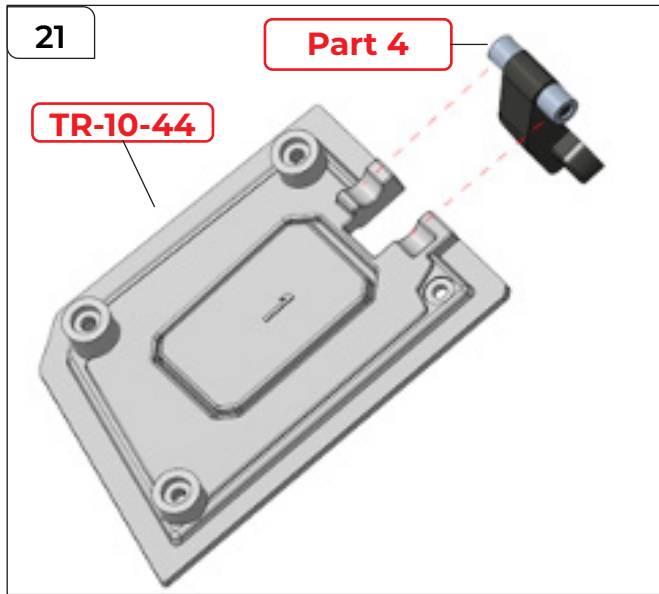

STEP 21

Take the remaining Part 4 assembly and attach it to TR-10-44.

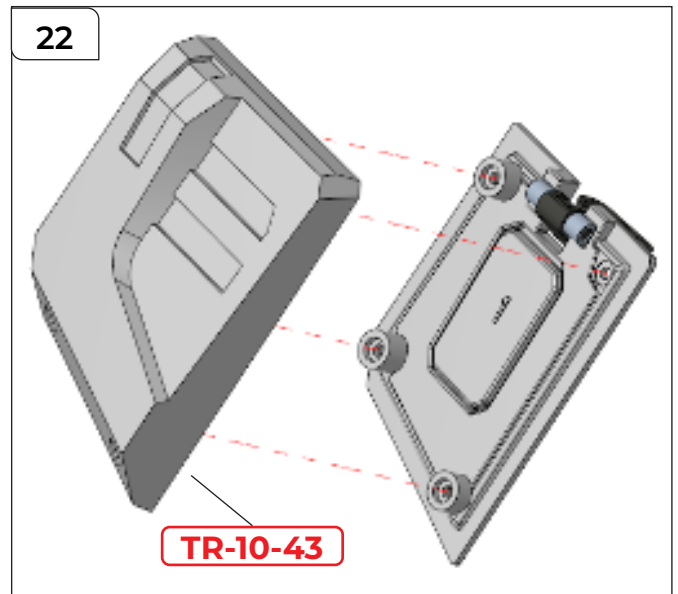

STEP 22

Place TR-10-43 on top.

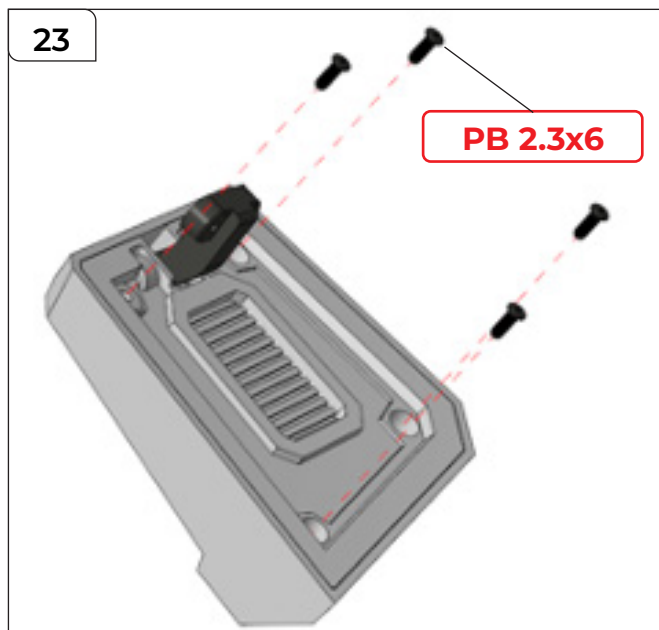

STEP 23

Secure the parts together using 4x PB 2.3x6 mm screws.

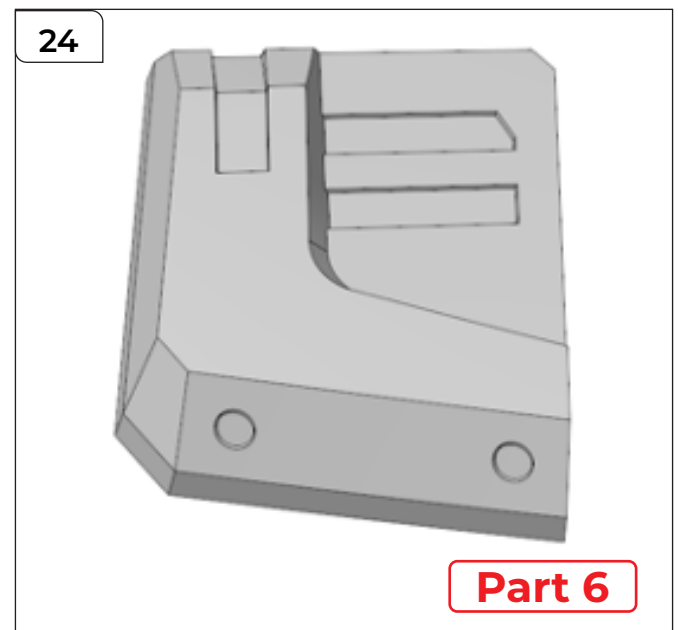

STEP 24

This assembly now forms Part 6.

Assembling the Hip Wheels

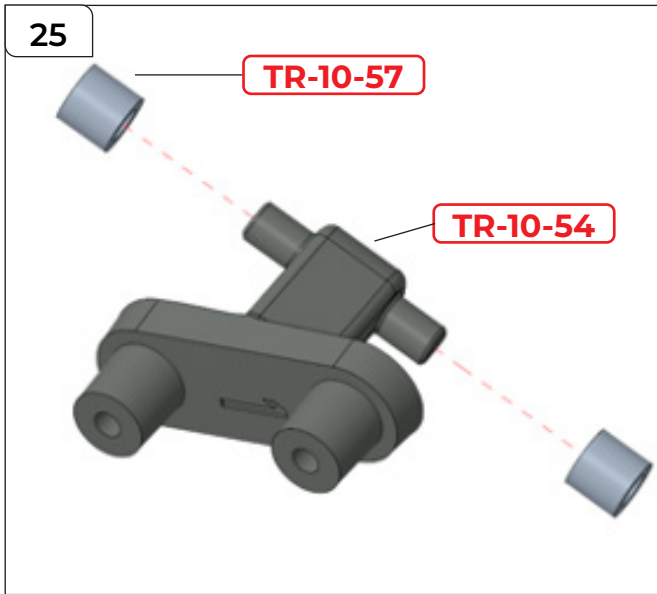

STEP 25

Push 2x TR-10-57 onto the posts on TR-10-54.

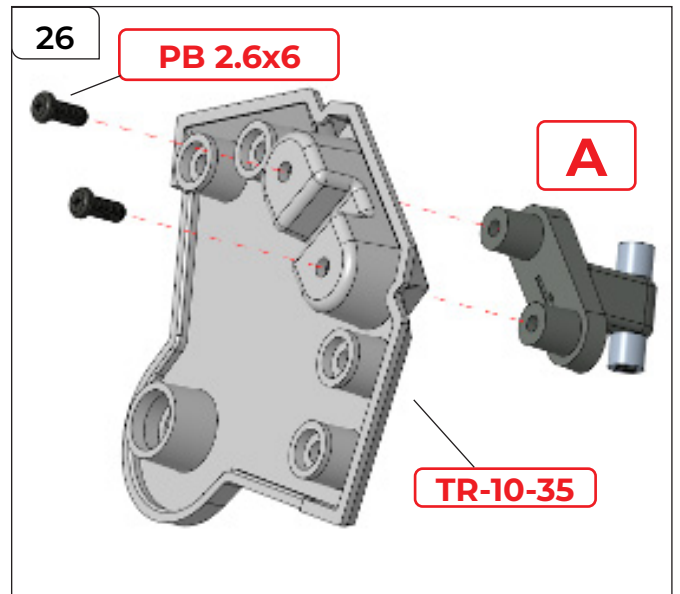

STEP 26

Attach the assembly from step 26 (A) to TR-10-35, securing them together using 2x PB 2.6x6 mm screws.



STEP 27

Fit TR-10-37 into the tyre TR-10-56.



STEP 28

This show the wheel parts correctly fitted together. The rim should fit securely inside the tyre with the inner edge of the tyre tucked under the lip on the rim.

Assembling the Hip Wheels

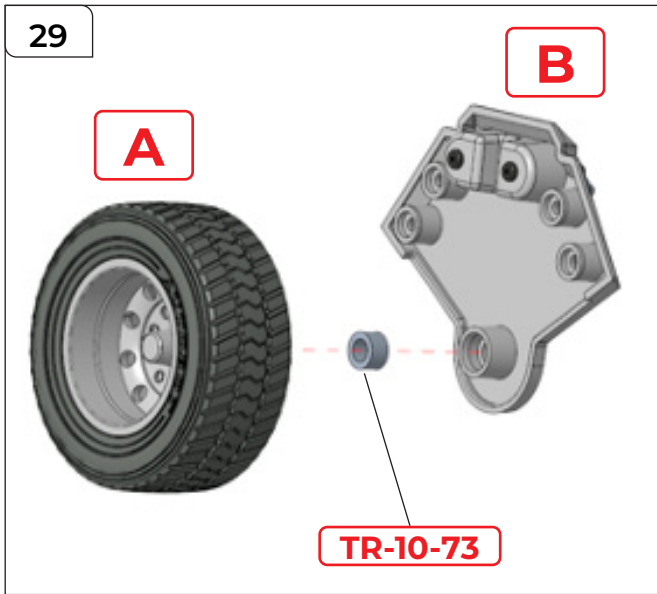

STEP 29

Fit TR-10-73 into the recess on B before fitting them to the wheel (A).

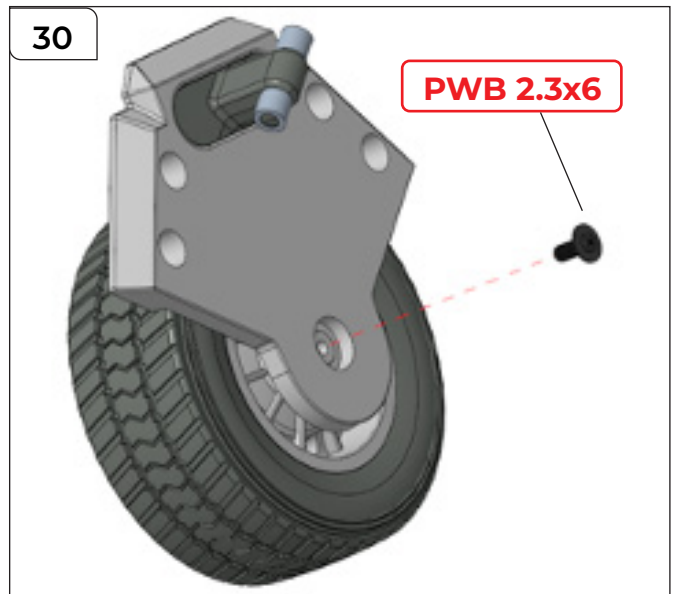

STEP 30

Secure the parts together using a PWB 2.3x6 mm screw to make assembly C.

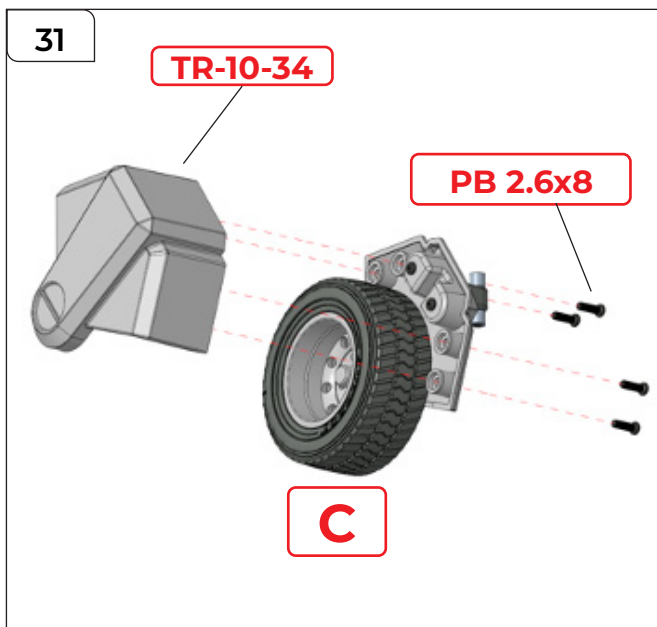

STEP 31

Attach TR-10-34 to assembly C and secure in place using 4x PB 2.6x8 mm screws.

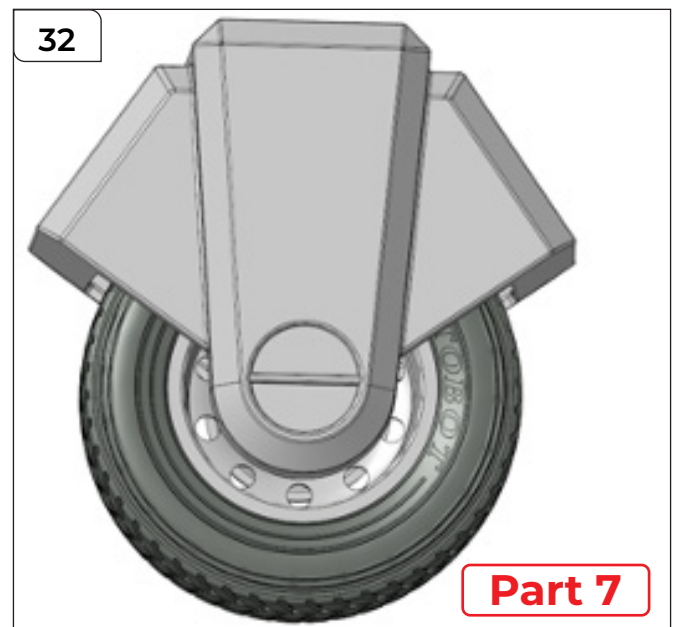

STEP 32

This assembly now forms Part 7.

Assembling the Hip Wheels

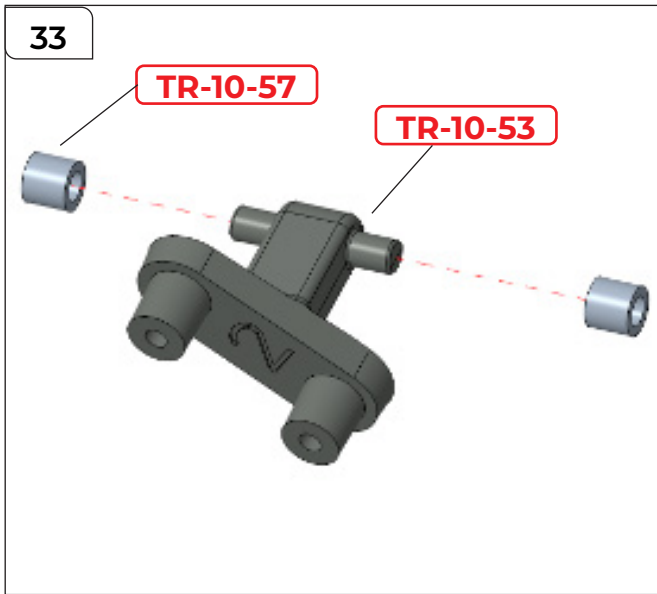

STEP 33

Push 2x TR-10-57 onto TR-10-53 to make assembly A.

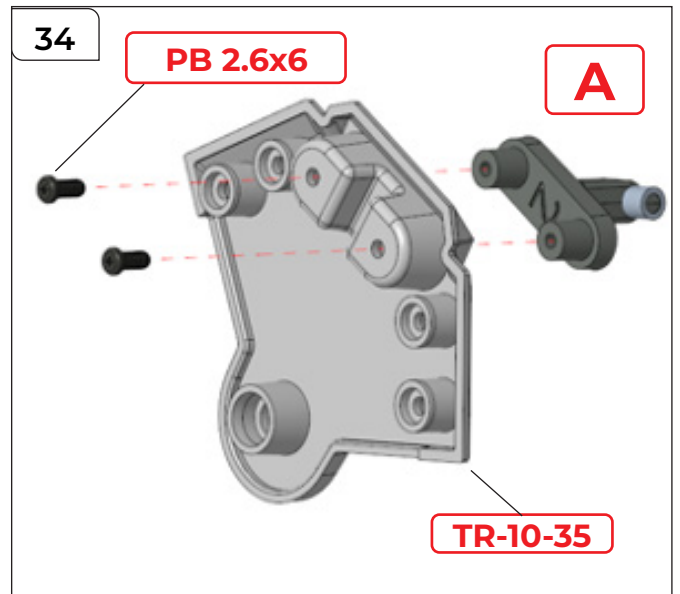

STEP 34

Attach assembly A to TR-10-35 and secure them together with 2x PB 2.6x6 mm screws.



STEP 35

Assemble another wheel by fitting TR-10-37 into TR-10-56.



STEP 36

Check the wheel rim fits snugly and securely inside the tyre.

Assembling the Hip Wheels

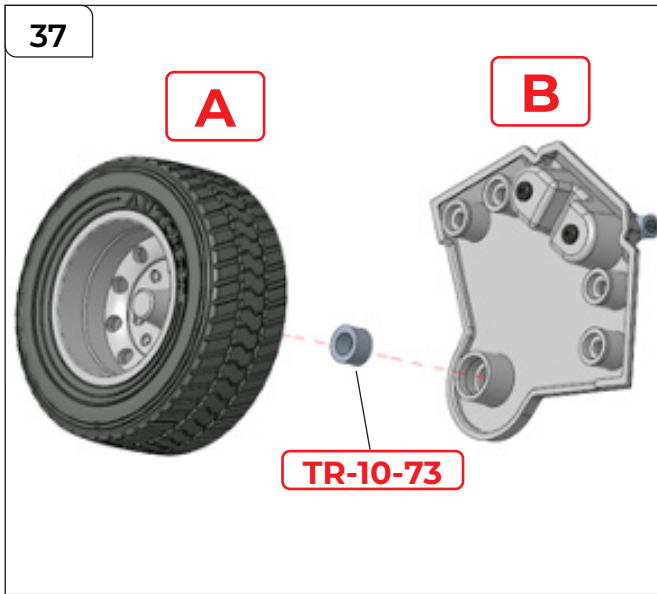

STEP 37

Fit TR-10-73 into the recess on assembly B before fitting them to the wheel (assembly A).

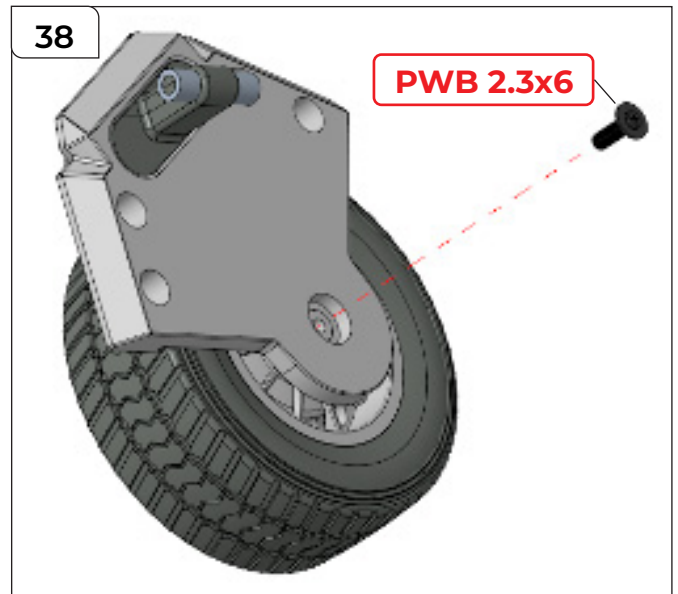

STEP 38

Secure the parts together using 1x PWB 2.3x6 mm screw to make assembly C.

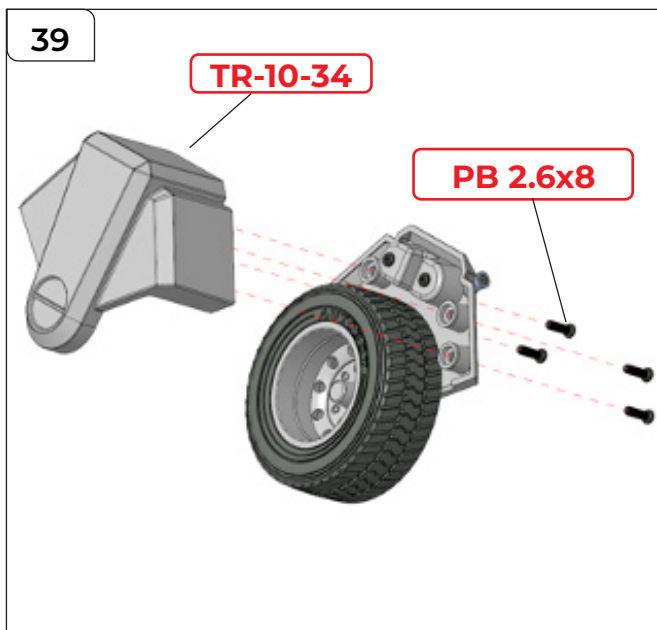

STEP 39

Attach TR-10-34 to assembly C and secure them using 4x PB 2.6x8 mm screws.

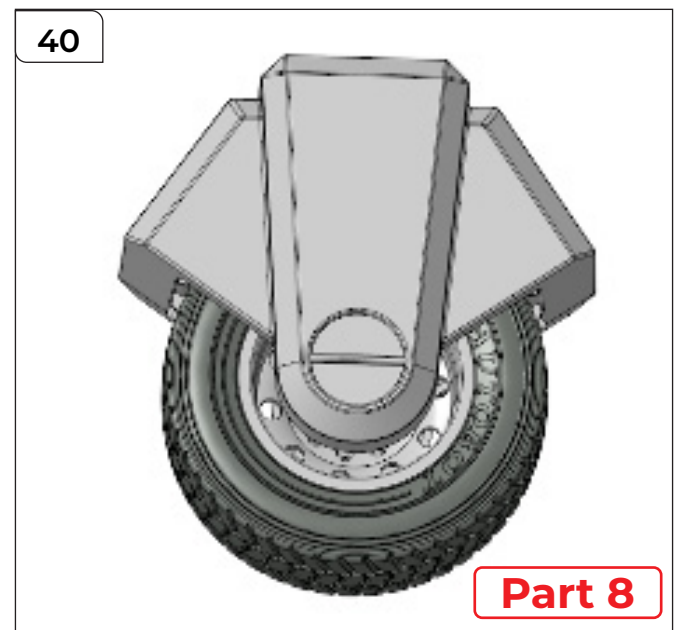

STEP 40

This assembly now forms Part 8.

Attaching the Wheels to the Hips

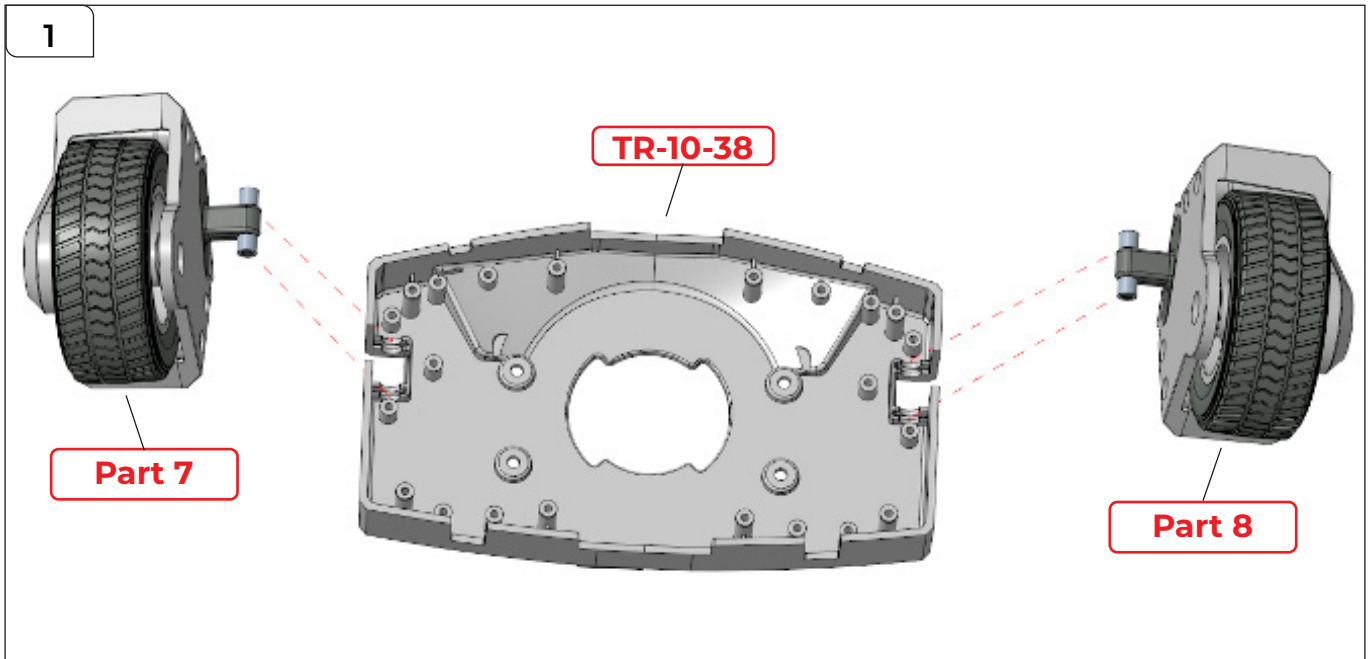

STEP 1

Take part TR-10-38 and align the wheel assemblies (Parts 7 & 8) on either side. Fit the wheels into each corresponding recess as shown.

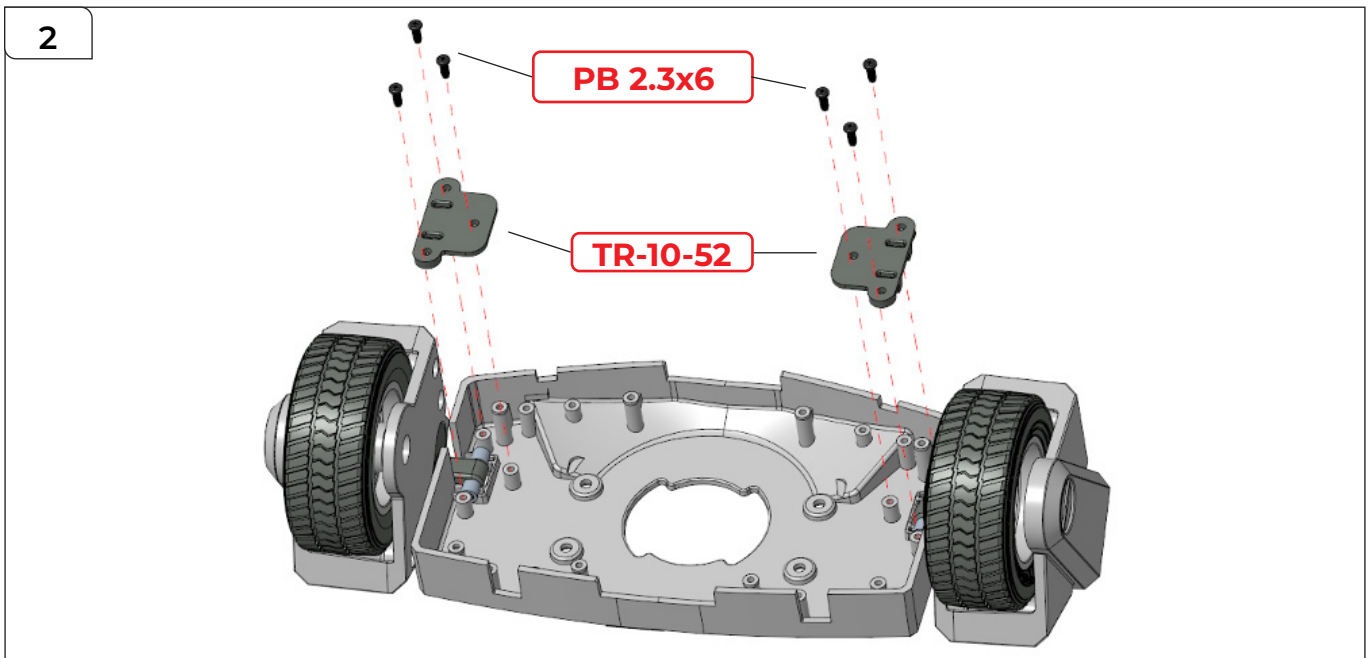

STEP 2

Fit 2x parts TR-10-52 over the wheel brackets and secure them using 6x PB 2.3x6 mm screws.

Attaching the Wheels to the Hips

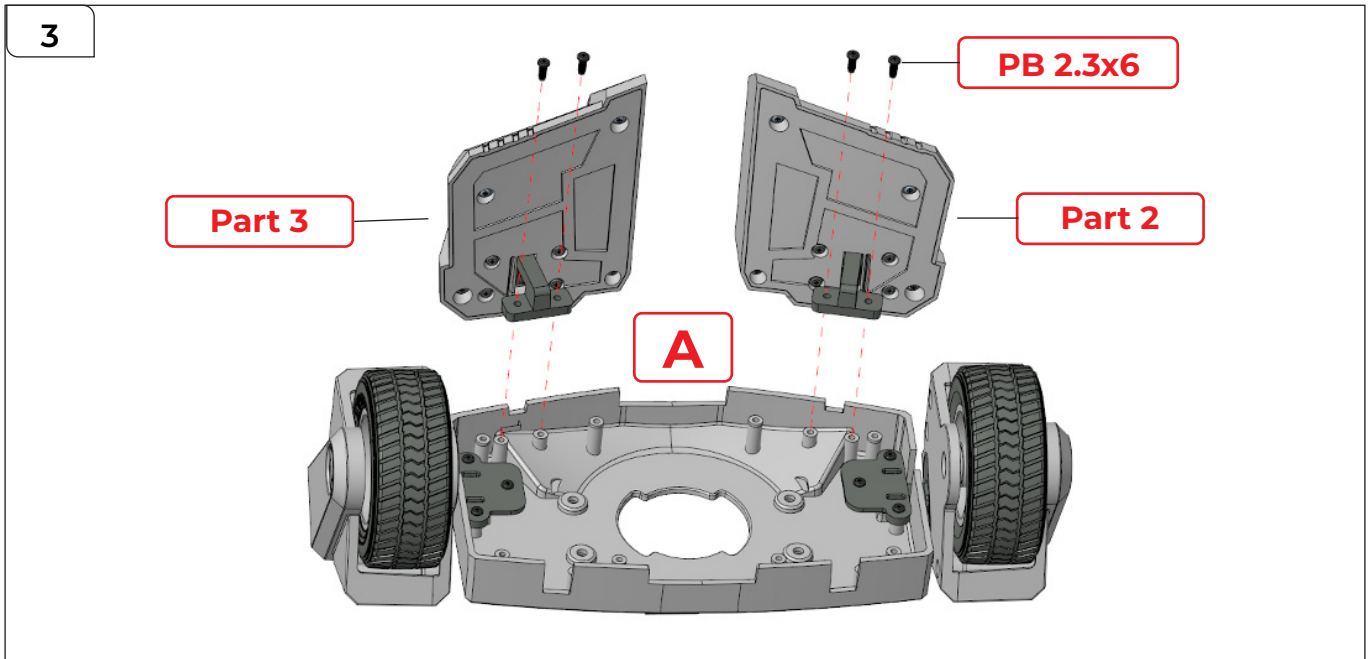

STEP 3

Take the assemblies labelled Part 2 and Part 3 above, and fit them to assembly A as shown. Secure in place using 4x PB 2.3x6 mm screws.

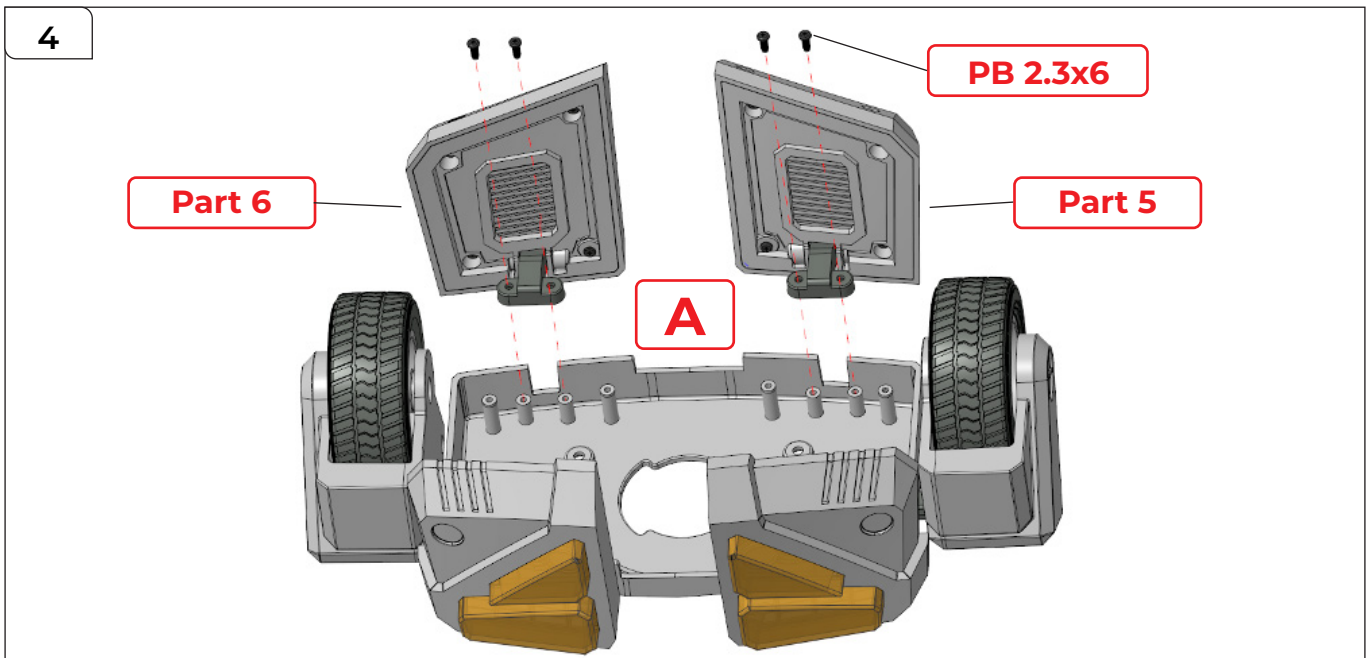

STEP 4

Take the assemblies labelled Part 5 & Part 6 and fit them to the opposite side of assembly A. Secure using 4x PB 2.3x6 mm screws.

Attaching the Wheels to the Hips

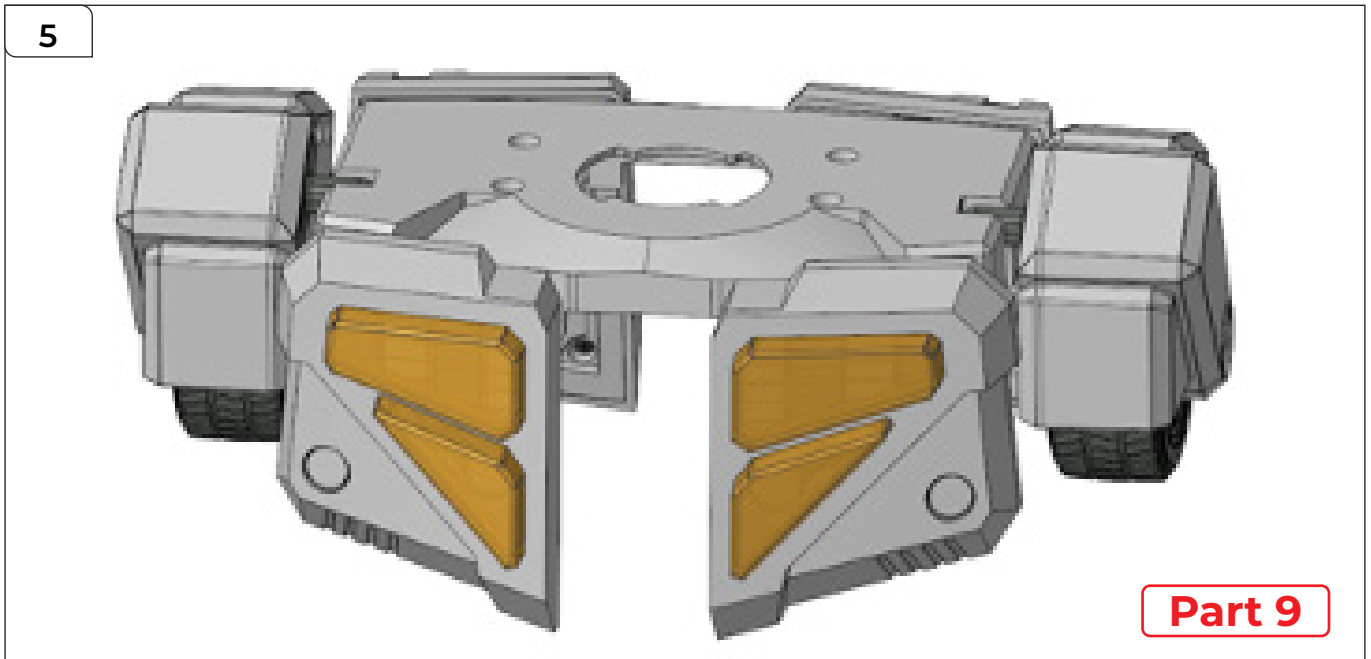

STEP 5

This assembly now forms Part 9.

Assembling the Upper Left Leg

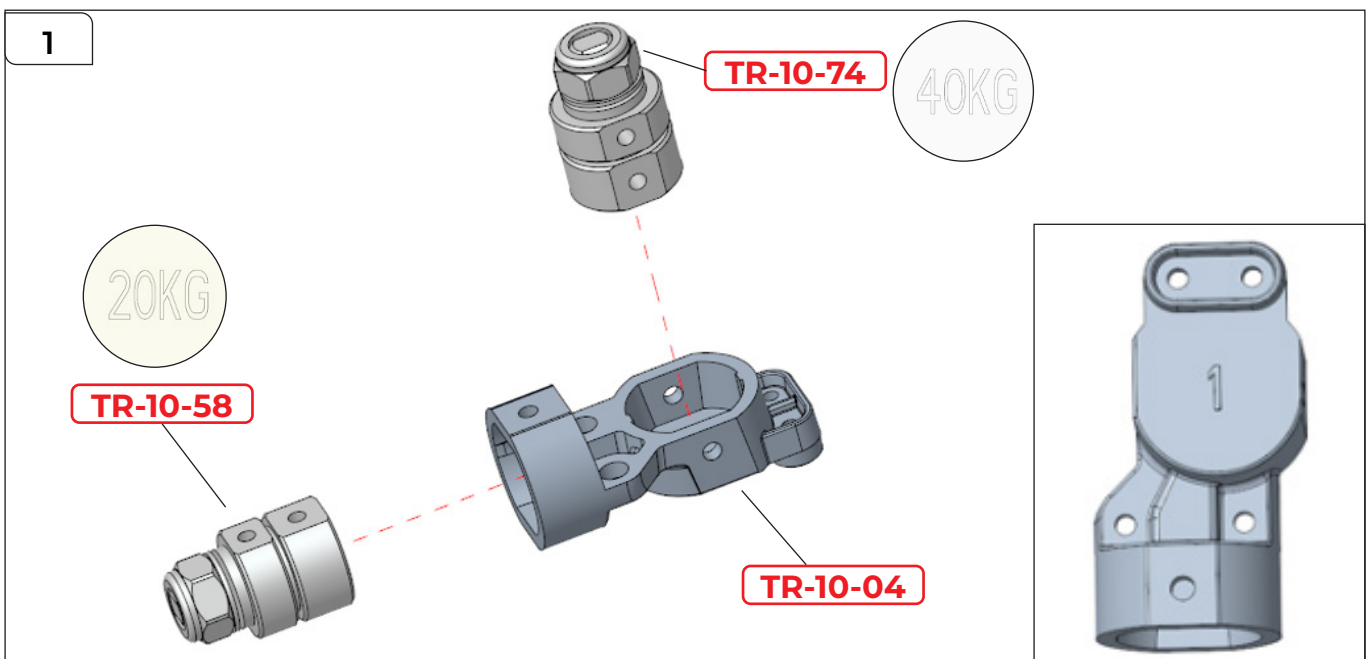

STEP 1

Correctly identify the parts above by checking the torque values given on the end of parts TR-10-58 & TR-10-74. Part TR-10-04 is marked with a number '1'. Hold TR-10-04 in the orientation shown and fit the widest end of parts 58 and 74 into the recesses.

Assembling the Upper Left Leg

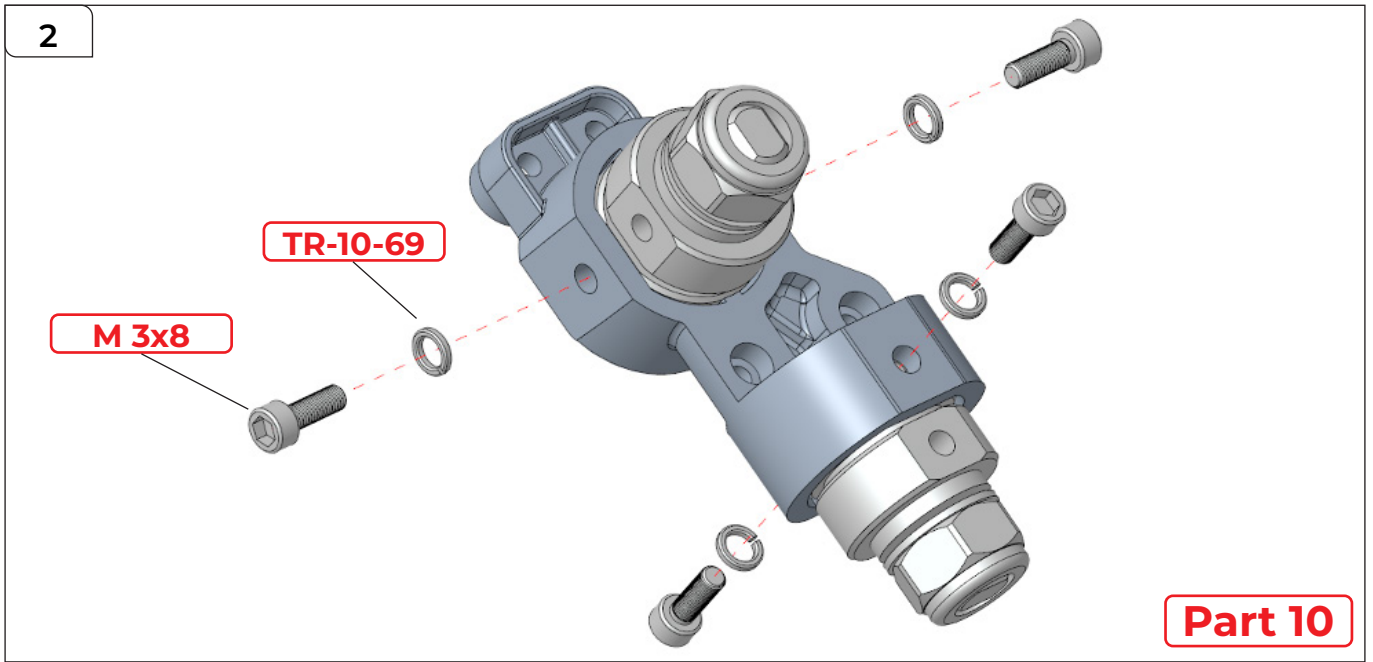

STEP 2

Secure the parts together using 4x TR-10-69 washers fitted onto 4x M 3x8 mm screws. This now forms assembly Part 10.

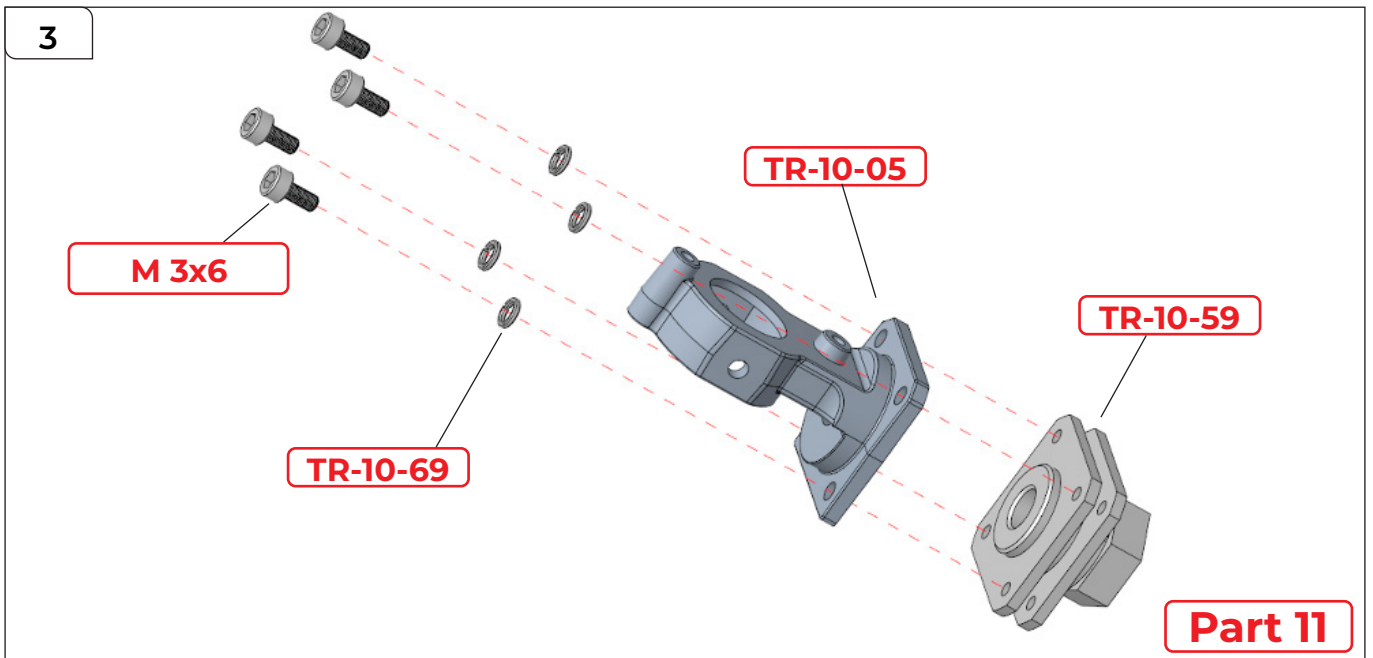

STEP 3

Attach TR-10-05 to TR-10-59 and secure them using 4 x TR-10-69 washers fitted to 4x M 3x6 mm screws. This now forms assembly Part 11.

Assembling the Upper Left Leg

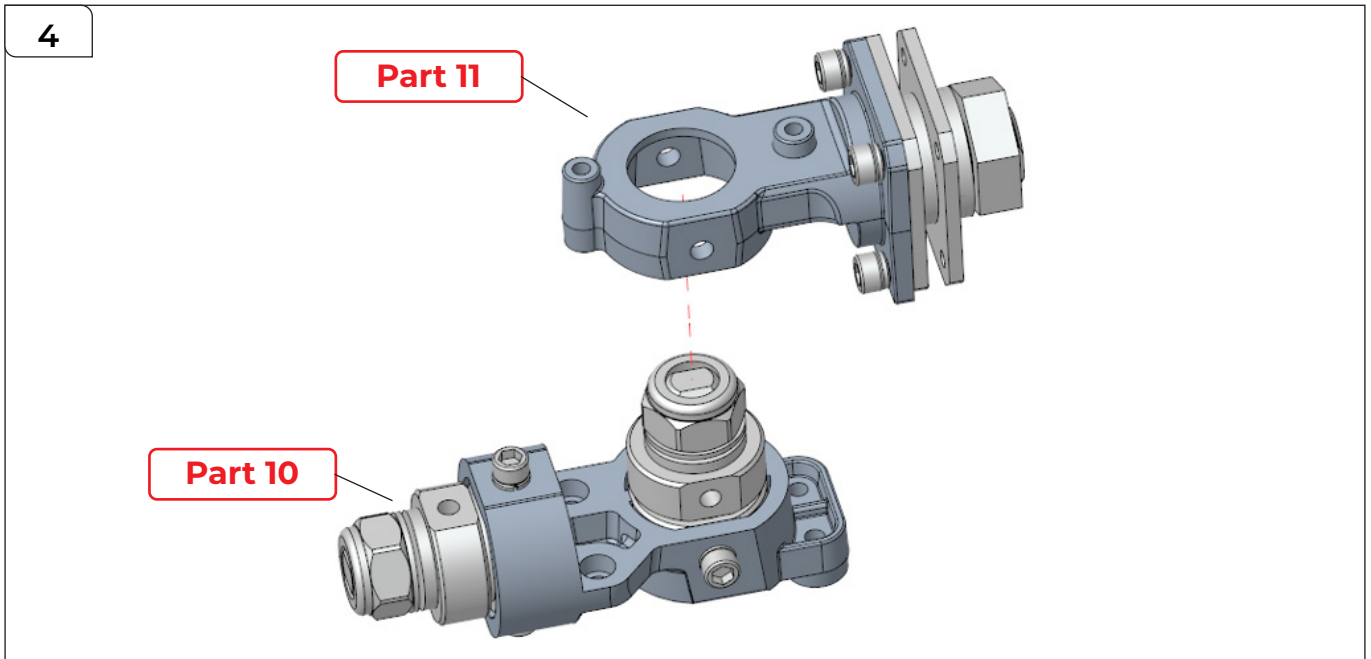

STEP 4

Fit assembly Part 11 to assembly Part 10 as shown.

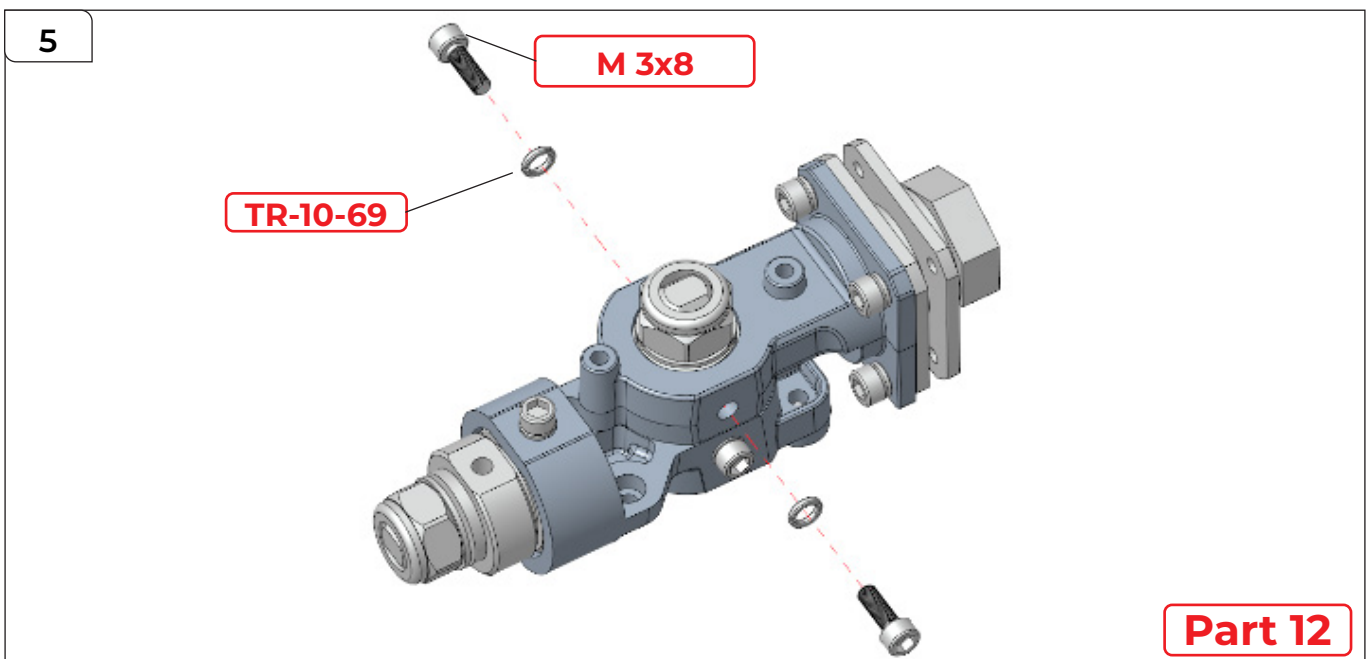

STEP 5

Secure the parts together using 2x TR-10-69 washers fitted to 2x M 3x8 mm screws. This now forms assembly part 12.

Assembling the Upper Left Leg

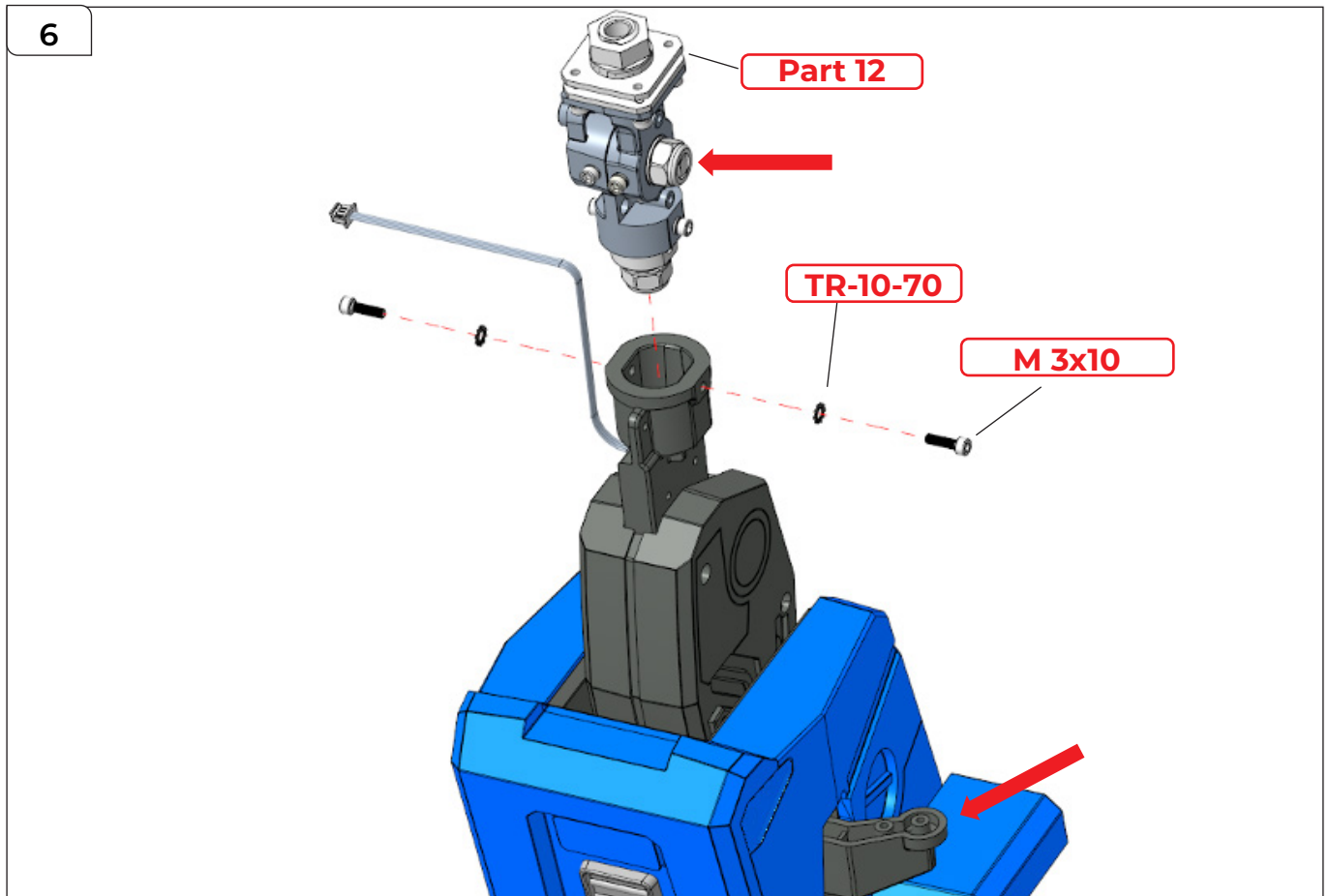

STEP 6

Take the lower left leg assembled in pack 8 and position assembly Part 12 into the opening at the top of the leg as shown. **Pay close attention to the direction, ensuring the parts indicated with an arrow are facing the same side.** Secure the parts together using 2x TR-10-70 washers fitted to 2x M 3x10 mm screws.

Assembling the Upper Left Leg

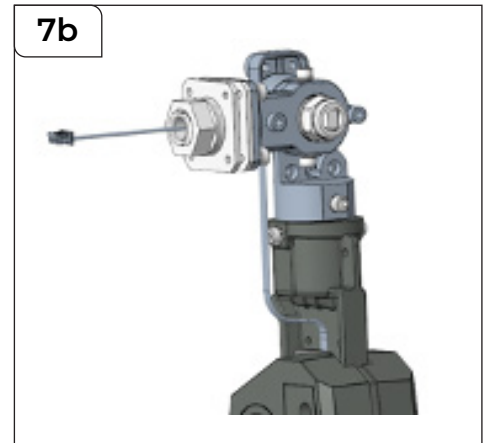
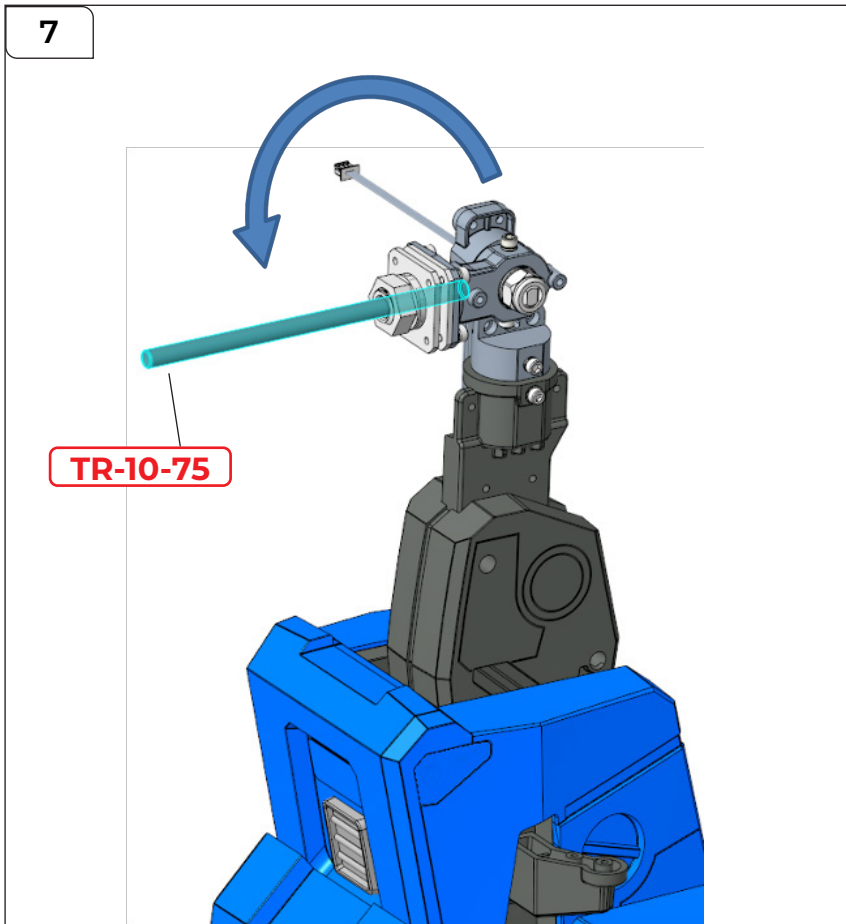

STEP 7

First, use the metal rod (TR-10-75) to turn the joint through 90 degrees downwards.

Then, keeping the rod in place, turn the joint through 90 degrees in a horizontal motion.

Now feed the wire through the opening in Part 12 as shown in 7b above.

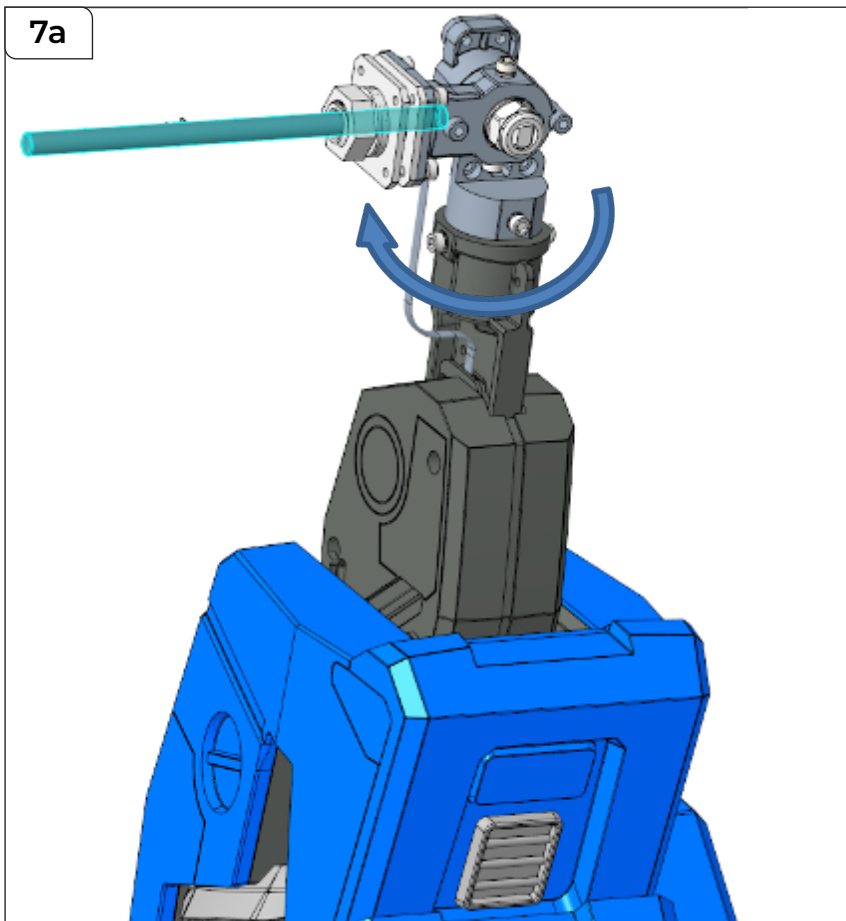

Assembling the Upper Left Leg

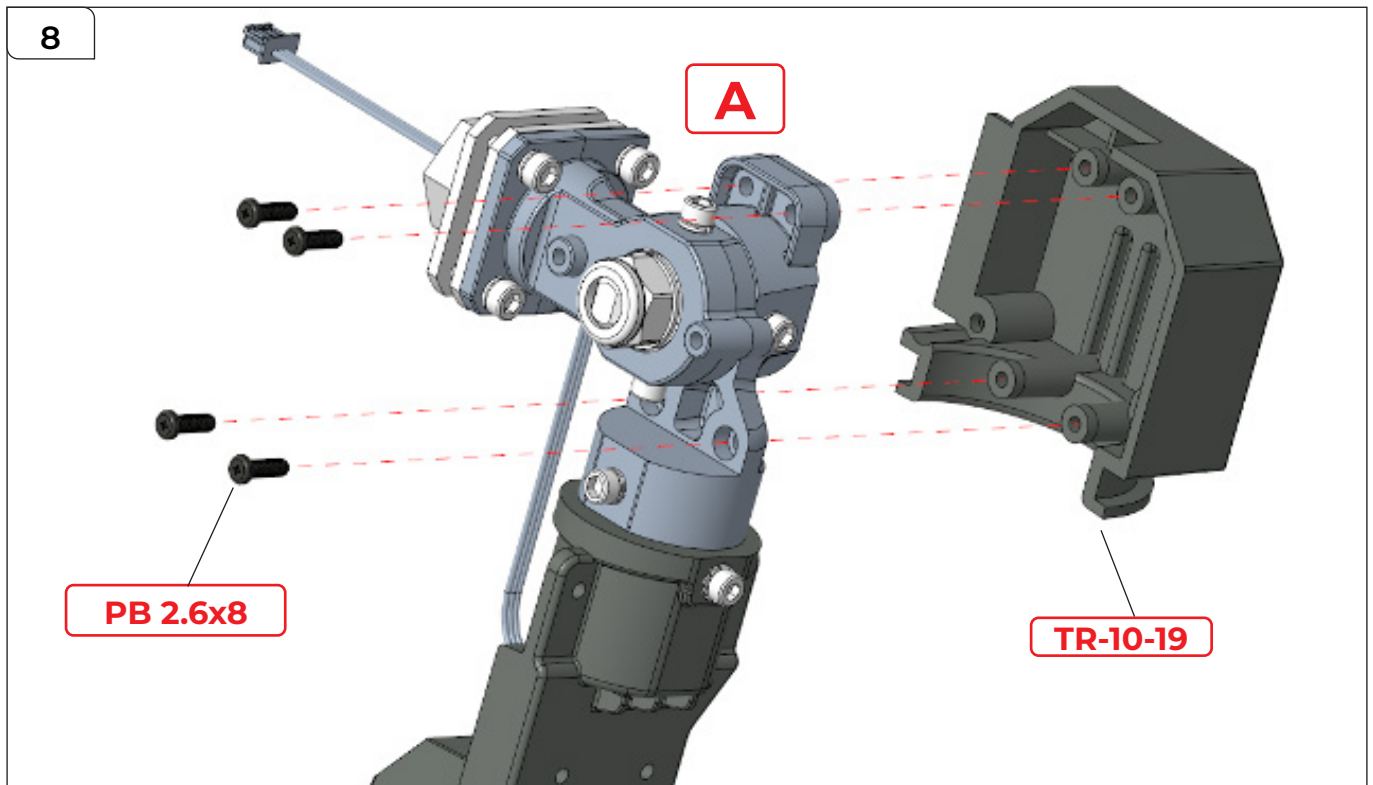

STEP 8

Fit part TR-10-19 to the joint (A) as shown, securing it place with 4x PB 2.6x8 mm screws.

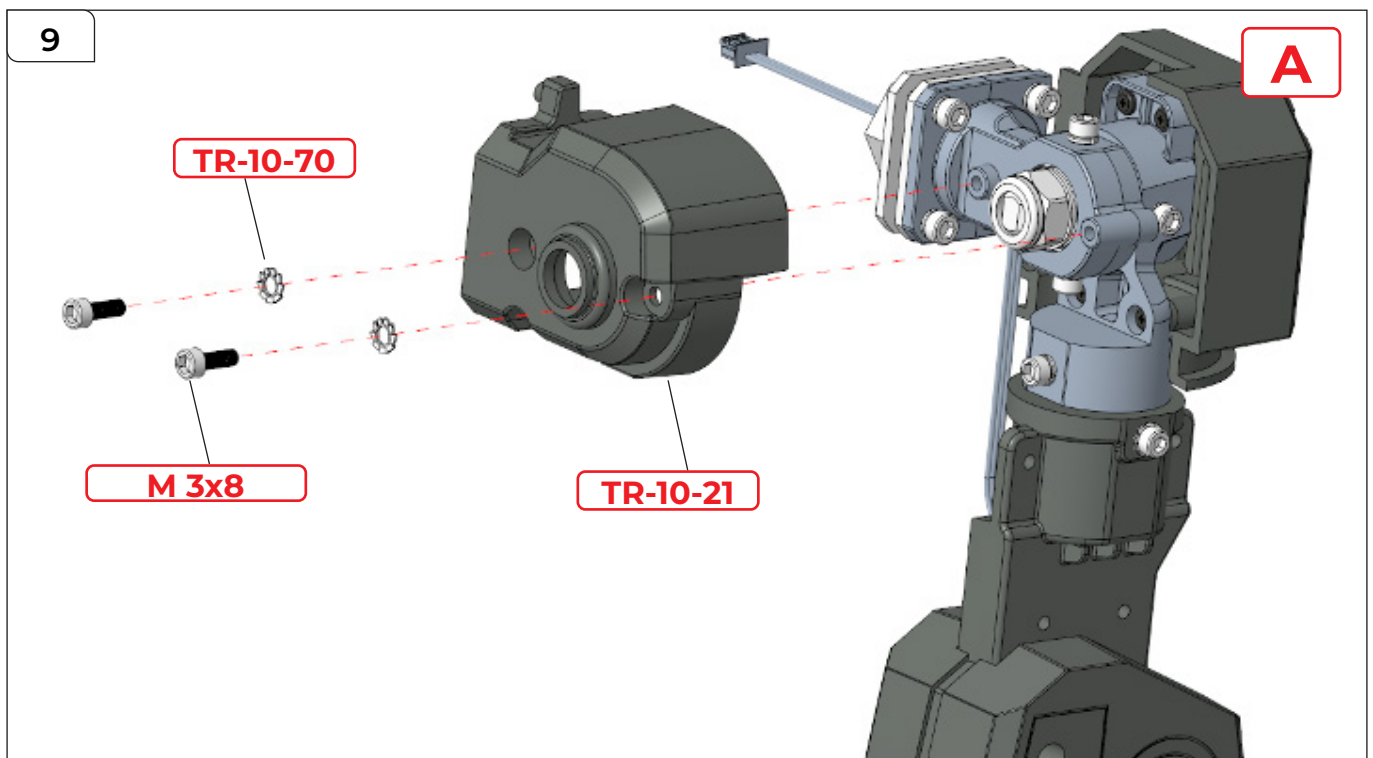

STEP 9

Fit part TR-10-21 to the opposite side of the joint (A), securing it in place with 2x TR-10-70 washers fitted onto 2x M 3x8 screws.

Assembling the Upper Left Leg

10

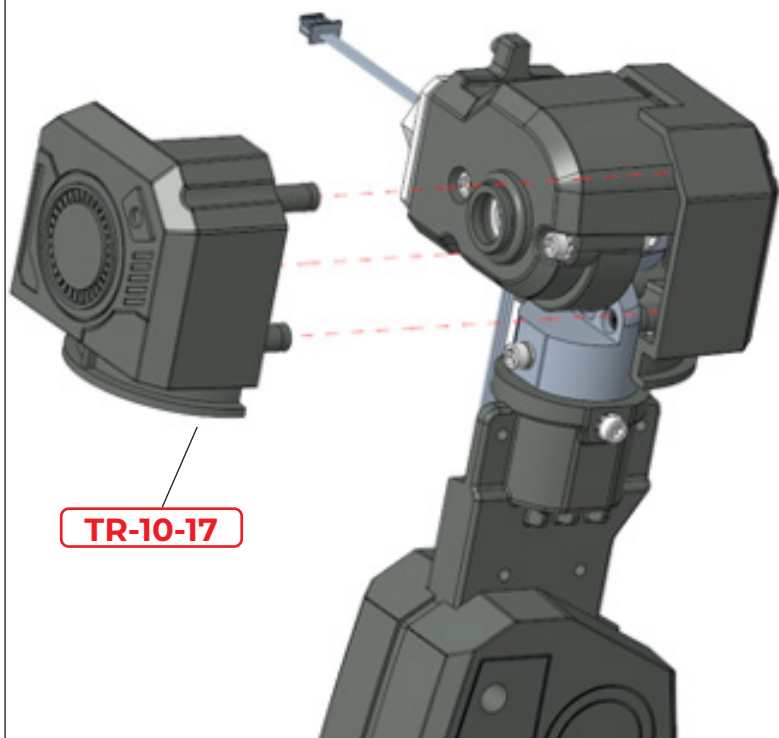

STEP 10

Fit TR-10-17 over the top.

11

PB 2.6x8

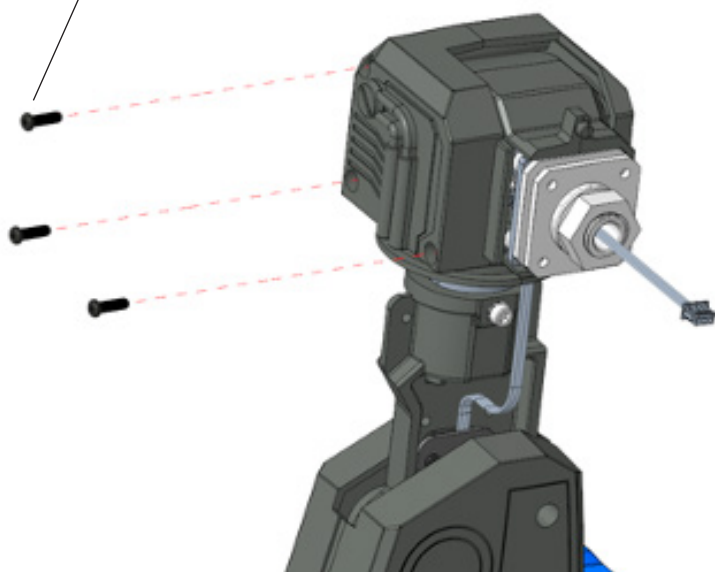

STEP 11

Secure it using 3x PB 2.6x8 mm screws.

Assembling the Upper Left Leg

12

STEP 12

Take TR-10-22 and TR-10-49 and attach them together as shown. Secure them using 4x PB 2.6x8 mm screws. This now forms Part 13.

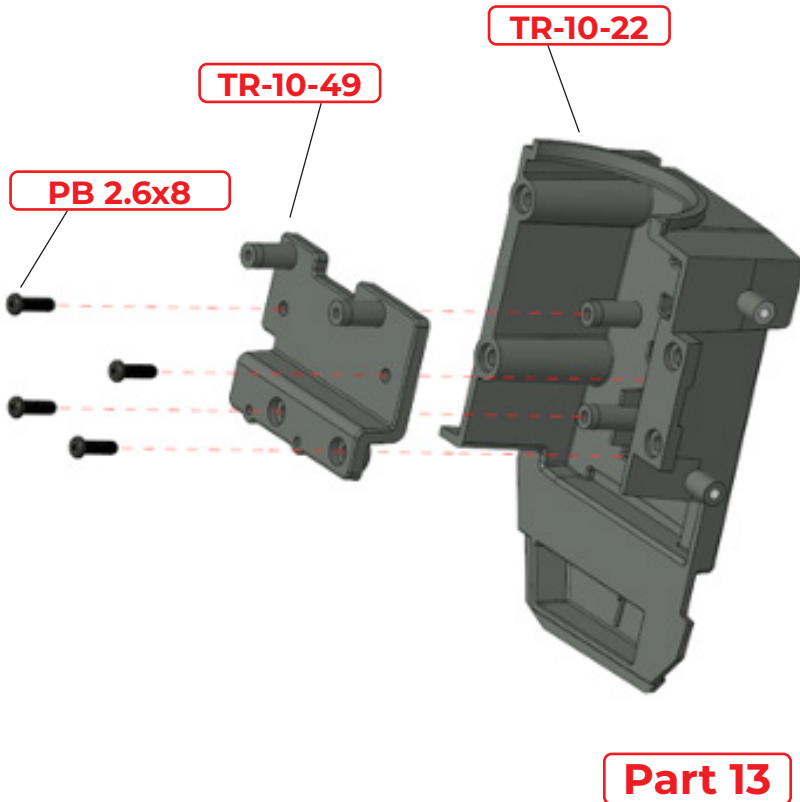

13

STEP 13

Take part TR-10-23 and fix part TR-10-36 into the circular recess as shown. Secure it from the reverse side with a PB 2.6x6 mm screw. This now forms Part 14.

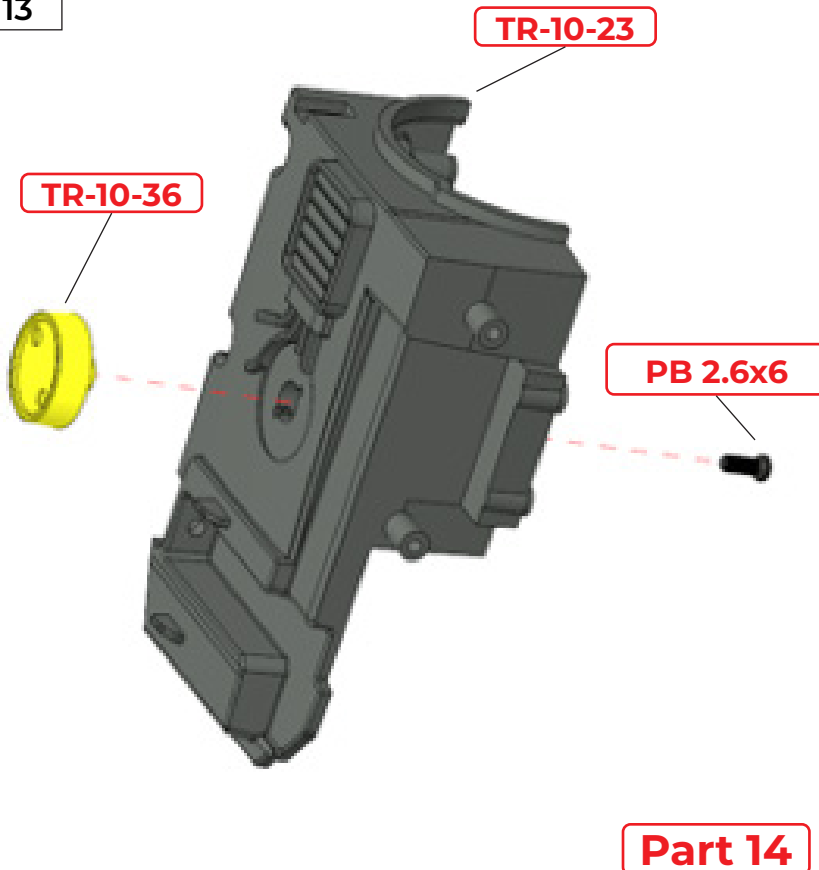

Assembling the Upper Left Leg

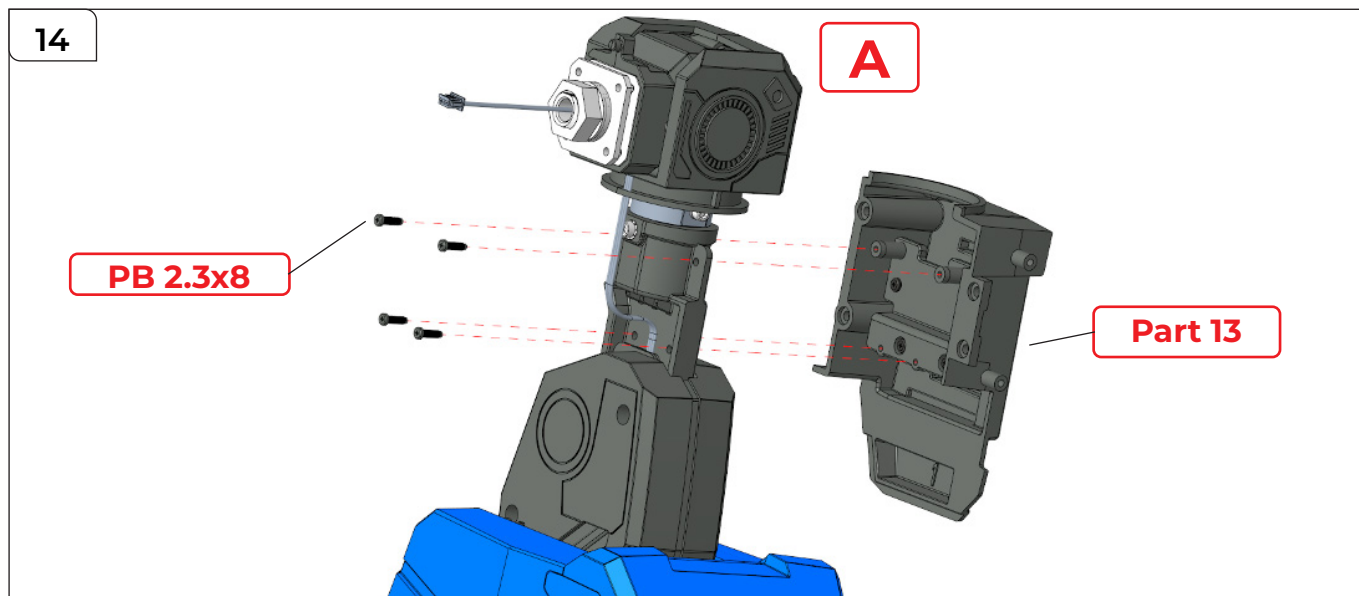

STEP 14

Fit assembly Part 13 to the top of the leg (A), securing it using 4x PB 2.3x8 mm screws.

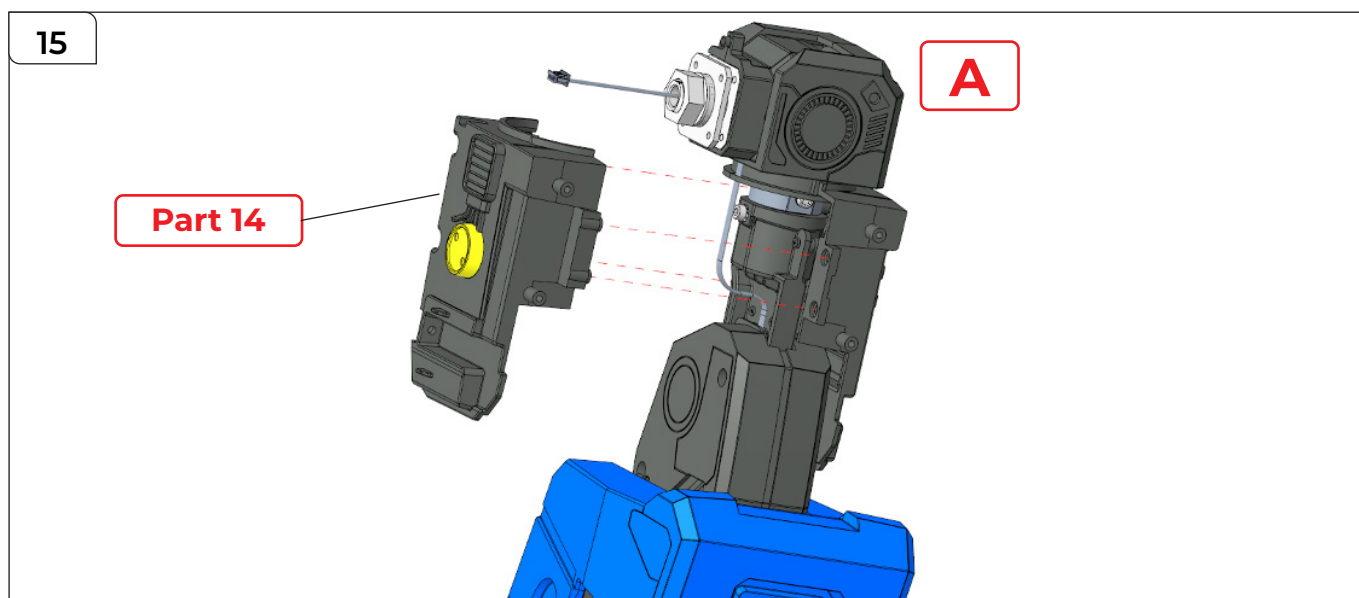

STEP 15

Fit assembly Part 14 to the opposite side.

Assembling the Upper Left Leg

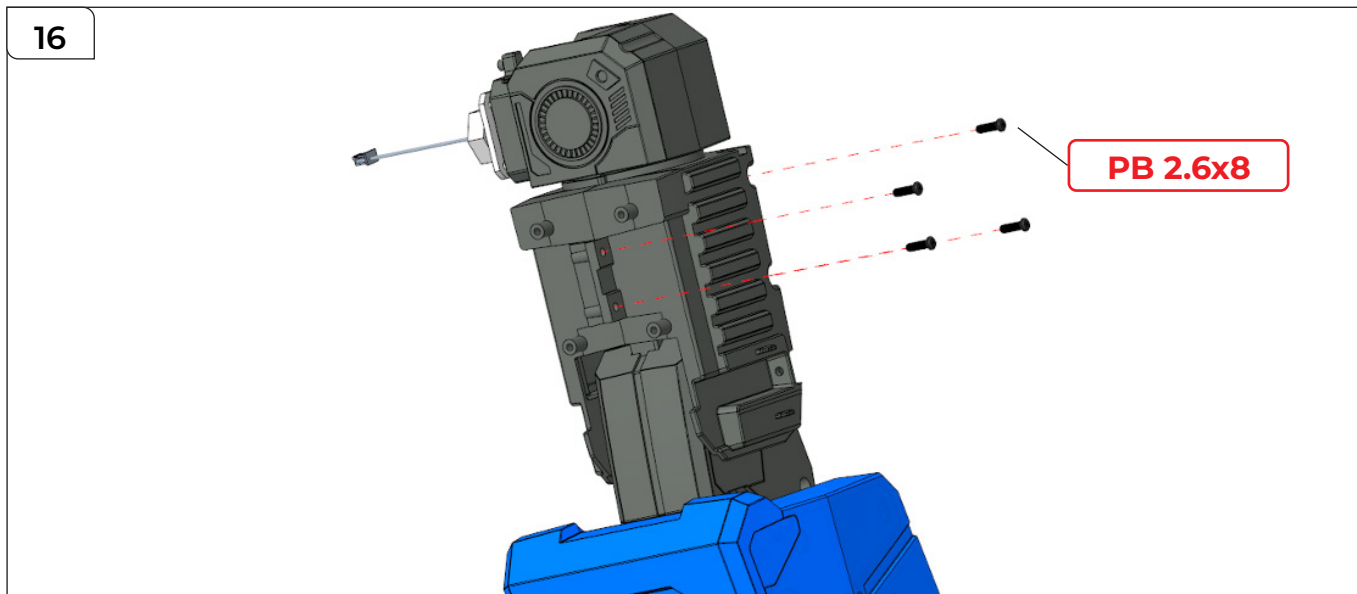

STEP 16

Secure Part 14 from the opposite side using 4x PB 2.6x8 mm screws.

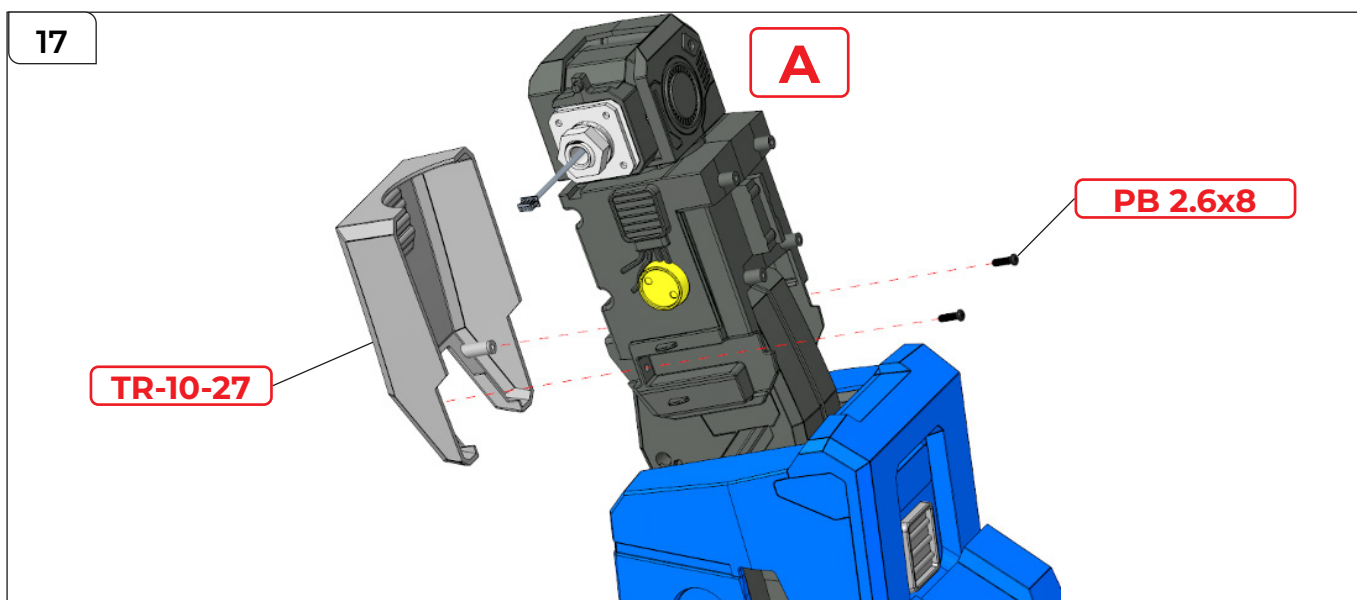

STEP 17

Attach TR-10-27 in the orientation shown and secure using 2x PB 2.6x8 mm screws.

Assembling the Upper Left Leg

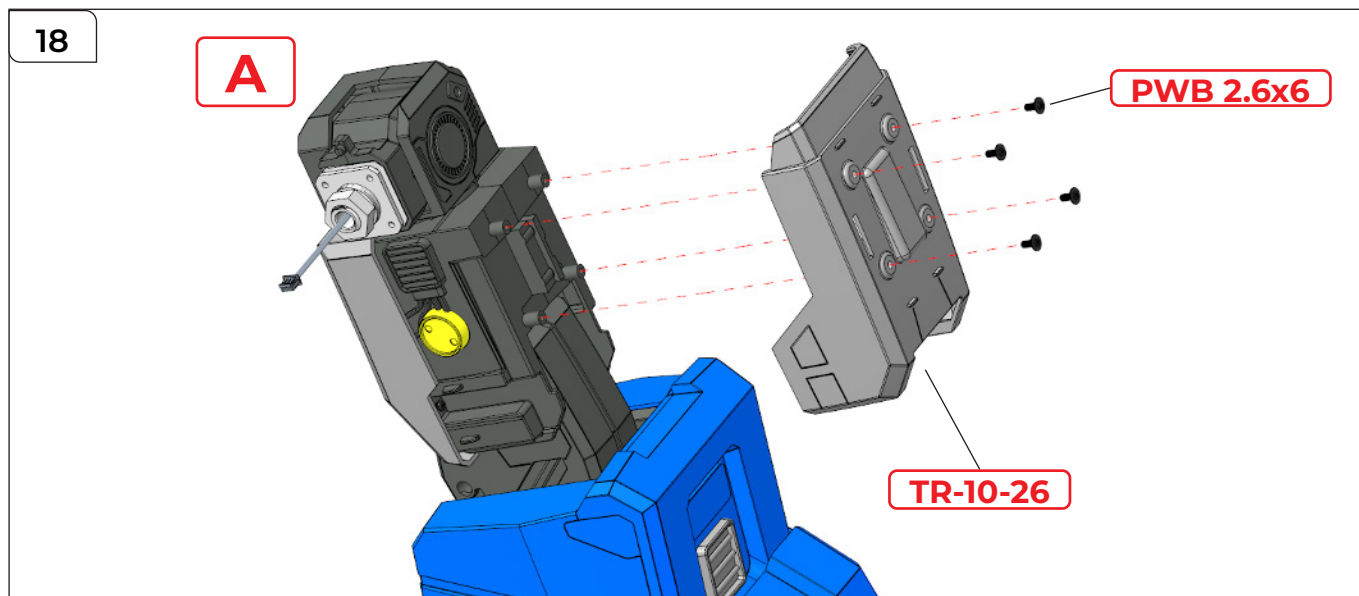

STEP 18

Attach TR-10-26 to the opposite side and secure using 4x PWB 2.6x6 mm screws.

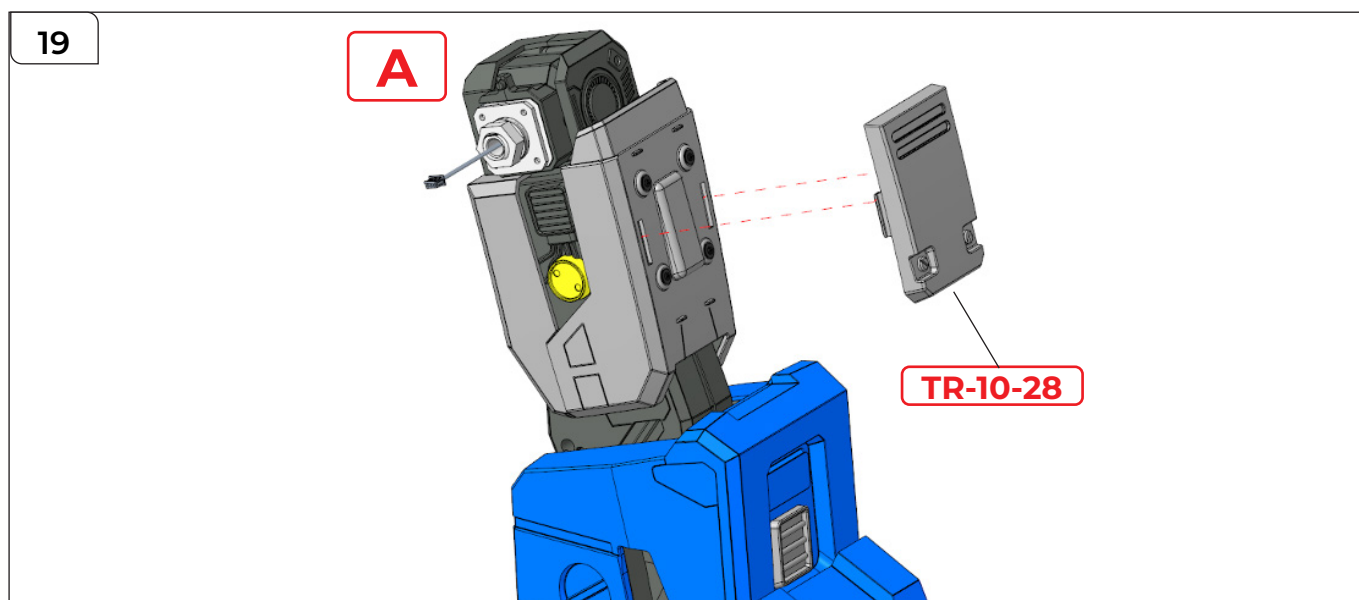

STEP 19

Push TR-10-28 on top, covering the screws.

Assembling the Upper Left Leg

20

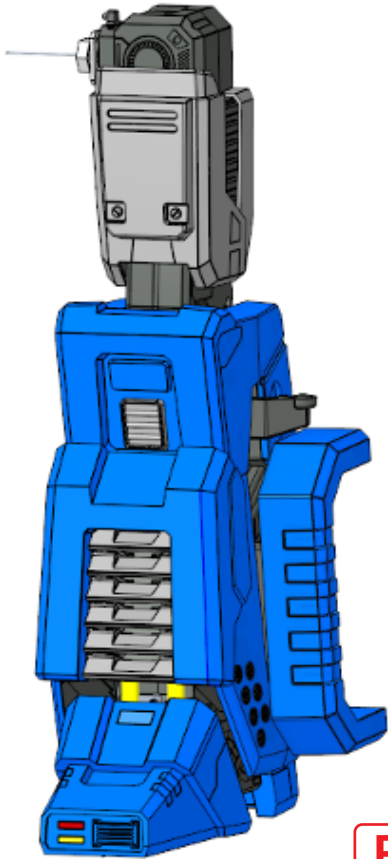

Part 15

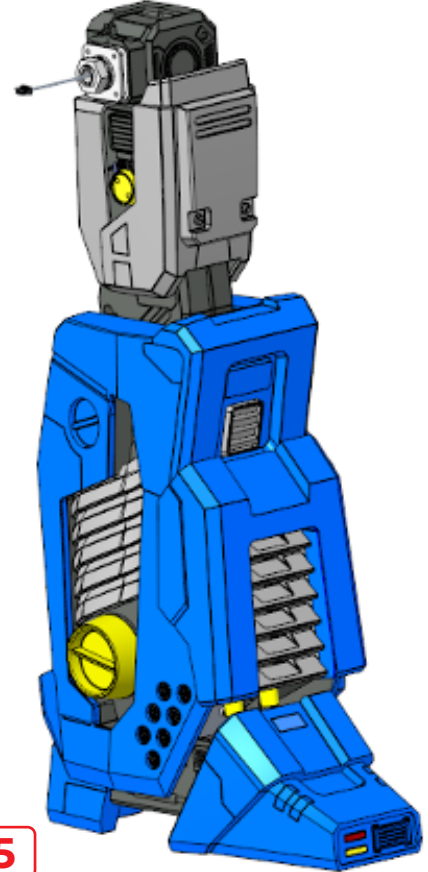

Part 15

Assembling the Upper Right Leg

1

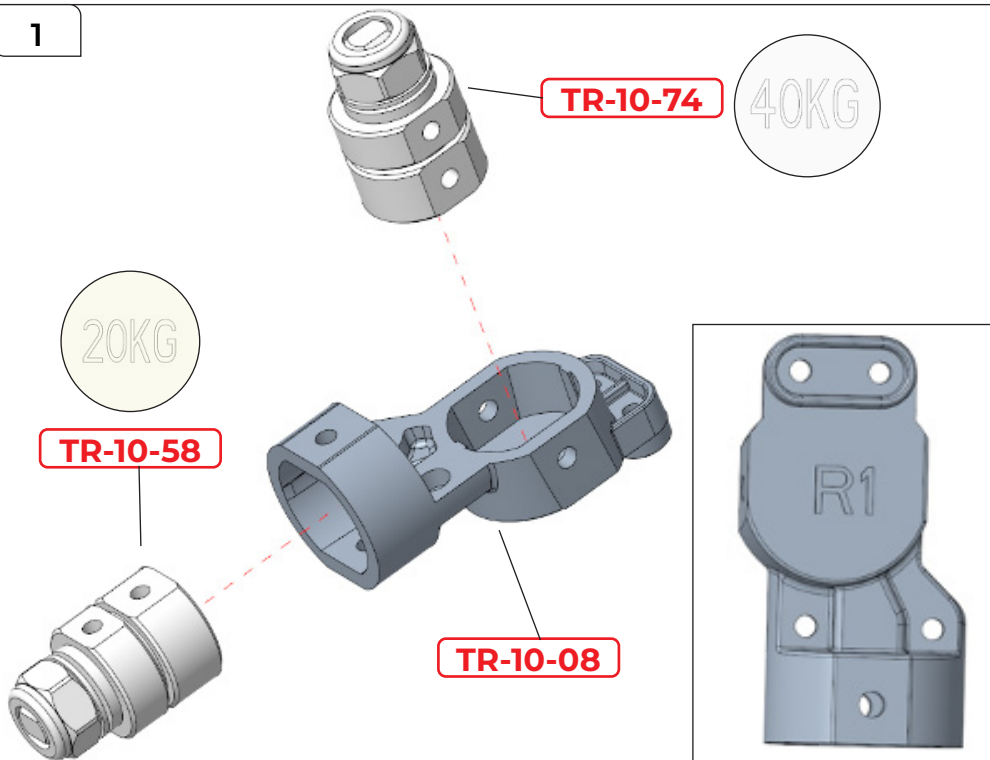

STEP 1

You'll now follow similar steps to assemble the upper right leg.

Start by correctly identifying the parts, checking their torque values marked on the ends. Part TR-10-08 is marked 'R1'.

Hold TR-10-08 in the orientation shown and fit the widest end of parts 58 and 74 into the recesses.

Assembling the Upper Right Leg

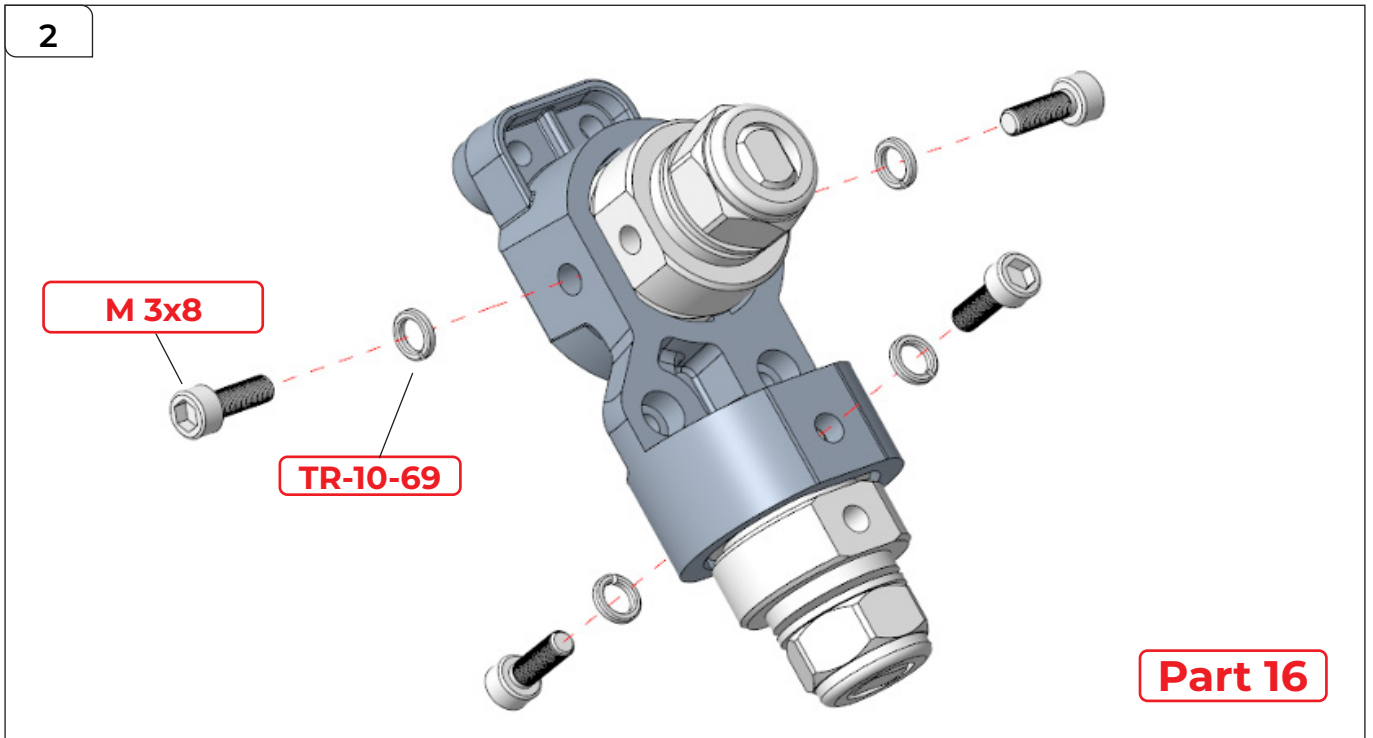

STEP 2

Secure the parts together using 4x TR-10-69 washers fitted onto 4x M 3x8 mm screws. This now forms assembly Part 16.

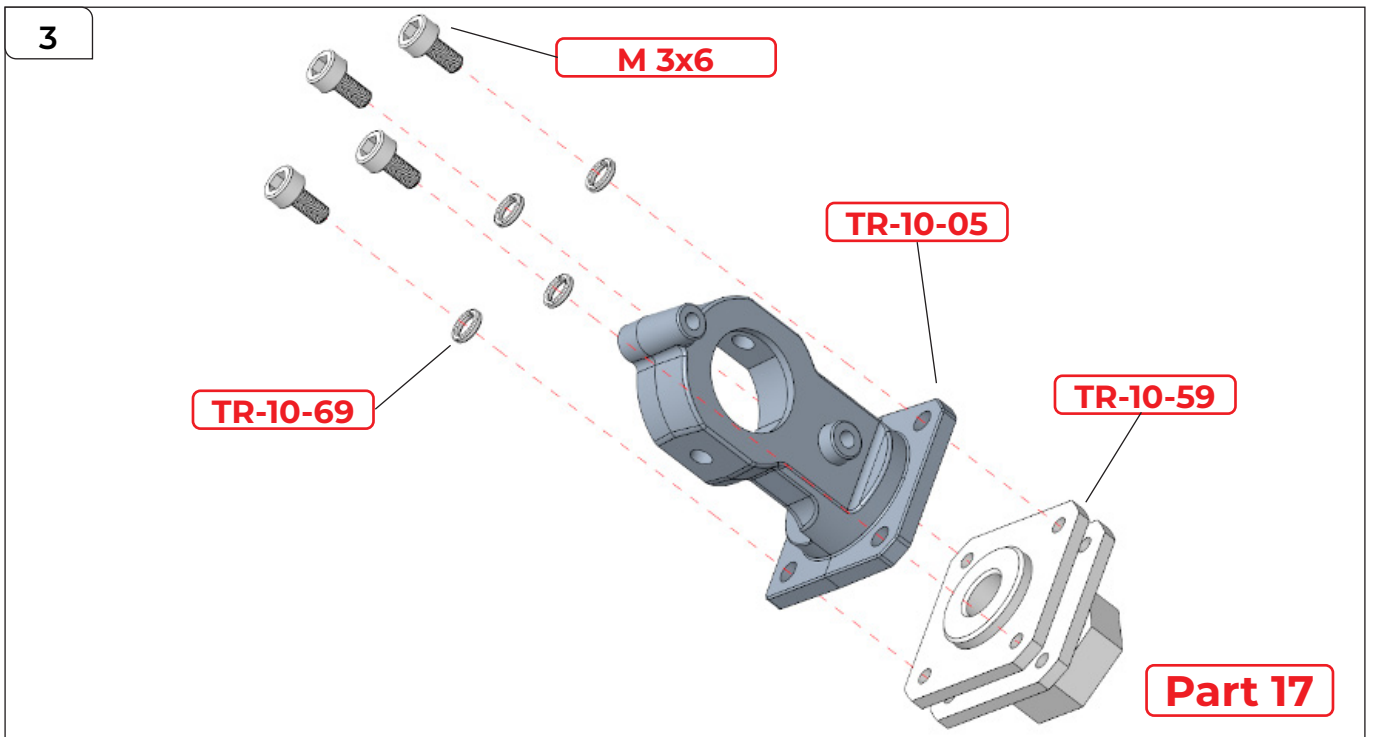

STEP 3

Attach TR-10-05 to TR-10-59 and secure them using 4 x TR-10-69 washers fitted to 4x M 3x6 mm screws. This now forms assembly Part 17.

Assembling the Upper Right Leg

4

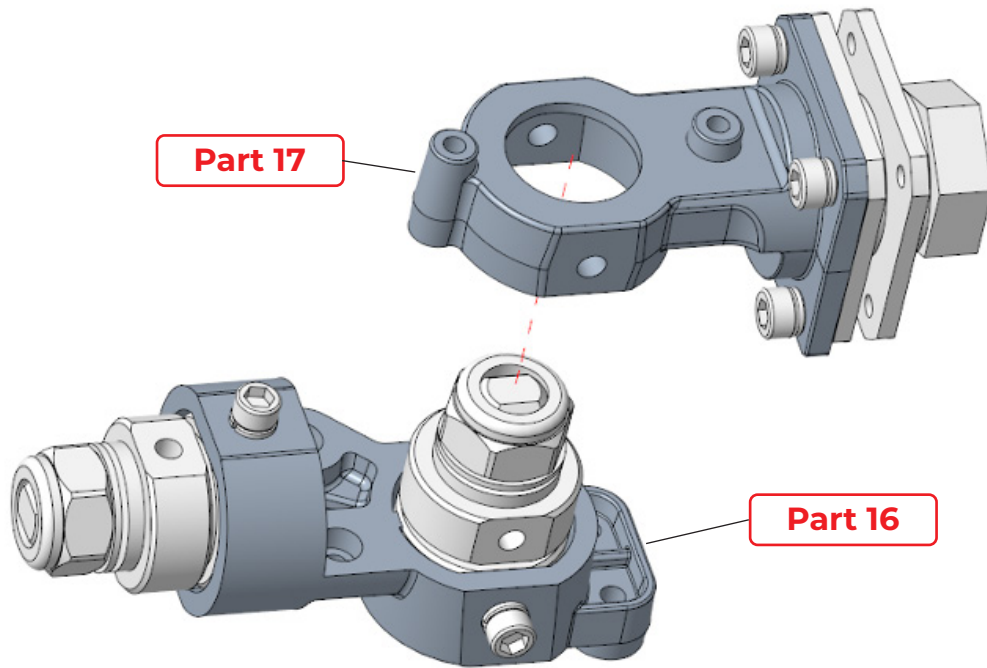

STEP 4

Fit assembly Part 17 to assembly Part 16 as shown.

5

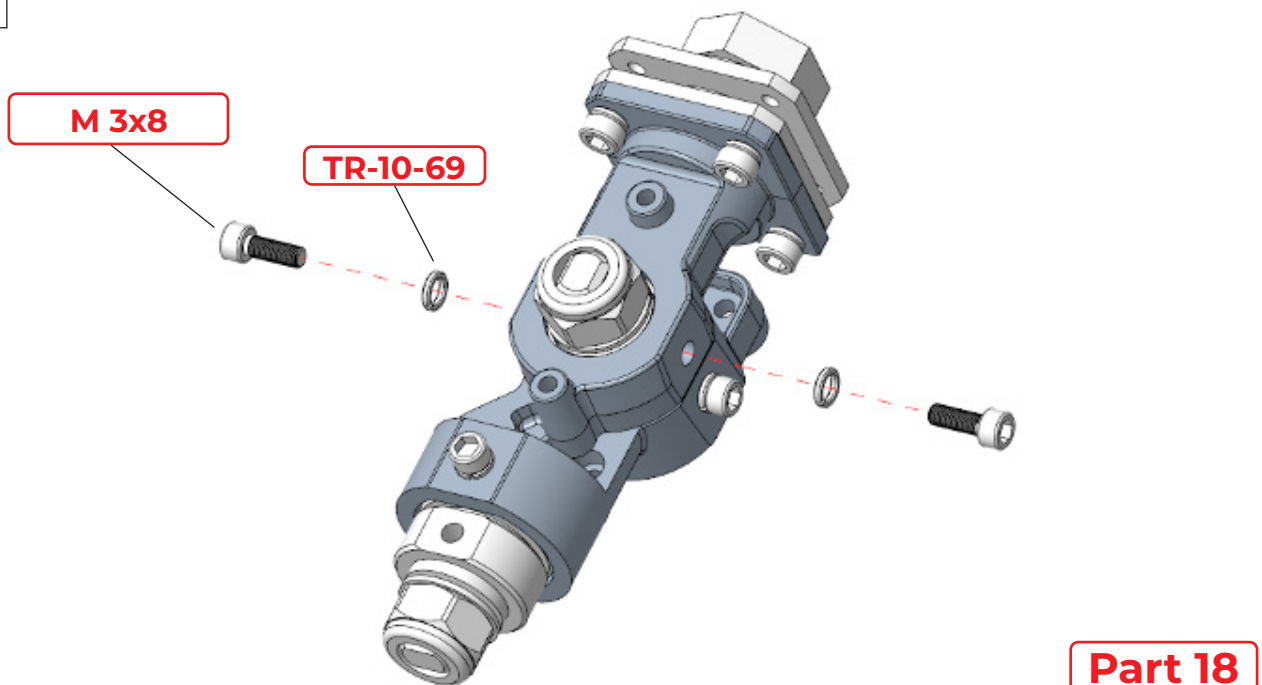

STEP 5

Secure the parts together using 2x TR-10-69 washers fitted to 2x M 3x8 mm screws. This now forms assembly part 18.

Assembling the Upper Right Leg

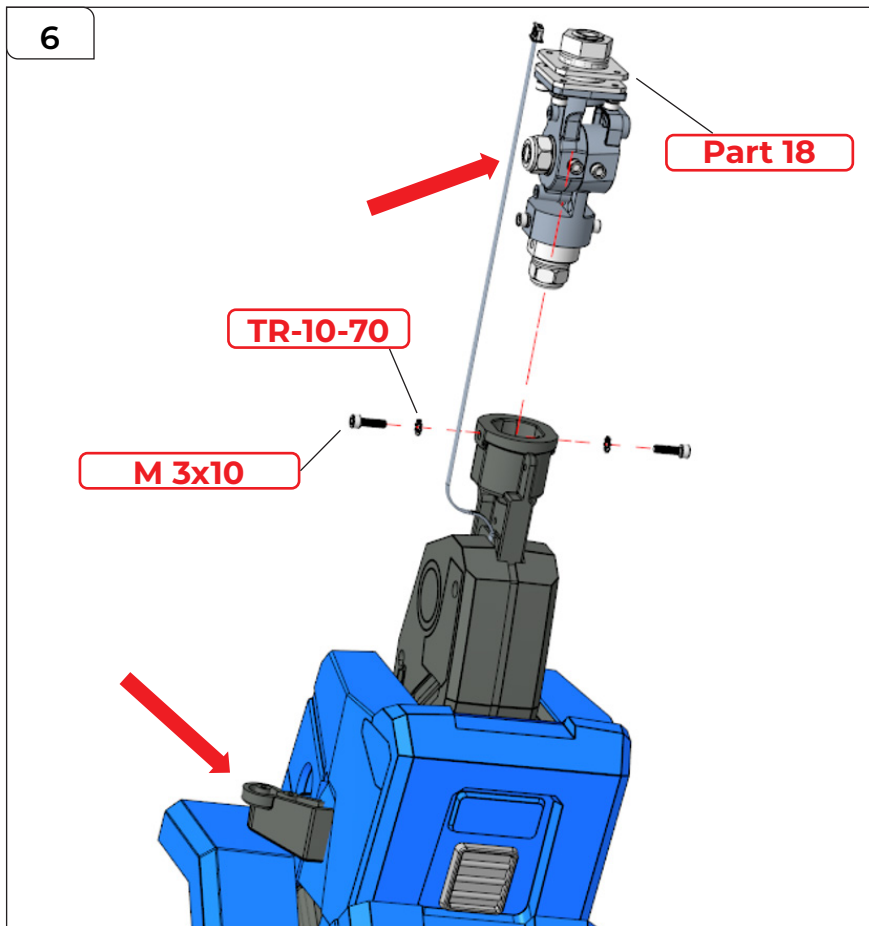

STEP 6

Take the lower right leg assembled in pack 9 and position assembly Part 18 into the opening at the top of the leg as shown. Pay close attention to the direction, ensuring the parts indicated with an arrow are facing the same side. Secure the parts together using 2x TR-10-70 washers fitted to 2x M 3x10 mm screws.

Assembling the Upper Right Leg

7

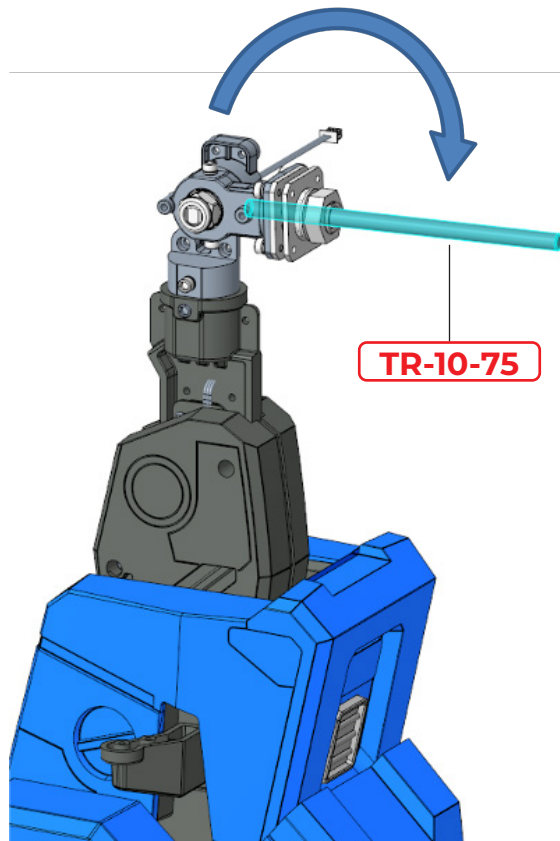

7b

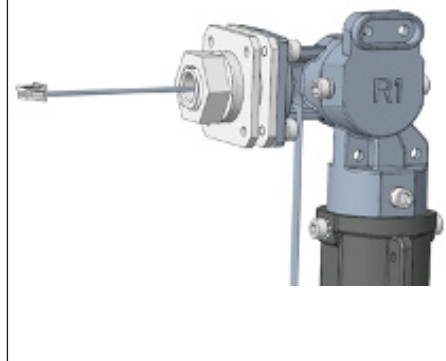

STEP 7

First, use the metal rod (TR-10-75) to turn the joint through 90 degrees downwards.

Then, keeping the rod in place, turn the joint through 90 degrees in a horizontal motion (7a).

Now feed the wire through the opening in Part 18 as shown in 7b above.

7a

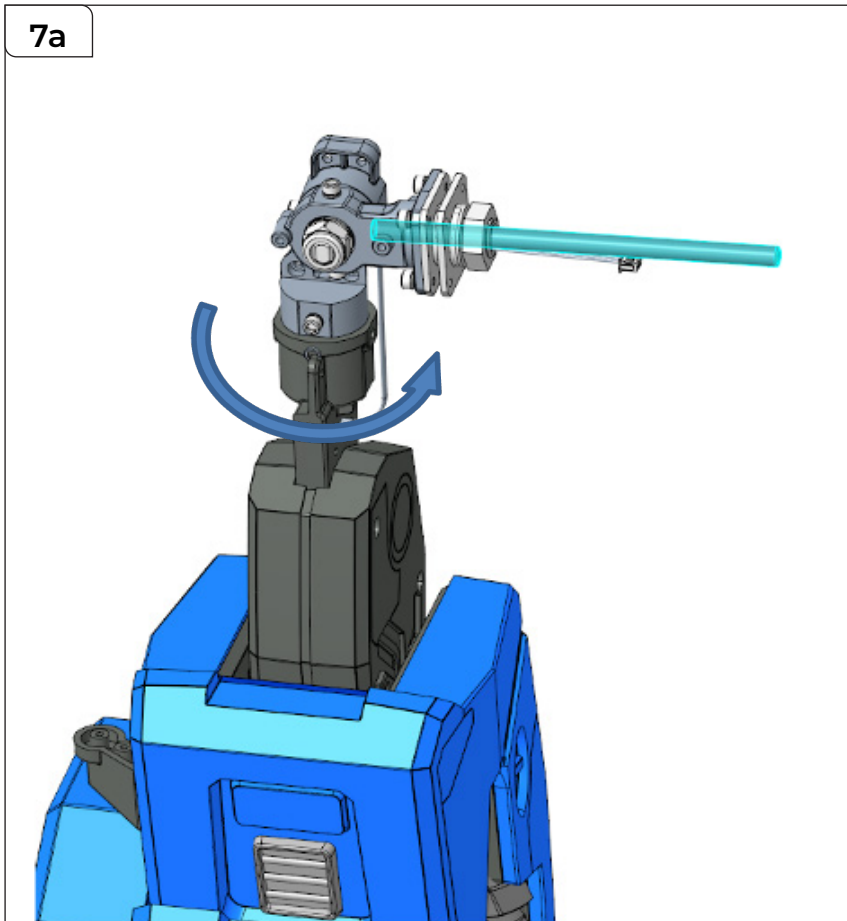

Assembling the Upper Right Leg

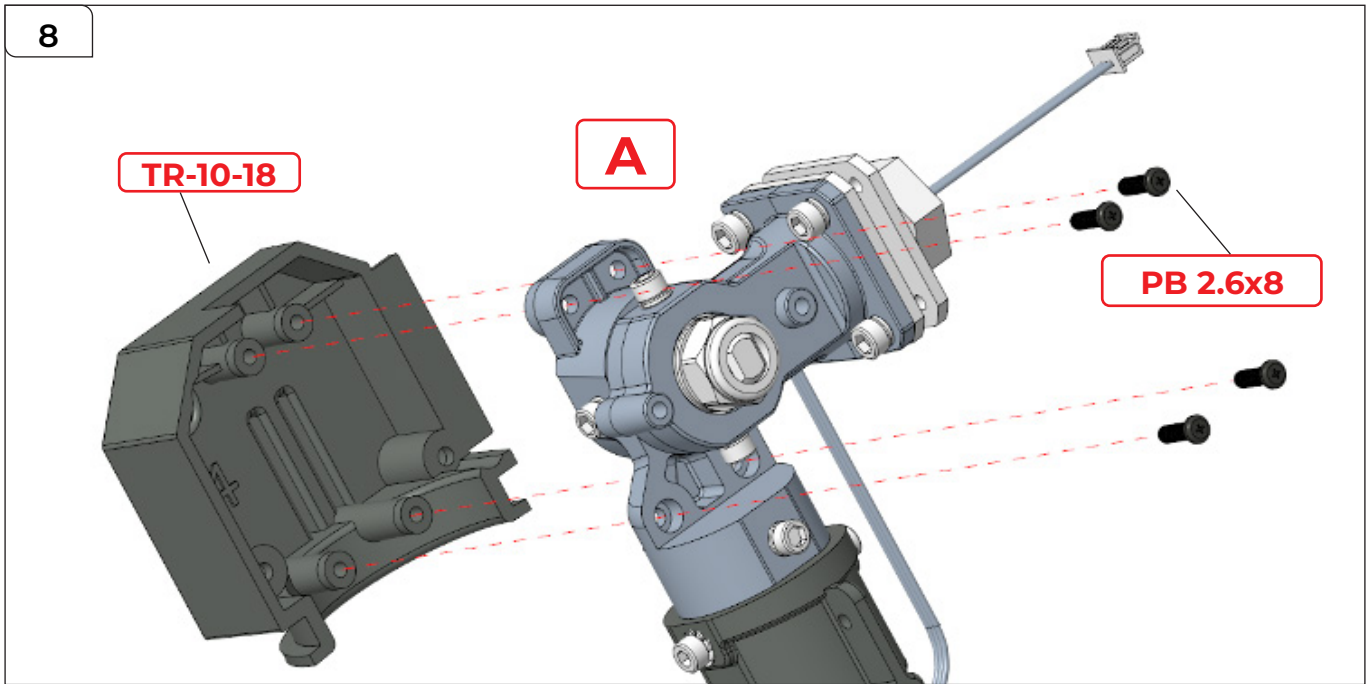

STEP 8

Fit part TR-10-18 to the joint (A) as shown, securing it in place with 4x PB 2.6x8 mm screws.

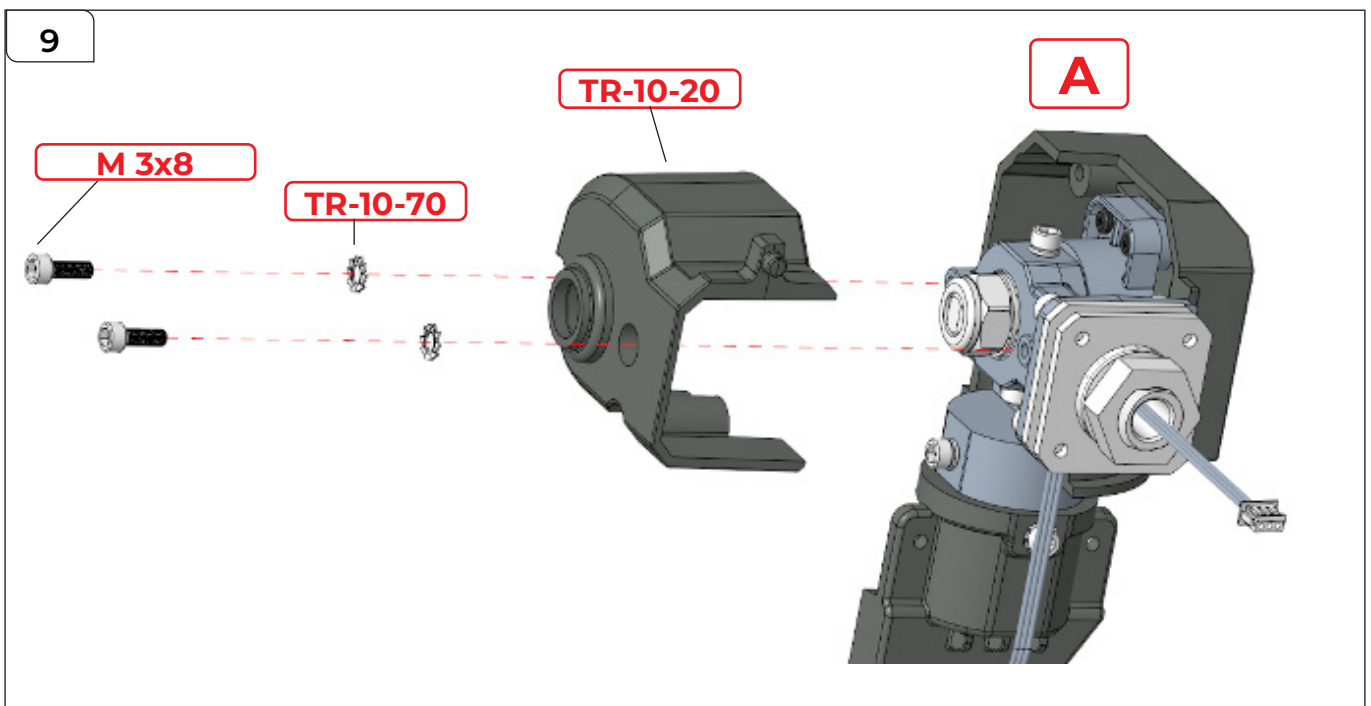

STEP 9

Fit part TR-10-20 to the opposite side of the joint (A), securing it in place with 2x TR-10-70 washers fitted onto 2x M 3x8 screws.

Assembling the Upper Right Leg

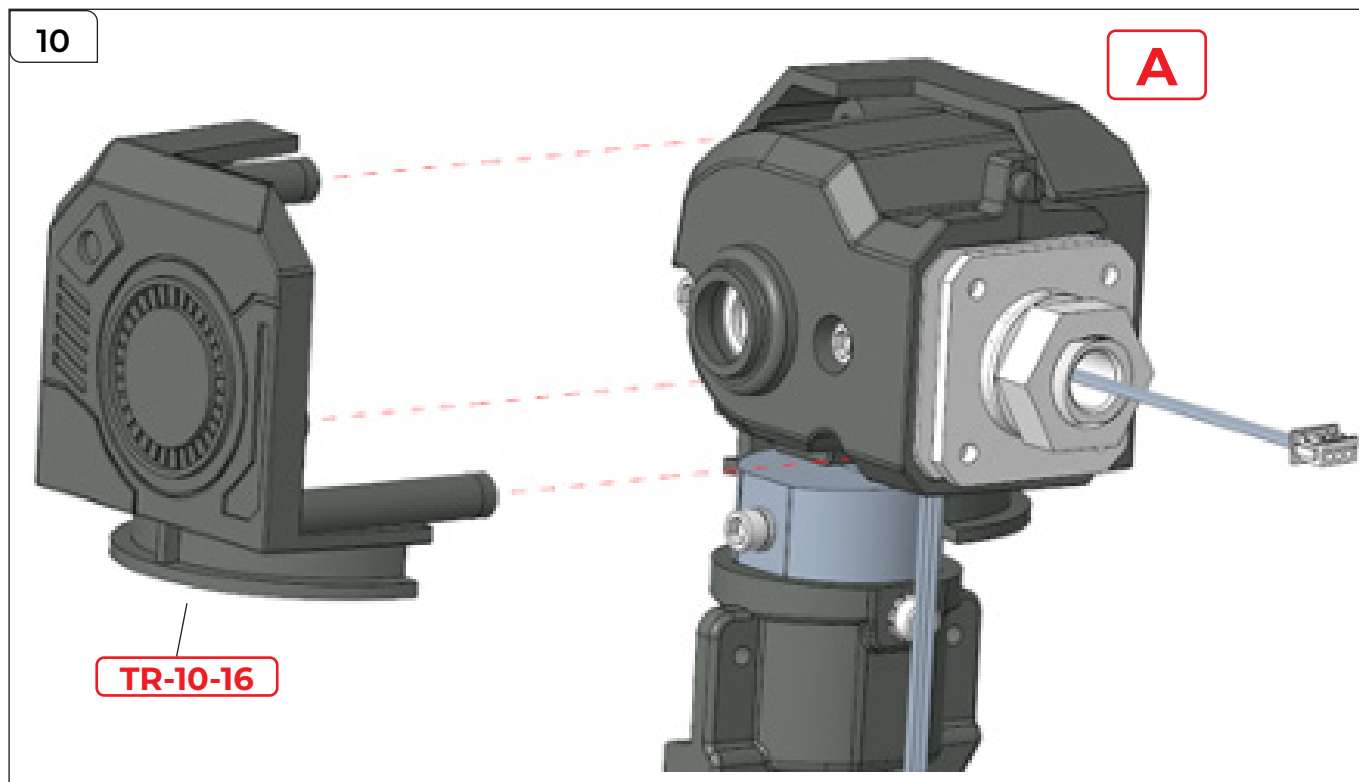

STEP 10

Fit TR-10-16 over the top.

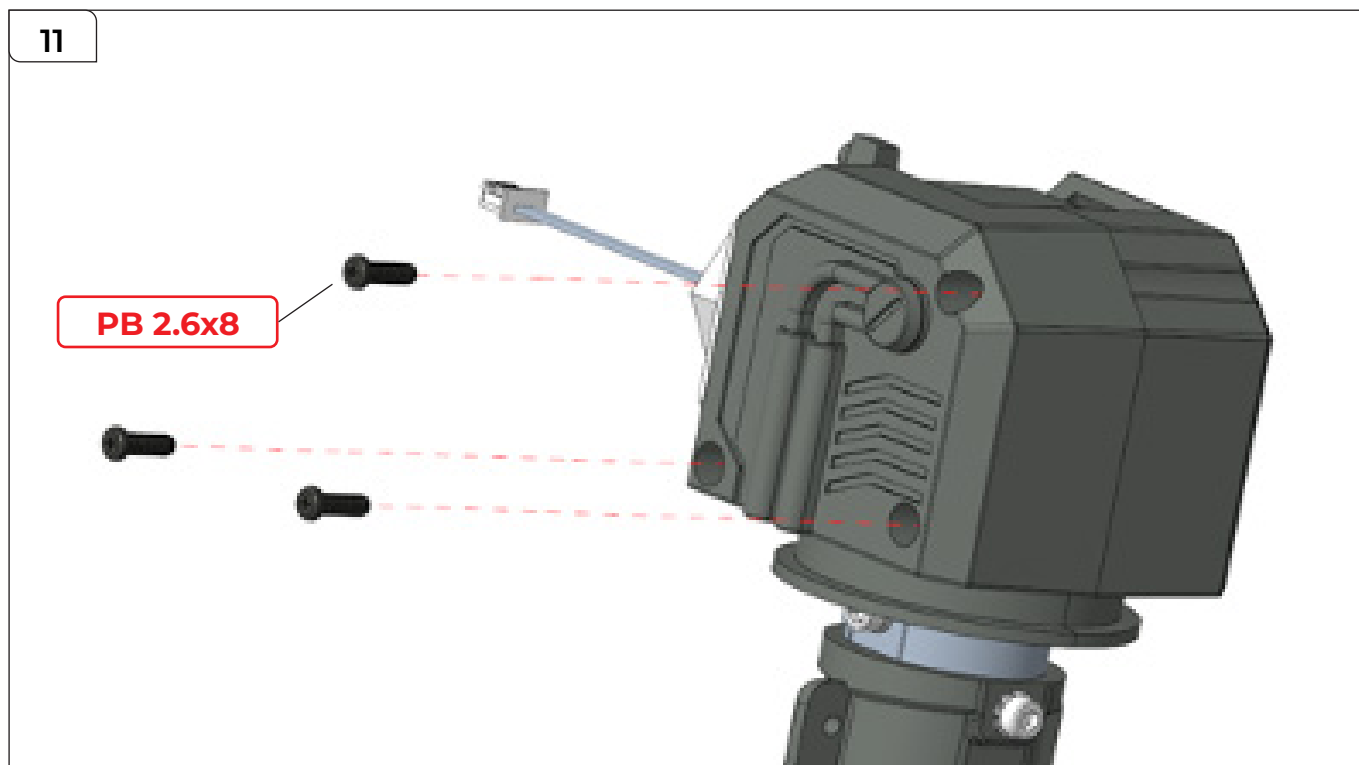

STEP 11

Secure it using 3x PB 2.6x8 mm screws.

Assembling the Upper Right Leg

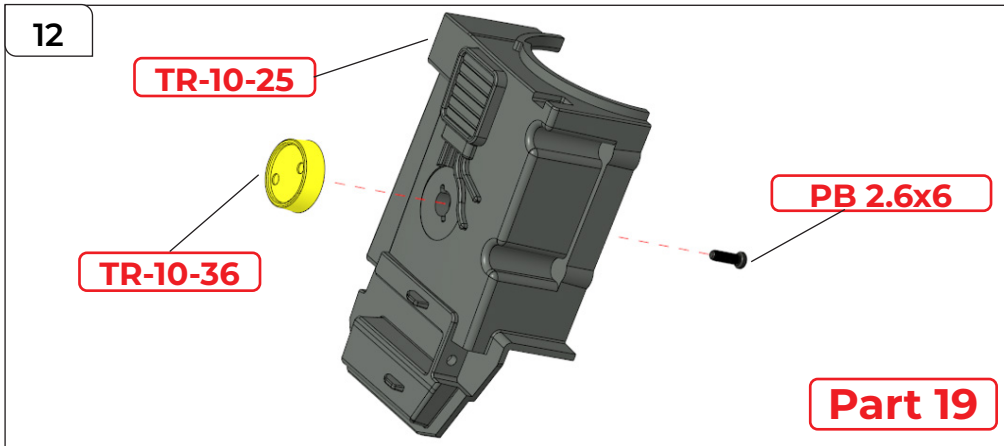

STEP 12

Take part TR-10-25 and fix part TR-10-36 into the circular recess as shown. Secure it from the reverse side with a PB 2.6x6 mm screw. This now forms Part 19.

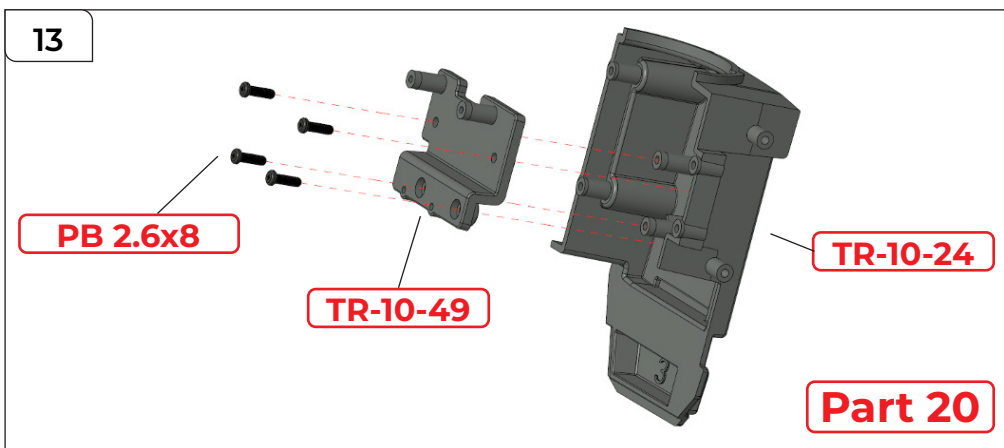

STEP 13

Take TR-10-24 and TR-10-49 and attach them together as shown. Secure them using 4x PB 2.6x8 mm screws. This now forms Part 20.

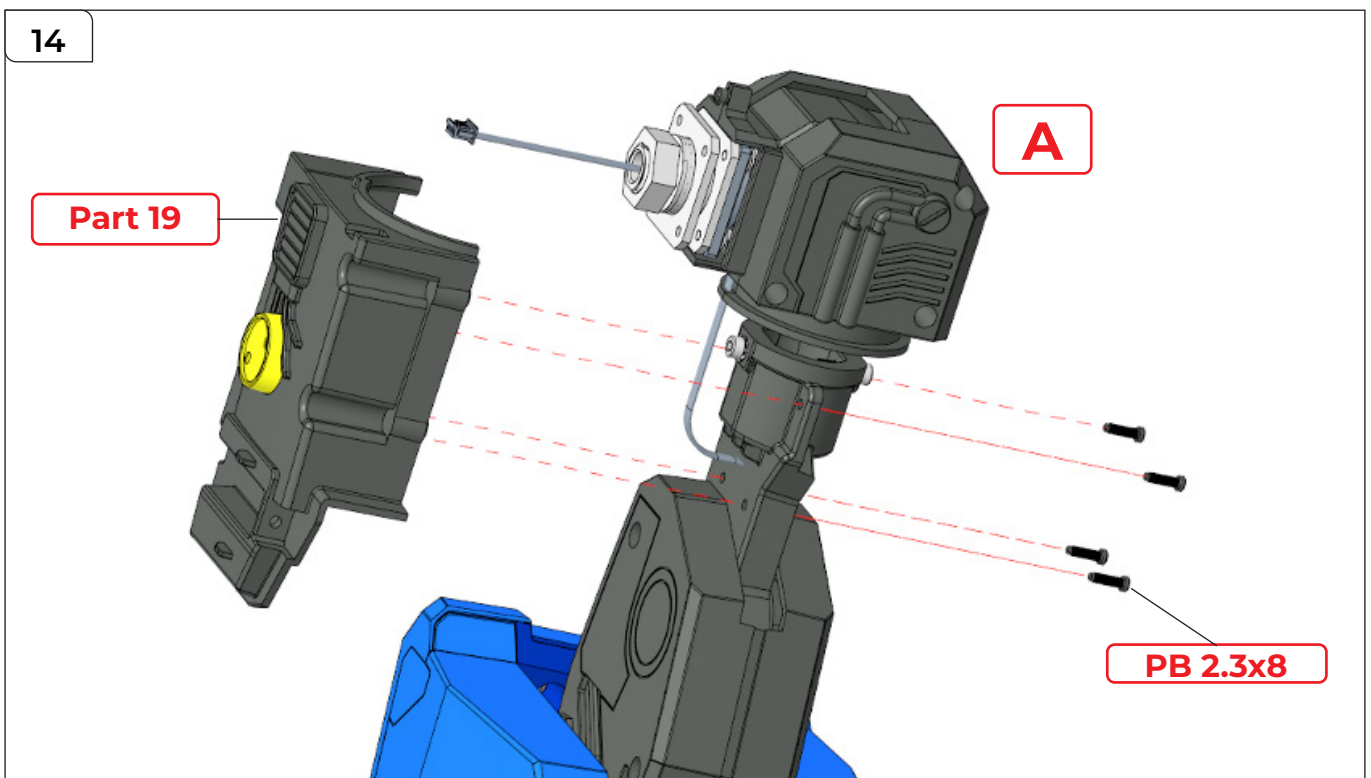

STEP 14

Fit Part 19 to the top of the leg (A), securing it using 4x PB 2.3x8 mm screws.

Assembling the Upper Right Leg

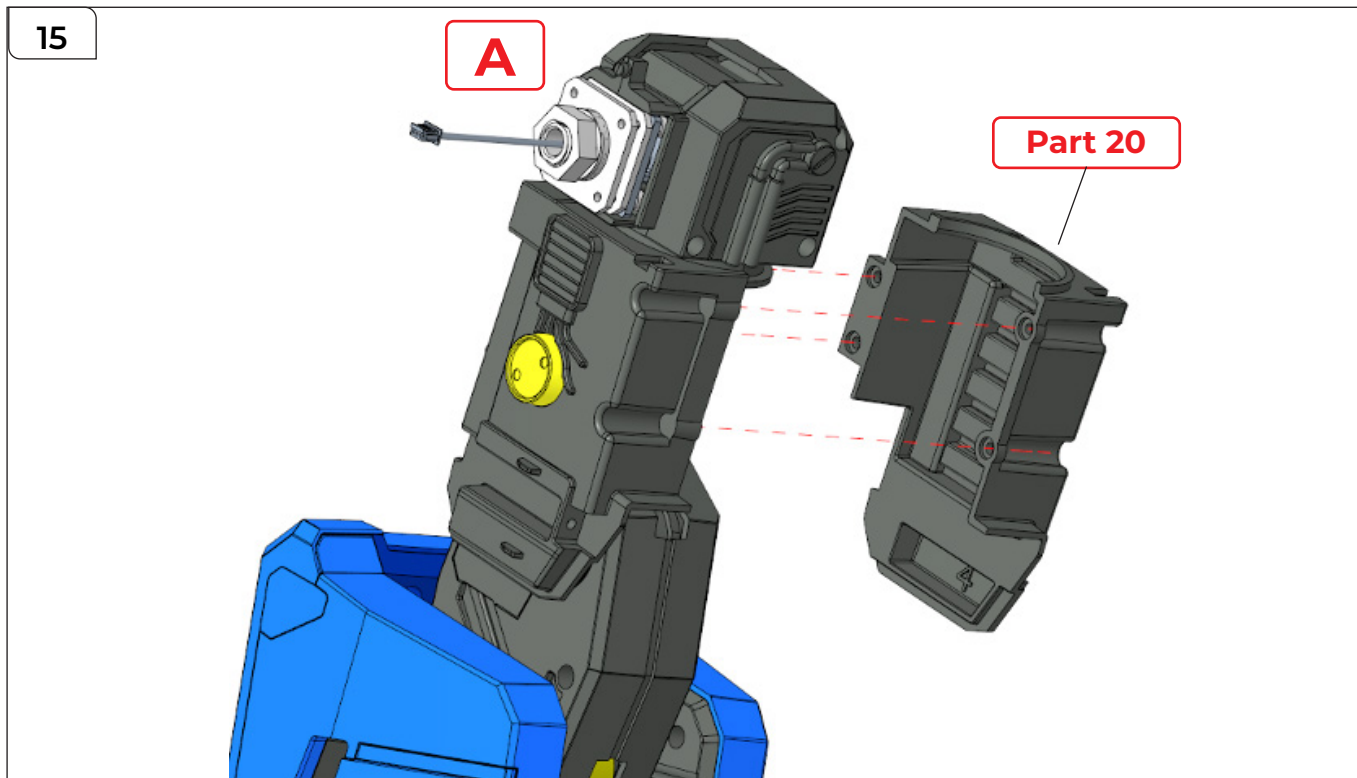

STEP 15

Fit assembly Part 20 to the opposite side.

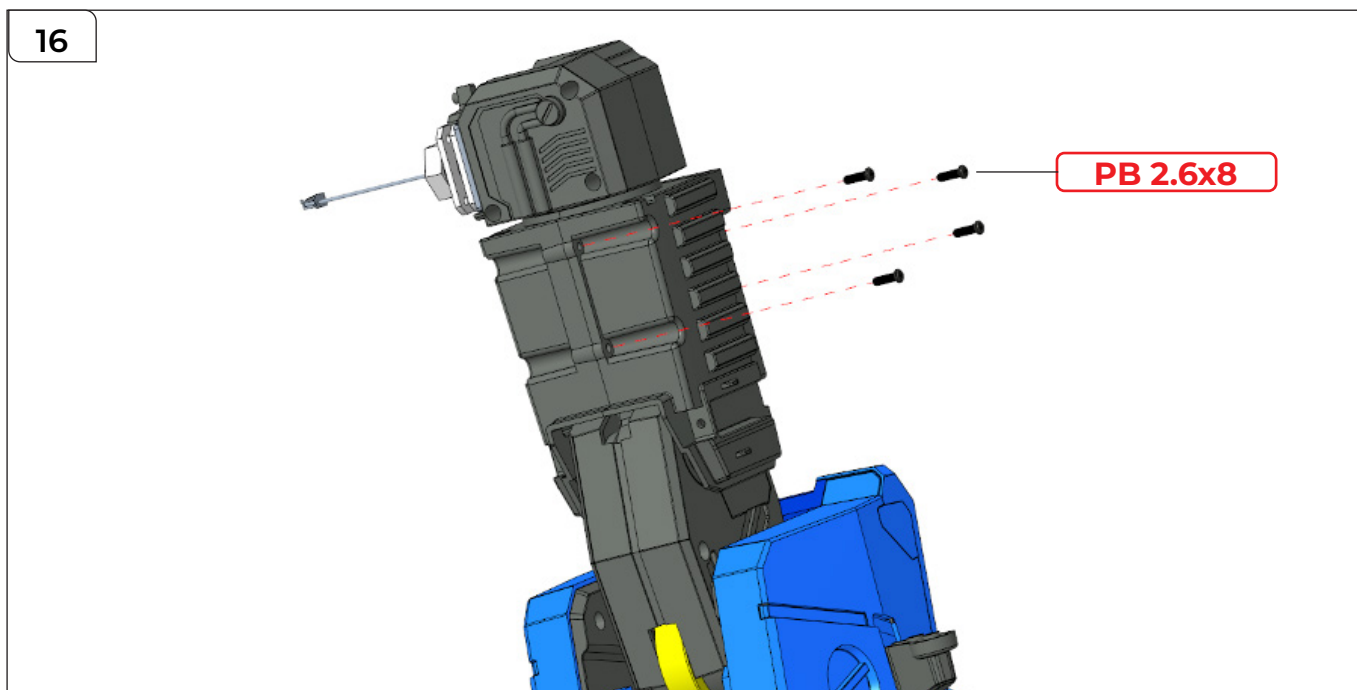

STEP 16

Secure in place from the opposite side using 4x PB 2.6x8 mm screws.

Assembling the Upper Right Leg

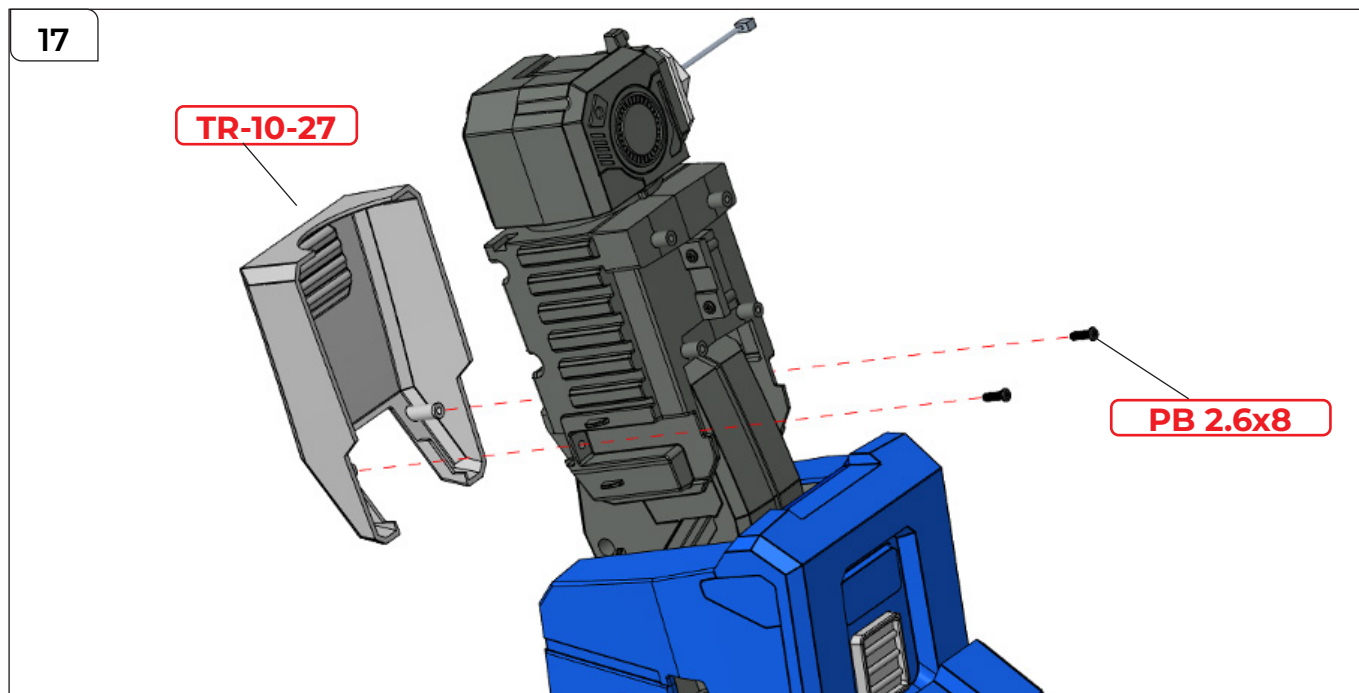

STEP 17

Attach TR-10-27 in the orientation shown and secure using 2x PB 2.6x8 mm screws.

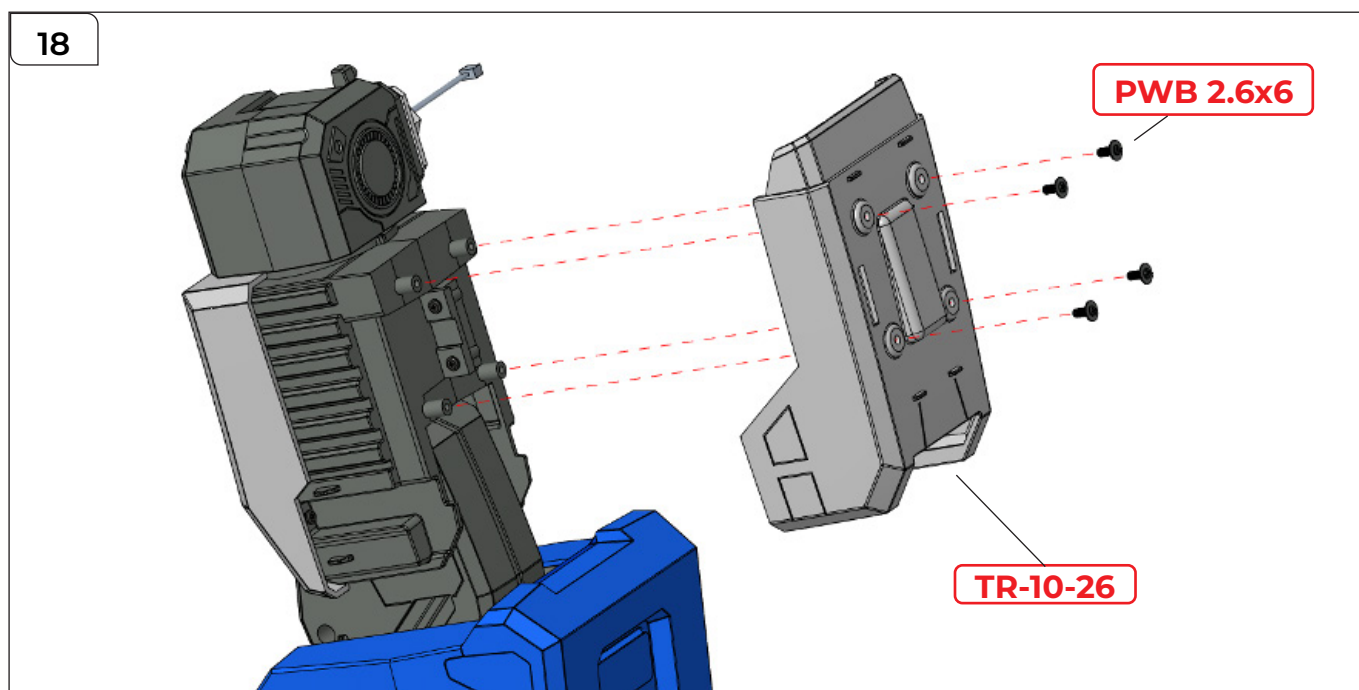

STEP 18

Attach TR-10-26 to the opposite side and secure using 4x PWB 2.6x6 mm screws.

Assembling the Upper Right Leg

19

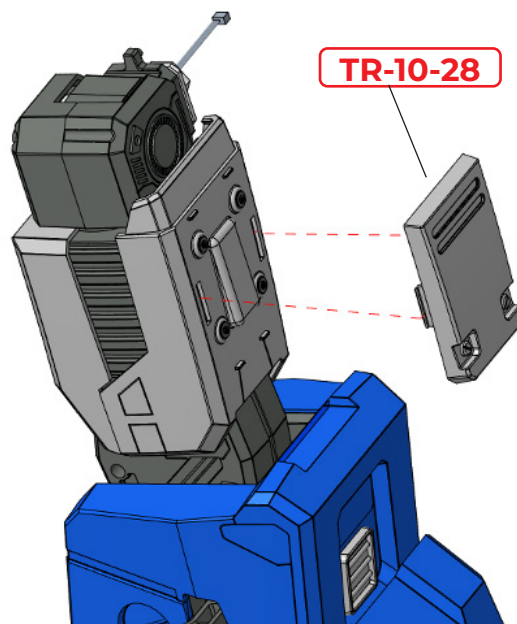

STEP 19

Push TR-10-28 on top, covering the screws.

20

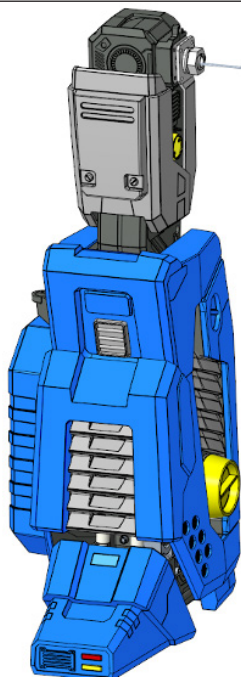

Part 21

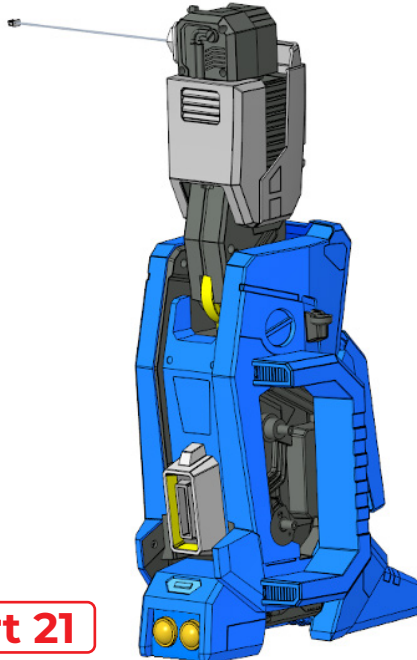

Part 21

STEP 20

This now forms Part 21.

Assembling the Hips and Attaching Them to the Legs

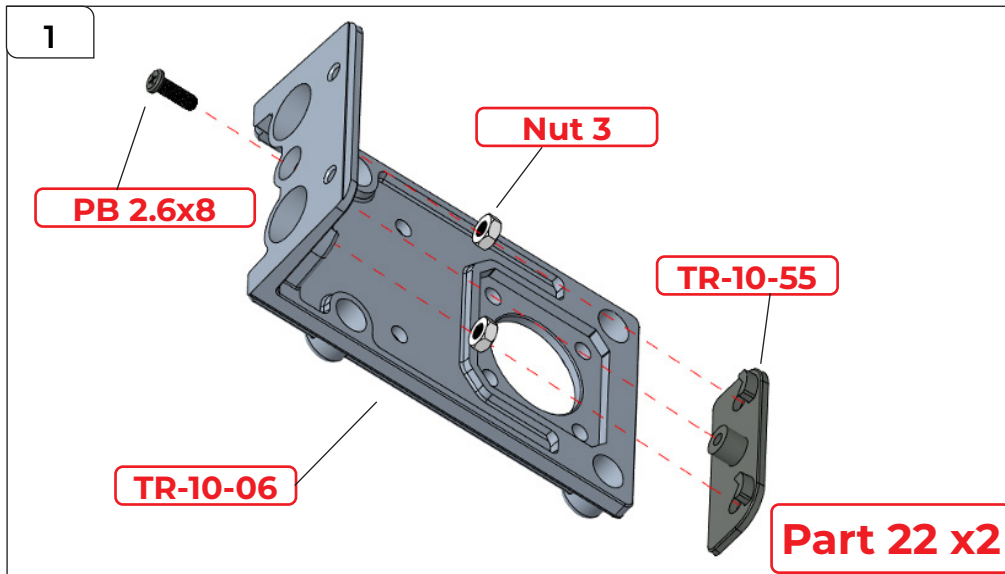

STEP 1

Place 2x Nut 3 onto TR-10-55, then attach it to TR-10-06. Secure with 1x PB 2.6x8 mm screw.

Repeat to make 2x assembly Part 22.

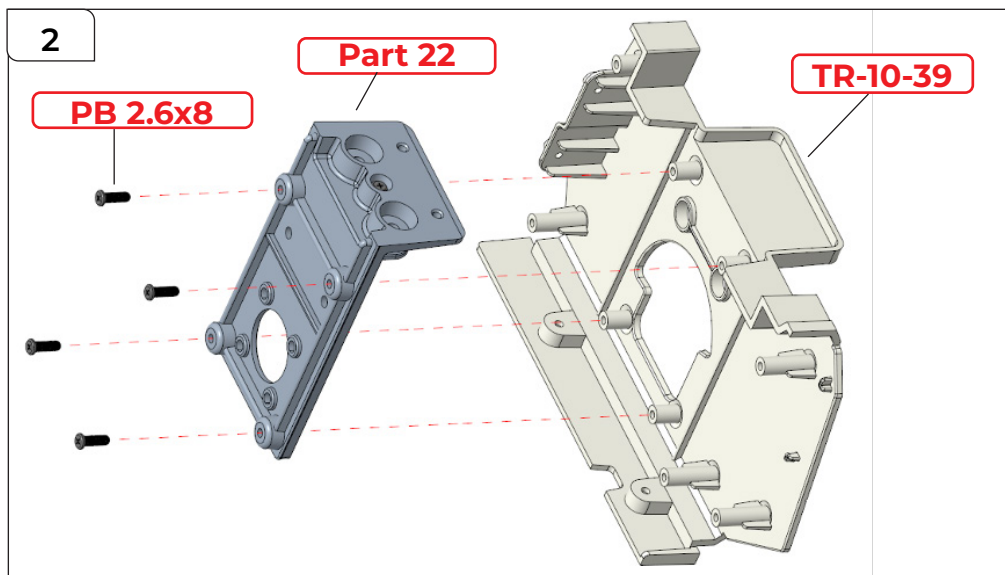

STEP 2

Attach 1x Part 22 to TR-10-39, securing them together using 4x PB2.6x8 mm screws.

Note: Take care when fixing these parts together. Too much force may cause them to crack.

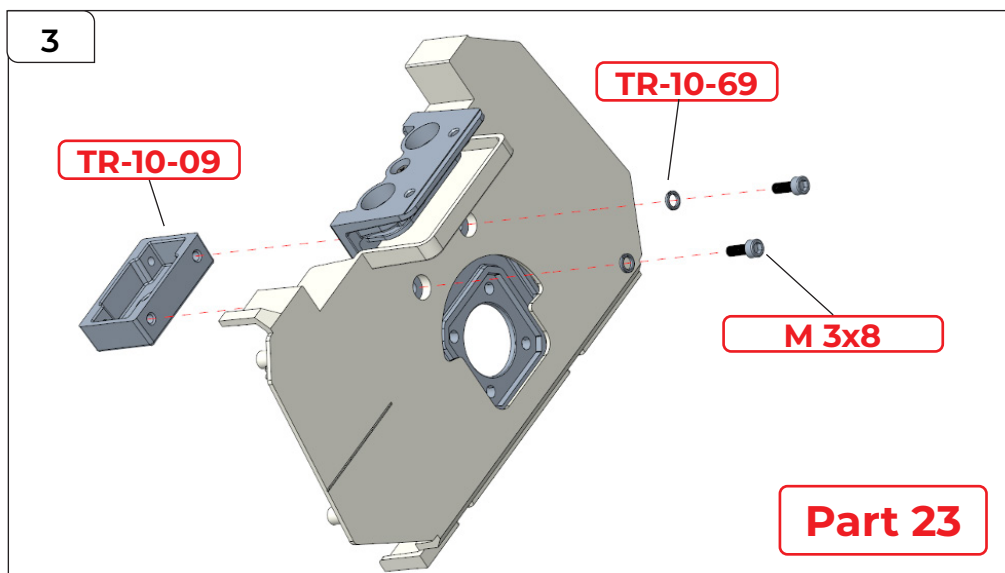

STEP 3

Attach TR-10-09 on top. Thread 2x TR-10-69 washers onto 2x M 3x8 mm screws, using them to fix the parts together from the reverse side. This now forms Part 23.

Assembling the Hips and Attaching Them to the Legs

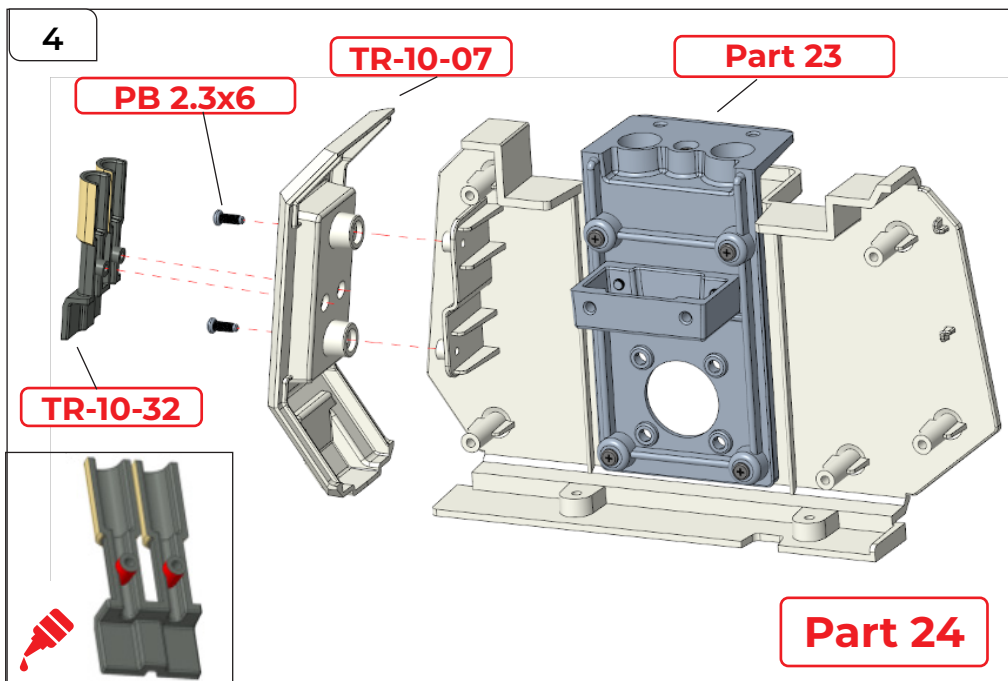

STEP 4

Attach TR-10-07 to Part 23 as shown. Secure it in place using 2x PB 2.3x6 mm screws.

Take part TR-10-32, apply a little glue as shown before fixing it over the screws.

This now forms Part 24.

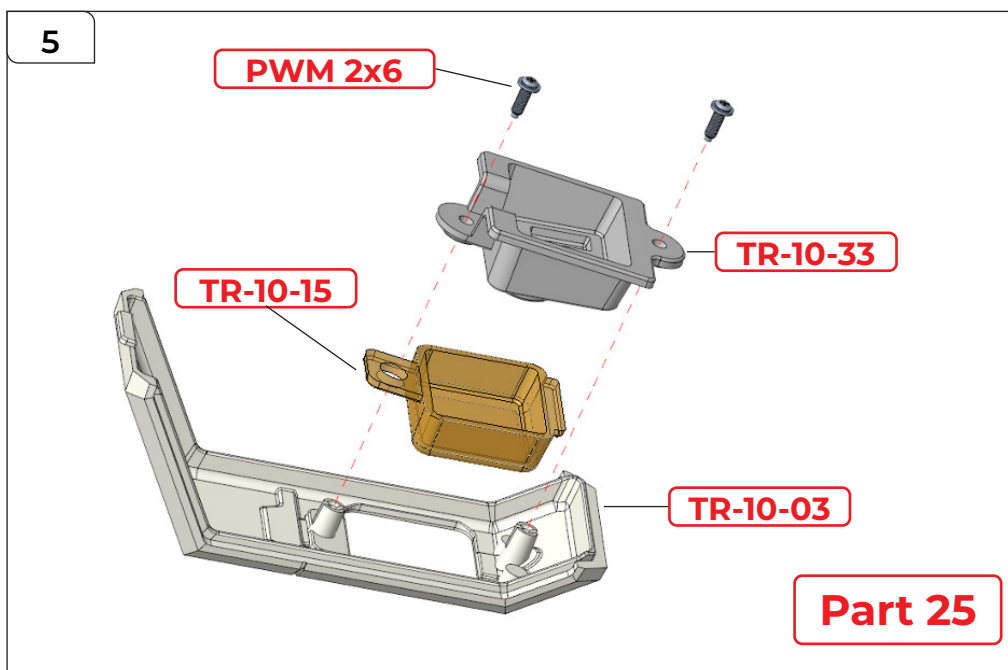

STEP 5

Place TR-10-15 into the recess in TR-10-03. Place TR-10-33 on top and secure everything together using 2x PWM 2x6 mm screws.

This now forms Part 25.

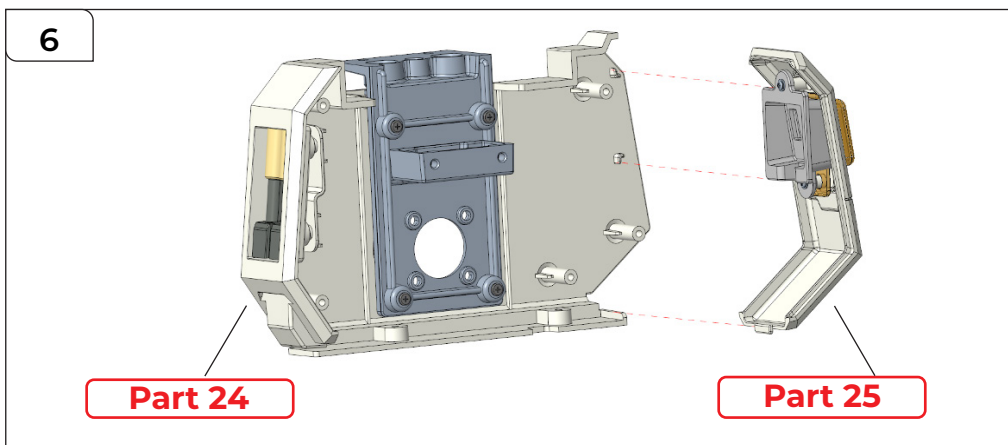

STEP 6

Attach Part 25 to part 24.

Assembling the Hips and Attaching Them to the Legs

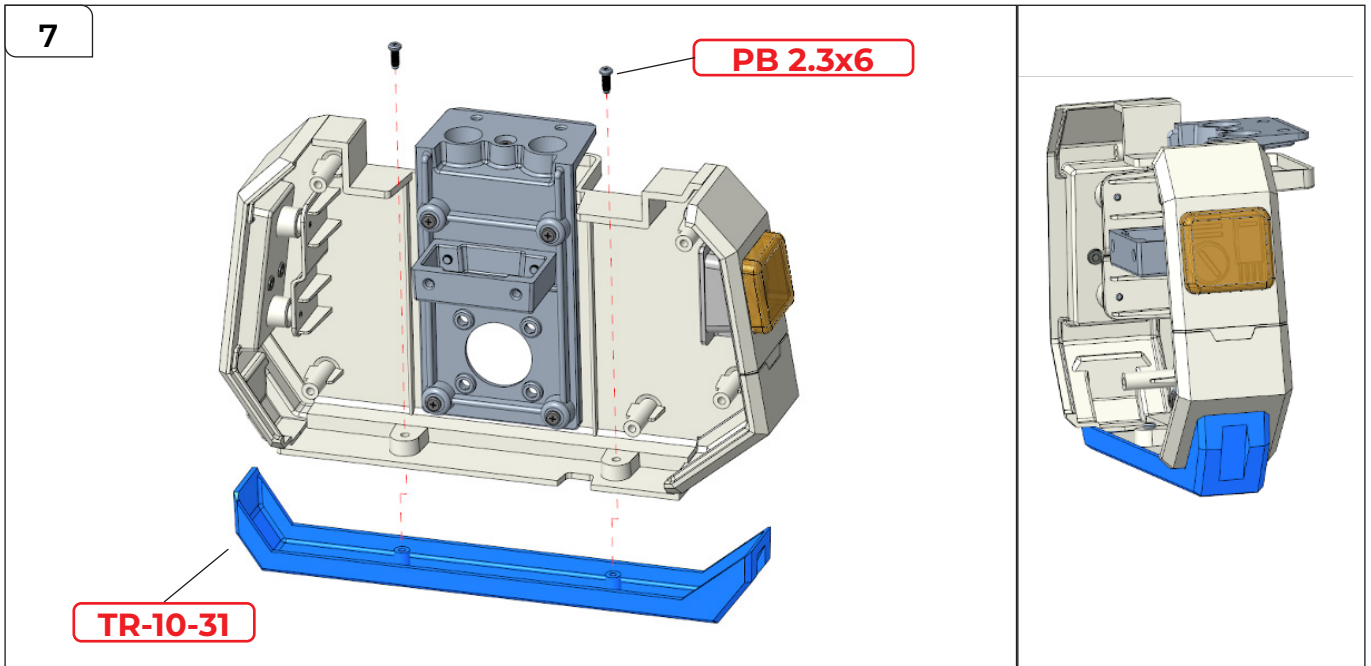

STEP 7

Attach TR-10-31 to the assembly and fix in place using 2x PB 2.3x6 mm screws. Pay close attention to the orientation of Tr-10-31, shown in 7a.

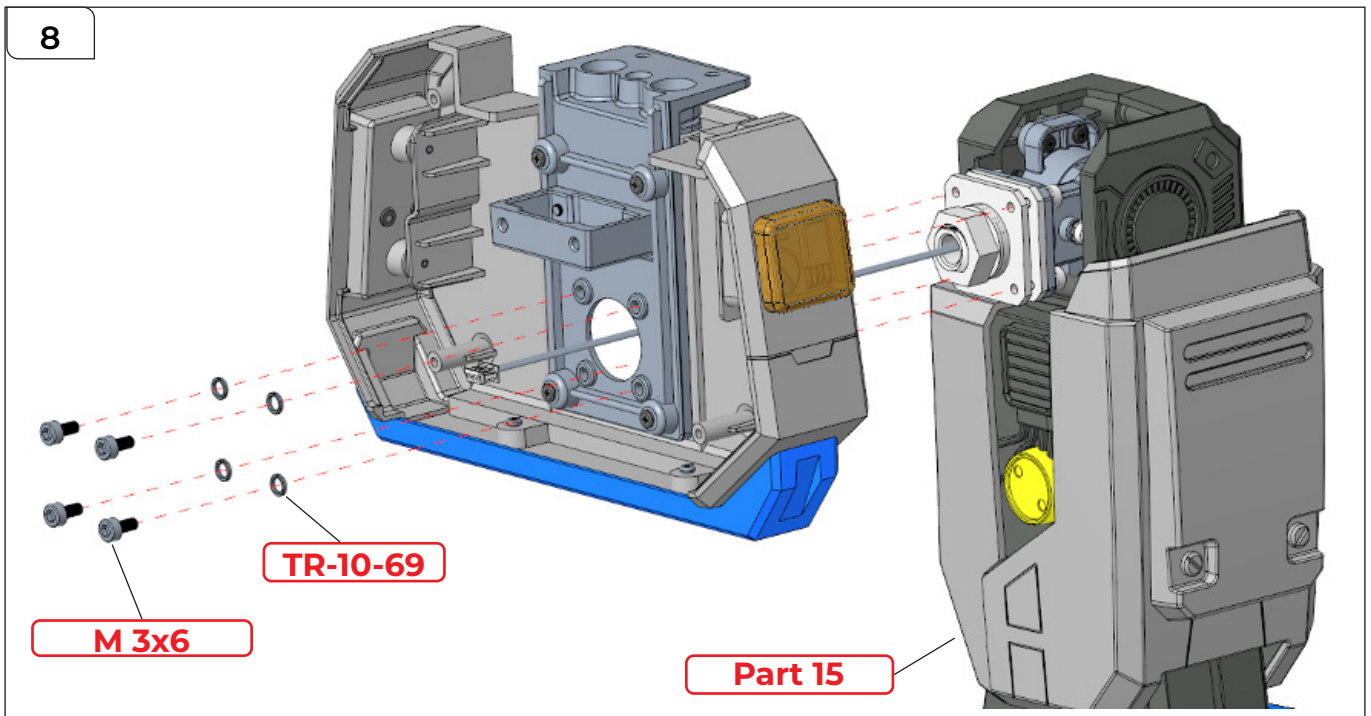

STEP 8

Attach the assembly to Part 15 - the Upper left leg. Thread 4x TR-10-69 washers onto 4x M 3x6 mm screws and secure the assembly in place.

Assembling the Hips and Attaching Them to the Legs

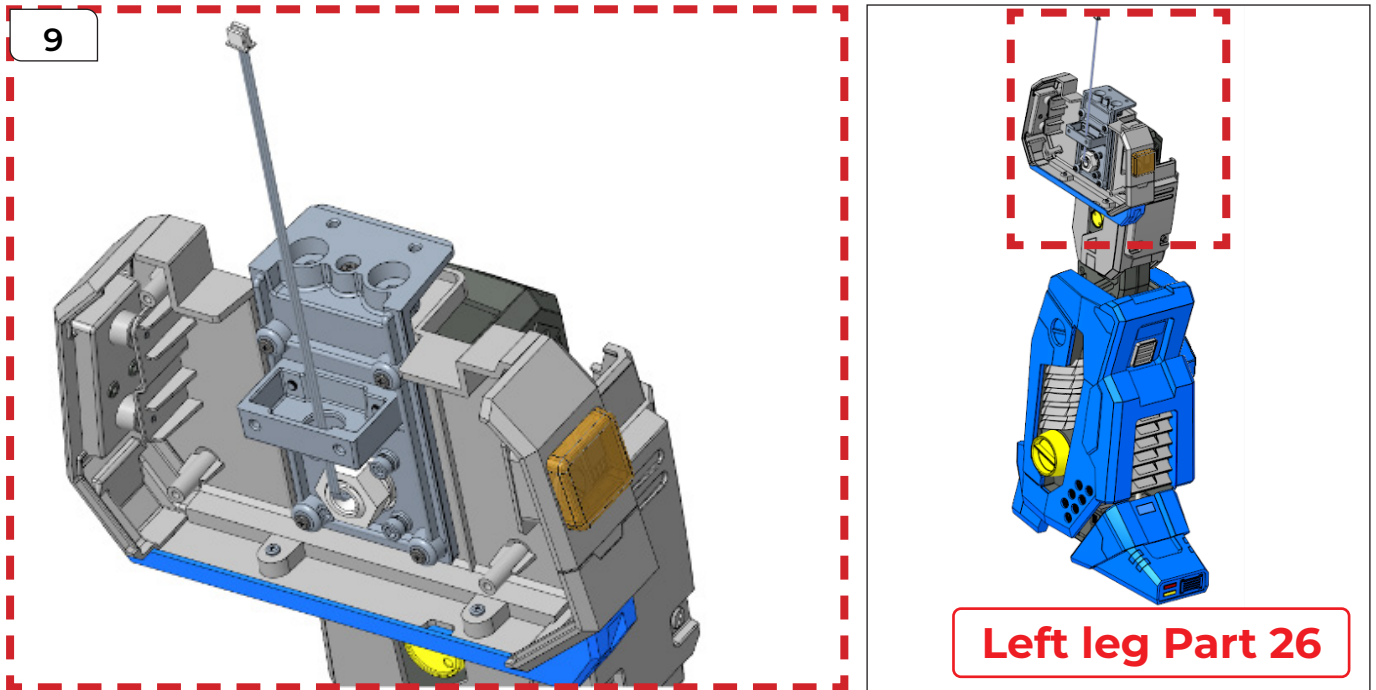

STEP 9

Route the wire through the opening in the leg as shown. This now forms Part 26.

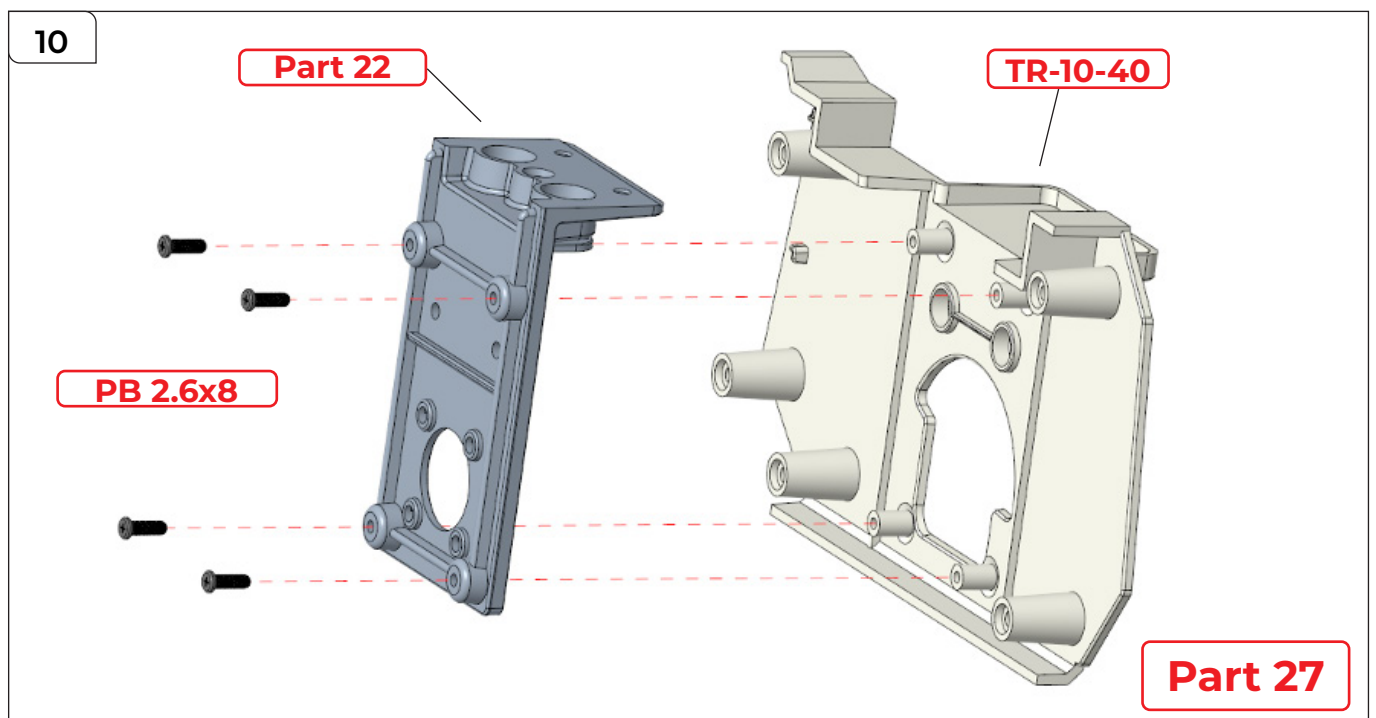

STEP 10

Attach the remaining Part 22 to TR-10-40, securing them together using 4x PB2.6x8 mm screws. This now forms Part 27.

Note: Take care when fixing these parts together. Too much force may cause them to crack.

Assembling the Hips and Attaching Them to the Legs

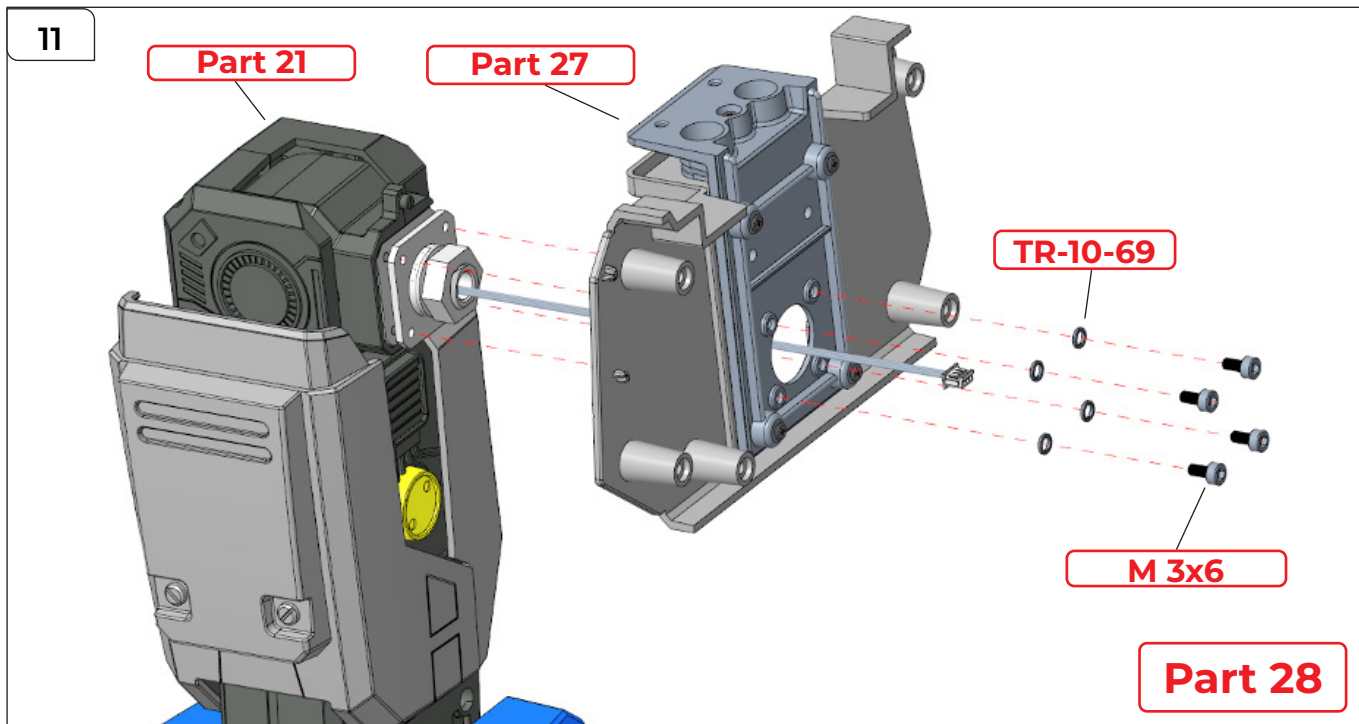

STEP 11

Attach Part 27 to part 21, threading the wire through the opening as shown. Thread 4x TR-10-69 washers onto 4x M 3x6 mm screws and secure everything together. This now forms Part 28.

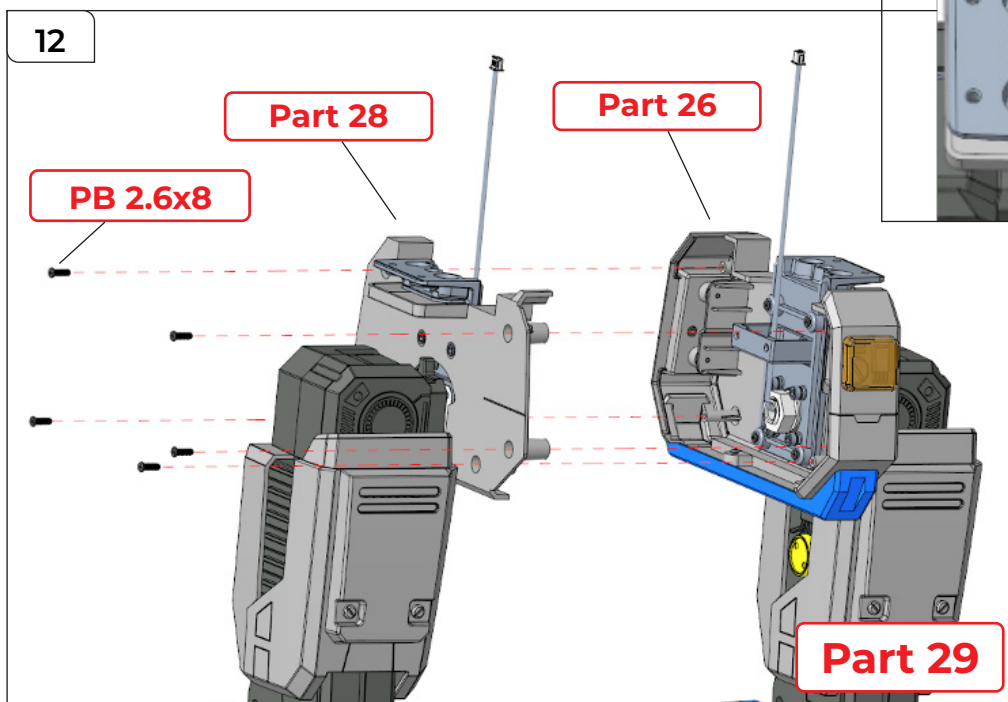
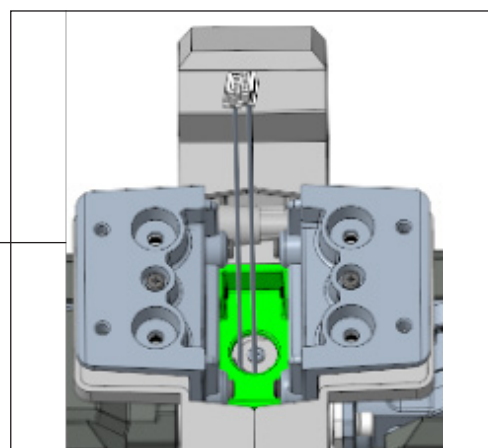

STEP 12

Fix the right leg (Part 28) to the left leg (Part 26) using 5x PB 2.6x8 mm screws. Both wires should be routed through the central opening as shown in 12a. This now forms Part 29.

Assembling the Hips and Attaching Them to the Legs

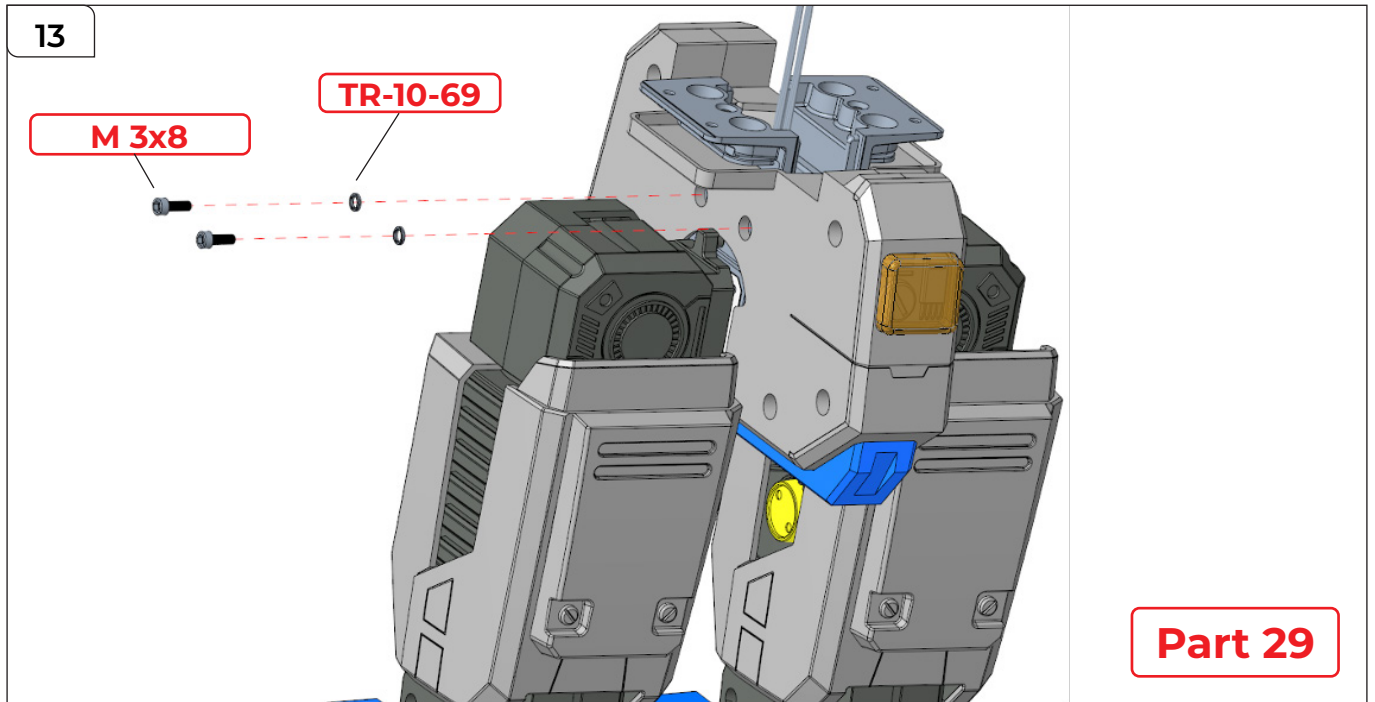

STEP 13

Thread 2x TR-10-69 washers onto 2x M 3x8 mm screws and drive the screws through the two holes as shown.

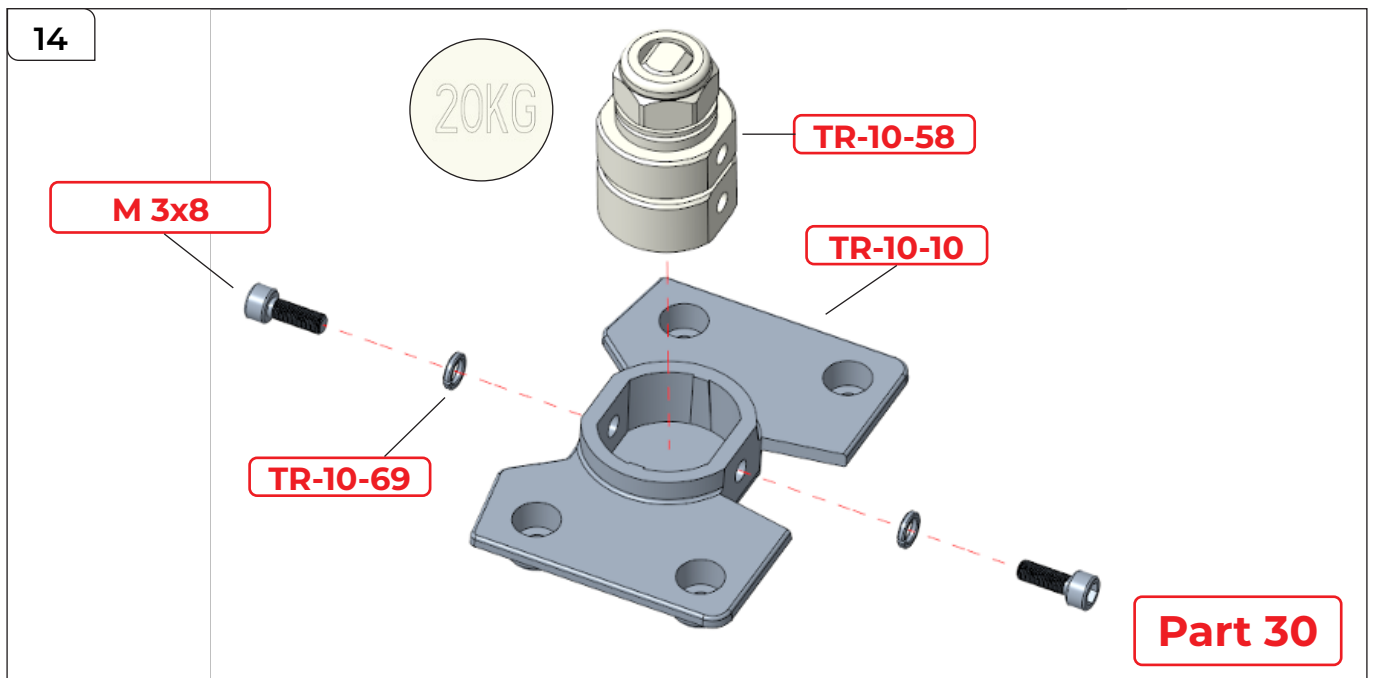

STEP 14

Take TR-10-58 and fit into the corresponding recess on TR-10-10 and. Secure the parts together using 2x TR-10-69 washers and 2x M 3x8 mm screws. This now forms Part 30.

Assembling the Hips and Attaching Them to the Legs

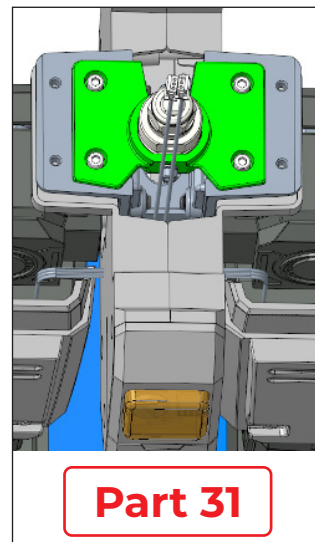
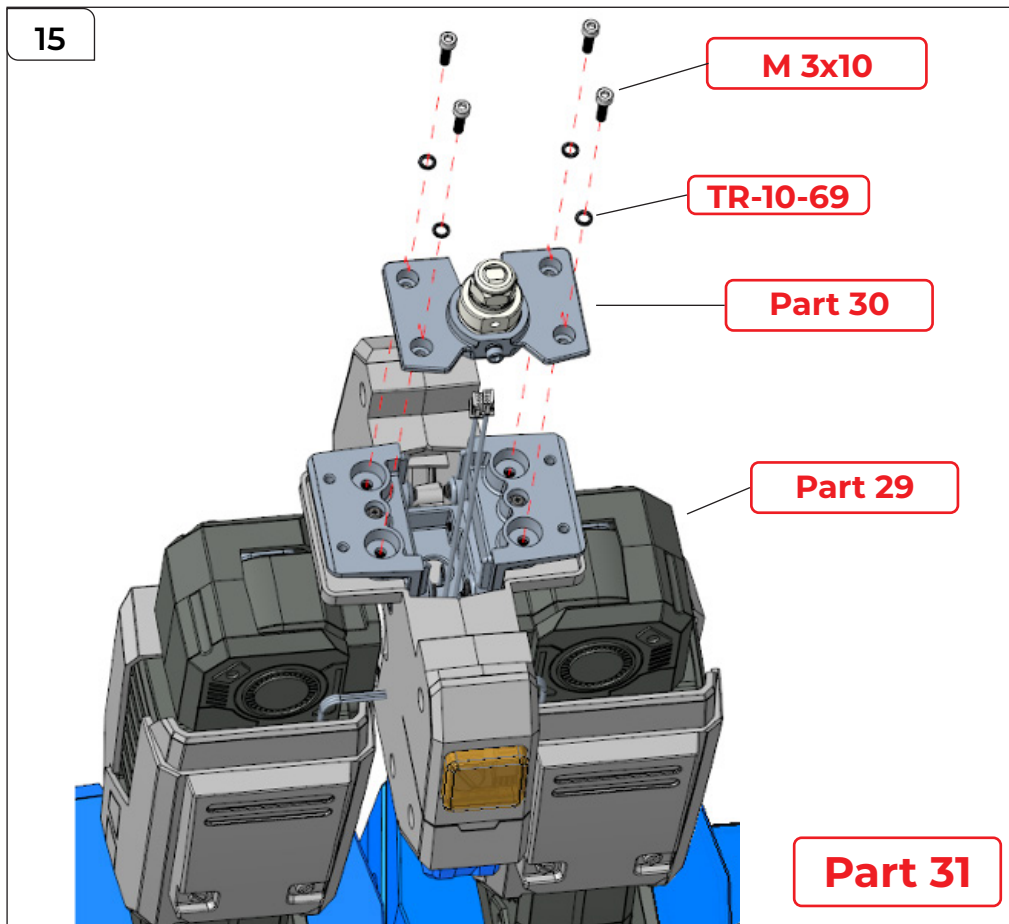

STEP 15

Attach part 30 to Part 29 and secure using 4x TR-10-69 washers and 4x M 3x10 mm screws. This now forms part 31. Ensure the wires are routed as shown in 15a.

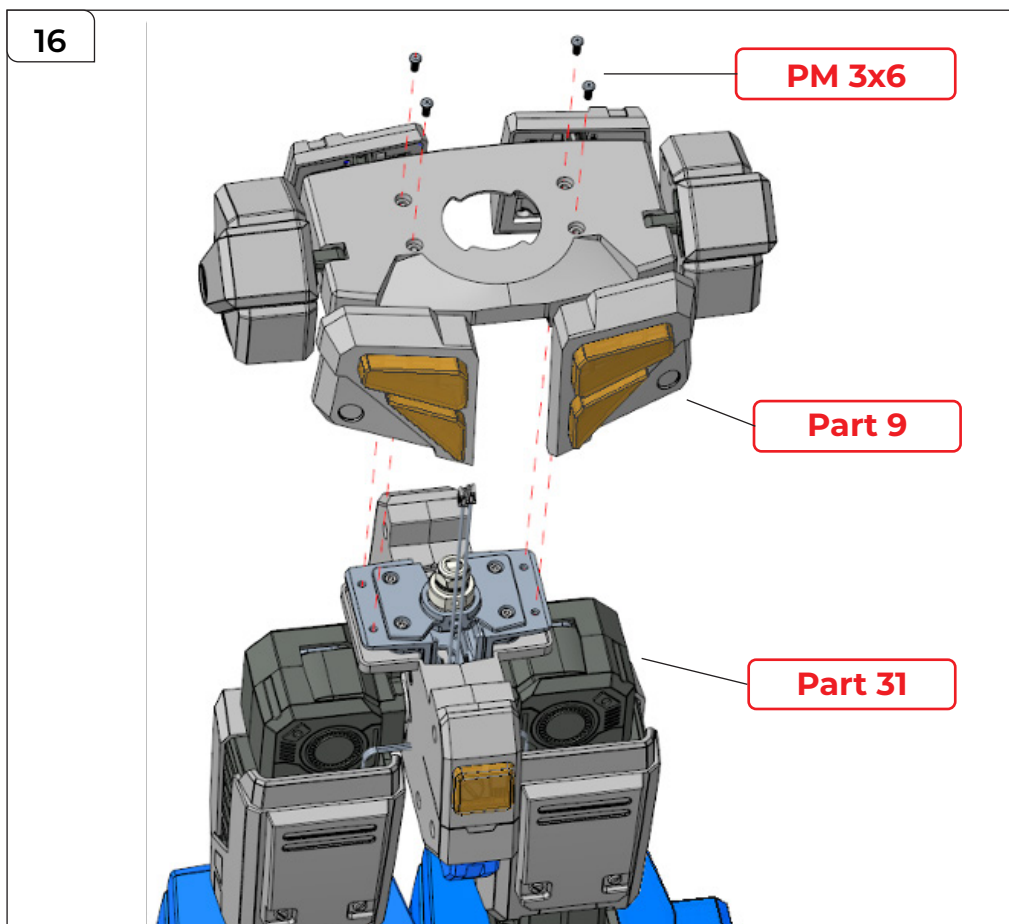

STEP 16

Attach part 9 to Part 31 and secure using 4x PM 3x6 mm screws.

Check that the wires continue to be routed through part 9.

Assembling the Hips and Attaching Them to the Legs

17

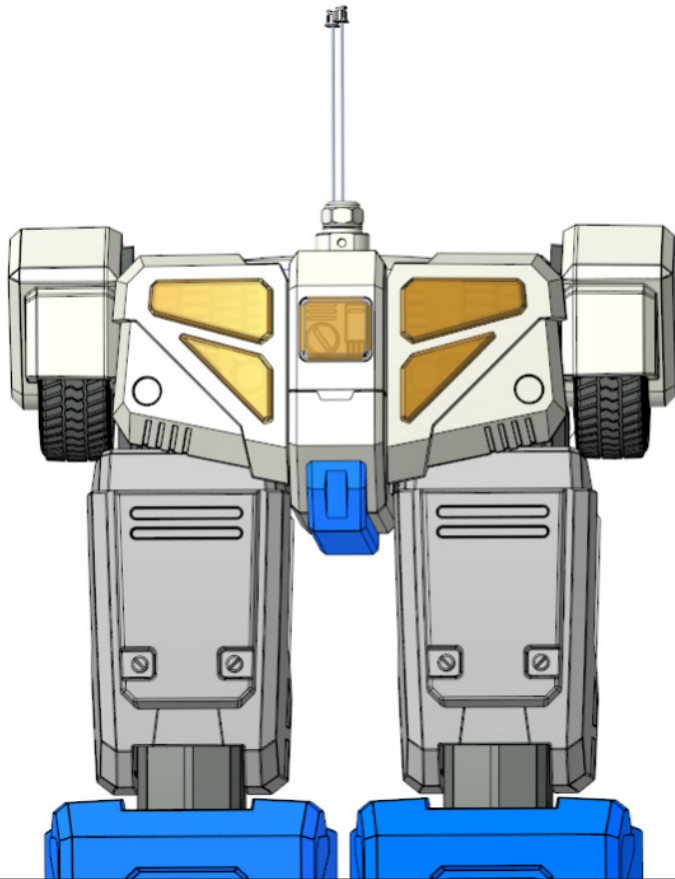

STEP 17

For the next stage of the build, the hip position must be rotated from the position shown in 17 to the position shown in 17a.

17a

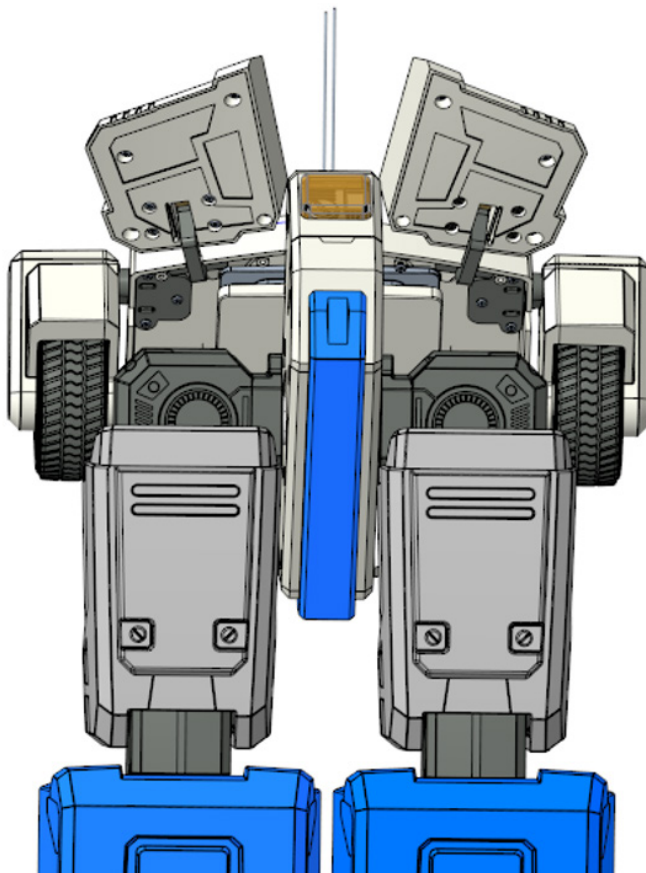

Assembling the Hips and Attaching Them to the Legs

18

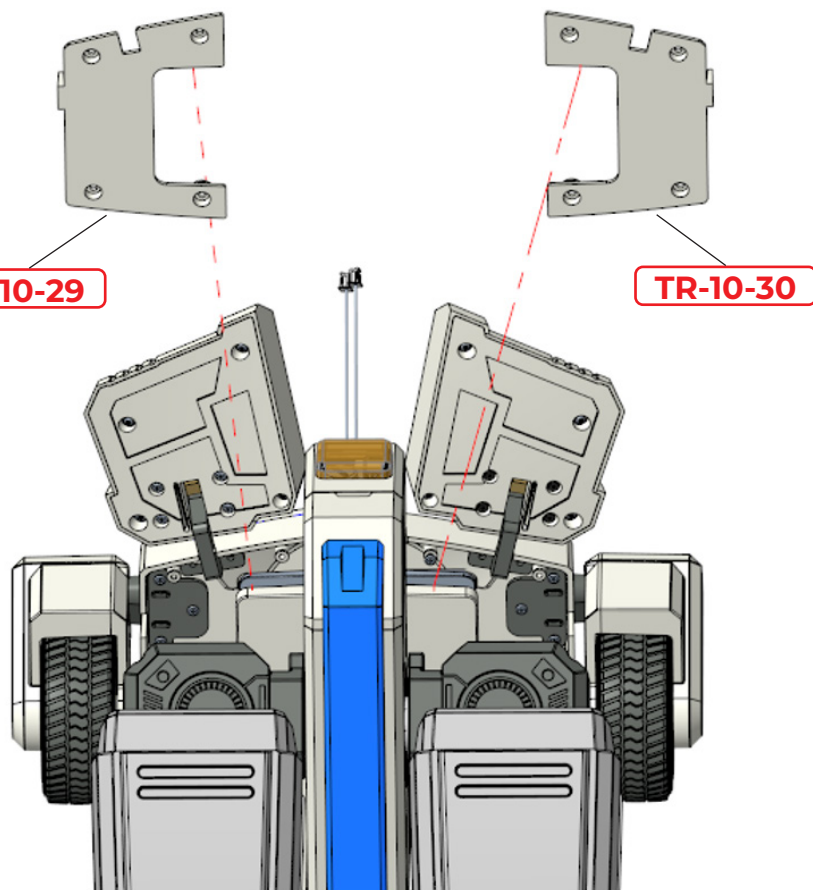

STEP 18

Attach TR-10-29 and TR-10-30 to the assembly as shown. These parts are attached at an angle, in the orientation shown

Secure them in place using 4x PB 2.3x6 mm screws.

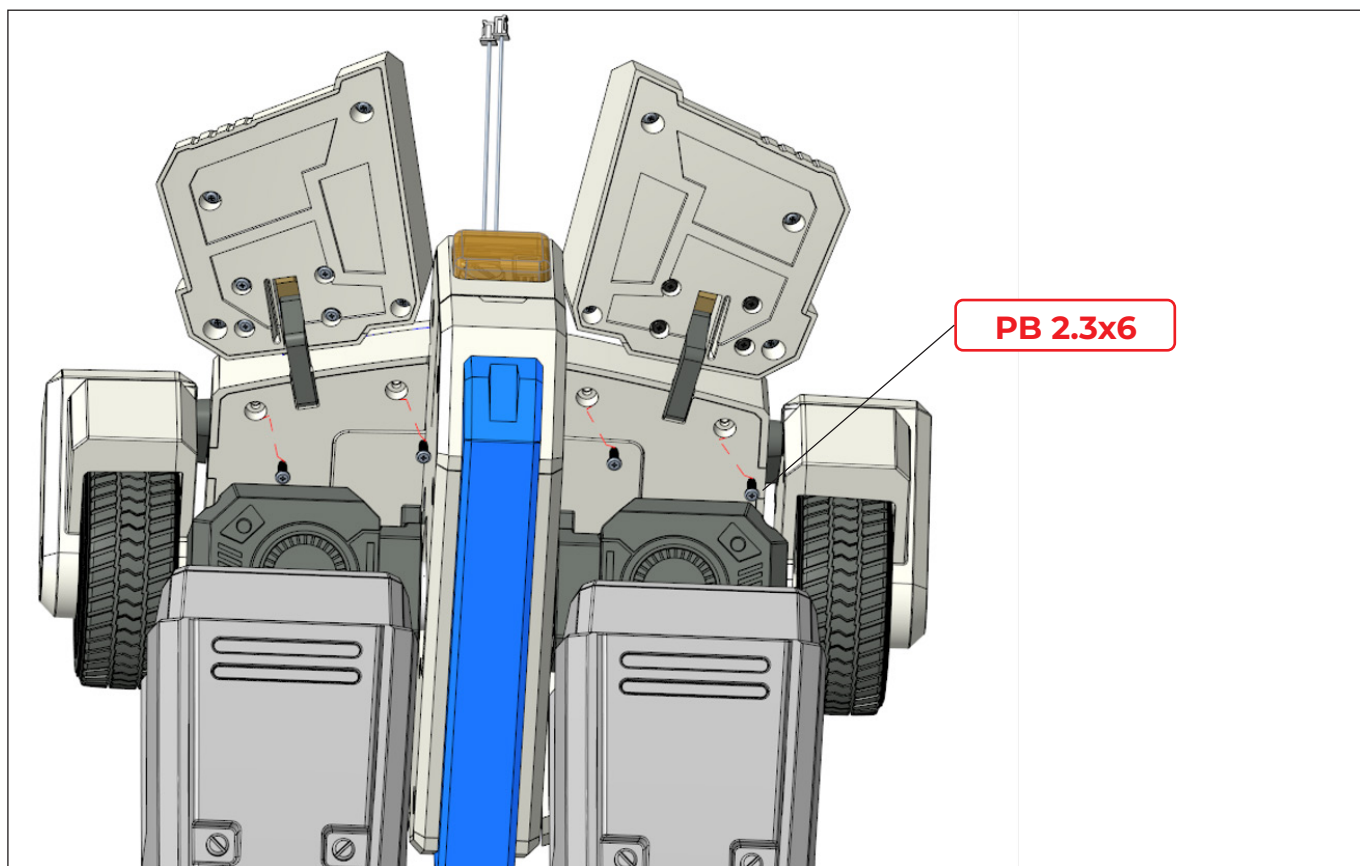

Assembling the Hips and Attaching Them to the Legs

19

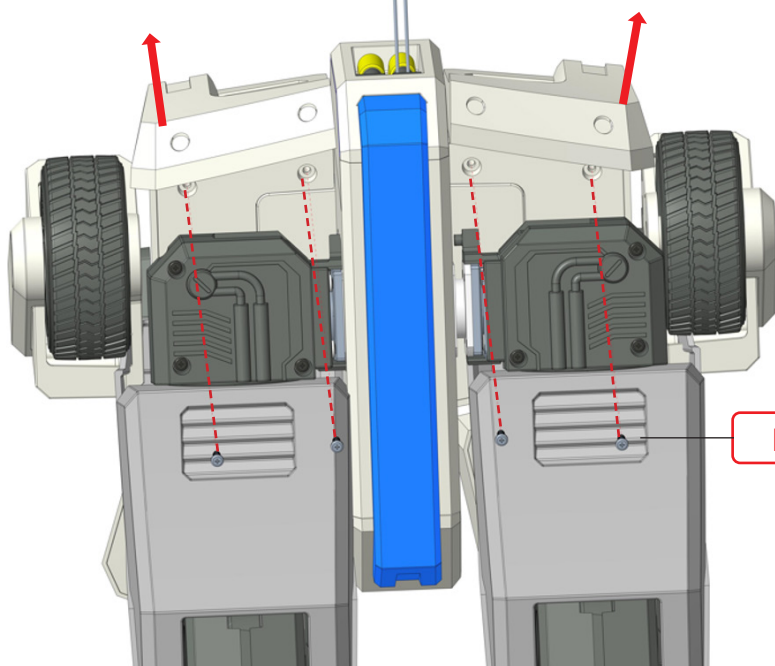

STEP 19

Turn the model assembly around so the opposite side is facing you. Bend the hips in the opposite direction to access the remaining screw holes in parts 29 & 30.

Drive 4x PB 2.3x6 mm screws into the holes, shown. You may need to lift the parts indicated by arrows to access the screw holes.

PB 2.3x6

PACK 10 COMPLETE

