

Ferrari

250 GTO



Pack 06

BUILD INSTRUCTIONS

STAGE 41: THE OIL FILTER
STAGE 42: THE STARTER MOTOR
STAGE 43: PIPES
STAGE 44: THE FUEL LINES

STAGE 45: THE FAN, FAN BELT AND FUEL HOSE
STAGE 46: MOUNTS AND BRACKETS
STAGE 47: THE LEFT HEADLIGHT
STAGE 48: THE RIGHT HEADLIGHT

Advice from the experts

To help you get the best out of building the Ferrari 250 GTO, we've prepared a modellers checklist with hints, tips and advice from our experts. The information below is aimed at making your build as enjoyable and professional as possible right from the start.

Have a soft cloth ready to place on your work surface to prevent scratching the paintwork.

Spare screws are included with each part. Occasionally, you may be instructed to keep spare or unused screws for a later stage. Keep these spares in a safe place and label them correctly.

Please make sure you don't mix up the screws. They look quite similar, but the threads do vary slightly. Using the wrong screws may damage the parts.

When securing parts together using multiple screws, fit each screw loosely to ensure all the parts are correctly aligned before gently tightening them firmly, but not overtight, in the order in which you placed them.

The screwdriver can be magnetized by stroking it with a magnet (fridge magnet, etc.) enabling it to hold the screws and make assembly easier.

If a screw is tight going into a metal part, do not force it as you may shear the head off. Remove it and put a tiny smear of Vaseline, soap or light oil on the thread. That will lubricate it and make it easier to drive home.

Only use the correct size screwdriver that fits the screw head firmly.

Use a magnet to help find screws that have fallen on the floor.

Use masking tape to hold parts temporarily in place.

Cut parts from a sprue (framework) with side cutters or a craft knife. Side cutters tend to be easiest.

During the course of this build, you will receive many pieces that you will assemble immediately – following the instructions in the corresponding stage – and other pieces that you should store safely to one side, for use in future assembly stages.

Left and Right! When building your *Ferrari 250 GTO*, the left- or right-hand side refers to that side as if you are sitting in the car.



WARNING: Some parts are assembled using magnets. These magnets can cause serious injury if they are swallowed. Keep away from children. If you suspect a magnet has been swallowed, seek medical help straight away.

All parts belong to a kit. Collectors item for adults.

Not suitable for children under 14.

Produced under license of Ferrari S.p.A. The name FERRARI, the PRANCING HORSE device, all associated logos and distinctive designs are property of FERRARI S.p.A. The body designs of the Ferrari cars are protected as Ferrari S.p.A. property under design, trademark and trade dress regulations.

Stage 41: The Oil Filter

In this stage you'll assemble the oil filter and fit the timing chest to the engine block.



STAGE 41 PARTS LIST

Name	Name
1 Oil filter body	2 type B screws
2 Oil filter base	2 type C screws
3 Detail A	
4 Detail B	
5 Front cover of the timing chest	



Stage 41: The Oil Filter

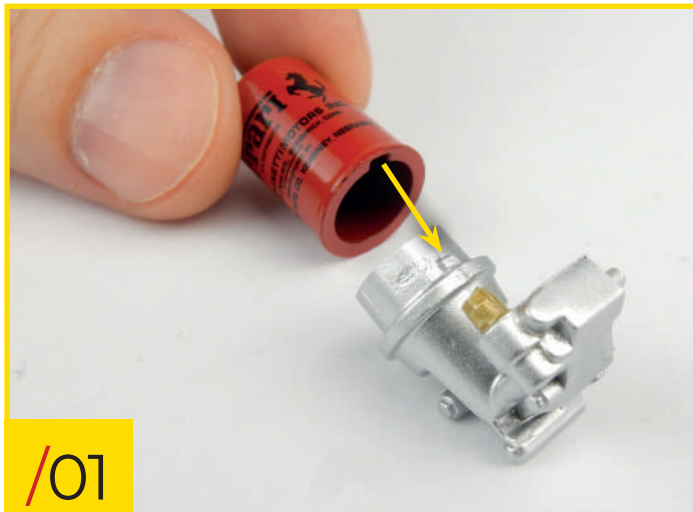

41/01 Fit the two parts of the oil filter together as shown in the photo. There's only one way that the components will fit together.

41/02 Take the dynamo and the timing chest. Push the dynamo onto the dynamo bracket, then clip the arm over the two pins on the timing chest.

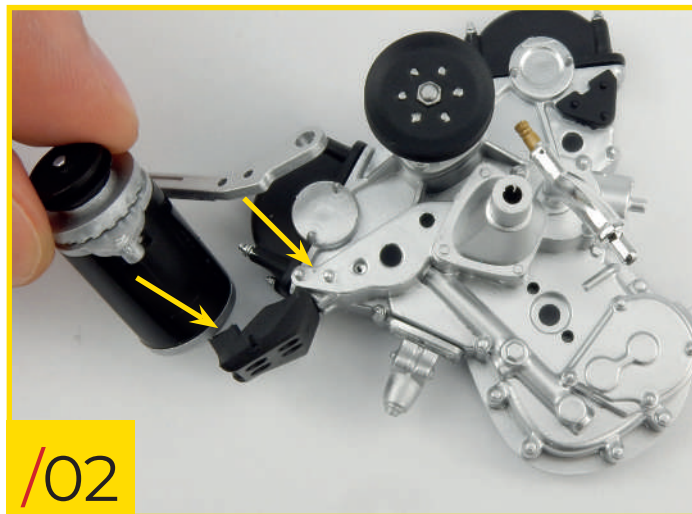

41/03 Now add the oil filter by inserting the stud on its base into the hole indicated in the photo.

41/04 Turn the timing chest over and secure the pieces together using a type B screw.

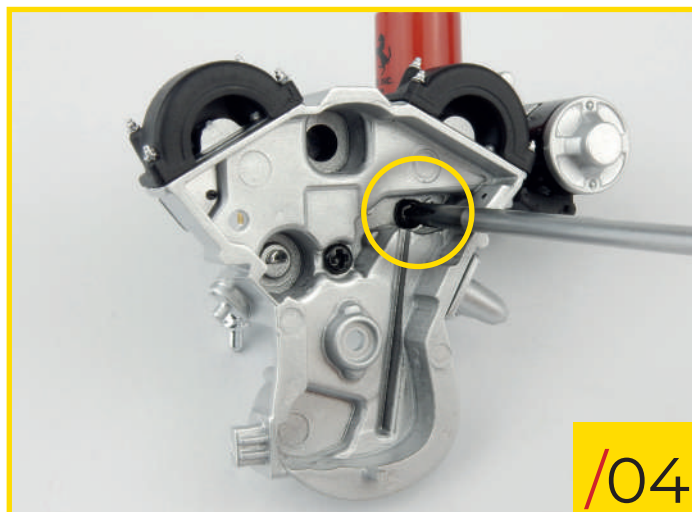

Stage 41: The Oil Filter

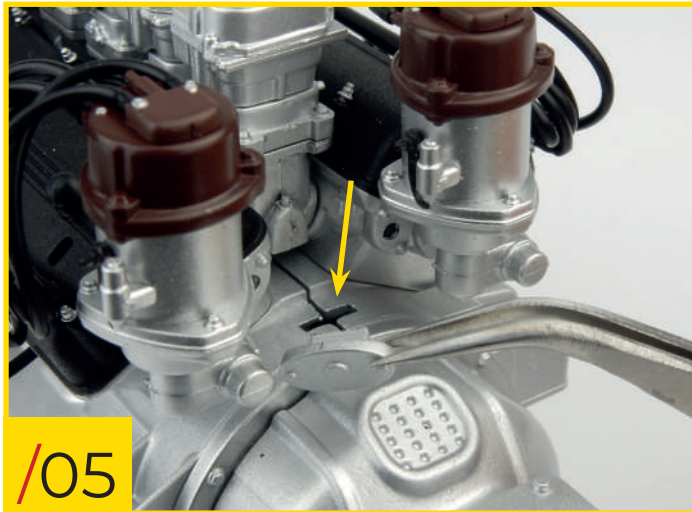

41/05 Retrieve the engine block and insert detail A into the slot indicated in the photo.

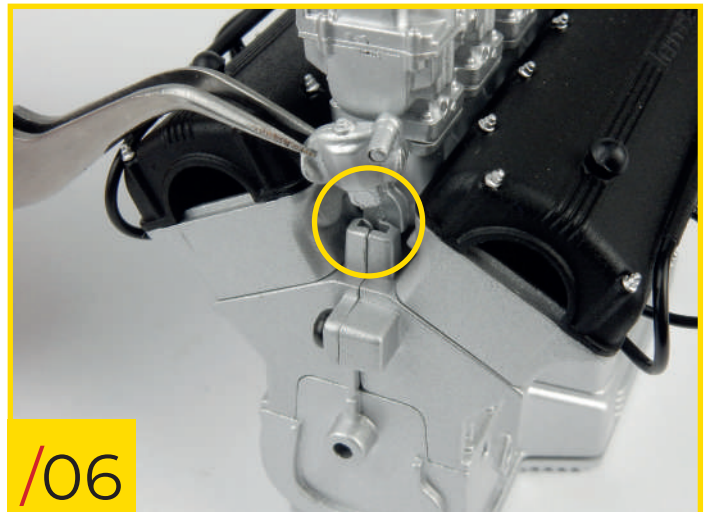

41/06 Insert detail B into the slot on the other end of the engine block, as indicated in the photo.

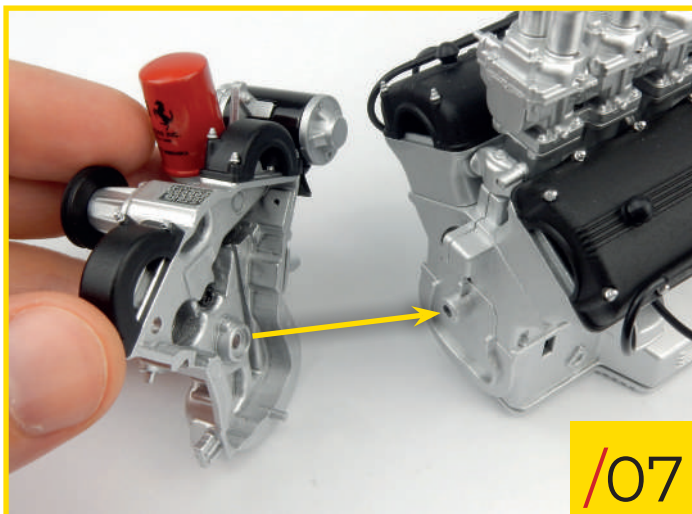

41/07 Fit the timing chest to the engine block.

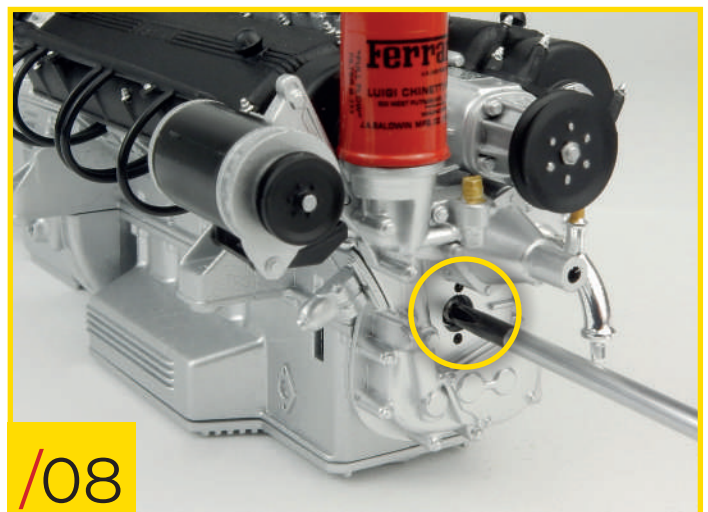

41/08 Secure the timing chest to the engine block using a type C screw.

Stage 41: The Oil Filter

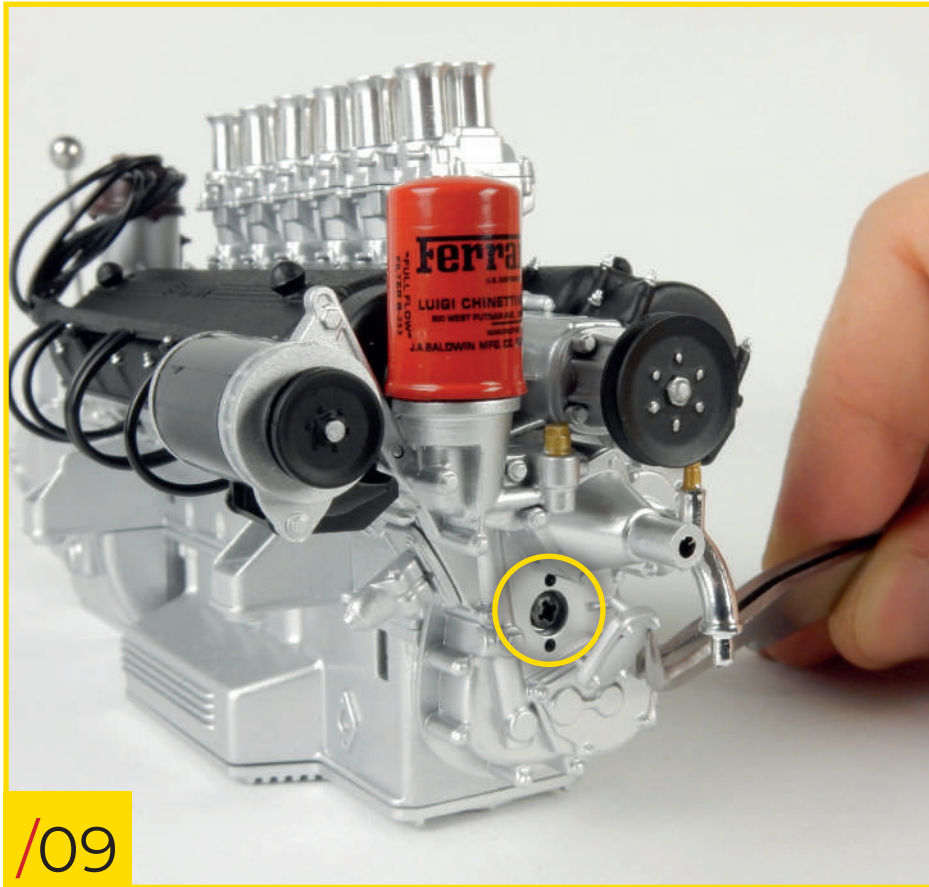

41/09 Finally, add the front cover by pressing the two studs into the holes in the timing chest.



STAGE 41 IS COMPLETE
Here's how your model's engine block looks at the end of this assembly stage.

Stage 42: The Starter Motor

In this stage you'll assemble the starter motor and fit it to the engine block.



STAGE 42 PARTS LIST

Name	Name
1 Starter motor body	2 type D screws
2 Starter motor end cover	
3 Bracket	
4 Starter motor base	
5 Solenoid	



Stage 42: The Starter Motor

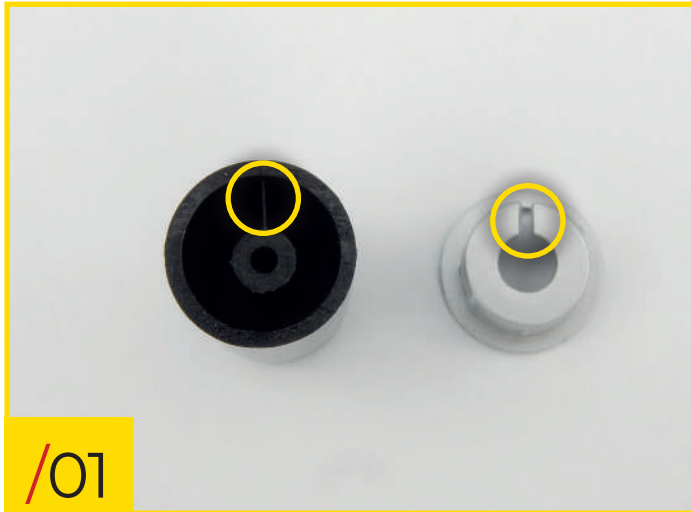

42/01 Fit the starter motor end cover to the starter motor body; there's only one way that the pieces will fit together.

42/02 Look at the photo to check that you've fitted the pieces together correctly.



42/03 Now add the bracket to the assembly.

42/04 Fit the starter motor base to the rest of the assembly, using the photo and the shape of the pieces as a guide.



Stage 42: The Starter Motor



42/05 Secure all the pieces together using a type D screw.

42/06 Now fit the solenoid to the assembly, by lining up the raised detail on the bracket with the corresponding notch on the outer edge of the solenoid.

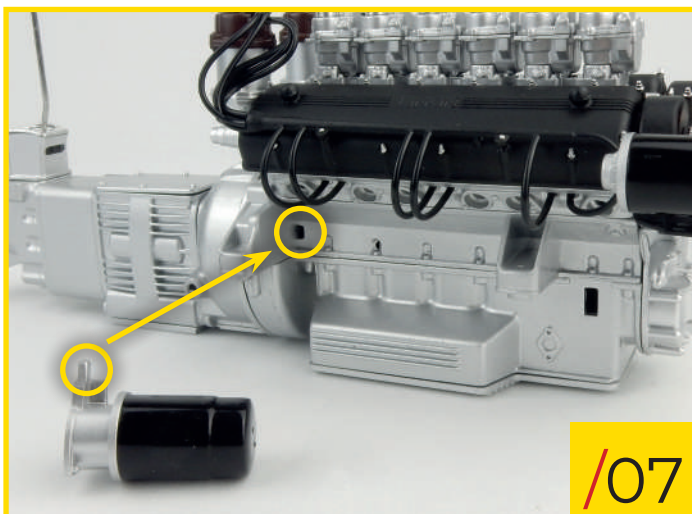

42/07 Retrieve the engine block you assembled in the previous stages. Add the starter motor to the engine block by inserting the stud on its base into the hole shown in the photo.

Stage 42: The Starter Motor

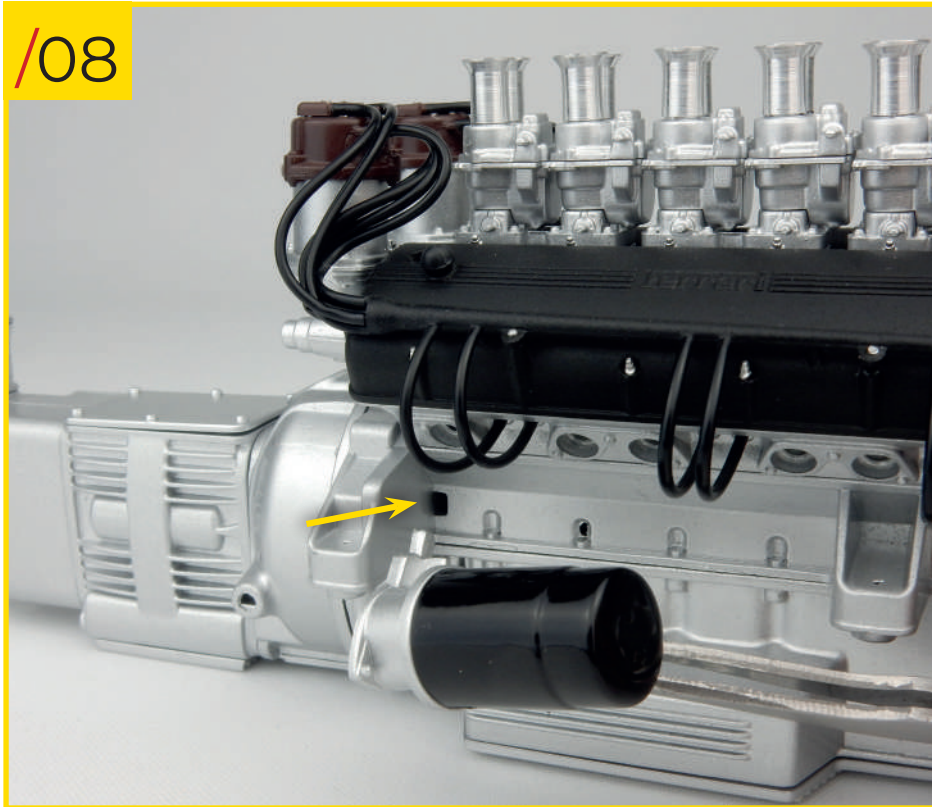

42/08 Carefully push the starter motor in place.



STAGE 42 IS COMPLETE
Here's how your model's
engine block looks at the
end of this session.

Stage 43: Pipes

In this stage you'll add some pipes and other components to your model's engine block.



STAGE 43 PARTS LIST

Name
1 Oil filler pipes
2 Oil filler caps
3 Water pipe
4 Oil sump cap
5 Coolant pipe



Stage 43: Pipes

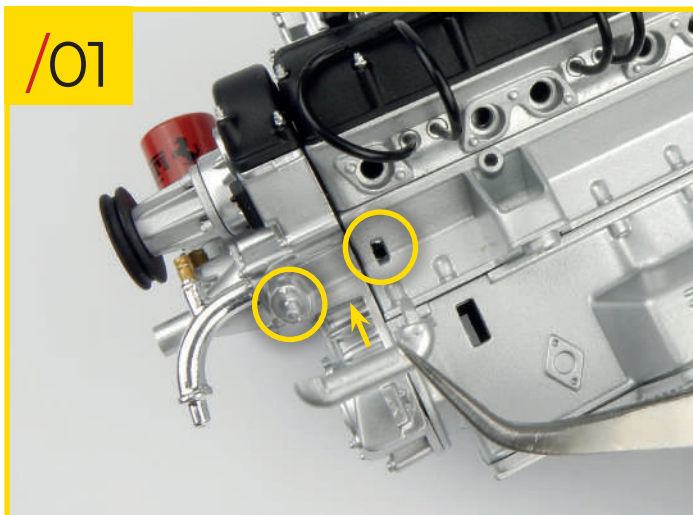

/01

43/01 Retrieve the engine block and fit the water pipe into the position indicated in the photo.

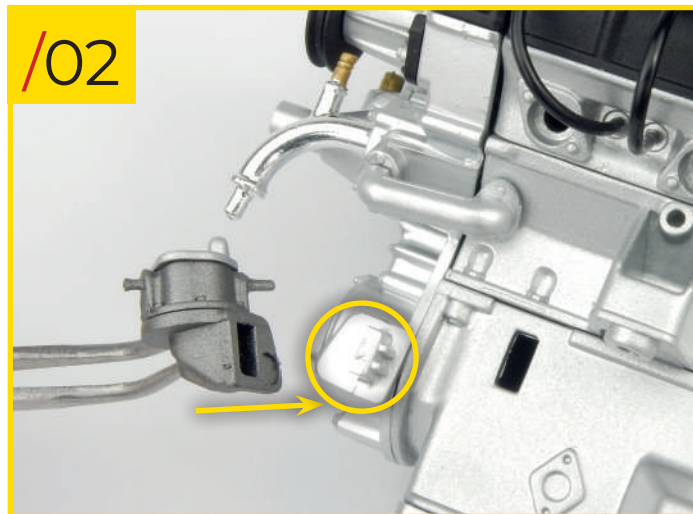

/02

43/02 Retrieve the fuel pump you assembled in stage 39 and fit it to the engine block over the circled detail in the photo.

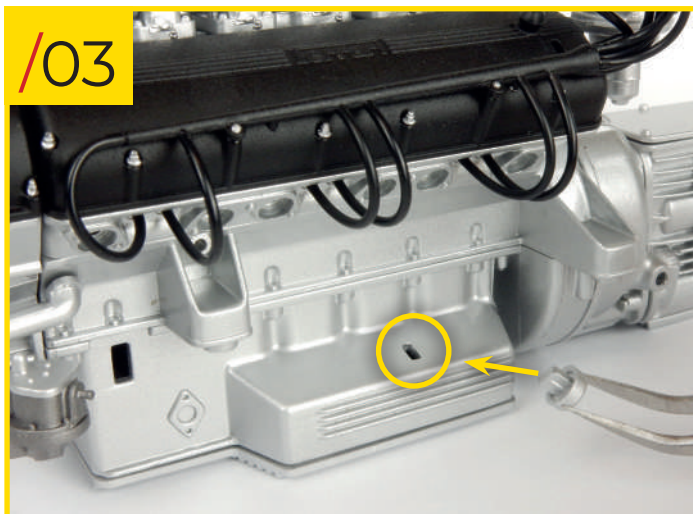

/03

43/03 Fit the oil sump cap in into the opening indicated in the photo.

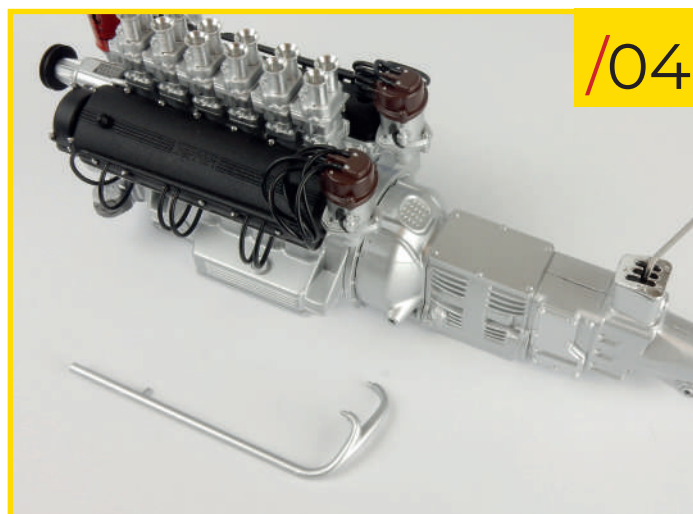

/04

43/04 Place the coolant pipe and engine block on your work surface as shown in the photo.

Stage 43: Pipes

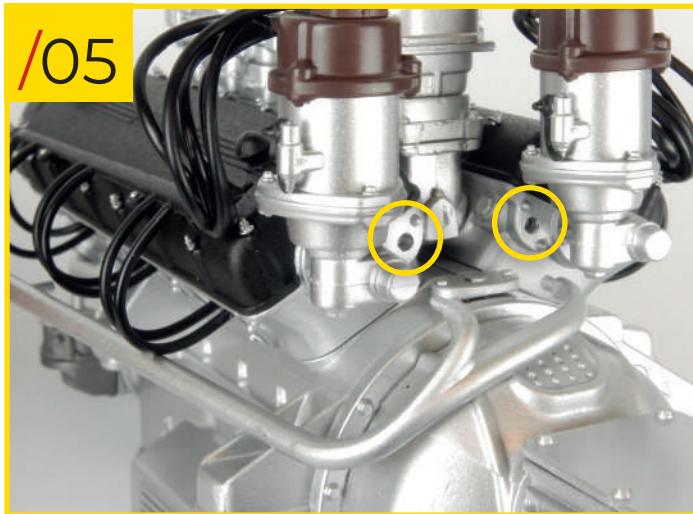

43/05 Insert the two small studs on the forked end of the pipe into the holes in the cylinder heads.

43/06 Now insert the remaining stud on the coolant pipe into the hole indicated in the photo.

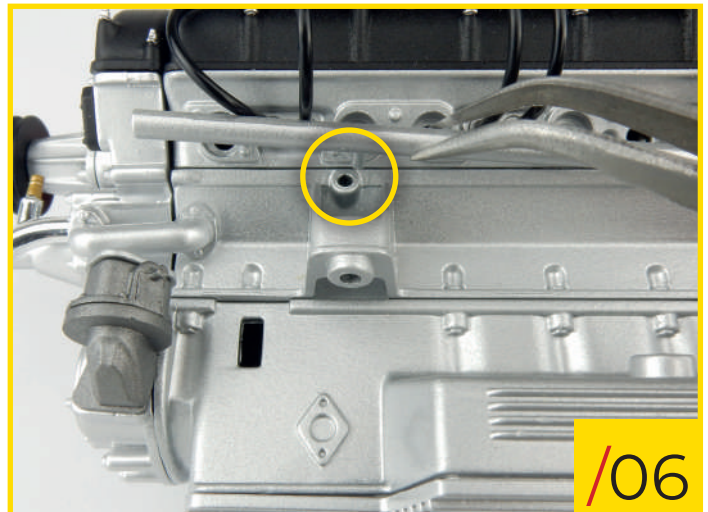

43/07 Insert the oil filler caps into the open end of the oil filler pipes.

43/08 Push the first oil filler pipe into the hole on the left side of the engine block.



Stage 43: Pipes

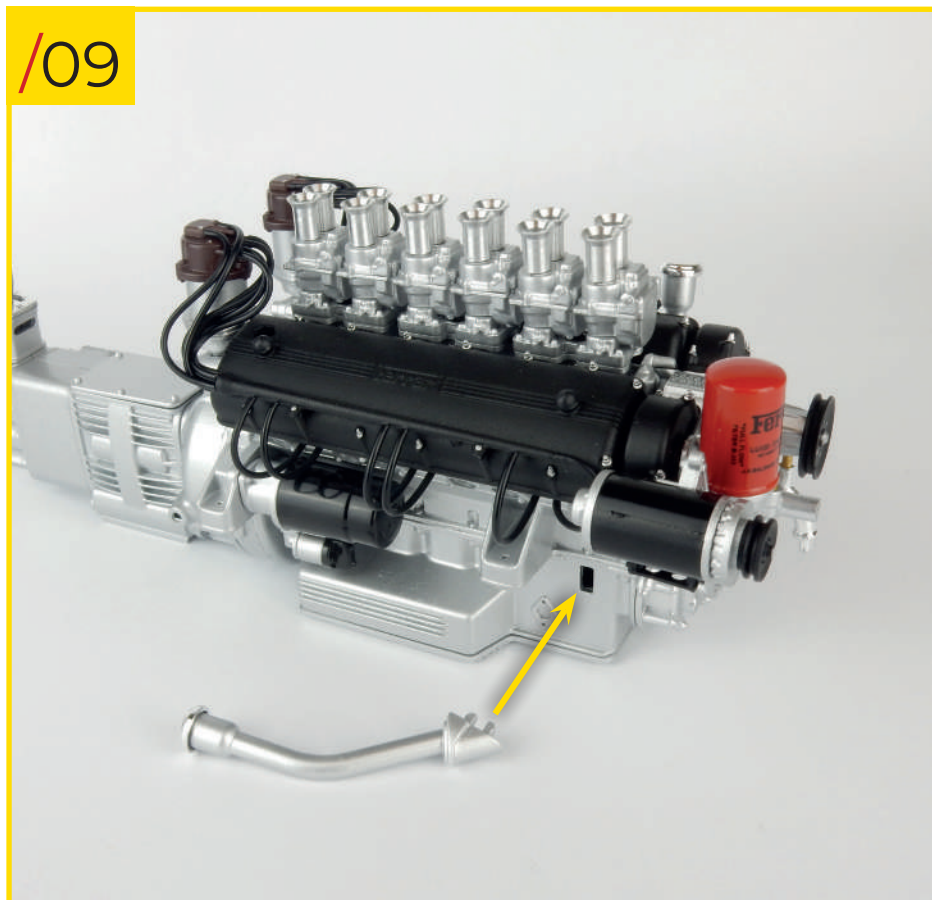

43/09 Fit the second oil filler pipe into the hole on the right side of the engine block.

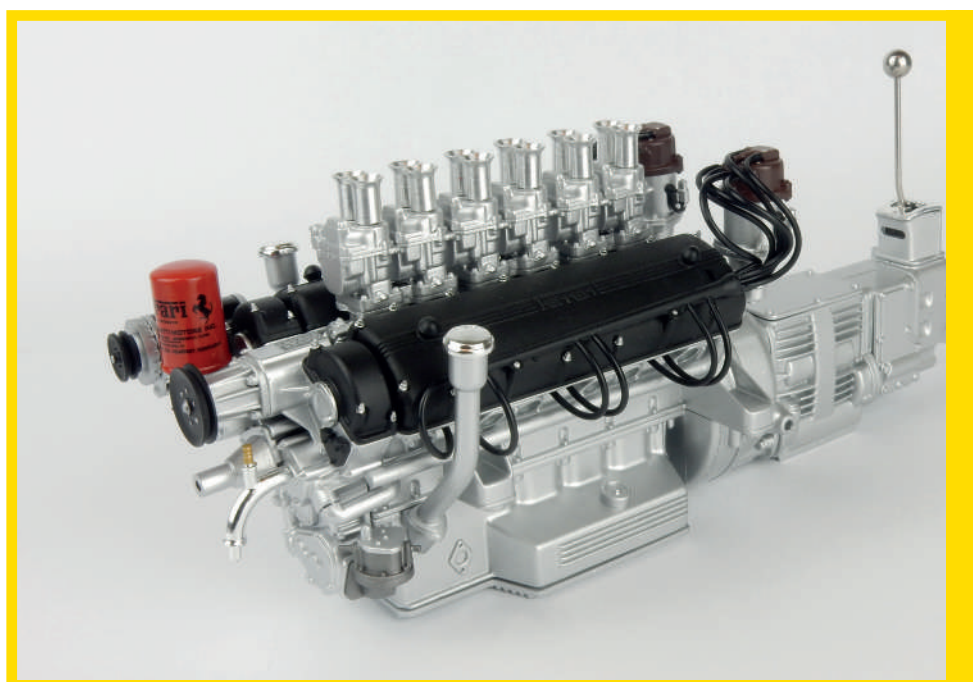

STAGE 43 IS COMPLETE
Here's how your model's engine block looks at the end of this stage.

Stage 44: The Fuel Lines

In this stage you'll fit the fuel lines and some other components to the engine block.



STAGE 44 PARTS LIST

Name
1 Fixing - right cylinder head
2 Base for the right cylinder head fixing
3 Fixing - left cylinder head
4 Fuel line A
5 Connector pipe
6 Fuel line B

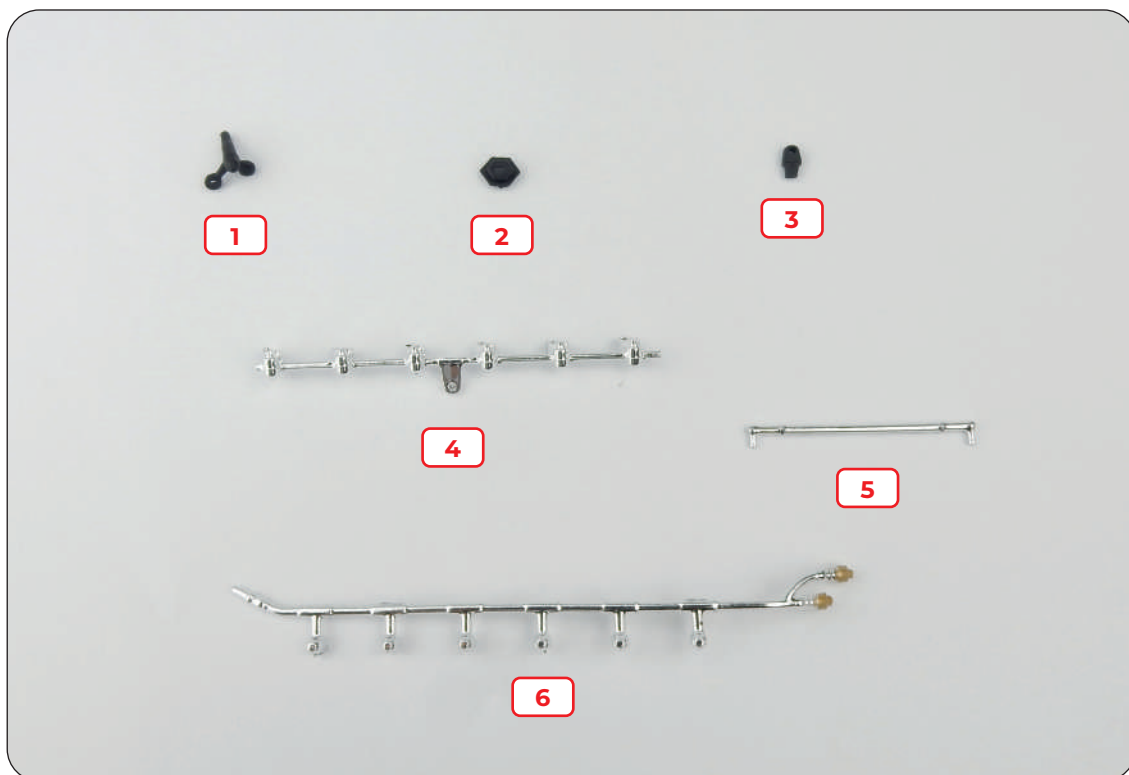

Stage 44: The Fuel Lines



44/01 Fit the right cylinder head fixing into its base. There's only one way that the pieces will fit together.

44/02 Look carefully at the shape of the base, highlighted in the photo. This will help you in the following step.

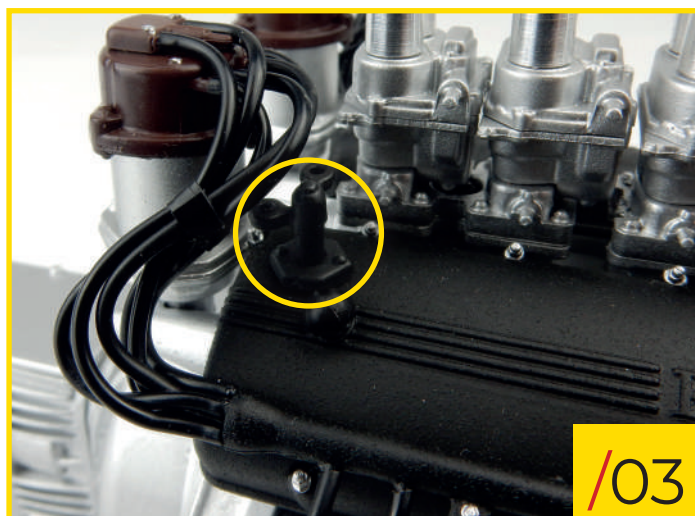

44/03 Retrieve the engine block. Insert the base into the hexagonal hole on the right cylinder head. The arms should point towards the rear and the centre of the engine.

44/04 Insert the left cylinder head fixing into the rectangular hole in the left cylinder head.

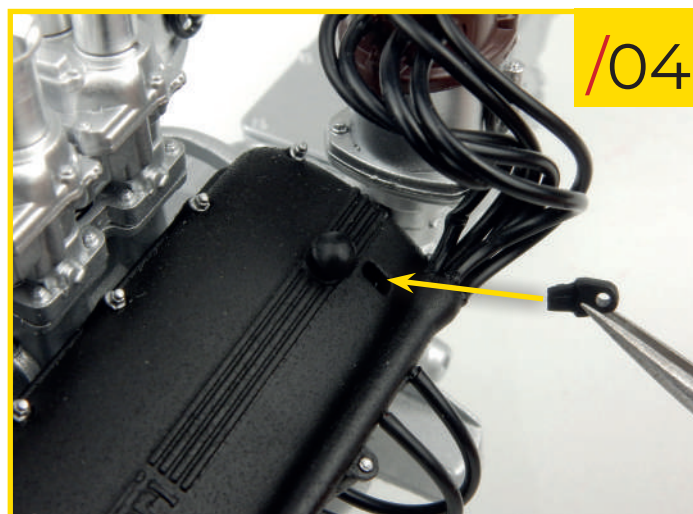

Stage 44: The Fuel Lines

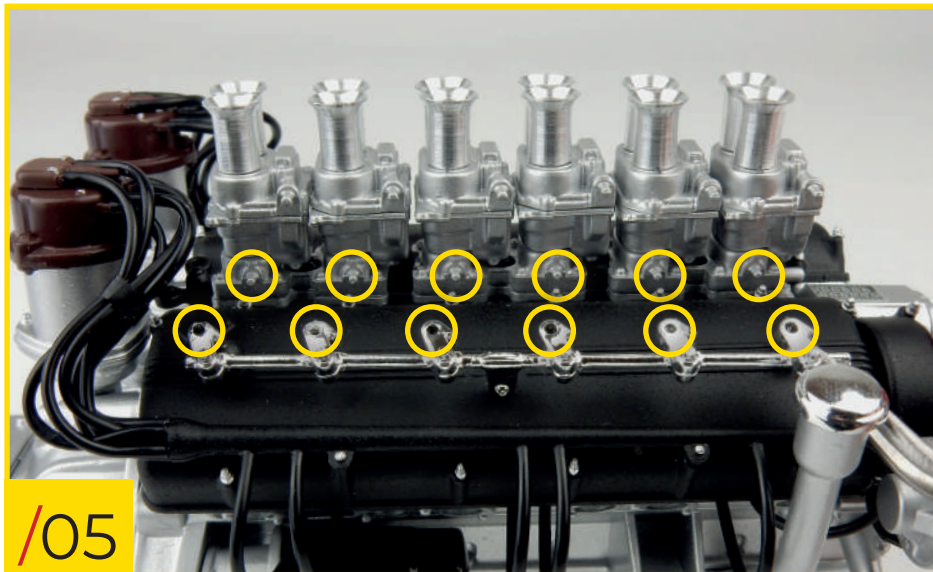

44/05 Fit the fuel line A to the carburetors on the right cylinder head by lining up the interlocking details highlighted in the photo.

44/06 Look at the photo to check that you've correctly installed the fuel line A.

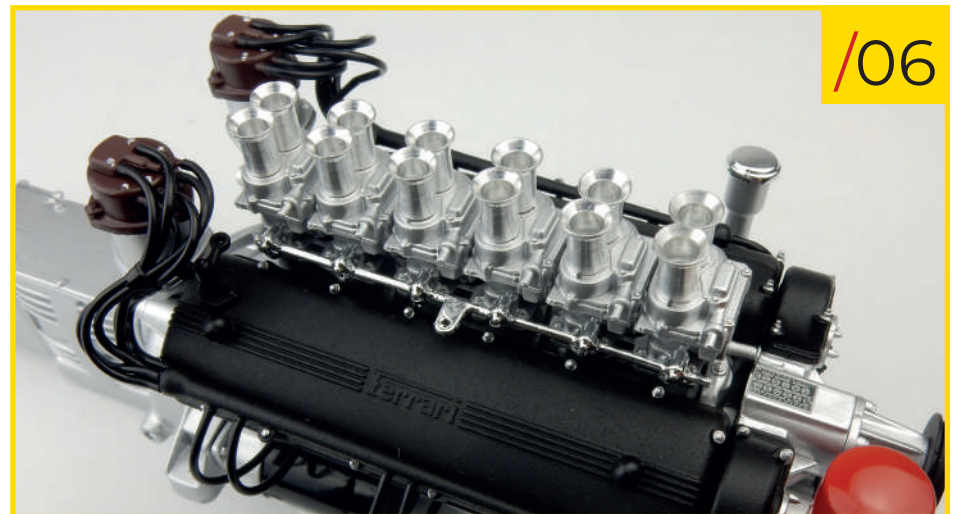

44/07 Fit the connector pipe as shown, inserting its studs into the holes in the fuel line A and in the right cylinder head fixing, highlighted in the photo.

Stage 44: The Fuel Lines

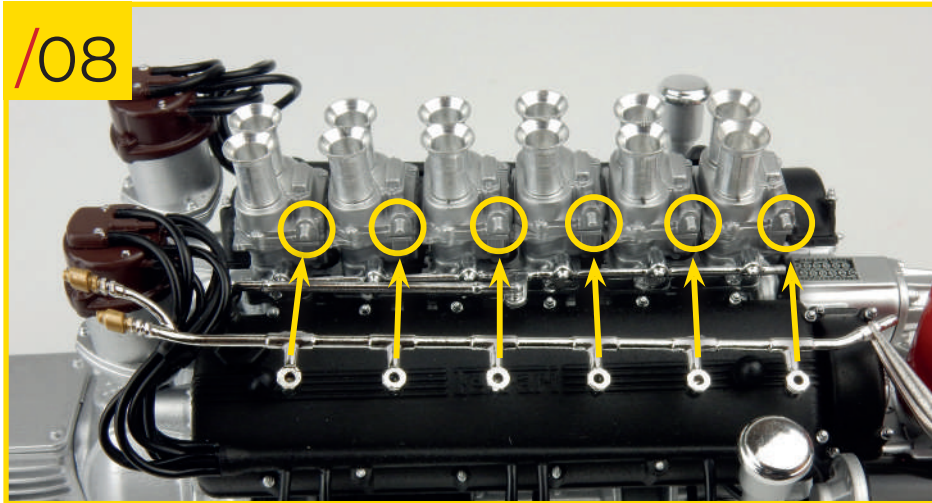

44/08 Fit the fuel line B to the carburettor assembly, using the photo to fit the pieces together correctly.

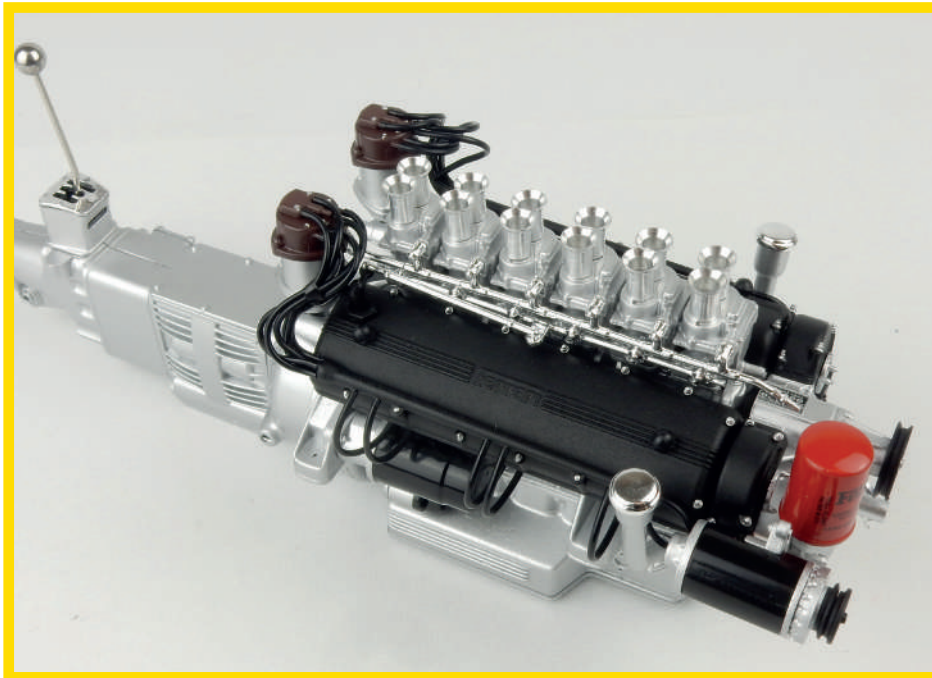

STAGE 44 IS COMPLETE
Here's how the engine block looks after the fuel lines have been fitted.

Stage 45: The Fan, Fan Belt and Fuel Hose

In this stage you'll add important components to your model's engine block assembly: the fan, fan belt and fuel hose.



STAGE 45 PARTS LIST

Name	Name
1 Pulley - part A	5 Clutch lever
2 Pulley - part B	6 Fuel hose
3 Fan belt	
4 Fan	2 type D screws

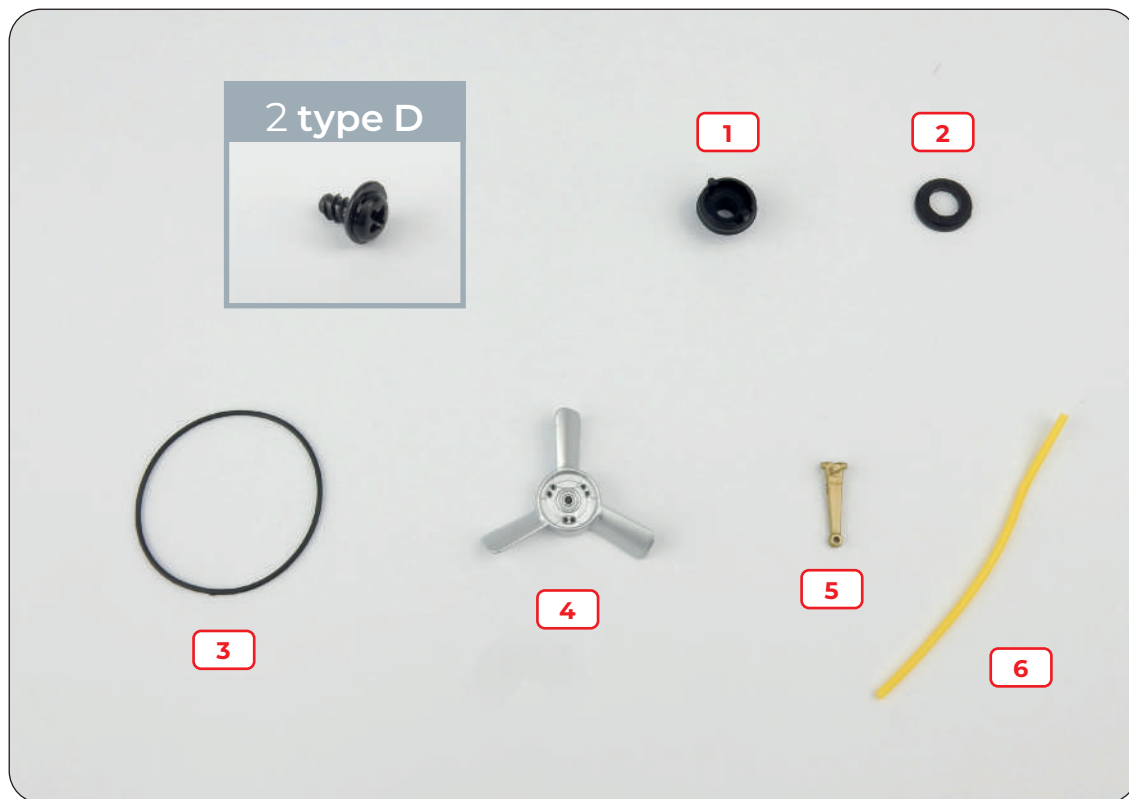

Stage 45: The Fan, Fan Belt and Fuel Hose

/01



45/01 Fit the two parts of the pulley together, orientating them as shown in the photo.

/02

45/02 Fit the pulley to the fan mount; the side of the pulley with two studs should be facing outwards.

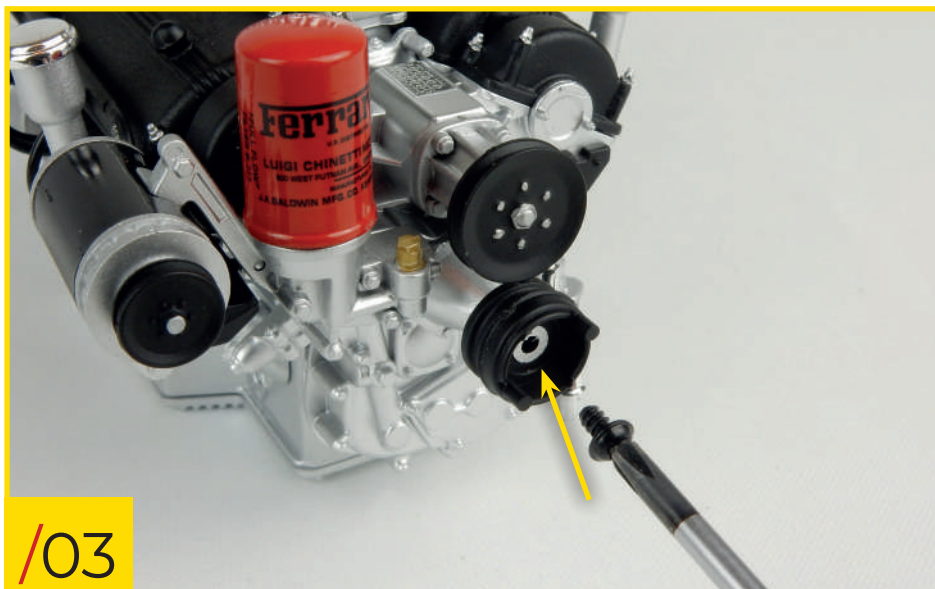
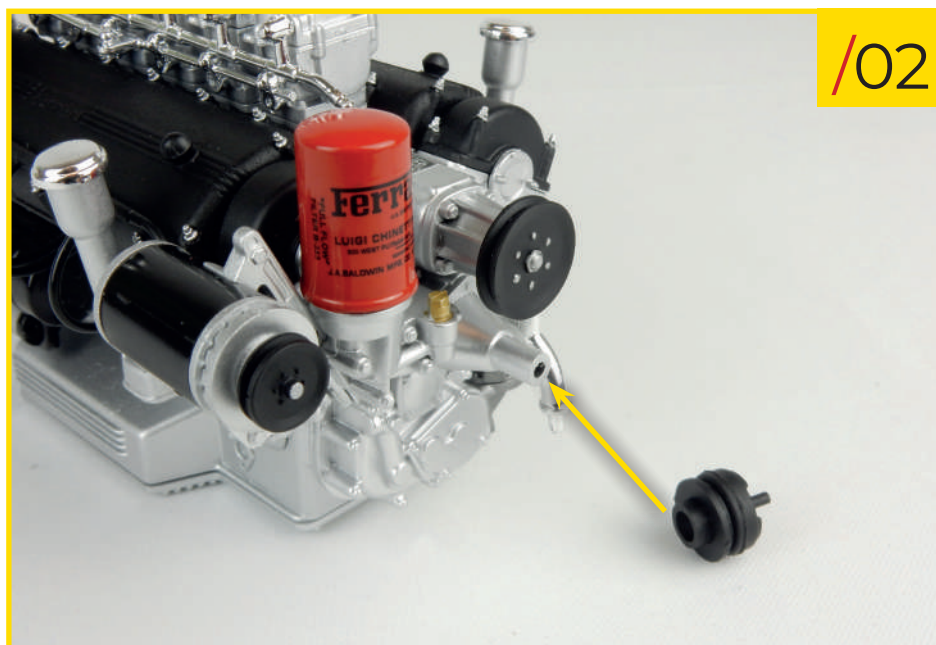

/03

45/03 Use a type D screw to secure the pieces together.

Stage 45: The Fan, Fan Belt and Fuel Hose

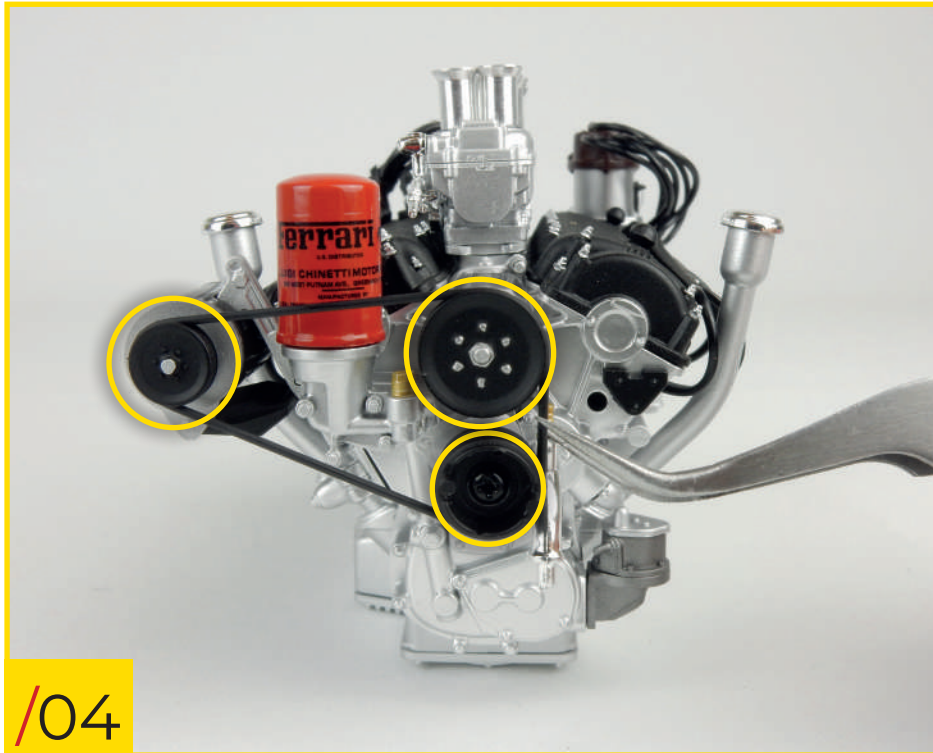

45/04 Using a pair of tweezers and being careful not to twist it, place the belt onto the pulleys as shown. Make sure all three pulleys on the front of the engine block are linked together.

45/05 Fit the fan to the pulley with two studs on it.

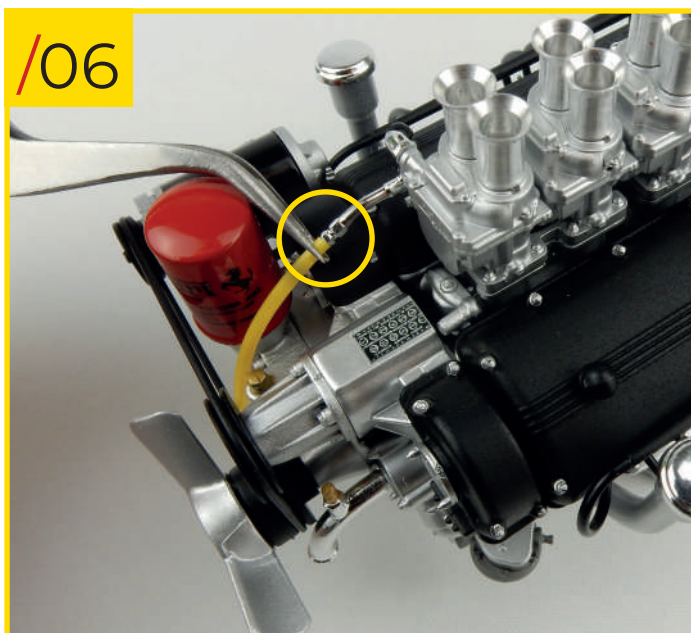
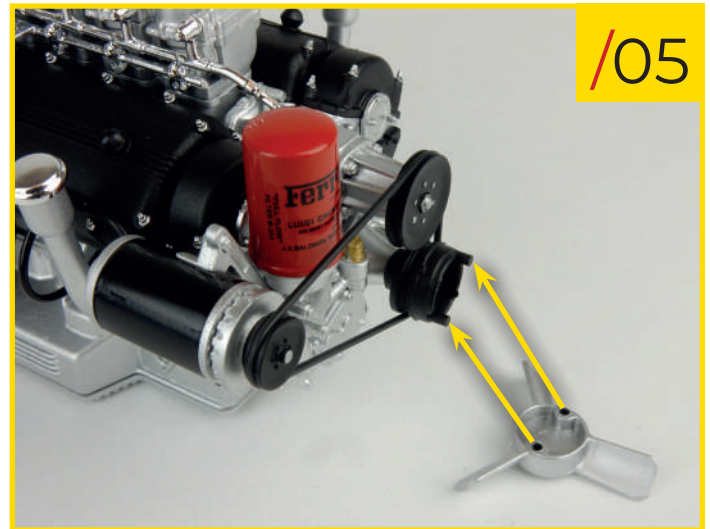

45/06 Slide one end of the fuel hose onto the nozzle on the fuel line, as indicated in the photo.

Stage 45: The Fan, Fan Belt and Fuel Hose

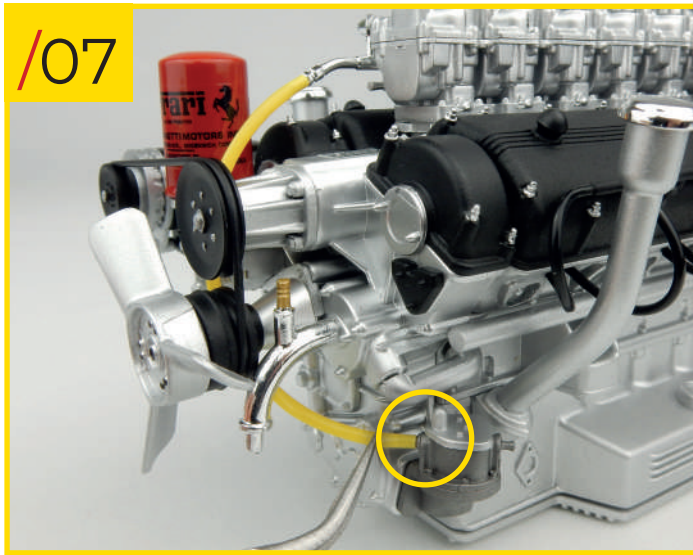

45/07 Make sure the fuel hose passes behind the fan belt and then push the other end of the fuel hose onto the stud on the fuel pump, as shown in the photo.

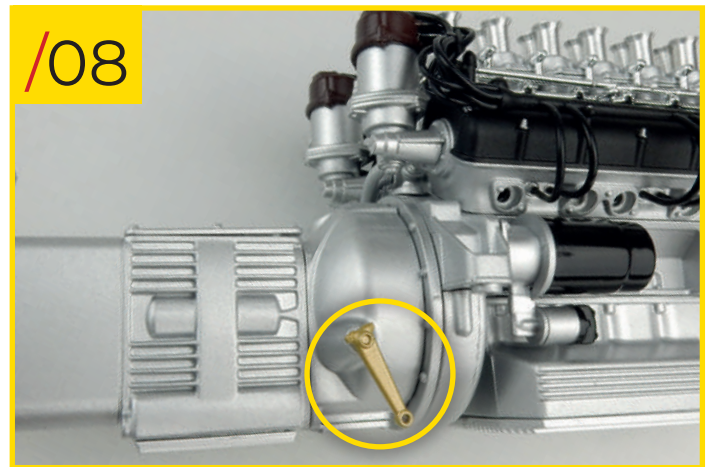

45/08 Using the hole that's available on the right side of the clutch bell, fit the clutch lever to the clutch bell.

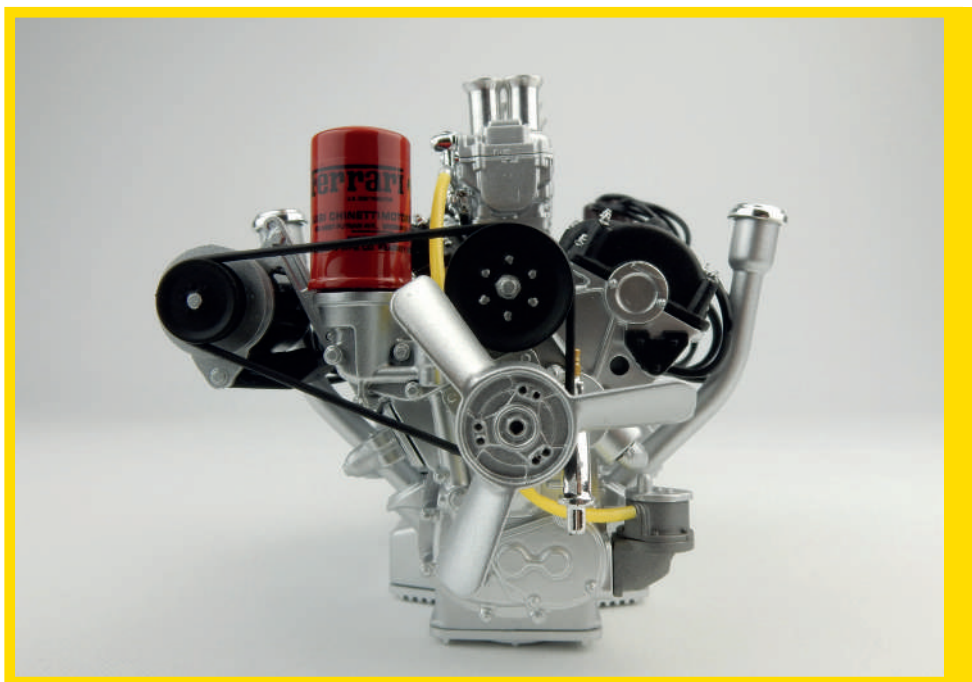

STAGE 45 IS COMPLETE
Here's how your model's engine looks at the end of this assembly stage.

Stage 46: Mounts and Brackets

In this stage you'll fit mounts and brackets for the shock absorbers, chassis, and exhaust.



STAGE 46 PARTS LIST

Name	Name
1 Shock absorber bracket "L"	9 type B screws
2 Shock absorber bracket "R"	3 type G screws
3 Chassis mount	
4 Exhaust clamps	



Stage 46: Mounts and Brackets

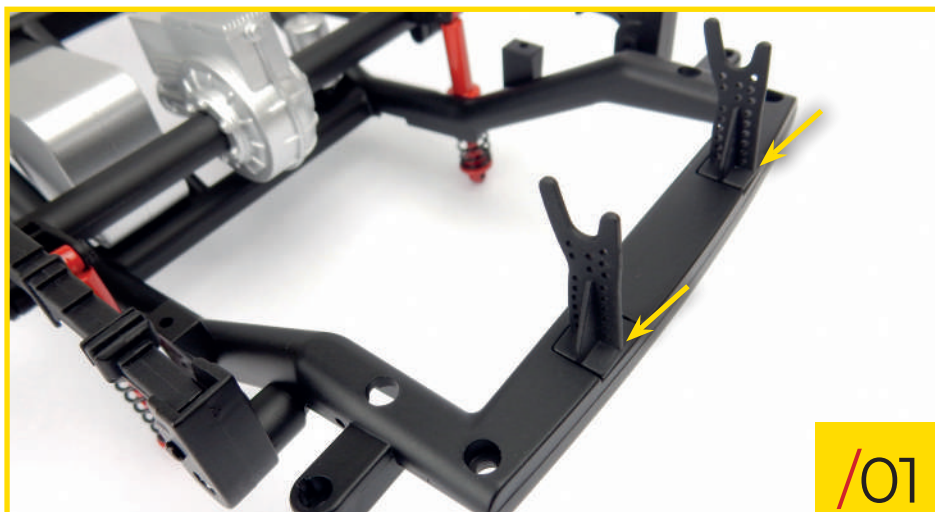

46/01 Retrieve your model's chassis and fit the two chassis mounts into the positions indicated in the photo.

46/02 Secure the mounts to the chassis using two type B screws.

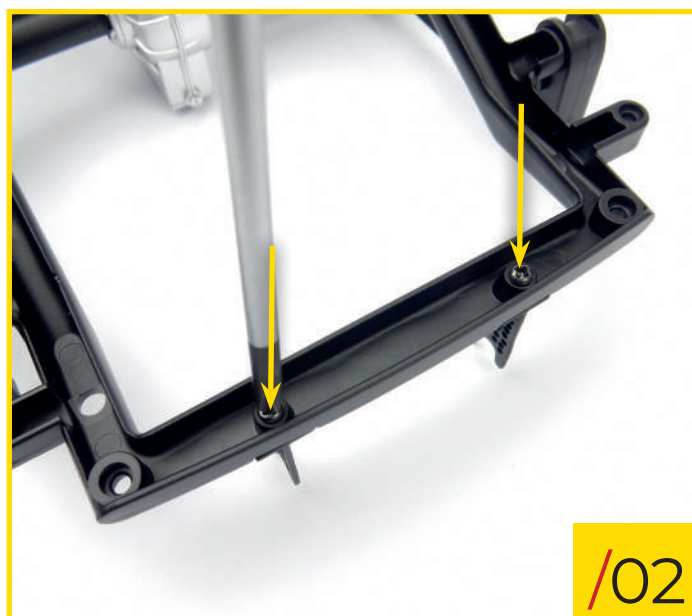

46/03 Fit the two exhaust clamps into their positions, as shown.

46/04 Secure the exhaust clamps using another two type B screws.

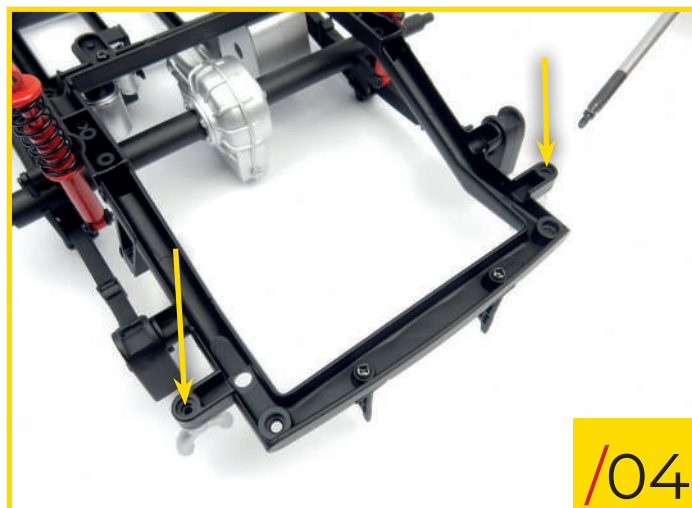

Stage 46: Mounts and Brackets

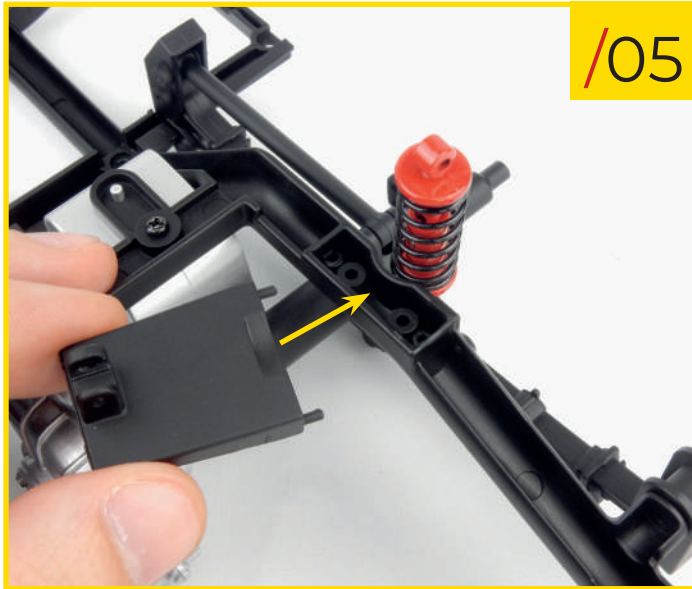

46/05 Fit the right shock absorber bracket (with the letter "R" marked on it) into its position on the chassis.



46/06 Secure the bracket to the chassis by screwing two type B screws into the holes indicated.

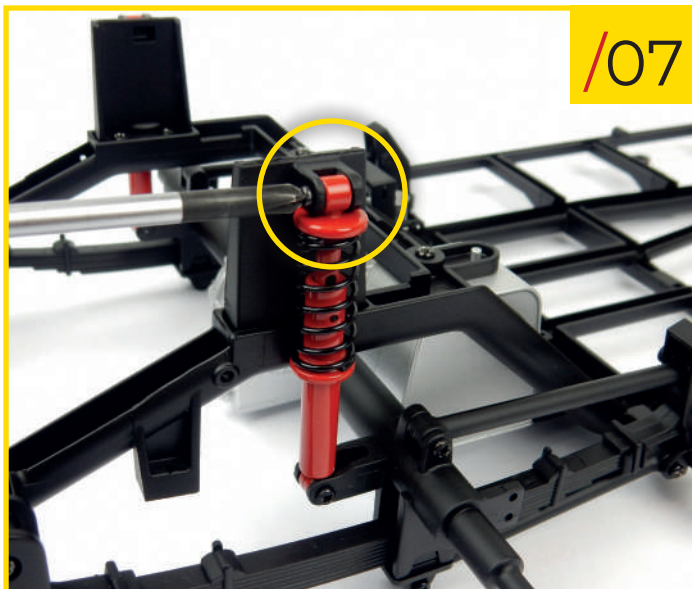

46/07 Using a type G screw, secure the right shock absorber to the bracket. You may need to remove excess red paint.

Stage 46: Mounts and Brackets

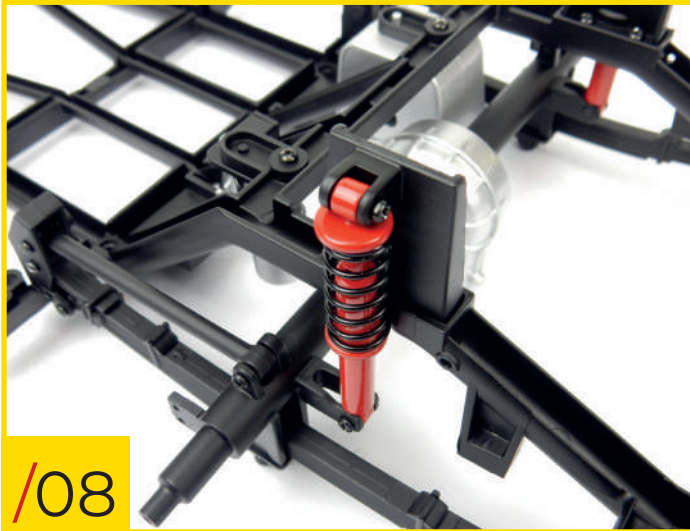

46/08 Repeat steps 06 and 07 to fit the left shock absorber bracket (marked with the letter "L") to the left side of the chassis and then secure the left shock absorber to it.

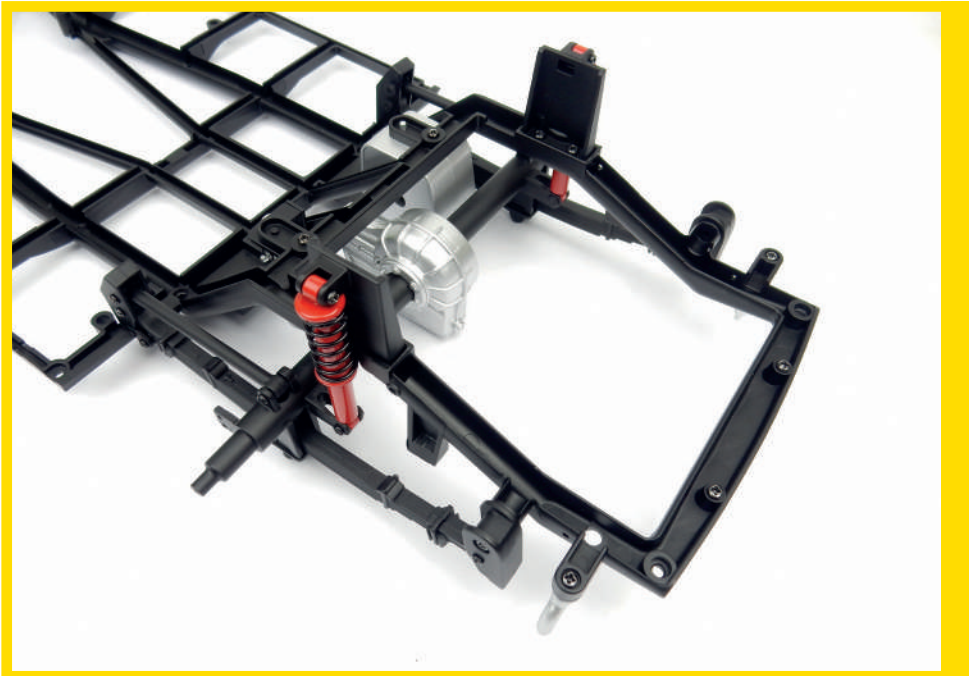

STAGE 46 IS COMPLETE
Here's how the rear section of the chassis looks with the components that you've installed during this session.

Stage 47: The Left Headlight

In this stage you'll fit the components for the left headlight to your model's body, which you received with stage 20.



STAGE 47 PARTS LIST

Name	Name
1 Bonnet mounts	3 type A screws
2 Headlight lens	
3 Headlight housing	
4 Headlight LED	
5 Headlight cover	



Stage 47: The Left Headlight



47/01 Place the front section of the body and the bonnet mounts on a soft surface to help protect the paint work. Fit the bonnet mounts into the positions indicated, orientating them as shown in the round photo.

47/02 Screw two type A screws into the holes indicated to secure. Make sure the screws are tight.



47/03 Fit the headlight lens to the housing. The pieces only fit together one way.

47/04 There's a badge imprinted on the lens, this will help you to position the components correctly: once fitted the badge should be vertical.



Stage 47: The Left Headlight



47/05 Insert the LED light on the end of the wires into the headlight assembly, orientating the pieces exactly as shown.

47/06 Push the connector, on the other end of the wires, through the hole at the back of the left headlight recess in the body.



47/07 Continue pushing the wires through until the headlight housing reaches the headlight recess. Check that the badge on the lens is orientated as shown in the round photo.

47/08 Remove the backing from the double-sided tape on the inner edge of the headlight cover, as shown.



Stage 47: The Left Headlight



47/09 Stick the cover to the outer edge of the left headlight recess.



STAGE 47 IS COMPLETE
Here's how the front section of the body looks with the left headlight components fitted.

Stage 48: The Right Headlight

In this stage you'll fit the components for the right headlight to your model and then fit the bonnet.



STAGE 48 PARTS LIST

Name	Name
1 Headlight housing	3 type C screws
2 Headlight lens	
3 Headlight LED	
4 Headlight cover	
5 Hinge bracket	

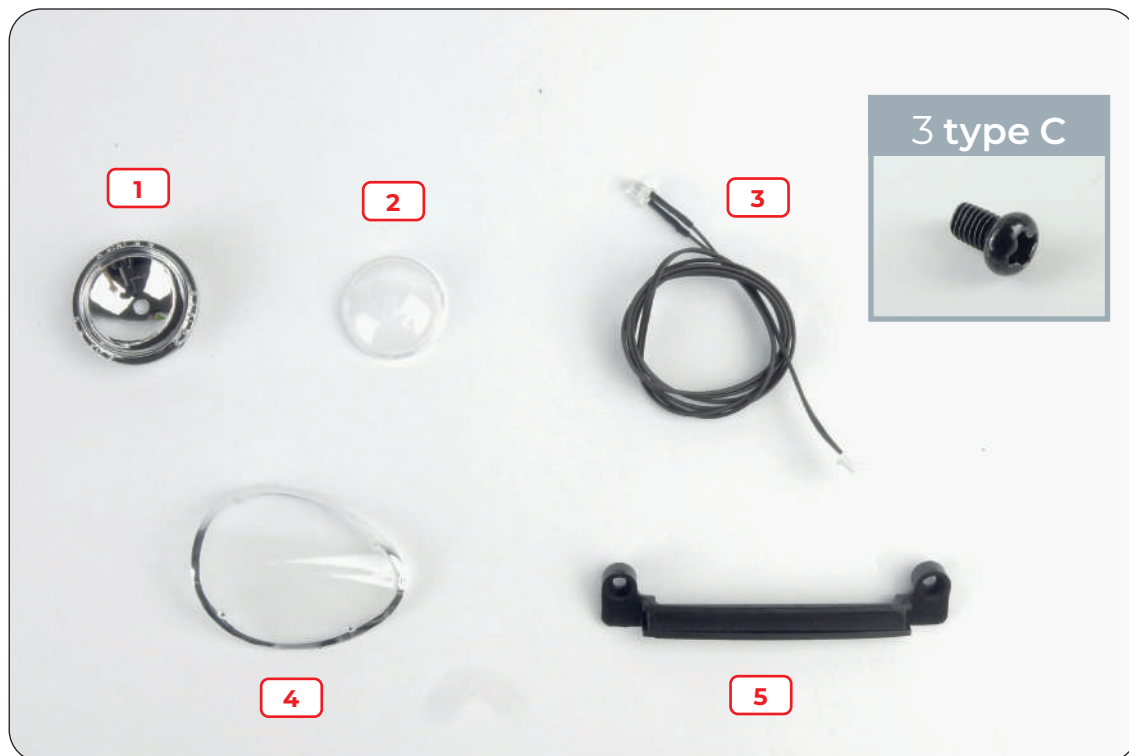

Stage 48: The Right Headlight



48/01 Fit the headlight lens to the housing. There's only one way that the pieces can be secured together. There's a badge imprinted on the lens, this will help you to position the components correctly.

48/02 Insert the LED on the end of the wires into the headlight assembly, orientating the pieces exactly as shown.

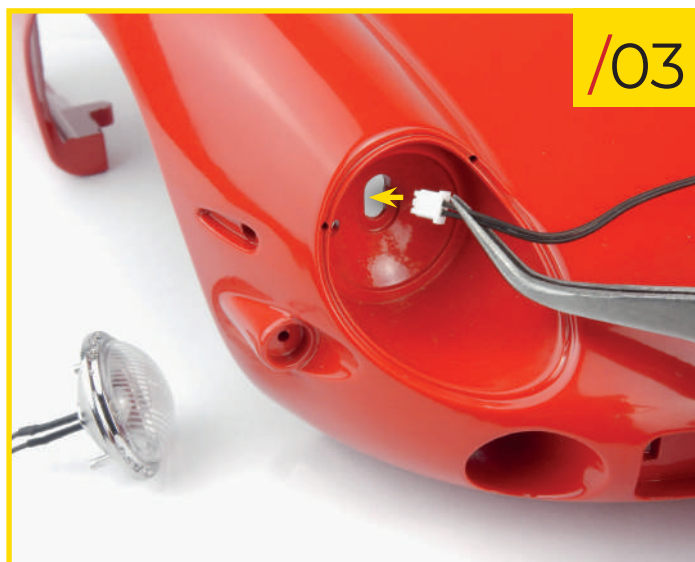

48/03 Push the connector through the hole at the back of the right headlight recess in the body.

48/04 Continue pushing the wires through until the headlight housing reaches the headlight recess. Check that the badge on the lens is orientated as shown in the round photo.

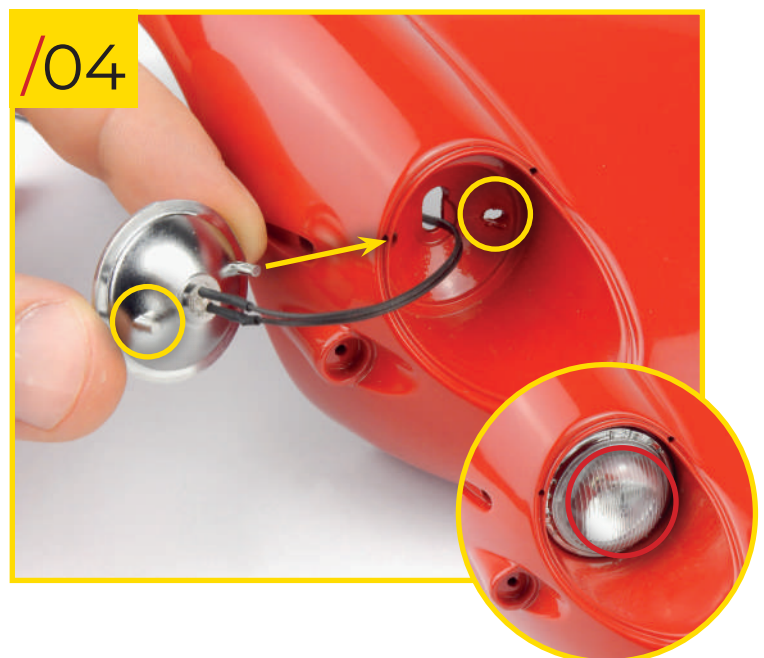

Stage 48: The Right Headlight



48/05 Remove the backing from the double-sided tape on the inner edge of the headlight cover.

48/06 Stick the cover to the front of the body.

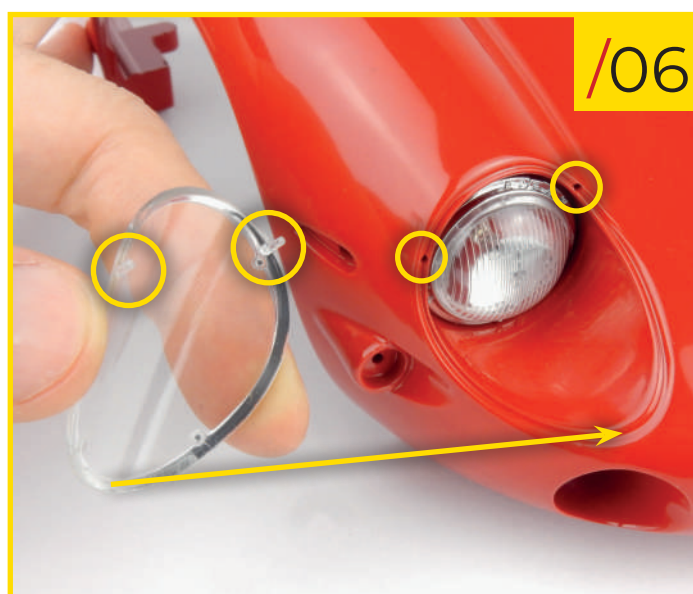

48/07 Retrieve your model's bonnet, assembled in stage 1, and fit it to the front section of the body, orientating the pieces as shown. Insert the bonnet's hinges into the fixing points shown.

48/08 Fit the bracket to the body, making sure the holes line up.



Stage 48: The Right Headlight

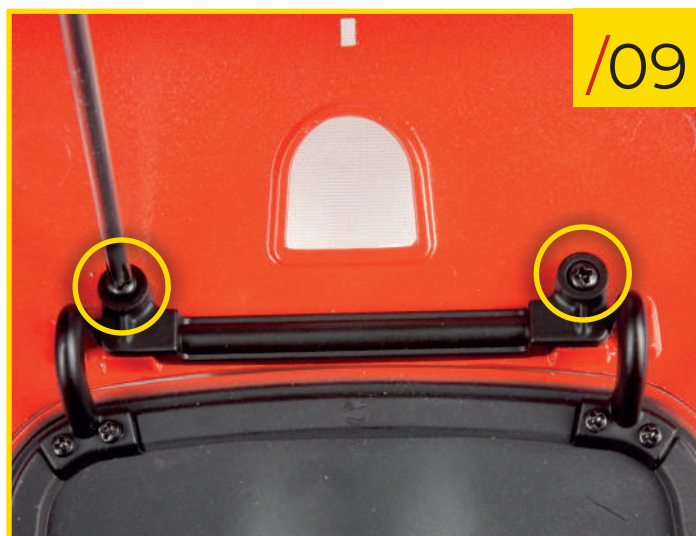

48/09 Secure the pieces together using two type C screws. Make sure the screws are tight.



STAGE 48 IS COMPLETE
Here's how the front section of the body looks at the end of this stage.