

Ferrari

250 GTO



Pack 08

BUILD INSTRUCTIONS

**STAGE 57: THE FRONT RIGHT SUSPENSION
(PART 1)**

**STAGE 58: THE FRONT RIGHT SUSPENSION
(PART 2)**

**STAGE 59: THE STEERING MECHANISM
(PART 1)**

**STAGE 60: THE STEERING MECHANISM
(PART 2)**

**STAGE 61: THE ENGINE EXHAUST
MANIFOLDS**

STAGE 62: THE FRONT LEFT INNER WING

STAGE 63: THE FRONT RIGHT INNER WING

**STAGE 64: THE FIRST SET OF
RADIATOR COMPONENTS**

Advice from the experts

To help you get the best out of building the Ferrari 250 GTO, we've prepared a modellers checklist with hints, tips and advice from our experts. The information below is aimed at making your build as enjoyable and professional as possible right from the start.

Have a soft cloth ready to place on your work surface to prevent scratching the paintwork.

Spare screws are included with each part. Occasionally, you may be instructed to keep spare or unused screws for a later stage. Keep these spares in a safe place and label them correctly.

Please make sure you don't mix up the screws. They look quite similar, but the threads do vary slightly. Using the wrong screws may damage the parts.

When securing parts together using multiple screws, fit each screw loosely to ensure all the parts are correctly aligned before gently tightening them firmly, but not overtight, in the order in which you placed them.

The screwdriver can be magnetized by stroking it with a magnet (fridge magnet, etc.) enabling it to hold the screws and make assembly easier.

If a screw is tight going into a metal part, do not force it as you may shear the head off. Remove it and put a tiny smear of Vaseline, soap or light oil on the thread. That will lubricate it and make it easier to drive home.

Only use the correct size screwdriver that fits the screw head firmly.

Use a magnet to help find screws that have fallen on the floor.

Use masking tape to hold parts temporarily in place.

Cut parts from a sprue (framework) with side cutters or a craft knife. Side cutters tend to be easiest.

During the course of this build, you will receive many pieces that you will assemble immediately – following the instructions in the corresponding stage – and other pieces that you should store safely to one side, for use in future assembly stages.

Left and Right! When building your *Ferrari 250 GTO*, the left- or right-hand side refers to that side as if you are sitting in the car.



WARNING: Some parts are assembled using magnets. These magnets can cause serious injury if they are swallowed. Keep away from children. If you suspect a magnet has been swallowed, seek medical help straight away.

All parts belong to a kit. Collectors item for adults.

Not suitable for children under 14.

Produced under license of Ferrari S.p.A. The name FERRARI, the PRANCING HORSE device, all associated logos and distinctive designs are property of FERRARI S.p.A. The body designs of the Ferrari cars are protected as Ferrari S.p.A. property under design, trademark and trade dress regulations.

Stage 57: The Front Right Suspension (Part 1)

In this stage you'll start assembling the components for the front right suspension.



STAGE 57 PARTS LIST

Name	Name
1 Stub axle	2 type C screws
2 Upper arms	2 type J screws
3 Shock absorber	

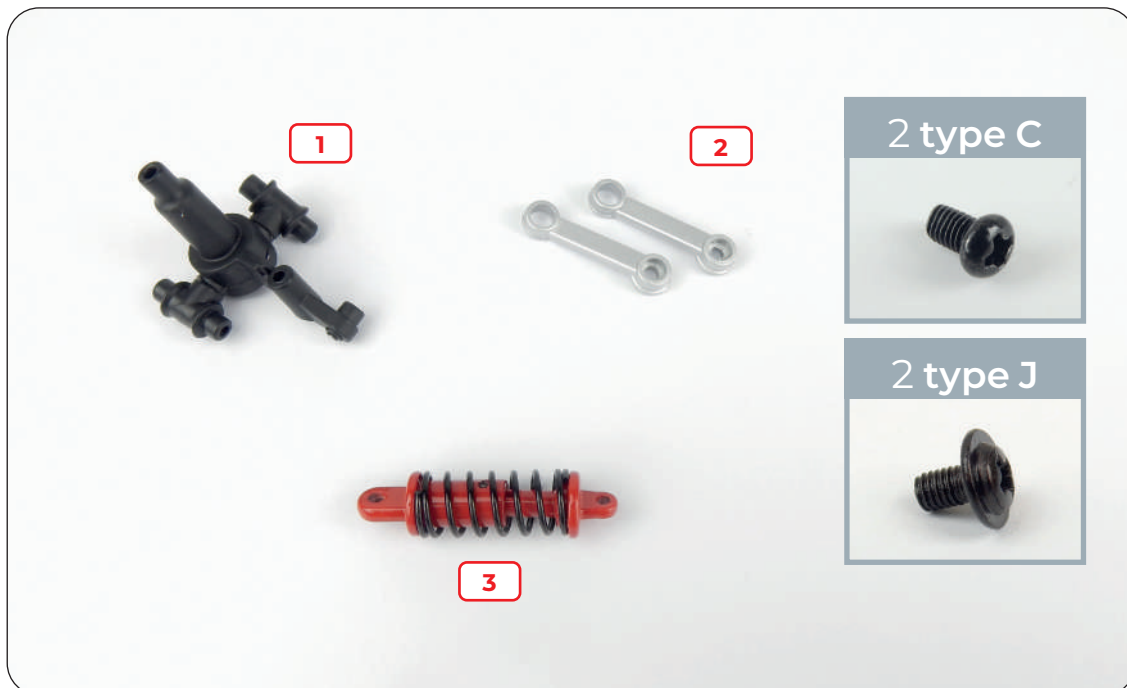

Stage 57: The Front Right Suspension (Part 1)

/01

57/01 Fit one of the upper arms to the stub axle, orientating the pieces as shown. Use the stud highlighted by the circle in the photo as a reference. The holes at the ends of the arms aren't identical: for this step you'll need to use the end with the larger hole (shown in the round photo). Secure the pieces together using a type J screw.



/02

57/02 Fit the second upper arm to the stub axle, being very careful to ensure you orientate the pieces as shown in the photo.



Stage 57: The Front Right Suspension (Part 1)

/03



57/03 Now fit the shock absorber to the rest of the assembly, orientating the pieces as shown. Secure everything together using a type C screw.



STAGE 57 IS COMPLETE
Here's how the front right suspension looks at the end of this assembly session.

Stage 58: The Front Right Suspension (Part 2)

In this stage you'll continue assembling your model's front right suspension.



STAGE 58 PARTS LIST

Name	Name
1 Connecting mount	6 Fork bracket
2 Spring	
3 Spring support	5 type B screws
4 Lower arm B	2 type C screws
5 Lower arm A	3 type J screws



Stage 58: The Front Right Suspension (Part 2)



58/01 Place the front right suspension assembly you worked on in stage 57 and the connecting mount on your work surface. Orientate the pieces as shown and secure them together by screwing two type B screws into the holes indicated.

58/02 Slide one end of the spring over the central stud on the mount and push the spring support into the other end of the spring.

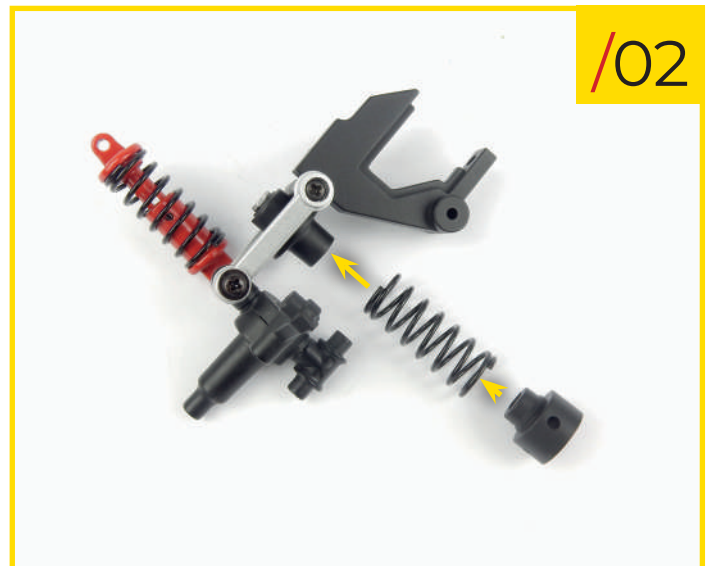

58/03 Connect the lower arm B (the one without a central hole) to the rest of the assembly, orientating the pieces as shown. Line up the longer end of the arm with the mount, and the shorter end with the stub axle, then insert the stud on the centre of the arm into one of the holes in the spring support. Screw a type B screw into the hole indicated by a circle in the photo.

Stage 58: The Front Right Suspension (Part 2)

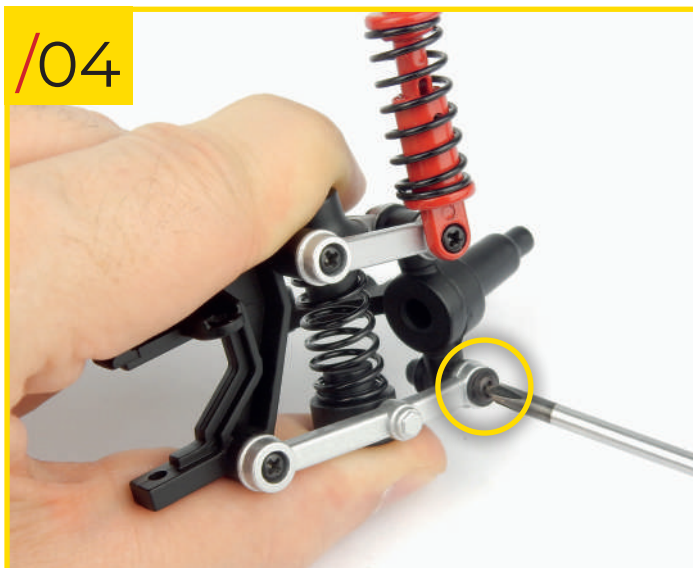

58/04 Secure the arm to the stub axle using a type J screw.

58/05 Working on the other side of the assembly, fit the lower arm A. Ensure the longer end of the arm goes towards the mount, and the shorter end towards the stub axle, then insert the stud on the centre of the arm into the second side hole in the spring support. Screw a type B screw into the hole indicated.

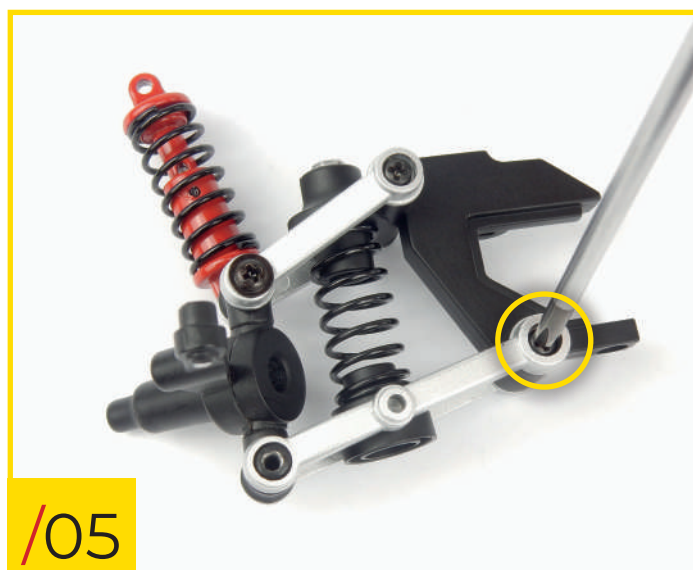

58/06 Screw a type J screw into the hole indicated to secure the arm to the stub axle.

Stage 58: The Front Right Suspension (Part 2)



58/07 Finally, position the fork bracket so that it lines up with the arm's central hole, then secure the pieces together using a type C screw.



STAGE 58 IS COMPLETE
Here's how the front right suspension assembly looks at the end of this session. Keep it somewhere safe together with the other pieces.

Stage 59: The Steering Mechanism (Part 1)

In this stage you'll start working on your model's steering. Keep the parts you don't use during this session in a safe place, you'll need them for a subsequent stage.



STAGE 59 PARTS LIST

Name	Name
1 Idler arm	6 Steering box insert
2 Pitman arm	7 Tie rods
3 Centre link	
4 Steering box mount	7 type B screws
5 Steering box	9 type J screws



Stage 59: The Steering Mechanism (Part 1)

/01



59/01 Place the centre link, idler arm and pitman arm on your work surface, orientating them as shown. Fit the pieces together by inserting the studs on the arms into the respective holes in the centre link.

59/02 Secure the pieces together using two type J screws.



/02

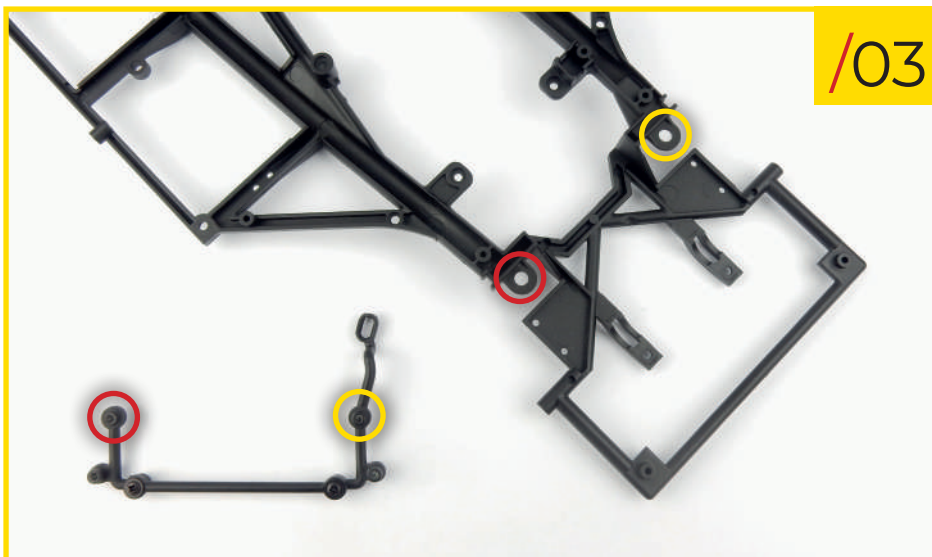

/03

59/03 Retrieve your model's chassis, orientate it as shown and fit the steering assembly to it. The circles in the photo show which studs on the arms need to go into which holes in the chassis.

Stage 59: The Steering Mechanism (Part 1)

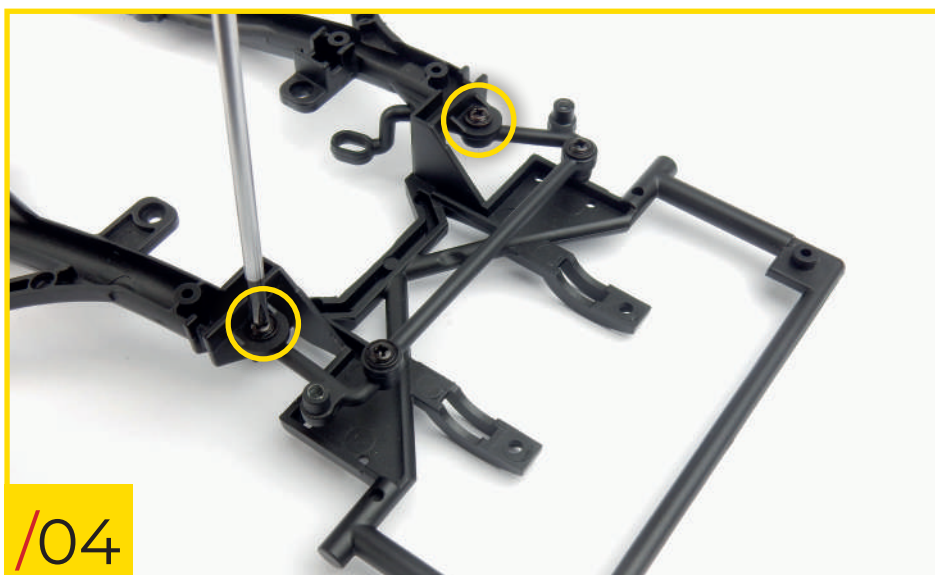

59/04 Secure the arms to the chassis by screwing two type J screws into the holes indicated in the photo.

/04

59/05 Retrieve the front right suspension (assembled in stages 57 and 58) and fit it to the chassis, orientating the pieces as shown. Screw a type B screw into the hole indicated in the second photo.

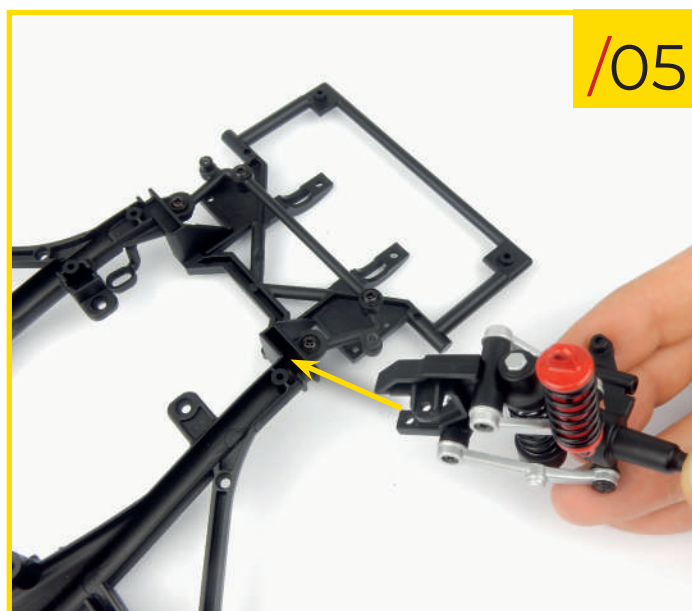

/05

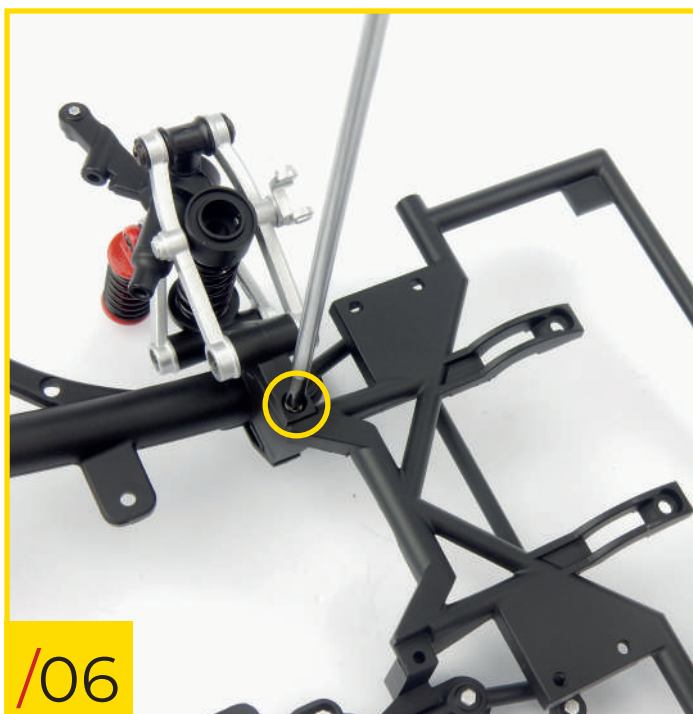

/06

59/06 Turn the chassis upside down and screw a second type B screw into the indicated hole on the underside.

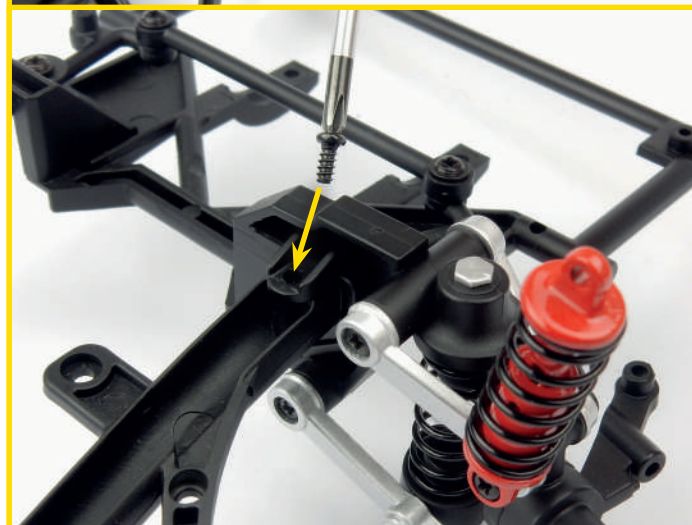

Stage 59: The Steering Mechanism (Part 1)



59/07 Fit the steering box to its mount, orientating the components as shown. Secure the pieces together using a type B screw.

59/08 Retrieve the front left suspension (assembled in stages 55 and 56) and fit the steering box assembly to it. Secure the pieces together using a type B screw.

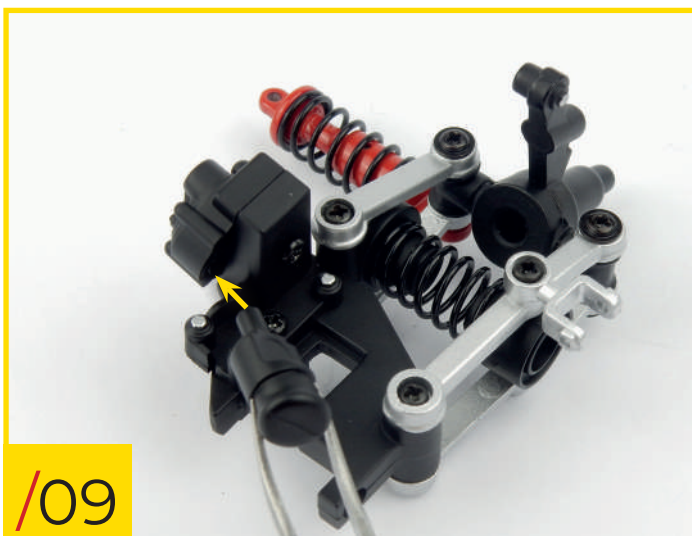
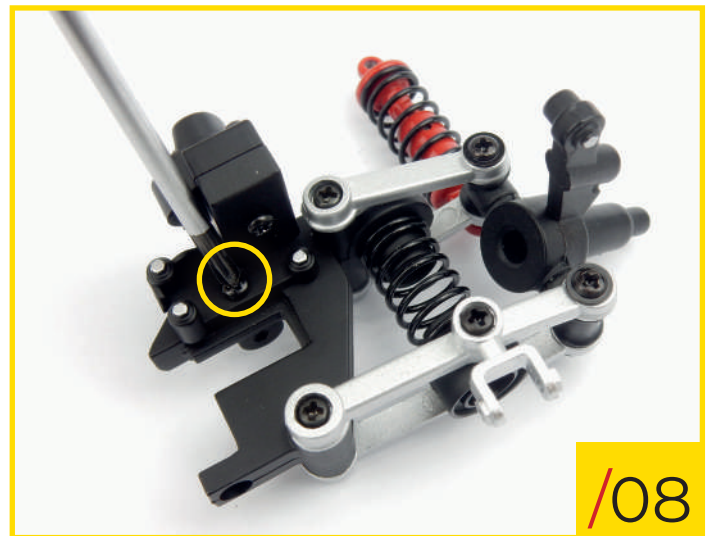

59/09 Fit the steering box insert to the steering box.

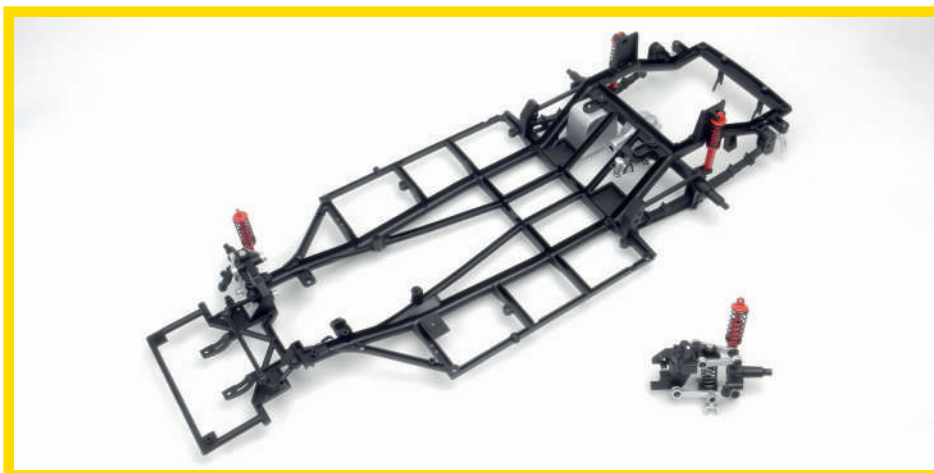

STAGE 59 IS COMPLETE
Here's how your model's chassis and front left suspension look at the end of this assembly phase. Keep the parts you haven't used in a safe place, you'll need them later.

Stage 60: The Steering Mechanism (Part 2)

In this stage you'll continue working on your model's steering mechanism, using the pieces from stage 59 as well as those supplied in this stage.



STAGE 60 PARTS LIST

Name	Name
1 Steering shaft	2 type B screws
2 Mounting plate	

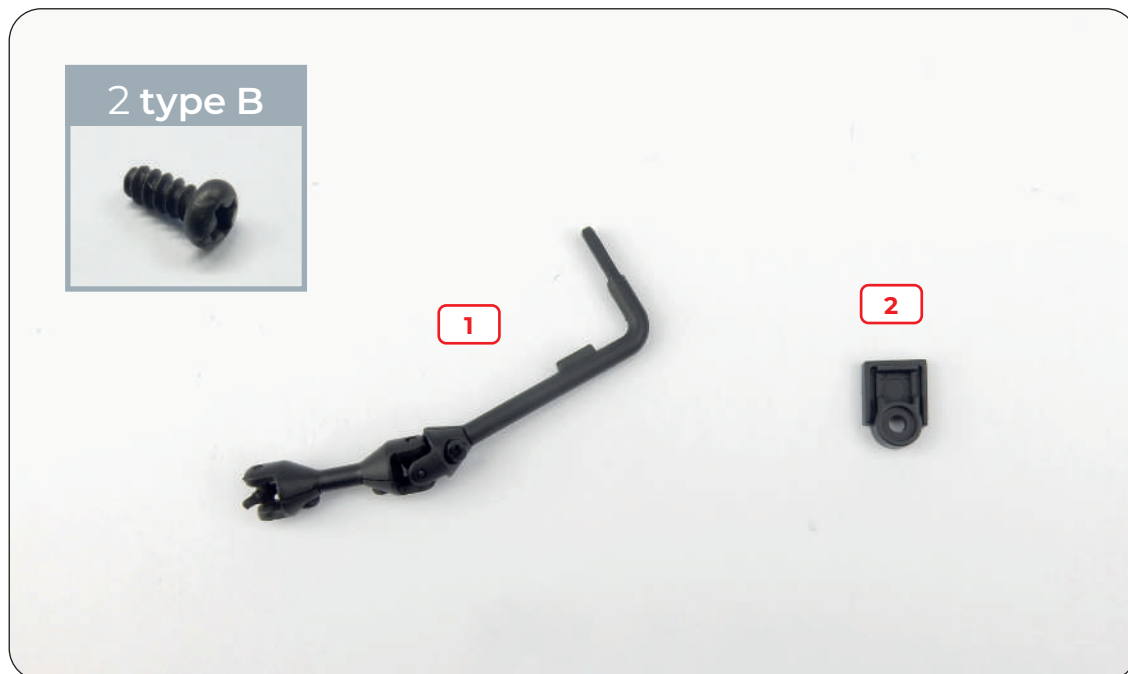

Stage 60: The Steering Mechanism (Part 2)

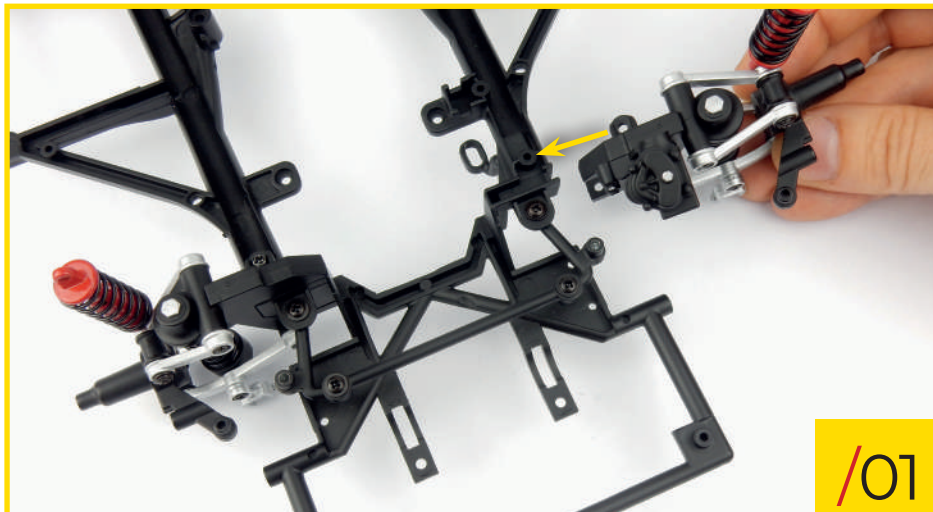

60/01 Retrieve the front left suspension and chassis from stage 59. Fit the pieces together, orientating them as shown.

/01

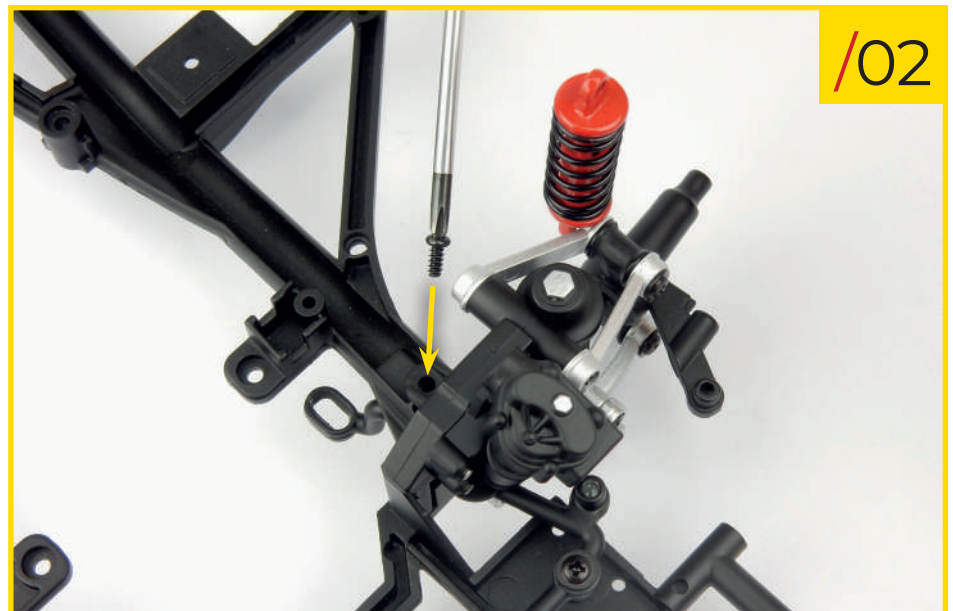

60/02 Screw a type B screw (supplied with stage 59) into the hole indicated in the photo.

/02

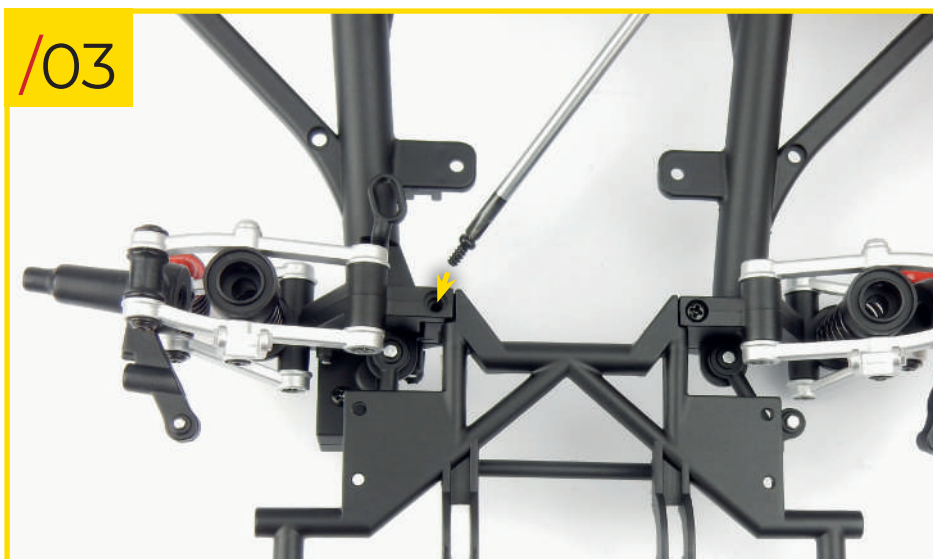

60/03 Turn the chassis upside down and screw a second type B screw (supplied with stage 59) into the hole indicated in the photo. Tighten the screw to ensure the suspension is securely fitted to the chassis.

/03

Stage 60: The Steering Mechanism (Part 2)

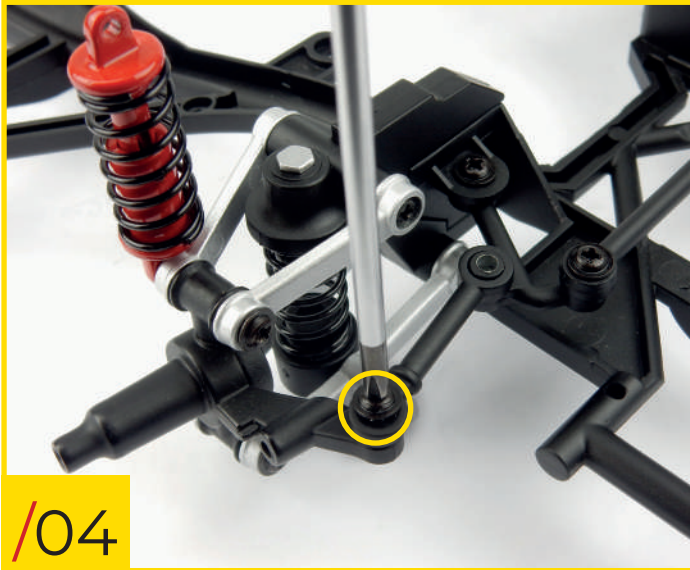

60/04 Connect the front right suspension's stub axle to the right arm using one of the tie rods supplied with stage 59. Orientate the tie rod as shown and secure it to the stub axle using a type J screw (supplied with stage 59). You will need to compress the suspension to fit the tie rod.

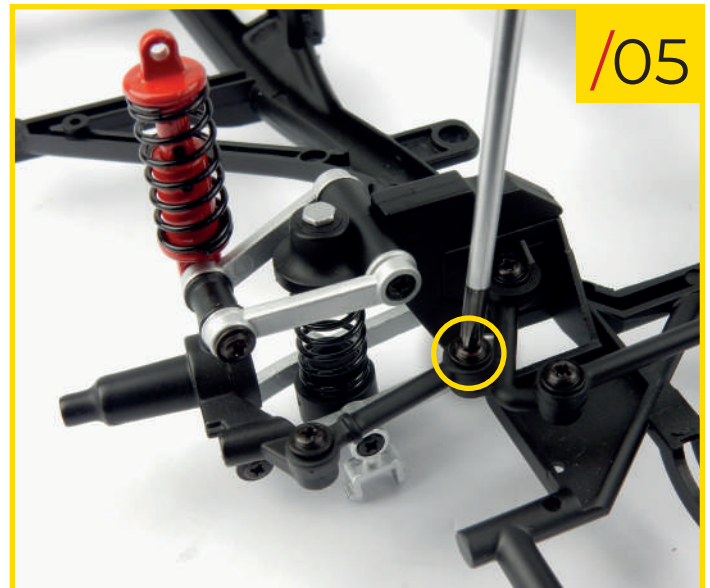

60/05 Screw a second type J screw (supplied with stage 59) into the hole indicated to fit the tie rod to the idler arm.



60/06 Follow the same process for the left side: connect the arm and stub axle using the second tie rod (stage 59) and secure the pieces together by screwing two type J screws (stage 59) into the holes indicated.



60/07 Fit the steering shaft to the chassis and the pitman arm, orientating the pieces as shown.

Stage 60: The Steering Mechanism (Part 2)

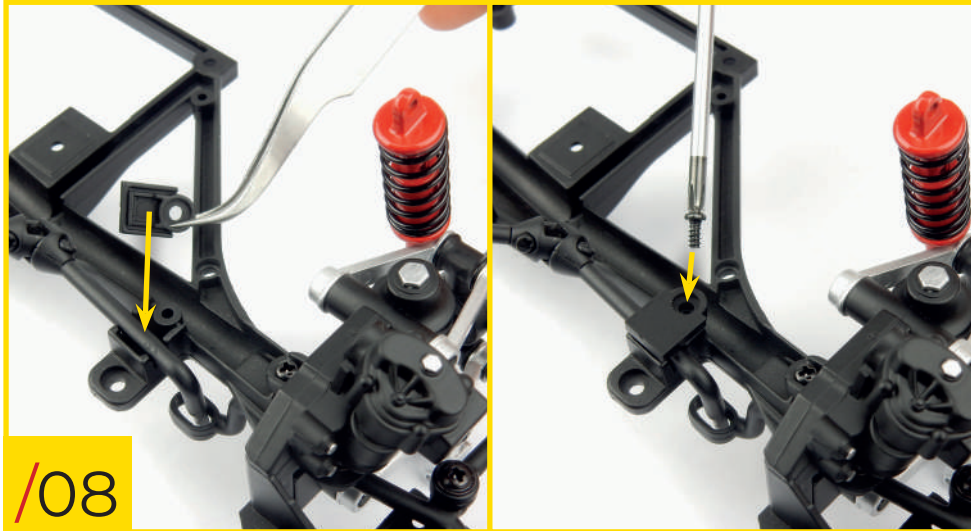

60/08 Fit the mounting plate to the chassis and secure it in place using a type B screw.

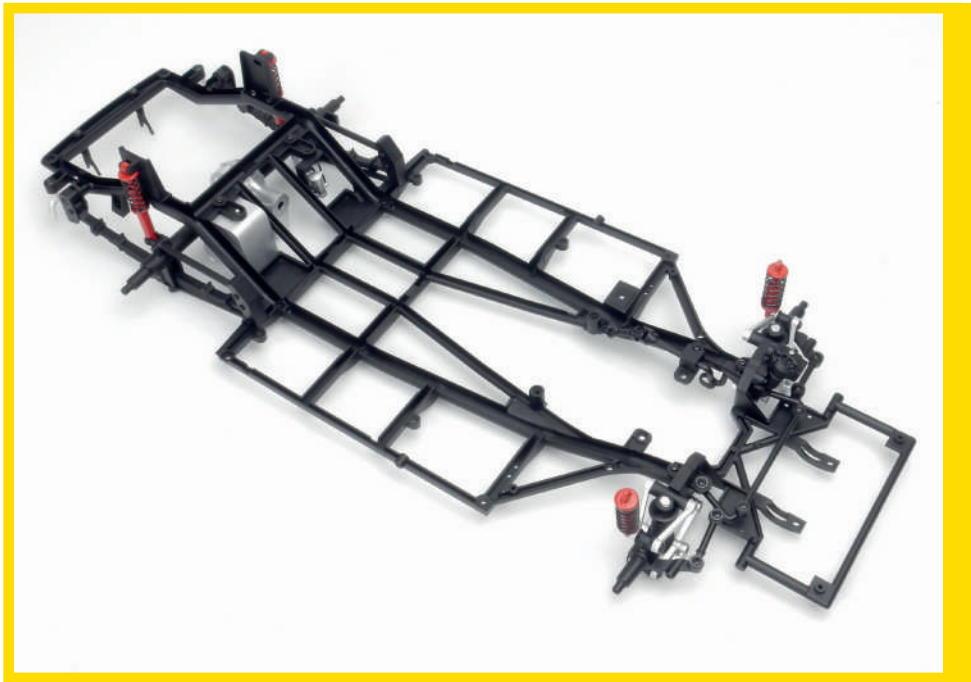

STAGE 60 IS COMPLETE
Here's how your model's chassis looks with the steering components correctly fitted.

Stage 61: The Engine Exhaust Manifolds

In this stage you'll add the engine to your model's chassis and fit the engine's exhaust manifolds.



STAGE 61 PARTS LIST

Name
1 Front left exhaust manifolds
2 Front right exhaust manifolds
3 Rear left exhaust manifolds
4 Rear right exhaust manifolds
5 type C screws



Stage 61: The Engine Exhaust Manifolds

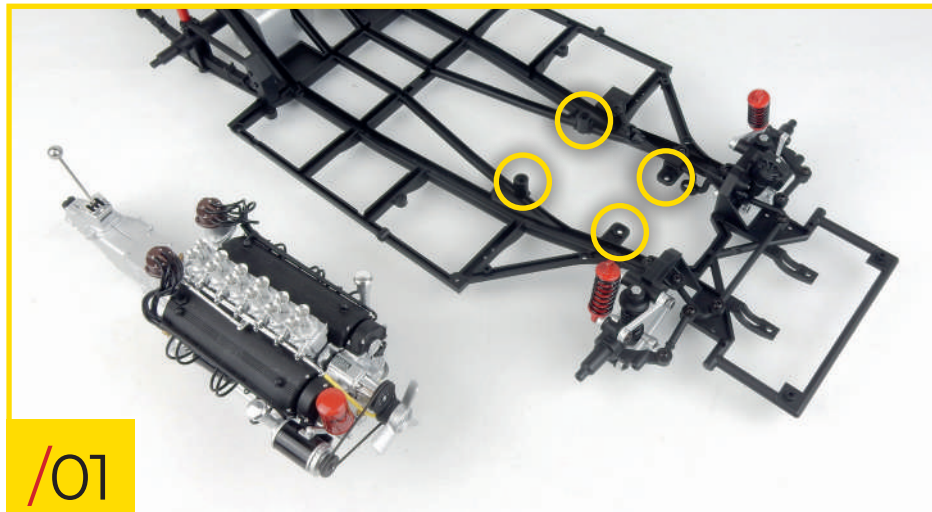

61/01 Place your model's engine and chassis on your work surface. Look at the photo carefully to identify the holes and mounts (indicated by the circles) that you'll need for fitting the engine.

/01

61/02 Fit the engine to the chassis, orientating the pieces as shown.

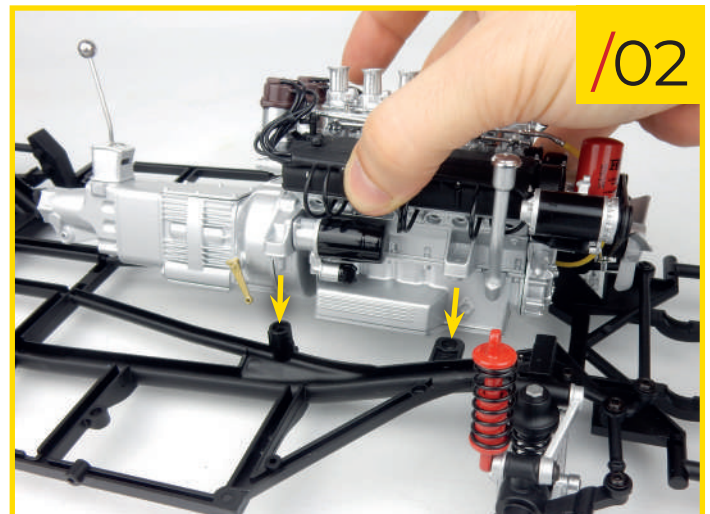

/02



/03

61/03 Turn the assembly over and secure the pieces together using four type C screws.

61/04 Now place the right-side exhaust manifolds on your work surface.

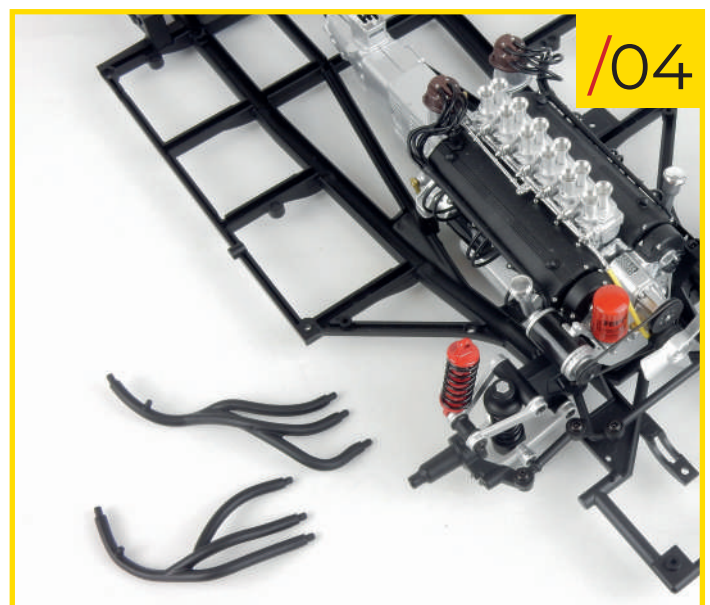

/04

Stage 61: The Engine Exhaust Manifolds

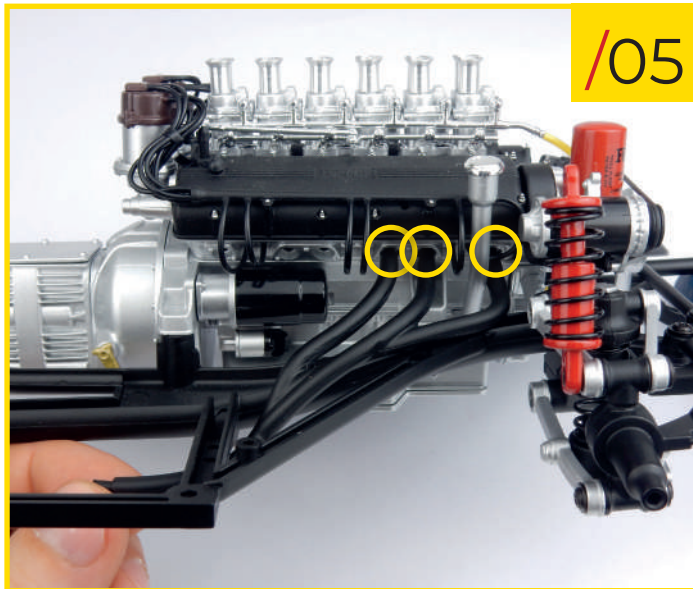

/05

61/05 Fit the front right exhaust manifolds to the engine, orientating the pieces as shown.

61/06 Insert the stud on the end of the front exhaust manifolds into the corresponding hole in the chassis.

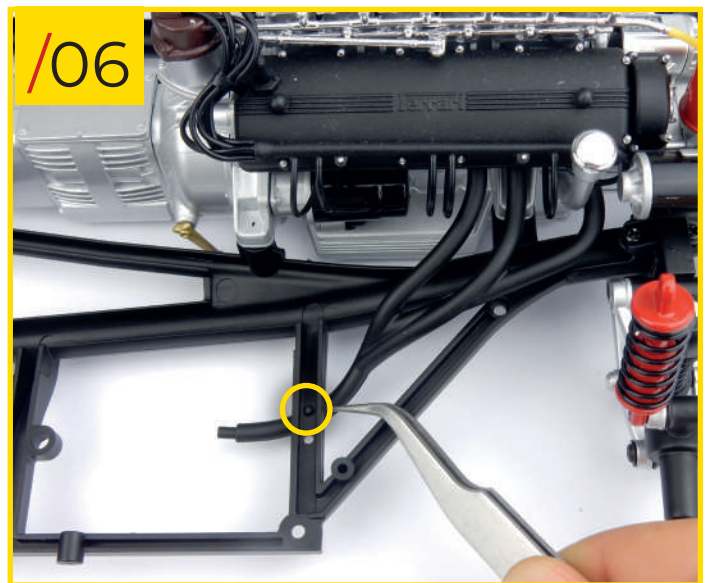

/06

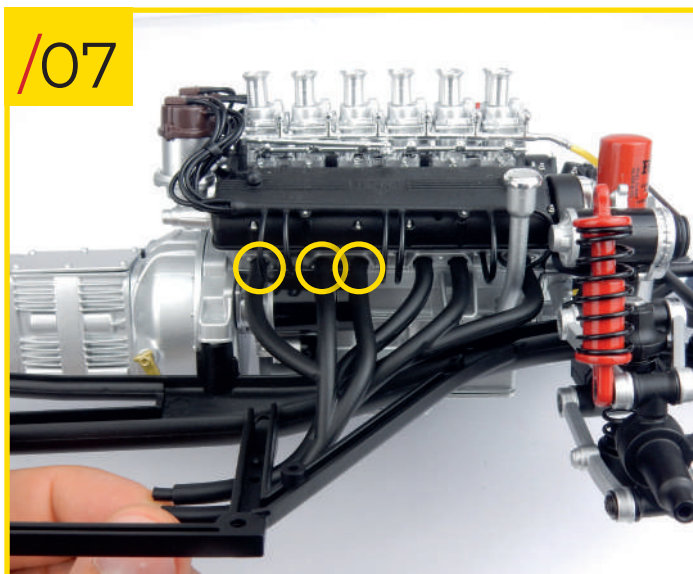

/07

61/07 Now fit the rear right exhaust manifolds to the engine.

61/08 Insert the stud on the end of the rear exhaust manifolds into the corresponding hole in the chassis, as shown.

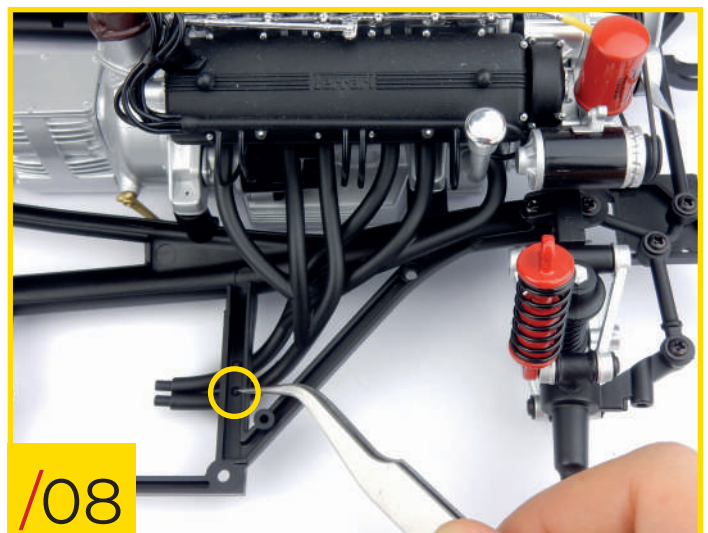

/08

Stage 61: The Engine Exhaust Manifolds

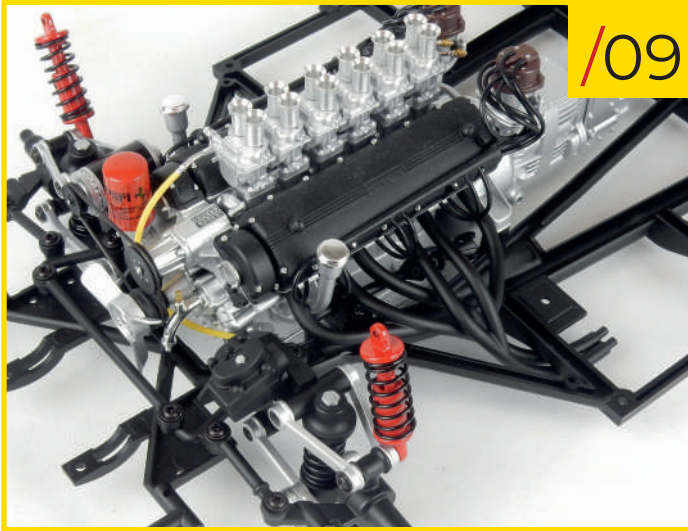

61/09 Repeat the previous steps to fit the left-side exhaust manifolds.

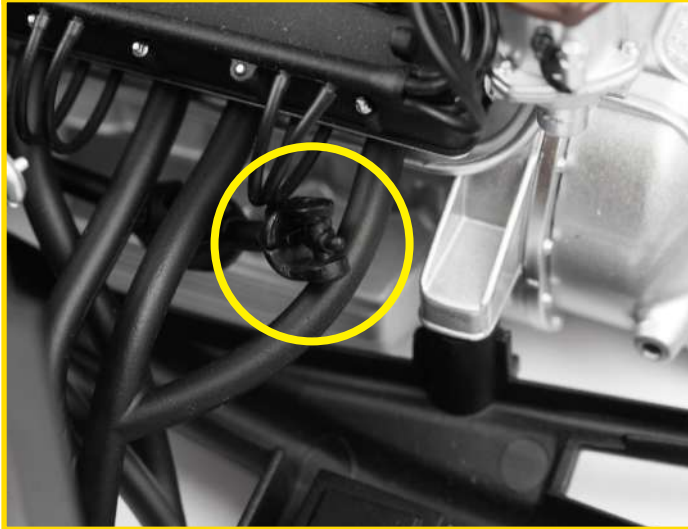

Make sure the end of the steering shaft passes between the exhaust manifolds as shown in the bottom image.

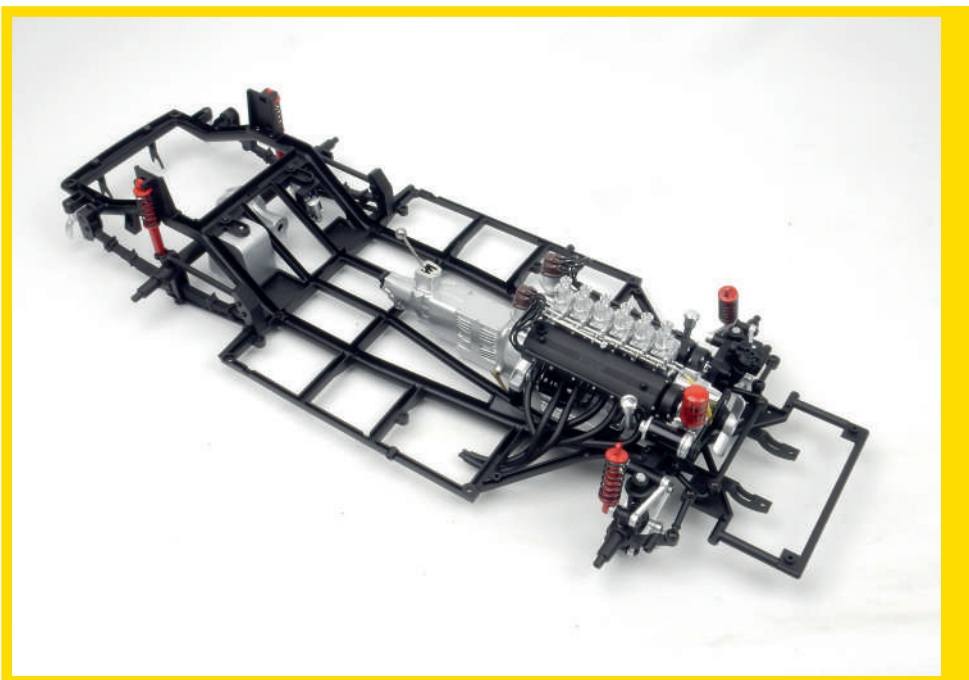

STAGE 61 IS COMPLETE
Here's how your model's chassis looks with the engine and exhaust manifolds correctly fitted.

Stage 62: The Front Left Inner Wing

In this stage you'll fit the front left inner wing to your model's chassis.



STAGE 62 PARTS LIST

Name	Name
1 Front left inner wing	5 type B screws
2 Left shock absorber bracket	2 type G screws

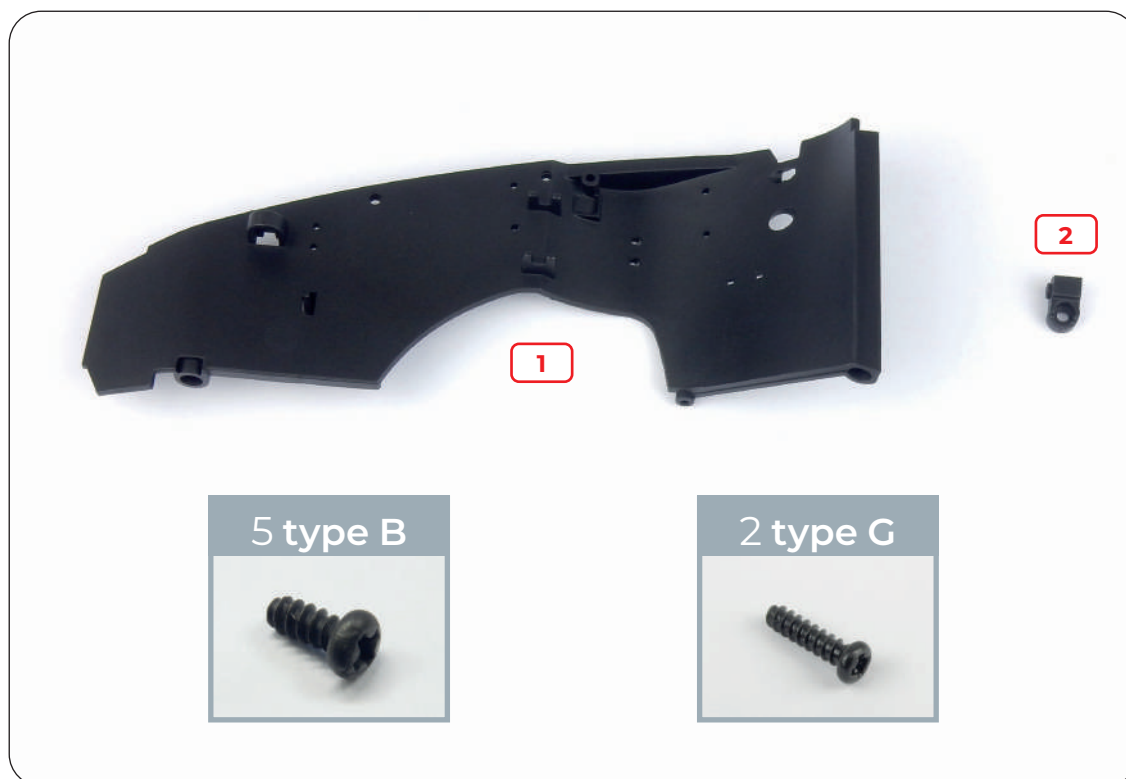

Stage 62: The Front Left Inner Wing

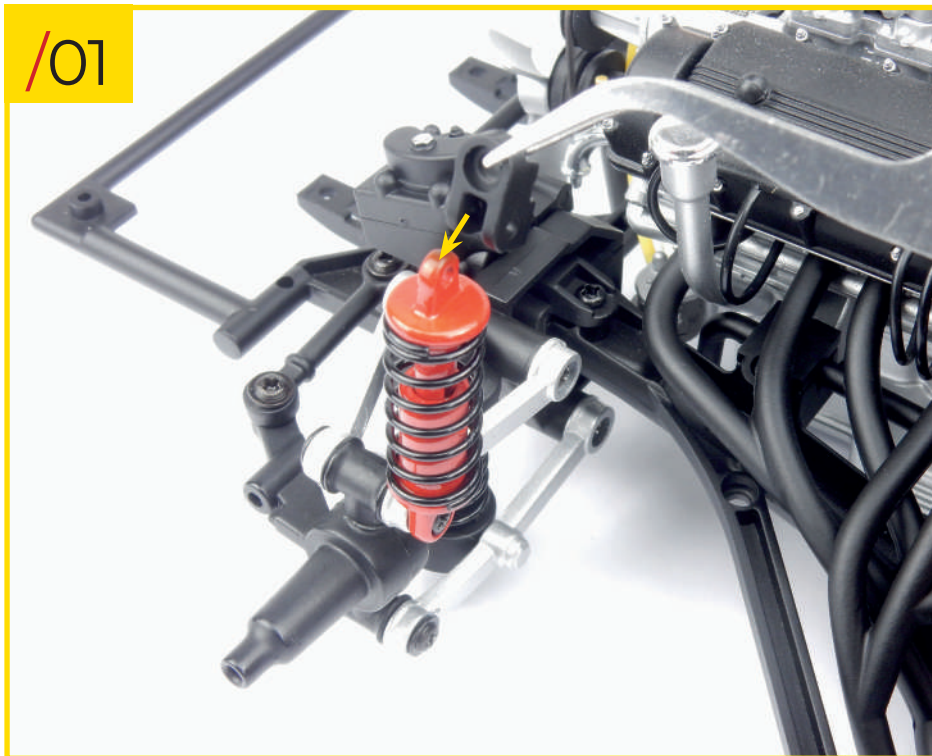

62/01 Fit the bracket to the front left shock absorber. Orientate the pieces as shown in the photo.

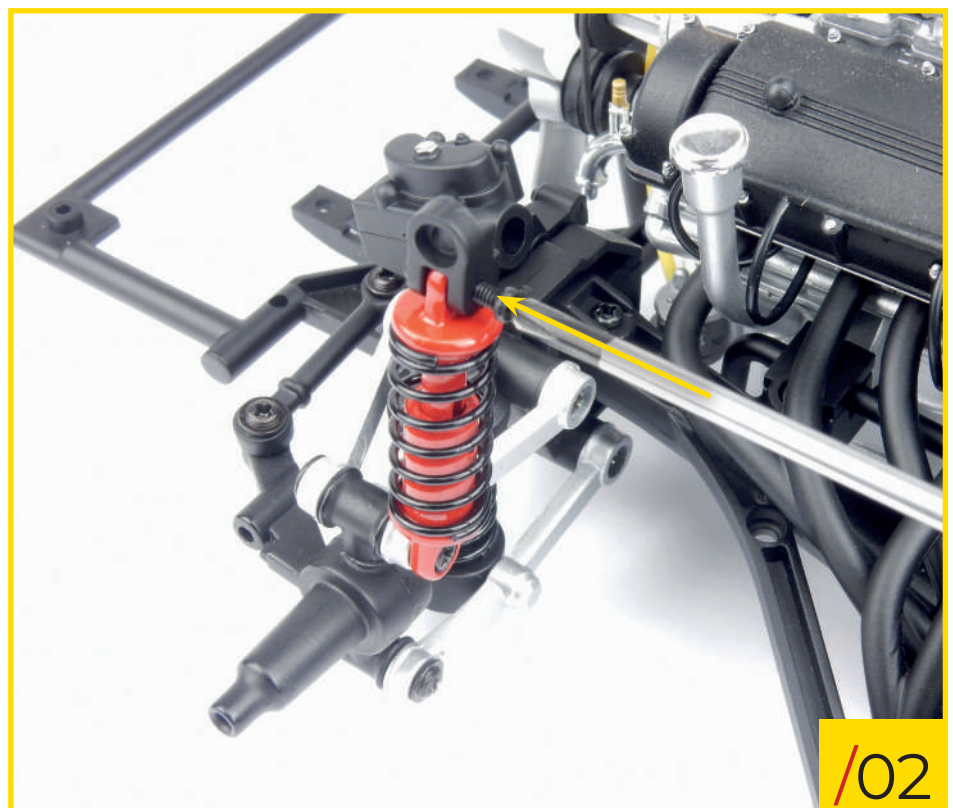

62/02 Secure the bracket to the shock absorber using a type G screw.

Stage 62: The Front Left Inner Wing

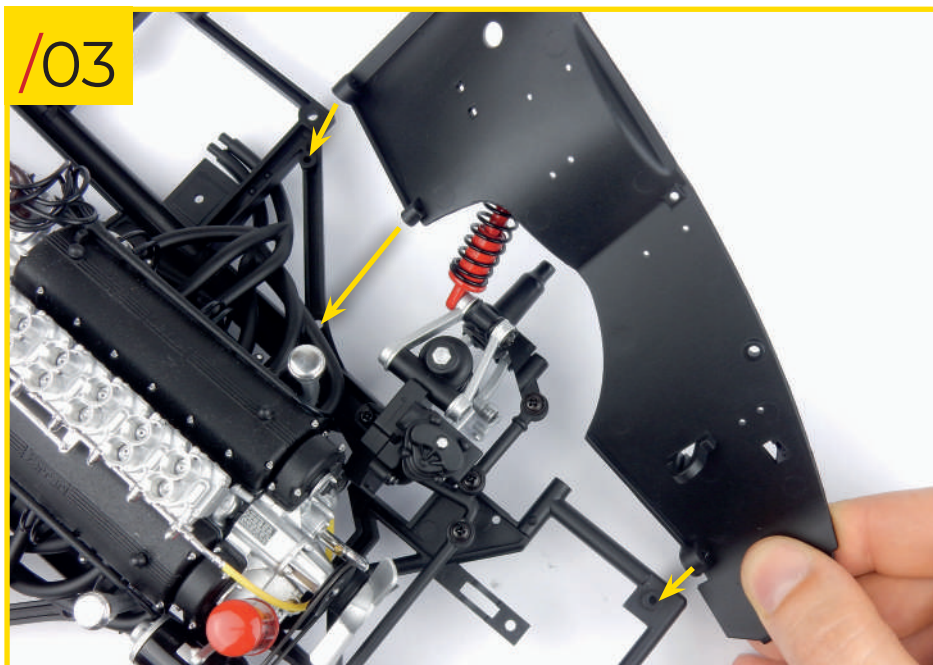

62/03 Fit the front left inner wing to the chassis, orientating the pieces as shown.

62/04 Start to secure the inner wing by screwing two type B screws into the holes indicated.

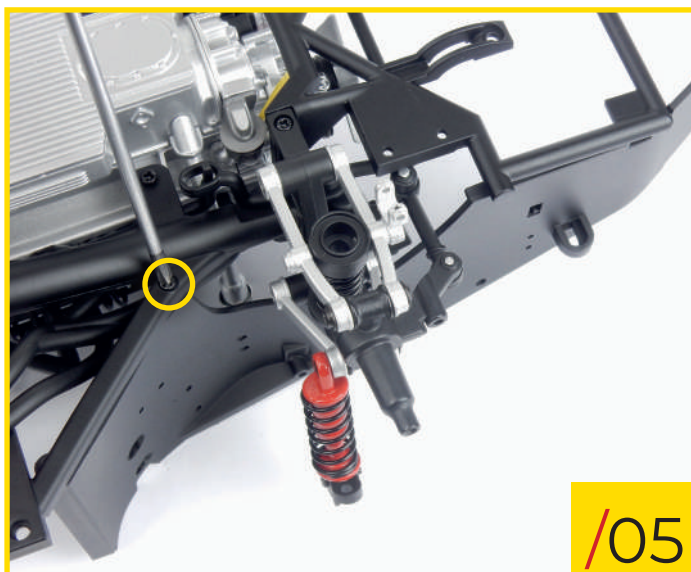
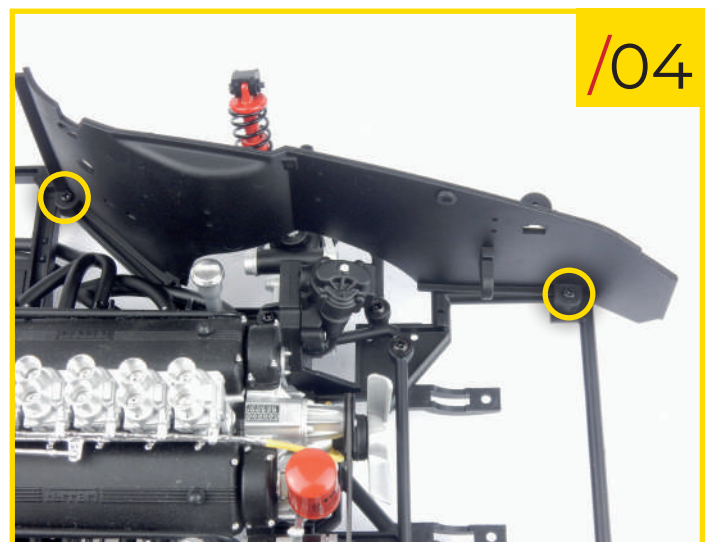

62/05 Turn the assembly over and finish securing by screwing a third type B screw into the hole indicated.

Stage 62: The Front Left Inner Wing

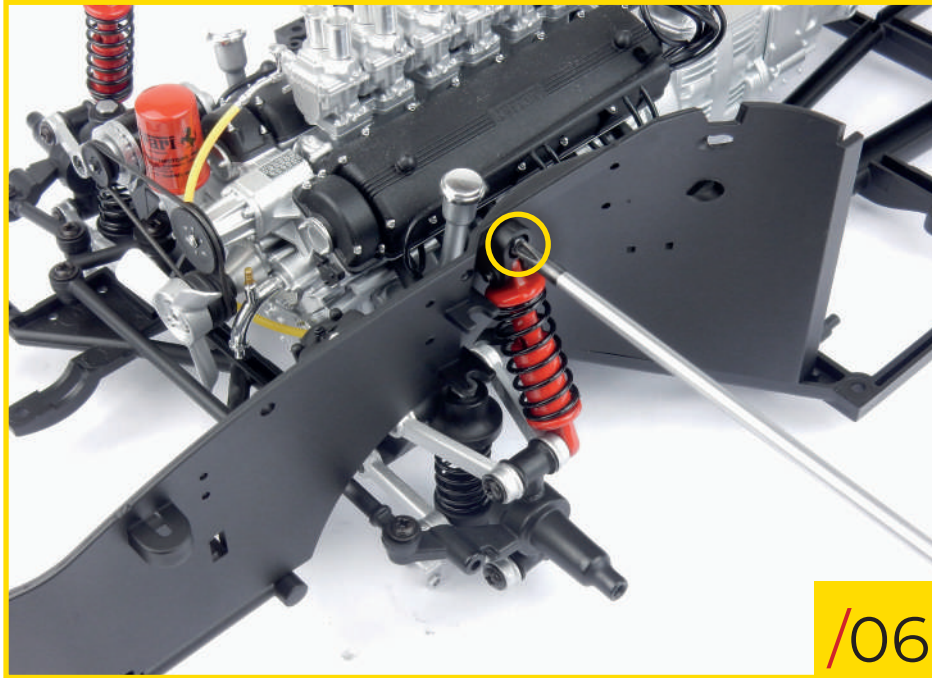

62/06 Secure the left shock absorber bracket to the inner wing with another type B screw.

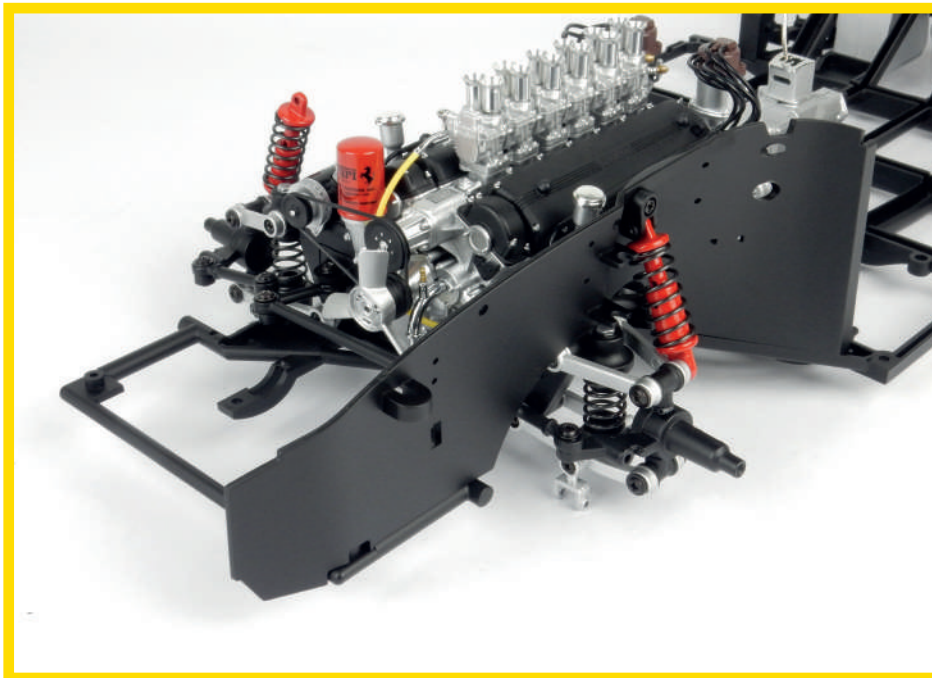

STAGE 62 IS COMPLETE
Here's how the front left inner wing looks after it's been fitted to your model's chassis.

Stage 63: The Front Right Inner Wing

In this stage you'll fit the front right inner wing to your model's chassis.



STAGE 63 PARTS LIST

Name	Name
1 Right shock absorber bracket	5 type B screws
2 Front right inner wing	2 type G screws

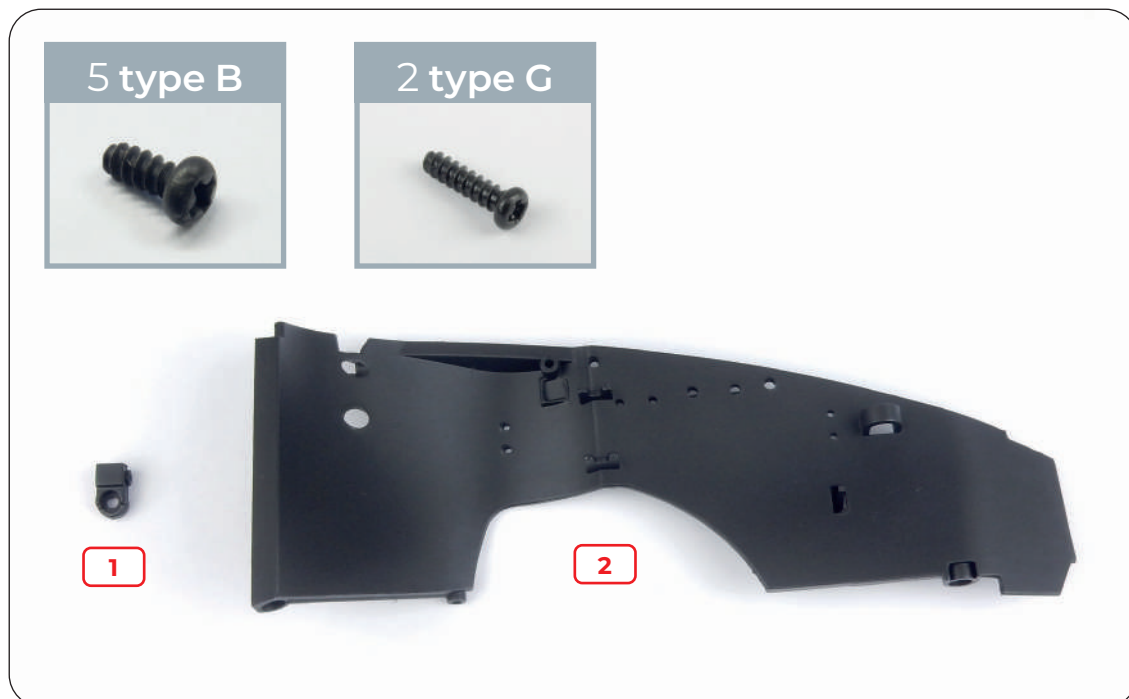

Stage 63: The Front Right Inner Wing

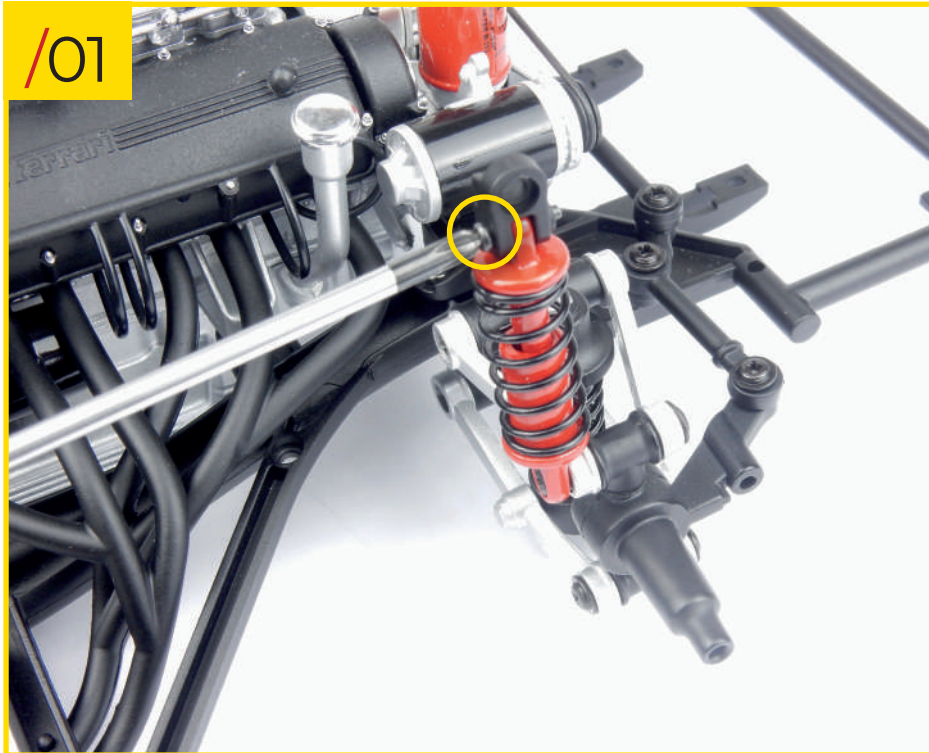

63/01 Fit the bracket to the front right shock absorber. Orientate the pieces as shown in the photo and secure them together using a type G screw.

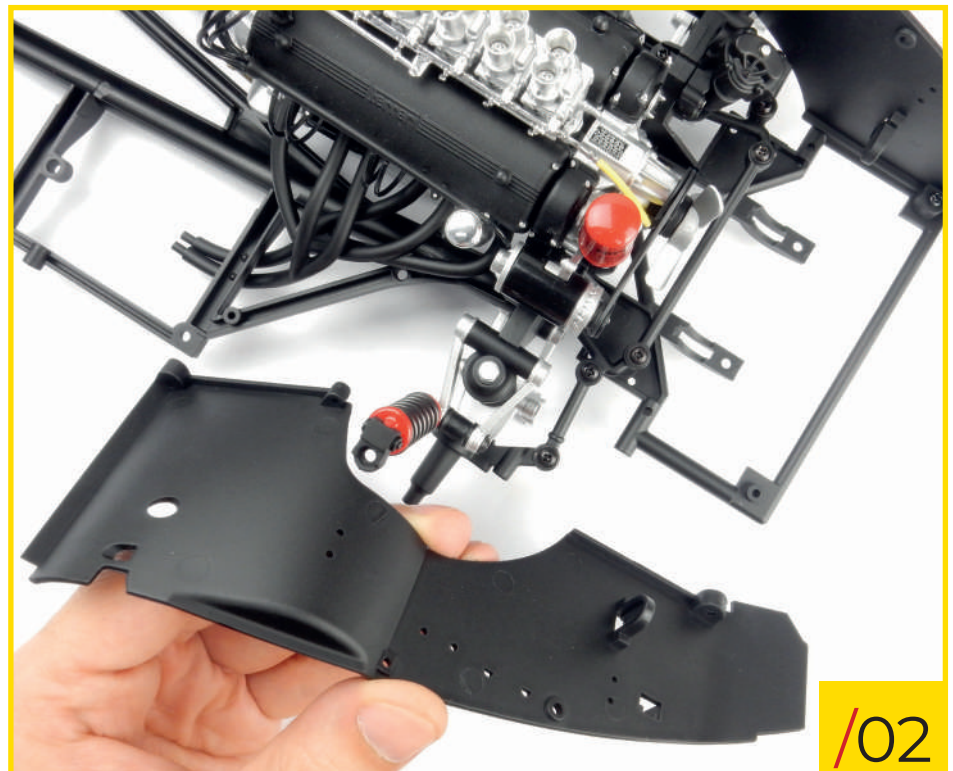

63/02 Fit the front right inner wing to the chassis, orientating the pieces as shown.

Stage 63: The Front Right Inner Wing

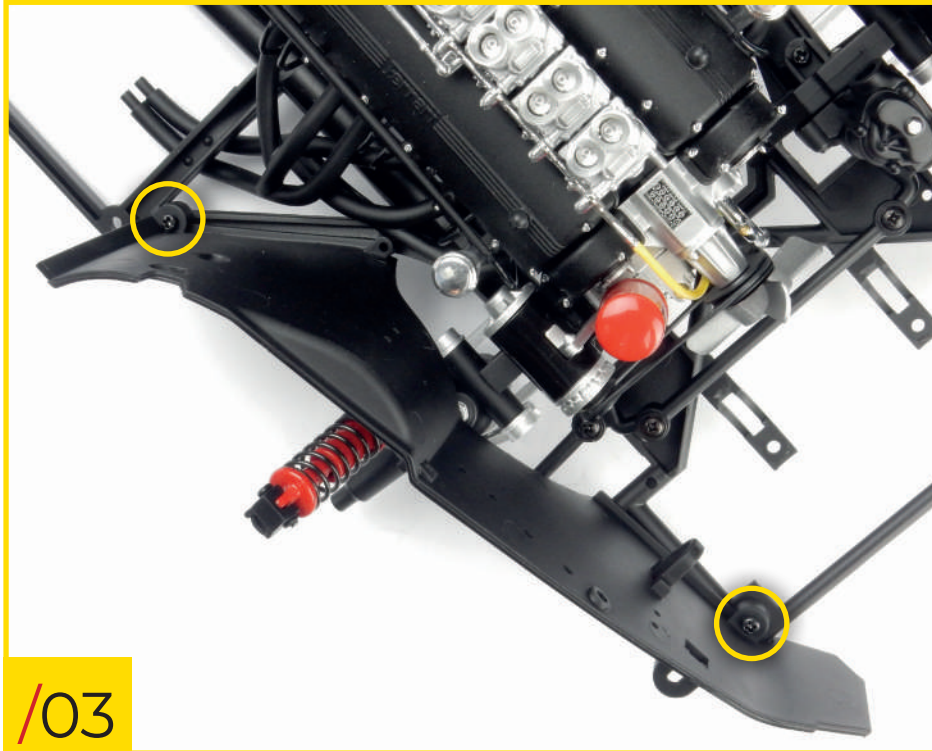

63/03 Start to secure the inner wing by screwing two type B screws into the holes indicated.

/03

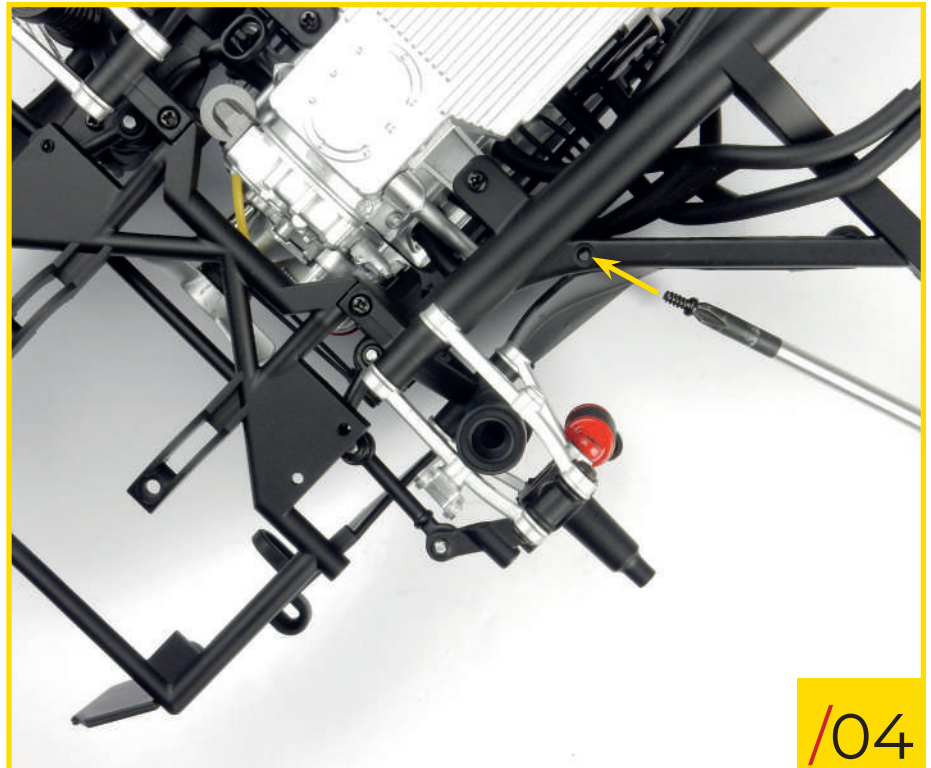

63/04 Turn the assembly over and finish securing by screwing a third type B screw into the hole indicated.

/04

Stage 63: The Front Right Inner Wing

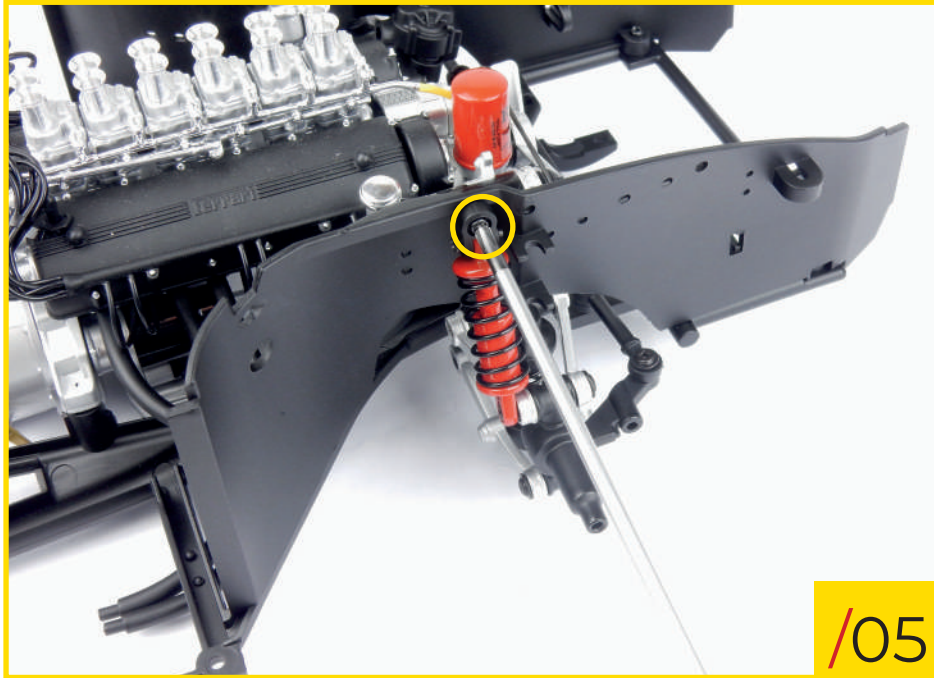

/05

63/05 Secure the right shock absorber bracket to the inner wing with another type B screw.

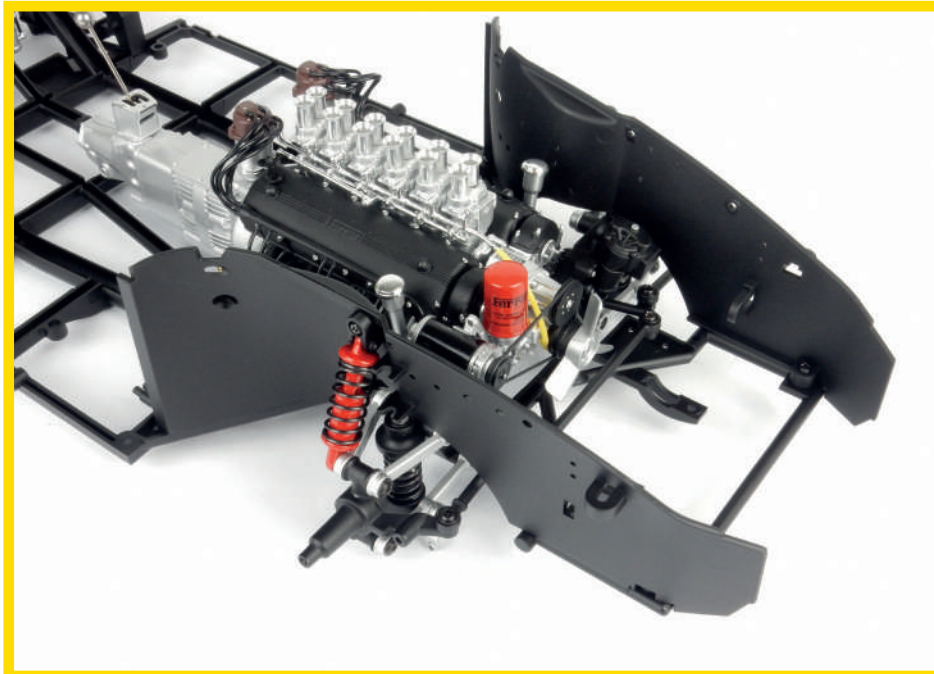

STAGE 63 IS COMPLETE
Here's how your model's chassis looks with both the front inner wings fitted.

Stage 64: The First Set of Radiator Components

In this stage you'll install the first set of radiator components, as well as the speaker, to your model's chassis.



STAGE 64 PARTS LIST

Name	Name
1 Speaker	5 Speaker housing panel
2 Radiator cap	6 Radiator back panel
3 Radiator header	
4 Locking ring	7 type B screws



Stage 64: The First Set of Radiator Components

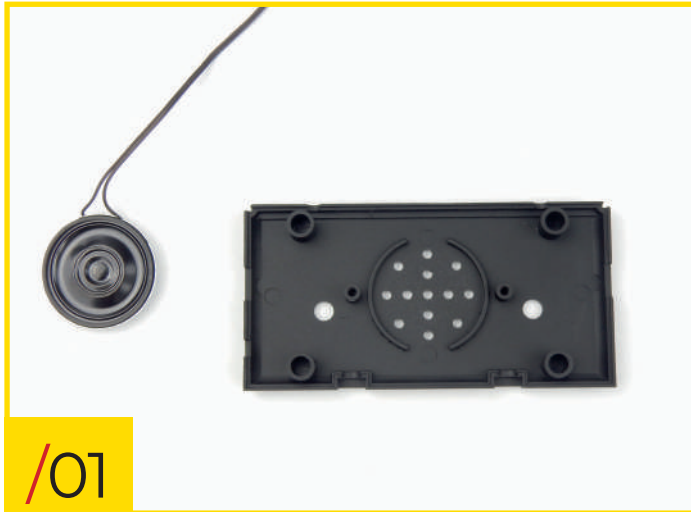

64/01 Place the speaker and its housing panel on your work surface. The centre of the panel is the speaker housing.

64/02 Place the speaker into the housing, orientating the pieces as shown in the photo. Make sure to place the cable in the gap of the circular housing.

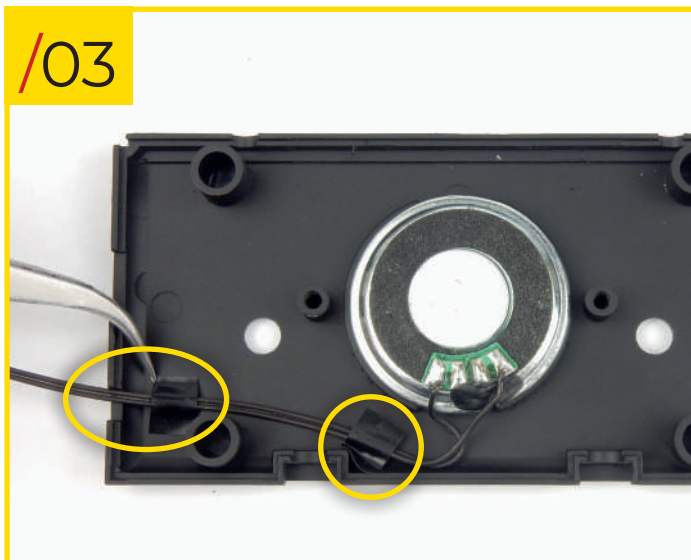

64/03 Position the speaker cable as shown, to ensure it exits from the side of the housing panel. To avoid damaging the cable during the assembly process, we recommend taping it to the panel as indicated in the photo.

64/04 Fit the locking ring to the inner face of the housing panel by placing it over the speaker and orientating the pieces as shown.

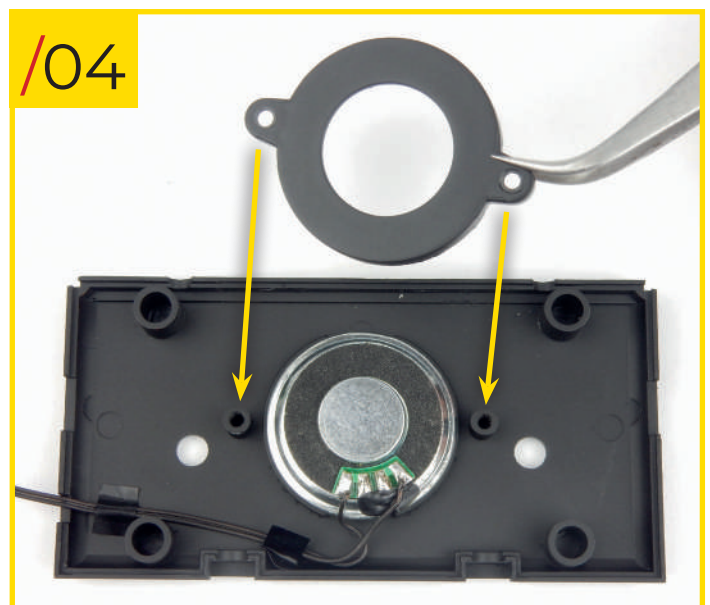

Stage 64: The First Set of Radiator Components

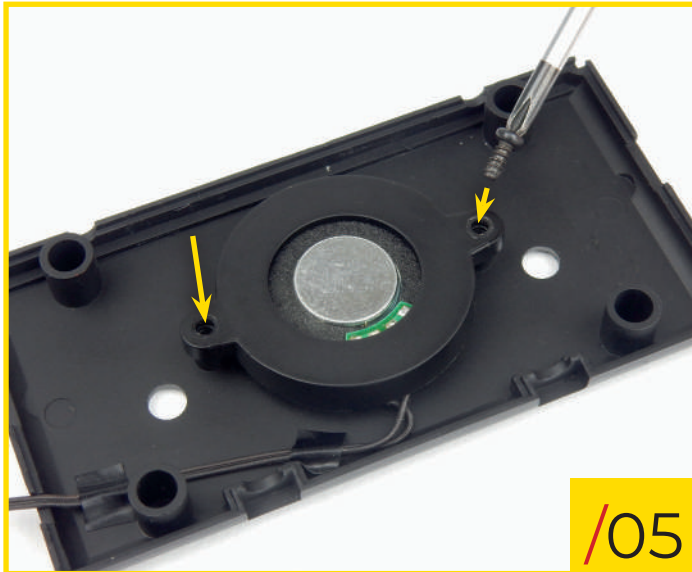

64/05 Screw two type B screws into the holes indicated to secure the locking ring into position.

64/06 Retrieve your model's chassis and fit the radiator back panel to it. Use the holes highlighted in the photo to help orientate the components correctly.

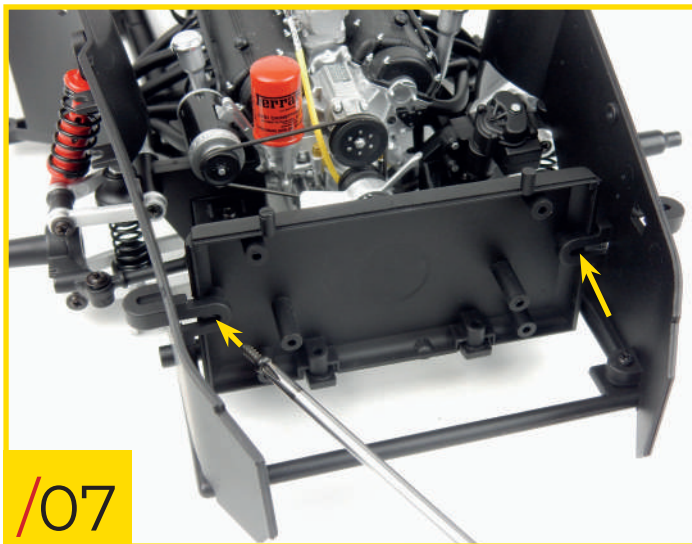
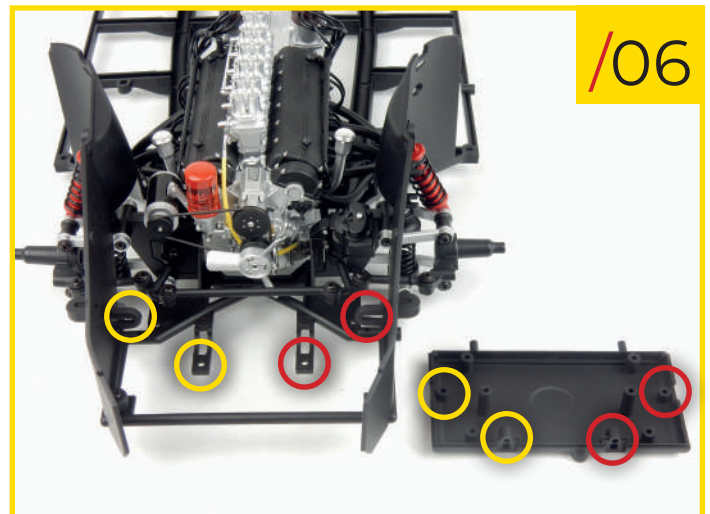

64/07 Screw two type B screws into the holes indicated to secure the panel to the chassis.

64/08 Turn the assembly over and, working on the underside of the chassis, screw another two type B screws into the holes indicated by the arrows in the photo.

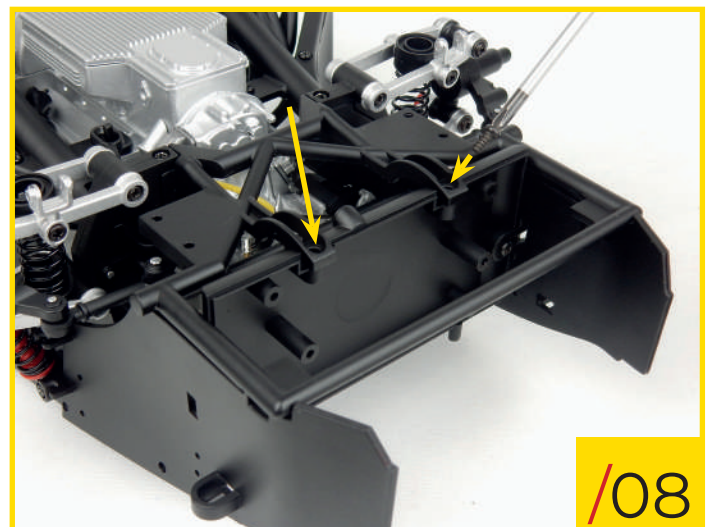

Stage 64: The First Set of Radiator Components

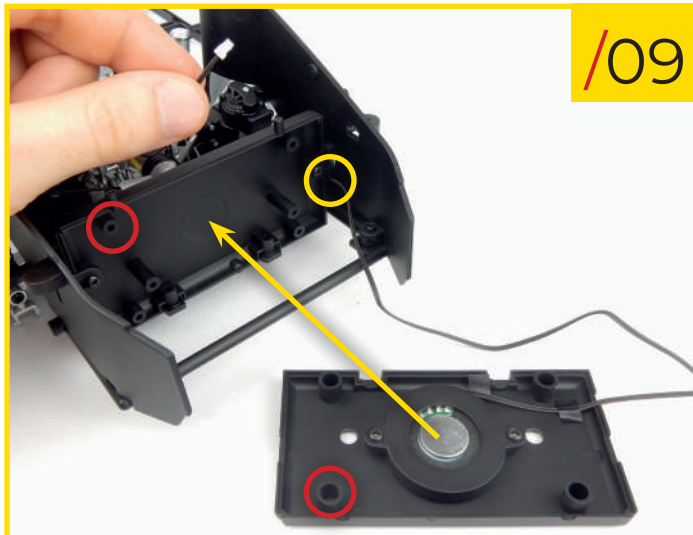

64/09 Thread the speaker cable through the opening indicated by the yellow circle in the photo. Press the speaker housing panel and back panel together, using the holes highlighted by the red circles in the photo to orientate the components correctly.

64/10 Fit the radiator cap to the radiator header by orientating the pieces as shown and inserting the stud on the cap into the hole in the header.



STAGE 64 IS COMPLETE
Here's how the first set of radiator components look once they've been correctly fitted. Keep the radiator header in a safe place, you'll need it for a later stage.

