

Ferrari

250 GTO



Pack 10

BUILD INSTRUCTIONS

STAGE 73: THE REAR LIGHTS

**STAGE 74: THE REAR NUMBER PLATE
AND BOOT LID**

STAGE 75: THE LEFT DOOR SUBFRAME

STAGE 76: THE RIGHT DOOR SUBFRAME

STAGE 77: THE FIREWALL DUCT

STAGE 78: THE FIREWALL FRAME

**STAGE 79: DASHBOARD AND
STEERING WHEEL COMPONENTS**

STAGE 80: FIREWALL COMPONENTS

Advice from the experts

To help you get the best out of building the Ferrari 250 GTO, we've prepared a modellers checklist with hints, tips and advice from our experts. The information below is aimed at making your build as enjoyable and professional as possible right from the start.

Have a soft cloth ready to place on your work surface to prevent scratching the paintwork.

Spare screws are included with each part. Occasionally, you may be instructed to keep spare or unused screws for a later stage. Keep these spares in a safe place and label them correctly.

Please make sure you don't mix up the screws. They look quite similar, but the threads do vary slightly. Using the wrong screws may damage the parts.

When securing parts together using multiple screws, fit each screw loosely to ensure all the parts are correctly aligned before gently tightening them firmly, but not overtight, in the order in which you placed them.

The screwdriver can be magnetized by stroking it with a magnet (fridge magnet, etc.) enabling it to hold the screws and make assembly easier.

If a screw is tight going into a metal part, do not force it as you may shear the head off. Remove it and put a tiny smear of Vaseline, soap or light oil on the thread. That will lubricate it and make it easier to drive home.

Only use the correct size screwdriver that fits the screw head firmly.

Use a magnet to help find screws that have fallen on the floor.

Use masking tape to hold parts temporarily in place.

Cut parts from a sprue (framework) with side cutters or a craft knife. Side cutters tend to be easiest.

During the course of this build, you will receive many pieces that you will assemble immediately – following the instructions in the corresponding stage – and other pieces that you should store safely to one side, for use in future assembly stages.

Left and Right! When building your *Ferrari 250 GTO*, the left- or right-hand side refers to that side as if you are sitting in the car.



WARNING: Some parts are assembled using magnets. These magnets can cause serious injury if they are swallowed. Keep away from children. If you suspect a magnet has been swallowed, seek medical help straight away.

All parts belong to a kit. Collectors item for adults.

Not suitable for children under 14.

Produced under license of Ferrari S.p.A. The name FERRARI, the PRANCING HORSE device, all associated logos and distinctive designs are property of FERRARI S.p.A. The body designs of the Ferrari cars are protected as Ferrari S.p.A. property under design, trademark and trade dress regulations.

Troubleshooting: The Steering Shaft

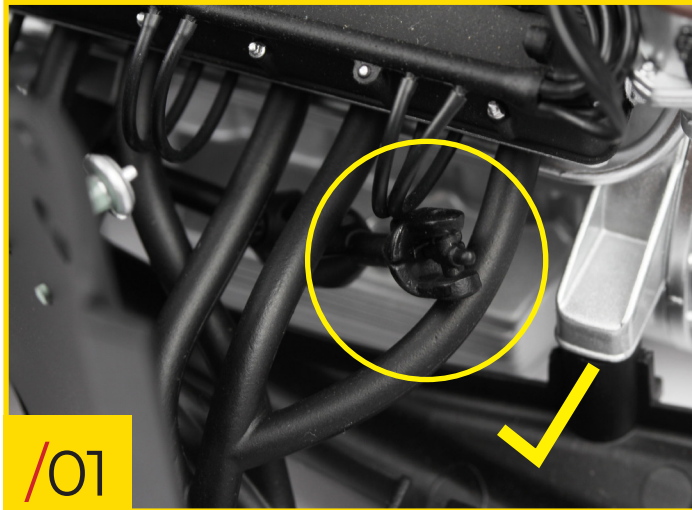

/01 Before starting Stage 73, check the steering shaft on your model is positioned correctly. The end should be between the rear left exhaust manifold pipes as shown in the image.

If it is not positioned correctly, follow steps 2 - 5.

/02 Push the rear left exhaust manifold down to release the pin (circled) from the chassis.

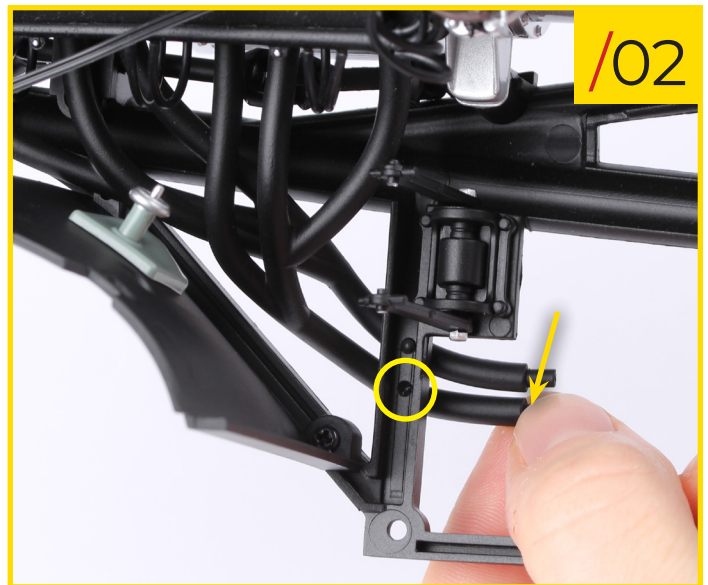

/03 Pull the three pins (circled) out from the engine.

Troubleshooting: The Steering Shaft

/04 Pull the steering shaft up between the exhaust manifolds pipes as shown.

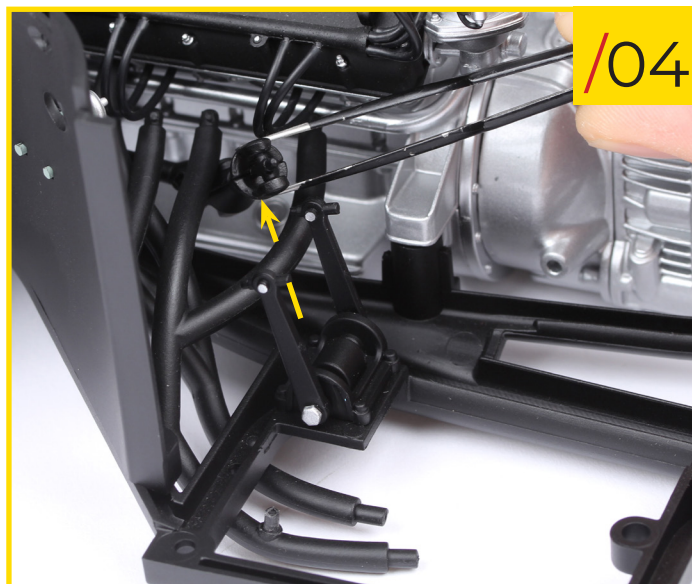

/05 Push the rear left exhaust manifold back into the engine and the chassis.

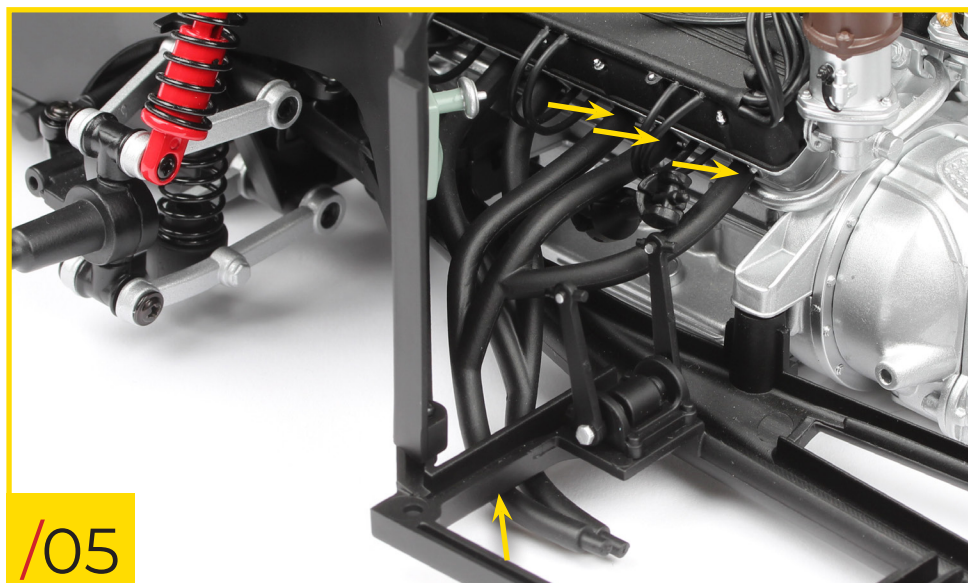

Stage 73: The Rear Lights

In this stage you'll fit the rear lights to the rear section of the body that you received with stage 68.



STAGE 73 PARTS LIST

Name
1 Indicators
2 Brake/parking lights
3 Reflector housings
4 Reflector lenses

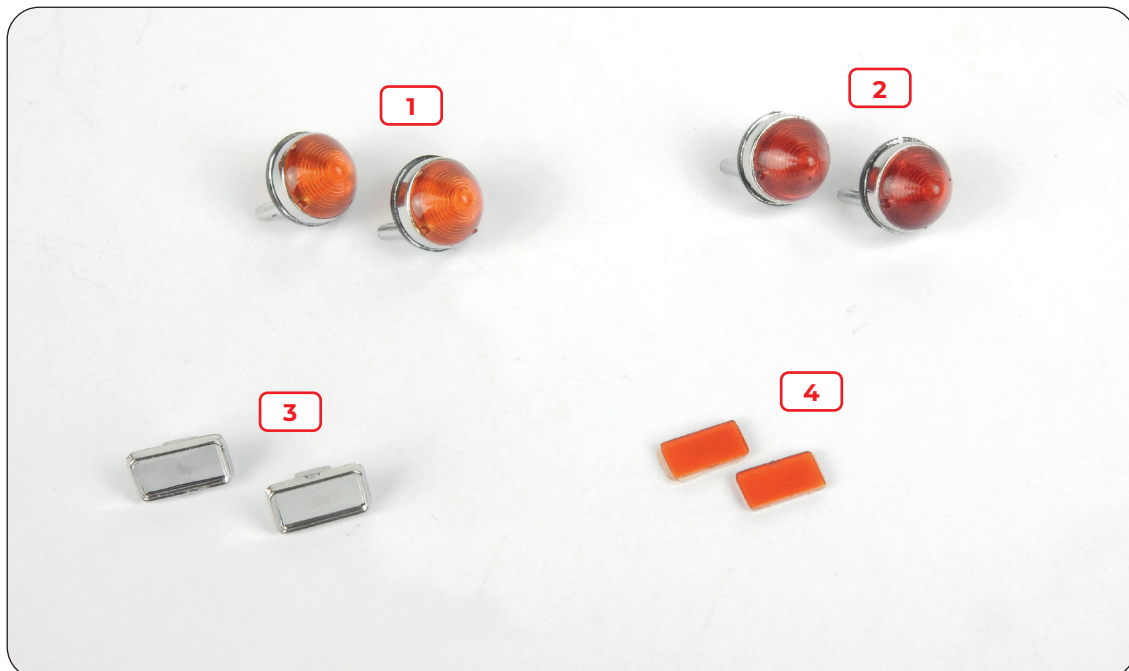

Stage 73: The Rear Lights



73/01 Place the rear section of the body (stage 68) on your work surface. Fit one of the indicators into its position on the left side of the body, orientating the parts as shown.

73/02 Push one of the brake/parking lights into position on the left side of the body, below the indicator.

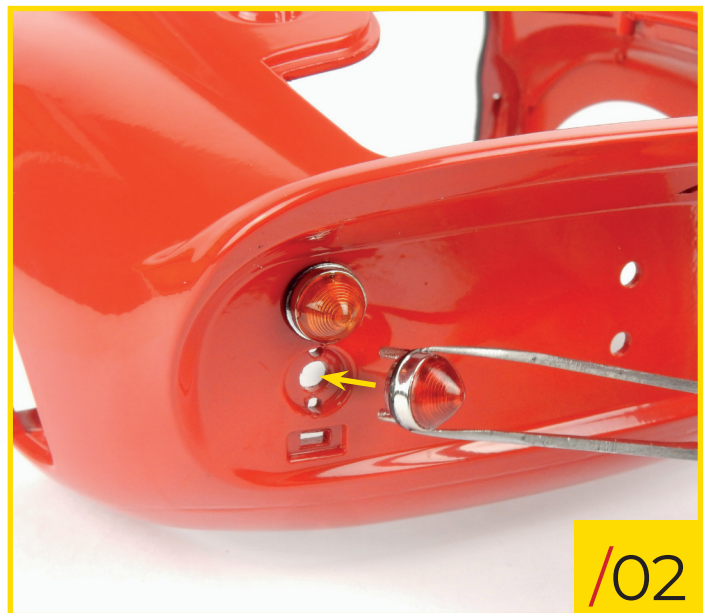

73/03 Fit the second indicator into position on the right side of the body.

Stage 73: The Rear Lights



73/04 Press the second brake/parking light into position on the right side of the body, below the indicator.

73/05 Remove the protective film from the backs of both the reflector lenses. Fit each of these to the reflector housings.

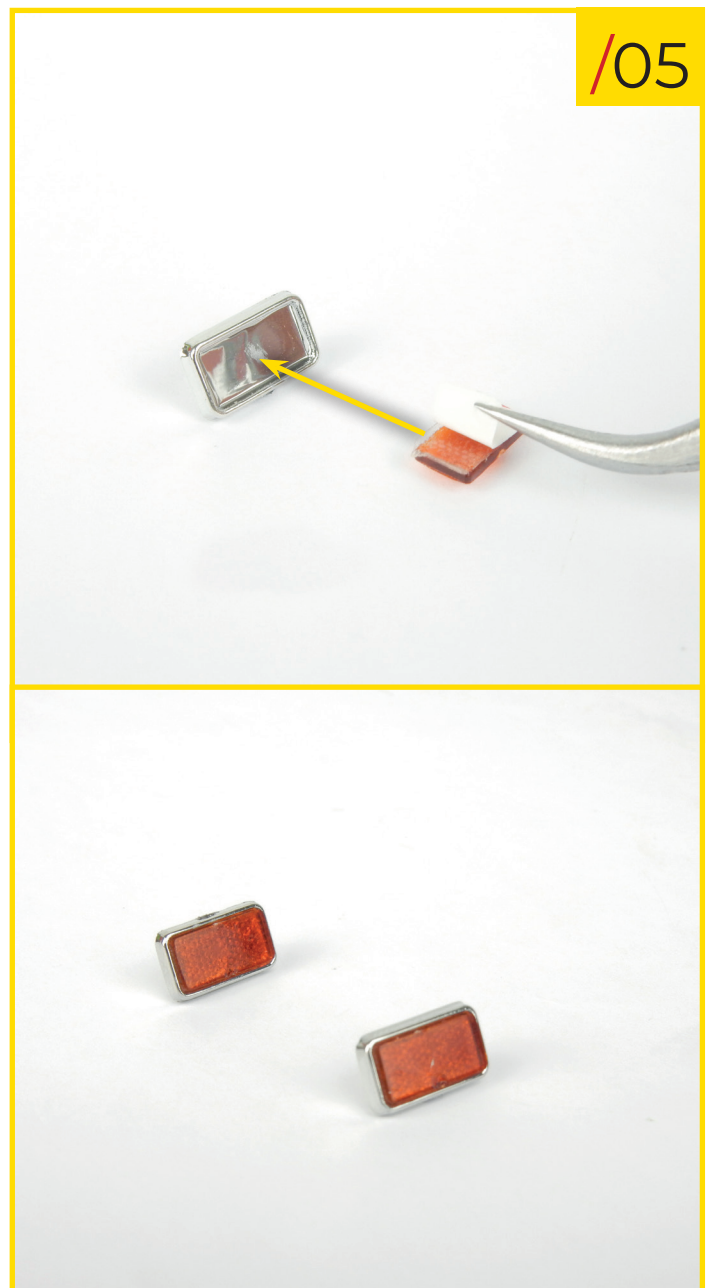

73/06 Place the first reflector into the rectangular hole on the left side of the body, below the indicator and brake/parking light.

Stage 73: The Rear Lights



/07

73/07 Finally, fit the second reflector to the right side of the body.



STAGE 73 IS COMPLETE
Here's how the rear section of the body looks with the rear lights fitted.

Stage 74: The Rear Number Plate and Boot Lid

In this stage you'll add the number plate, boot lid, and door locks to the rear section of your model's body.



STAGE 74 PARTS LIST

Name	Name
1 Boot lid	7 Right door lock
2 Boot lock	8 Number plate lights
3 Mounting plate	
4 Number plate housing	
5 Number plate	3 type C screws
6 Left door lock	2 type L screws



Stage 74: The Rear Number Plate and Boot Lid



74/01 Add the boot lock to the boot lid, orientating the pieces as shown. Before placing the lock into position, we recommend that you use a type L screw to enlarge the hole, this will make the next step easier to complete.

74/02 Working on the underside of the boot lid, secure the lock into position using a type L screw.

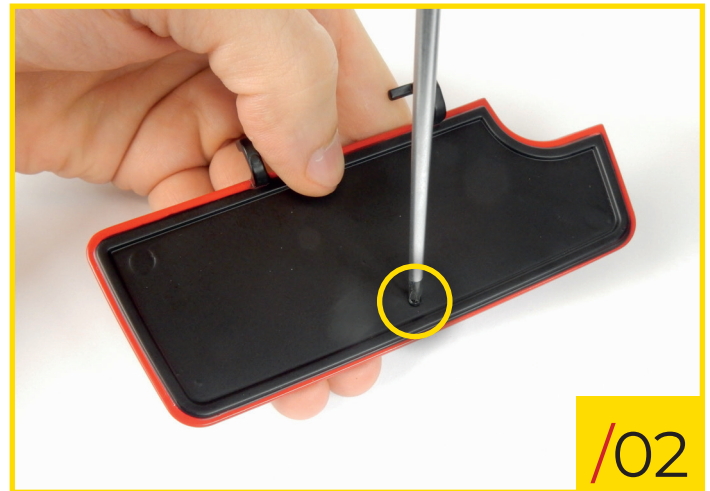

74/03 Retrieve the rear section of the body and fit the boot lid to it, orientating the pieces as shown.



74/04 Turn the assembly over and place the mounting plate onto the boot lid's hinges. Orientate the pieces as shown in the photo and screw two type C screws into the holes in the plate. Screw them tightly and check that the plate fits snugly against the body: when you lift the boot lid, the plate should remain securely in place.



Stage 74: The Rear Number Plate and Boot Lid



74/05 Put the left door lock into its hole in the rear section of the body. Orientate the pieces as shown: the hole in the lock should be facing outwards.

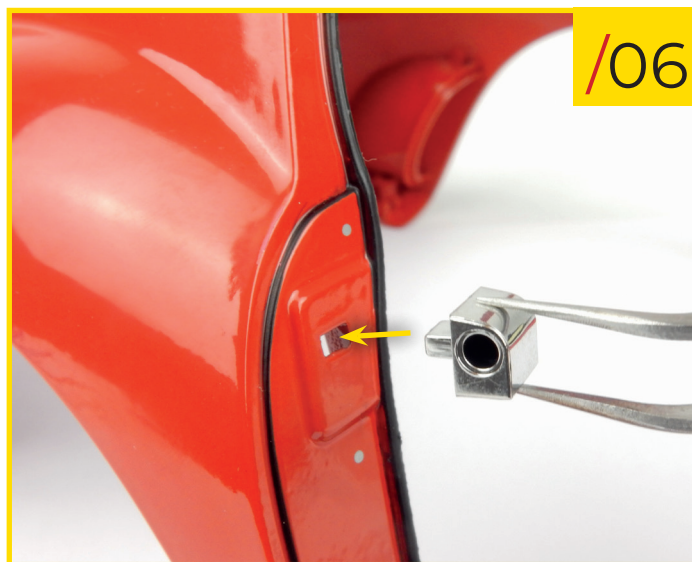

74/06 Similarly, fit the right door lock into its position.

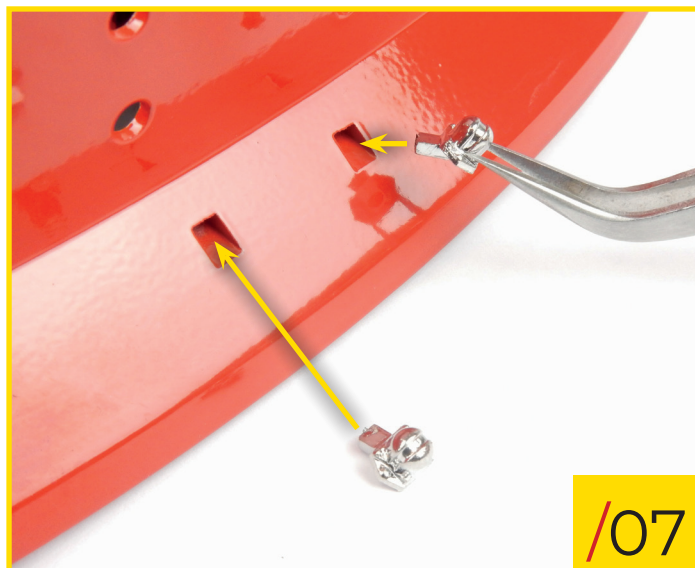

74/07 Insert the two number plate lights into the dedicated holes in the rear of the body. Orientate the pieces as shown.



74/08 Fit the number plate to its housing, use the photo and the shape of the pieces to ensure you orientate them correctly. Use glue if needed.

Stage 74: The Rear Number Plate and Boot Lid

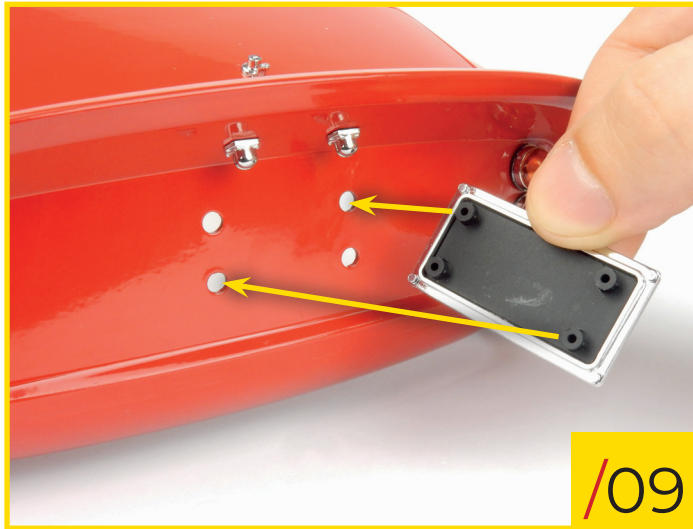

74/09 Fit the number plate assembly to the rear section of the body by inserting the studs into the dedicated holes. Do not use glue if you plan to finish your model using the N.A.R.T. decals.



STAGE 74 IS COMPLETE
Here's how the rear section of your model's body looks at the end of this assembly stage.

Stage 75: The Left Door Subframe

In this stage you'll assemble the subframe for the left door together with the boot frame.



STAGE 75 PARTS LIST

Name	Name	Name
1 Boot frame	5 Left door footboard	2 type B screws
2 Left door subframe	6 Plate	8 type C screws
3 Fuel filler pipe part 1	7 Roll-bar	3 type N screws
4 Fuel filler pipe part 2	8 Extinguisher	

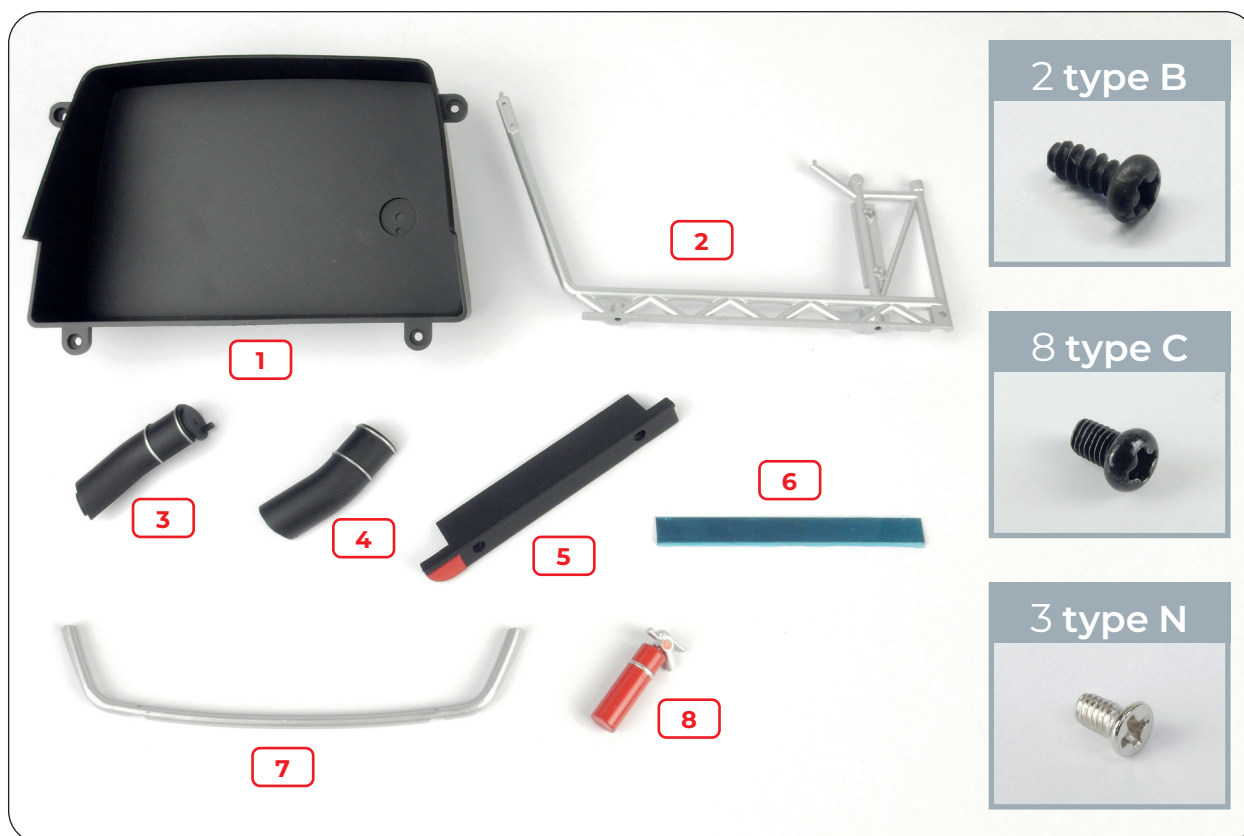

Stage 75: The Left Door Subframe



75/01 Fit the two fuel filler pipe parts together, orientating them as shown in the photo. There's only one way that the pieces can fit together.



75/02 Fit the pipe into its dedicated position on the inside of the boot frame. Similarly, there is only one way to fit them together.

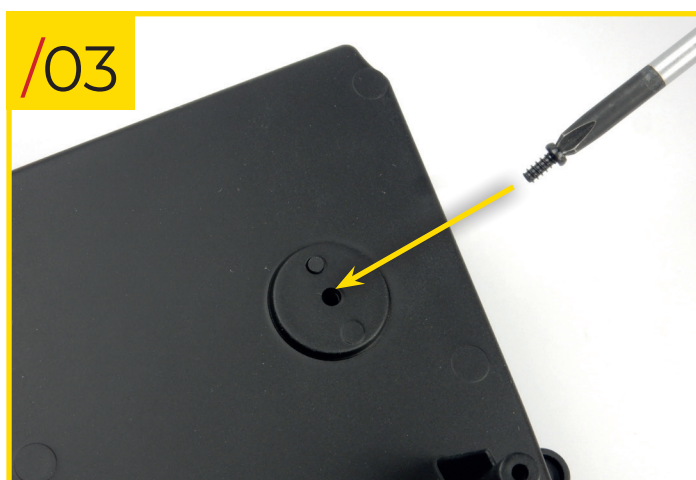

75/03 Turn the assembly over and secure the tube to the frame using a type B screw.

75/04 Retrieve the rear section of the body and remove the reinforcement bar. Unscrew the two screws holding it in position. There's no need to keep the bar and screws, they won't be required for any future assembly sessions.



Stage 75: The Left Door Subframe

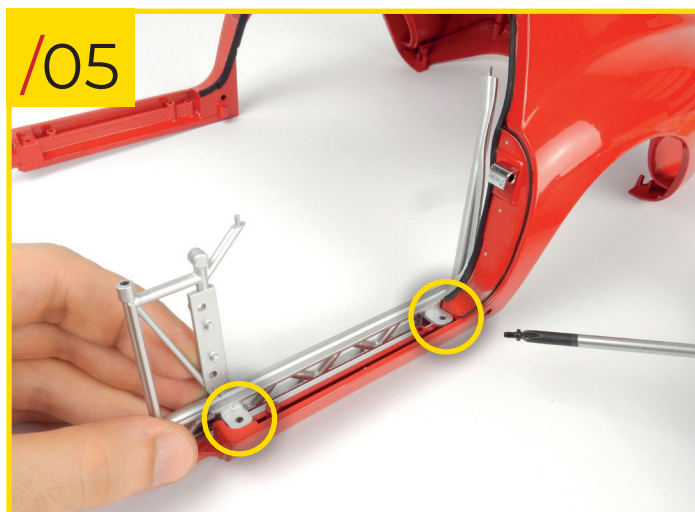

75/05 Fit the left door subframe into position, as shown in the photo. Secure it into position by screwing two type C screws into the holes indicated.

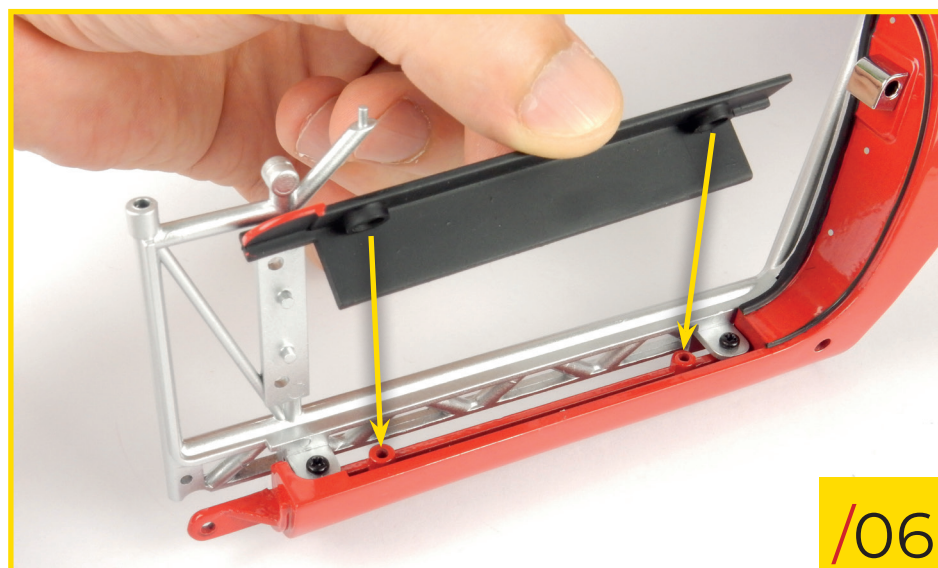

75/06 Fit the left door footboard, use the photo and the shape of the pieces to ensure you orientate them correctly.

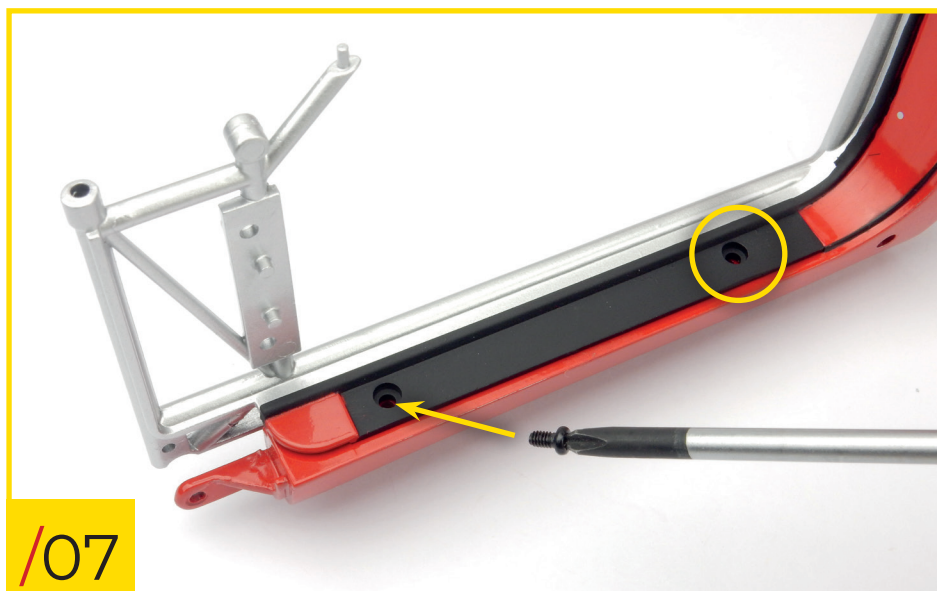

75/07 Screw two type C screws into the holes indicated to secure the footboard to the body.

Stage 75: The Left Door Subframe

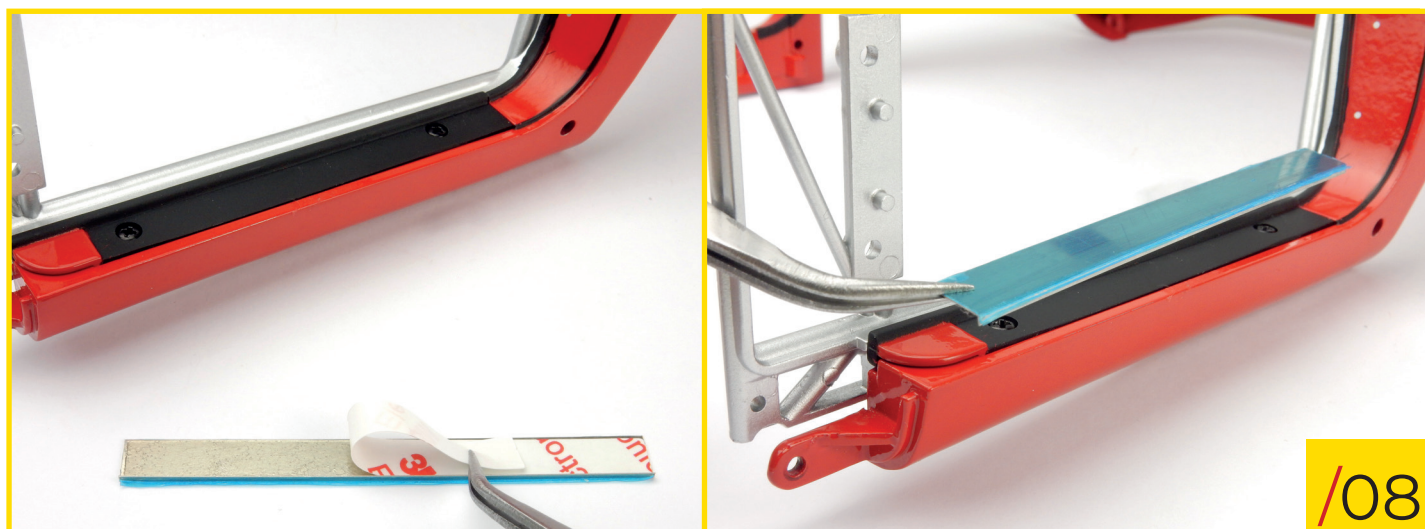

75/08 Remove the protective film from the back of the plate and place it onto the black part of the footboard to hide the screws. Orientate the pieces as shown and, for the time being, don't remove the blue film: the surface of the plate will remain protected during future assembly sessions.

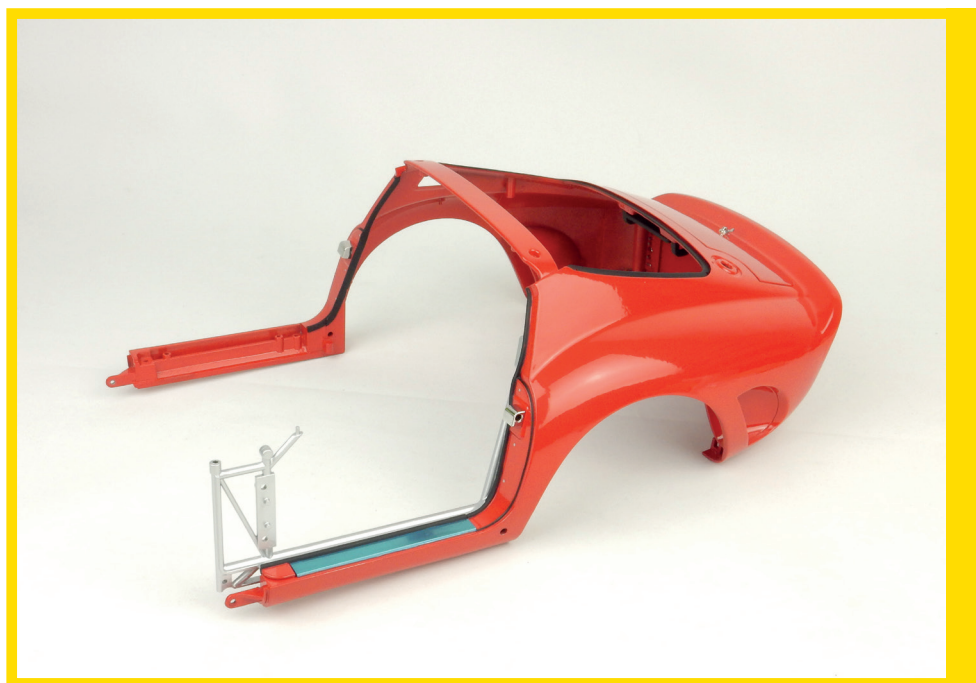

STAGE 75 IS COMPLETE
Here's how your model's body looks at the end of this assembly session. Keep the components that you haven't used during this session somewhere safe.

Stage 76: The Right Door Subframe

In this stage you'll fit the subframe for the right door to the rear section of the body.



STAGE 76 PARTS LIST

Name	Name
1 Right door subframe	8 type C screws
2 Right door footboard	
3 Plate	

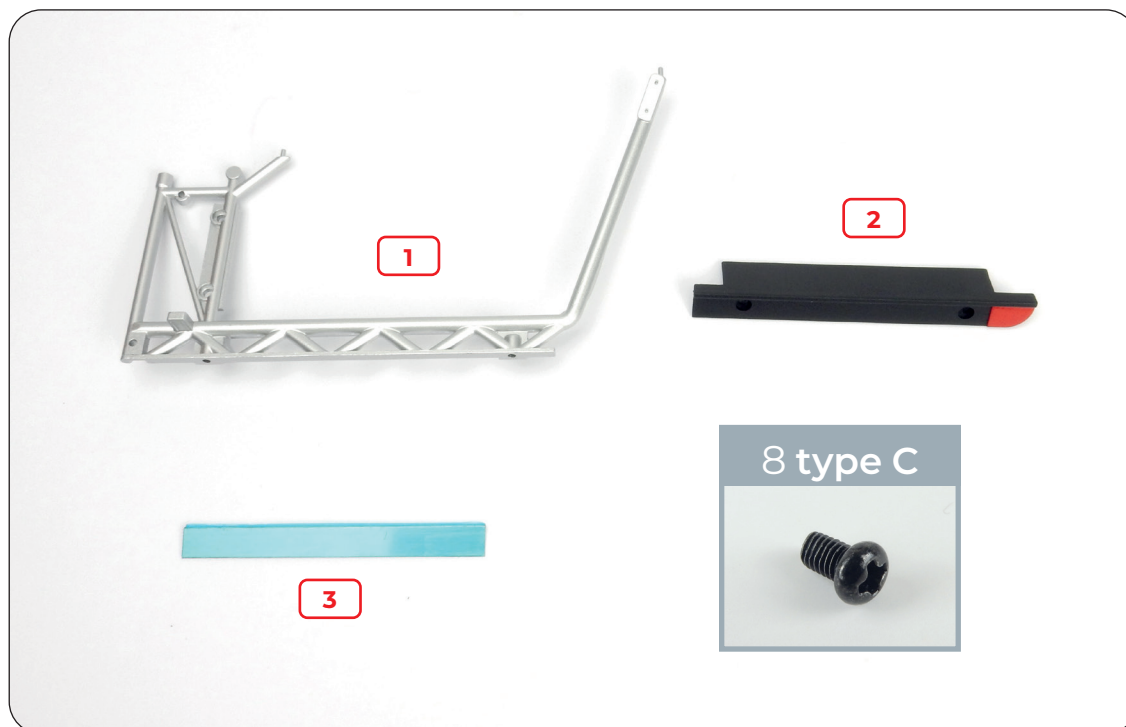

Stage 76: The Right Door Subframe

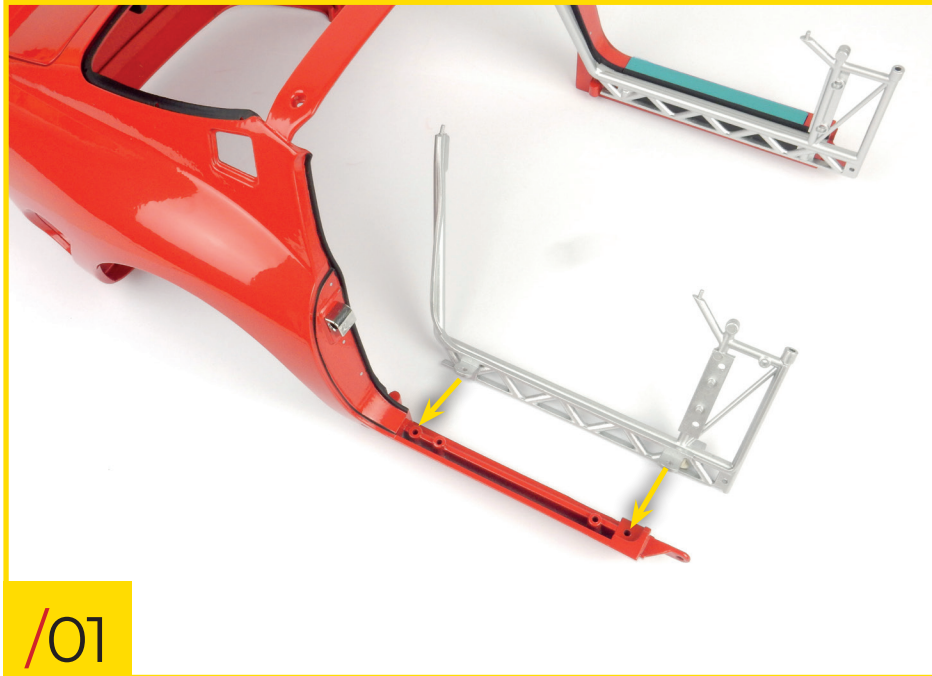

76/01 Retrieve the rear section of your model's body and fit the right door subframe into position, orientating the pieces as shown.

76/02 Secure the subframe into position by screwing two type C screws into the holes indicated.

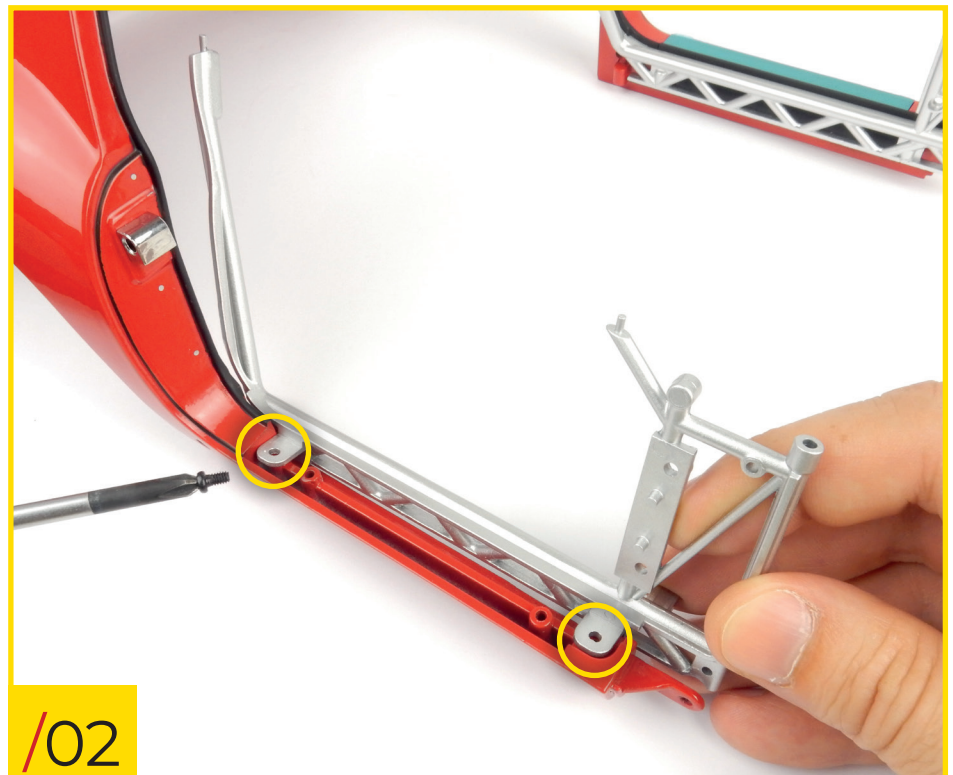

Stage 76: The Right Door Subframe

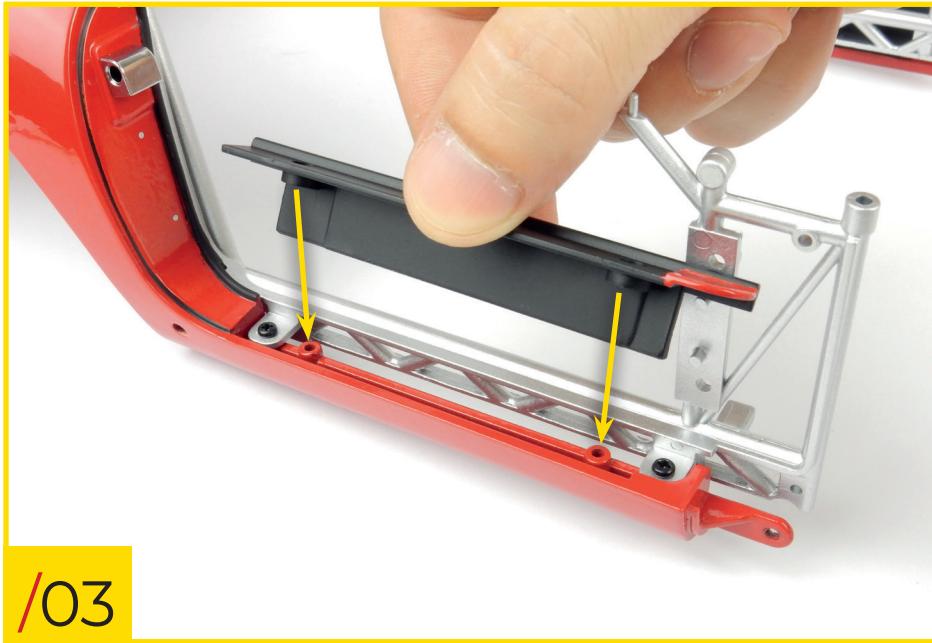

76/03 Fit the right door footboard to the body, use the photo and the shape of the pieces to ensure you orientate them correctly.



76/04 Screw two type C screws into the holes indicated to secure the footboard to the body.

Stage 76: The Right Door Subframe



76/05 Remove the protective film from the back of the plate and place it in the orientation shown onto the black part of the footboard to hide the screws. Don't remove the blue film yet, it will protect the surface of the plate during future assembly sessions.

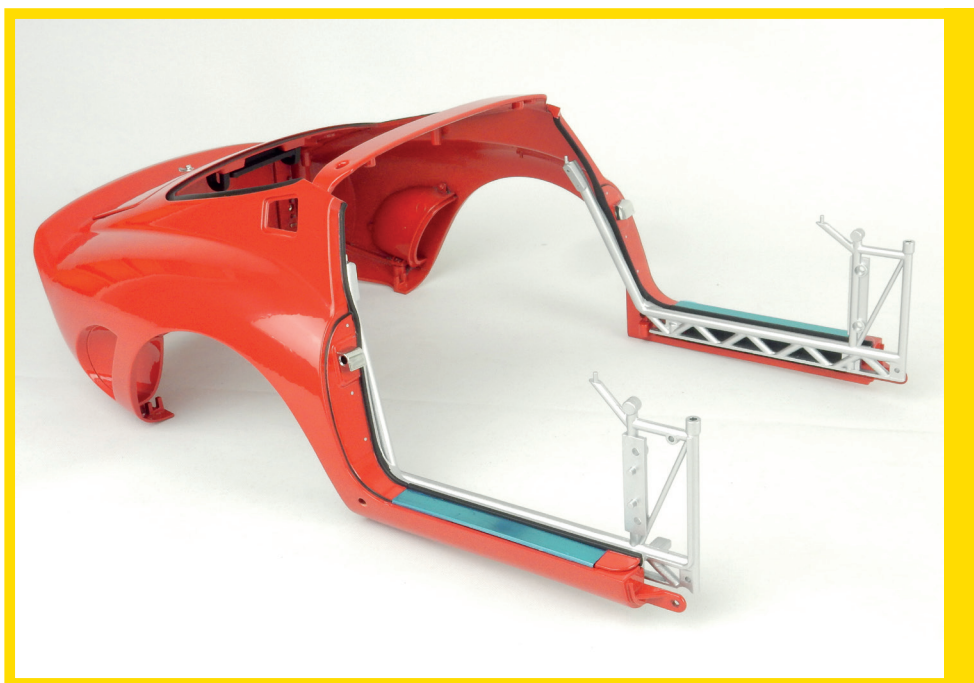

STAGE 76 IS COMPLETE
Here's how your model's body looks once the right door subframe has been fitted.

Stage 77: The Firewall Duct

In this stage you'll start assembling the components for your model's firewall.



STAGE 77 PARTS LIST

Name	Name
1 Firewall	3 type M screws
2 Duct part 1	
3 Duct part 2	
4 Side plates	

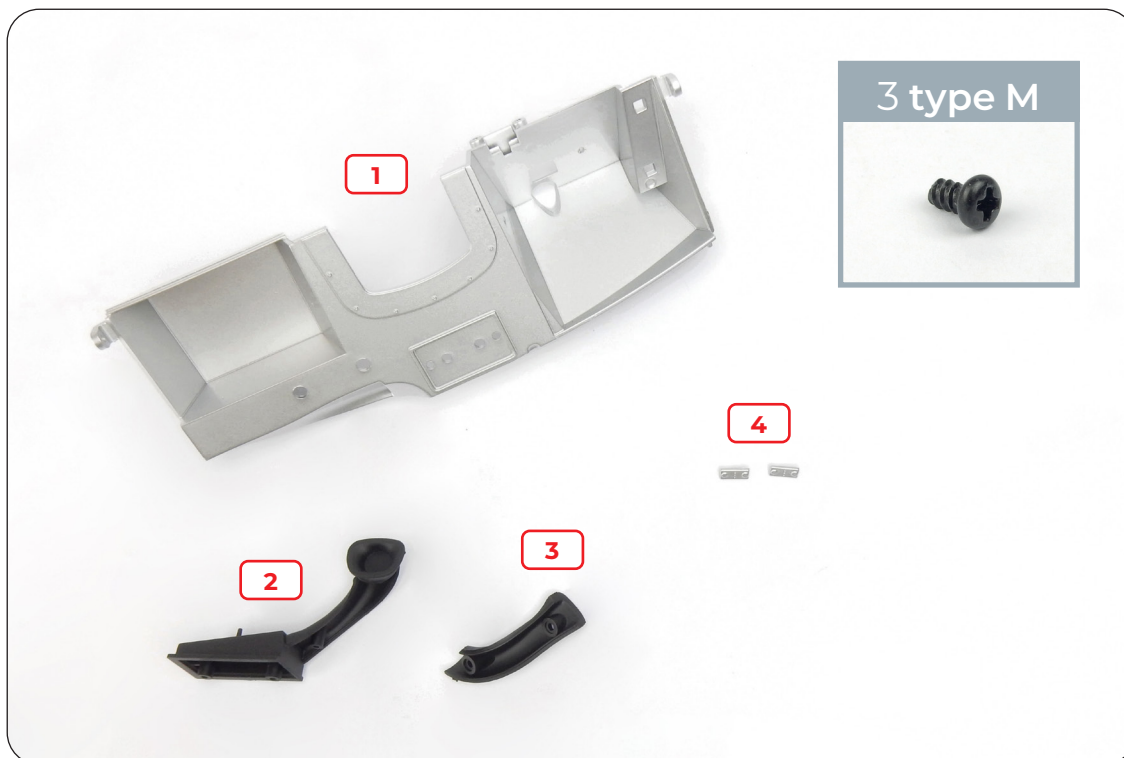

Stage 77: The Firewall Duct



77/01 Fit the two parts of the duct together. Use the photo and the shape of the pieces to ensure you orientate them correctly.

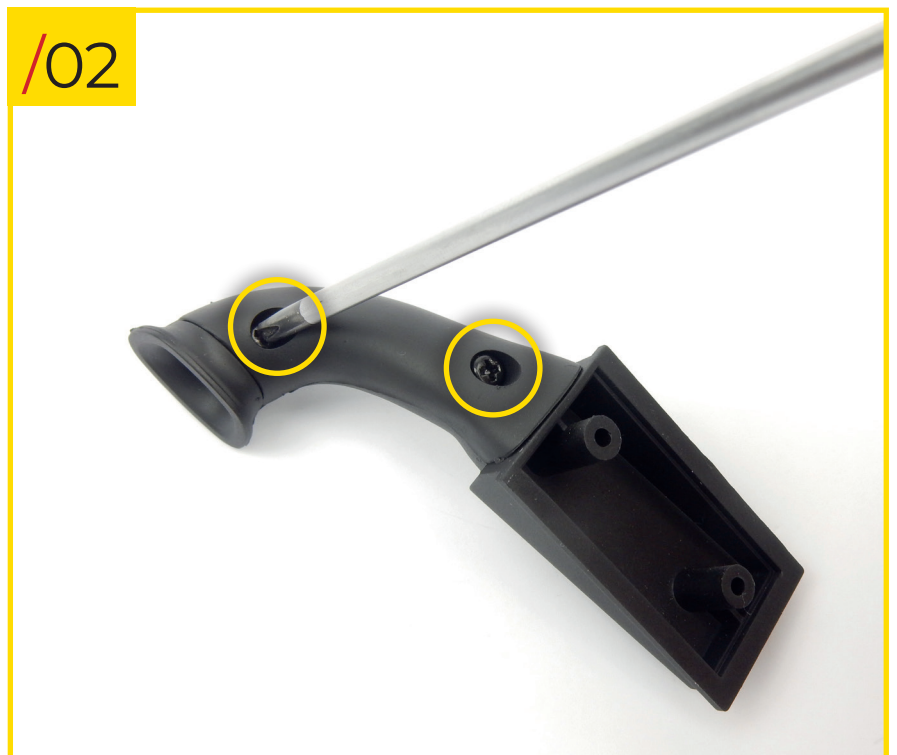

77/02 Secure the pieces together using two type M screws.

Stage 77: The Firewall Duct



STAGE 77 IS COMPLETE
Here's how the firewall duct looks at the end of this stage. Keep it somewhere safe together with the firewall and the two side plates.

Stage 78: The Firewall Frame

In this stage you'll continue assembling your model's firewall.



STAGE 78 PARTS LIST

Name	Name
1 Firewall frame	7 type M screws
2 Footrest	
3 Dashboard support	

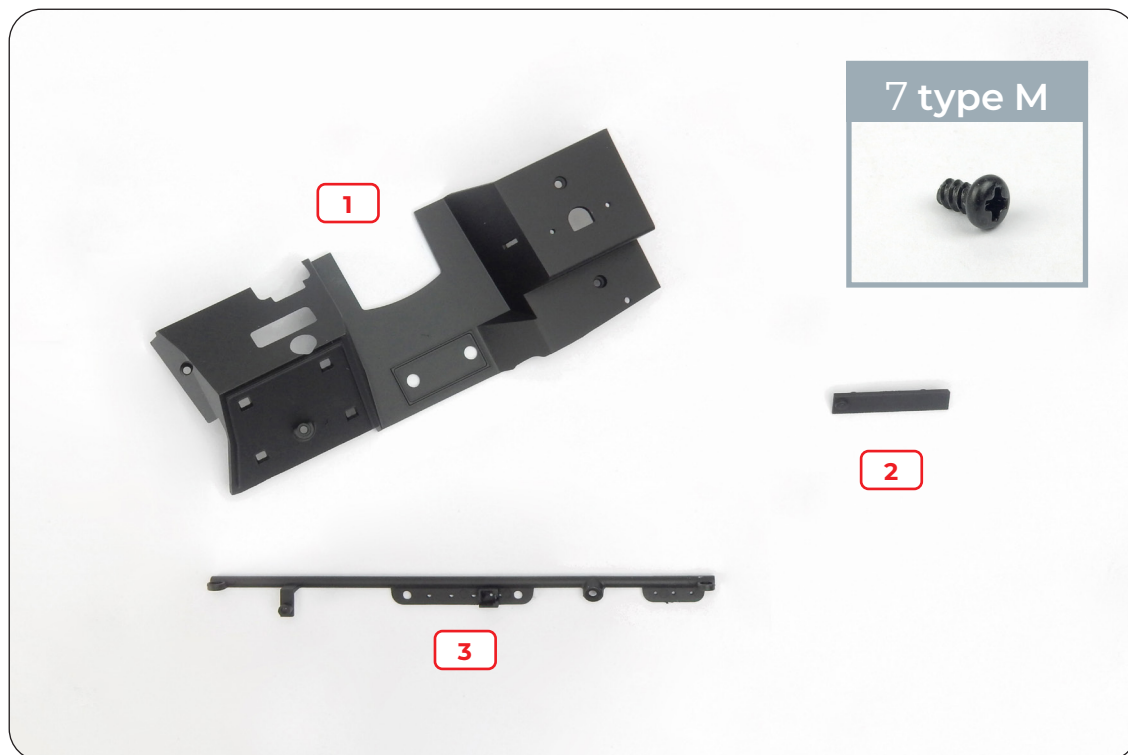

Stage 78: The Firewall Frame

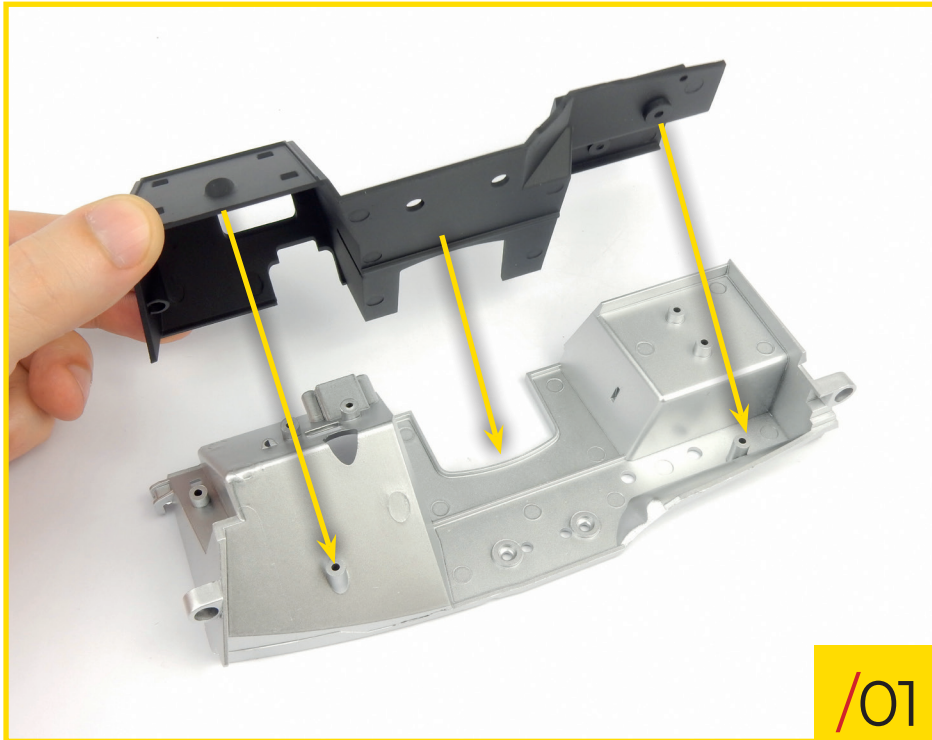

78/01 Retrieve the firewall you received with stage 77 and fit the firewall frame to it. Orientate the pieces as shown in the photo.

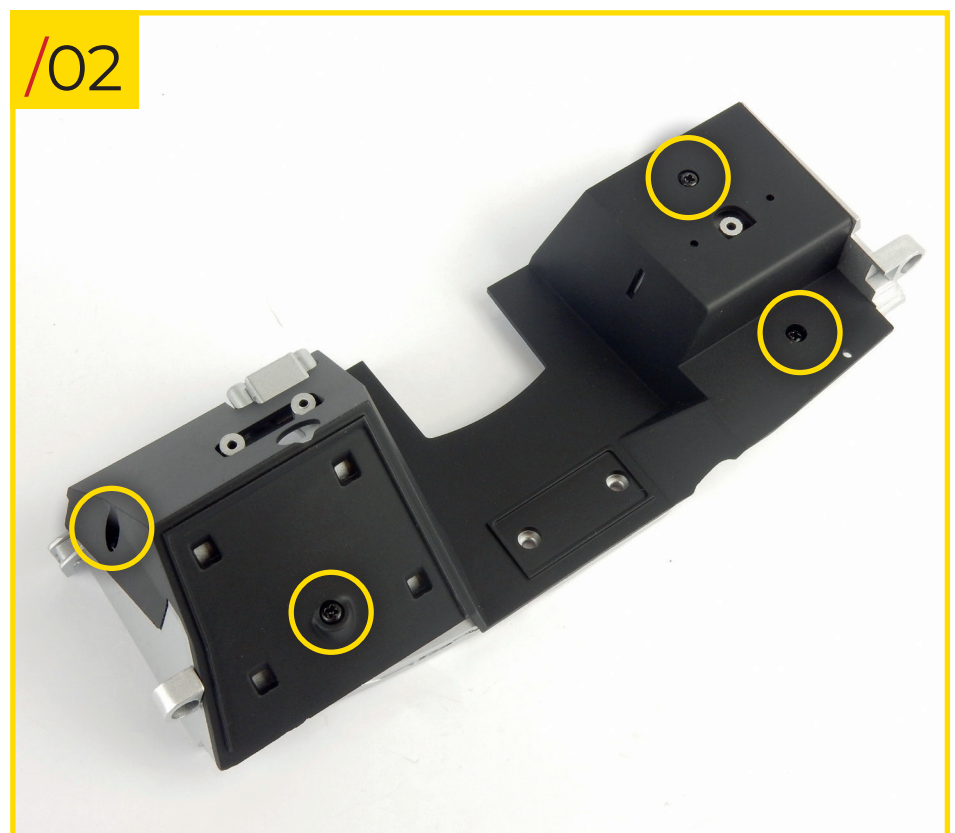

78/02 Secure the pieces together by screwing four type M screws into the holes indicated in the photo.

Stage 78: The Firewall Frame

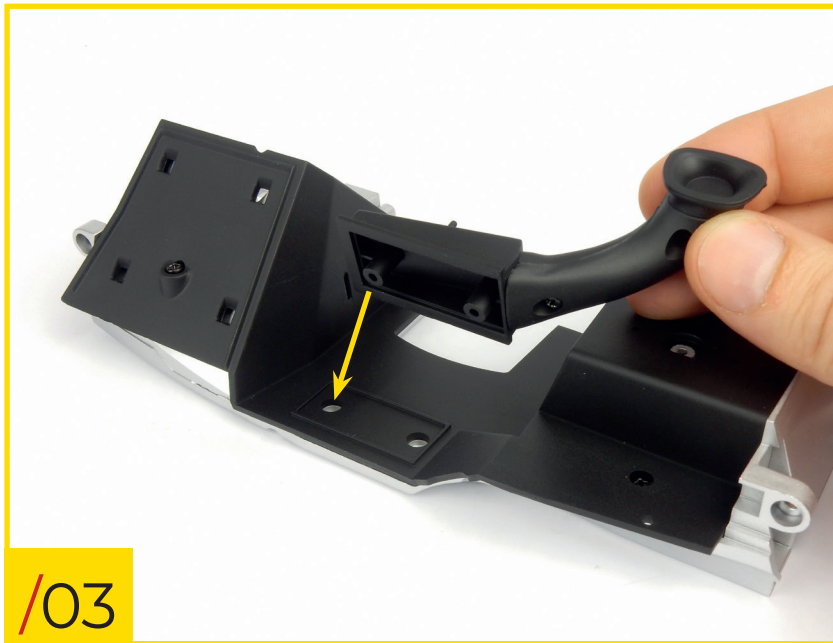

78/03 Retrieve the duct you assembled in stage 77 and fit it to the firewall assembly, as shown in the photo.

78/04 Secure the duct to the firewall by screwing two type M screws into the holes indicated.

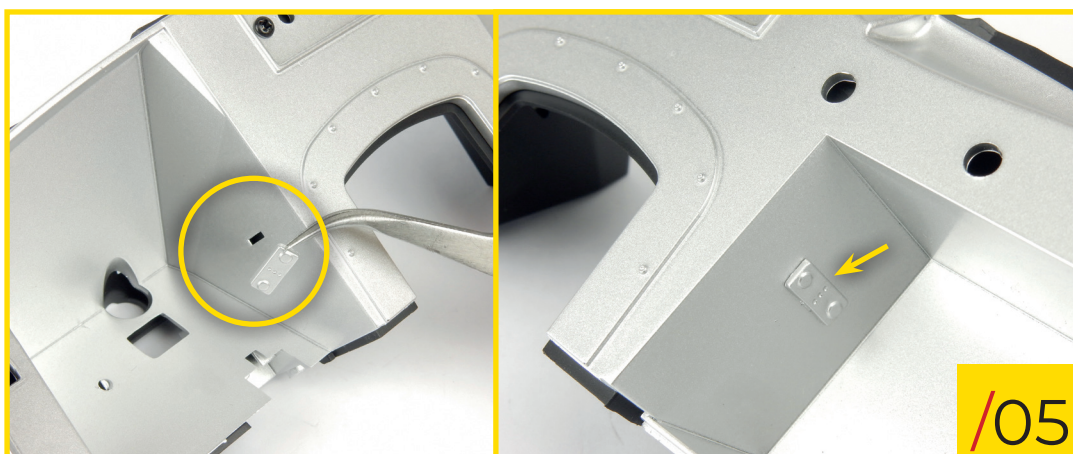
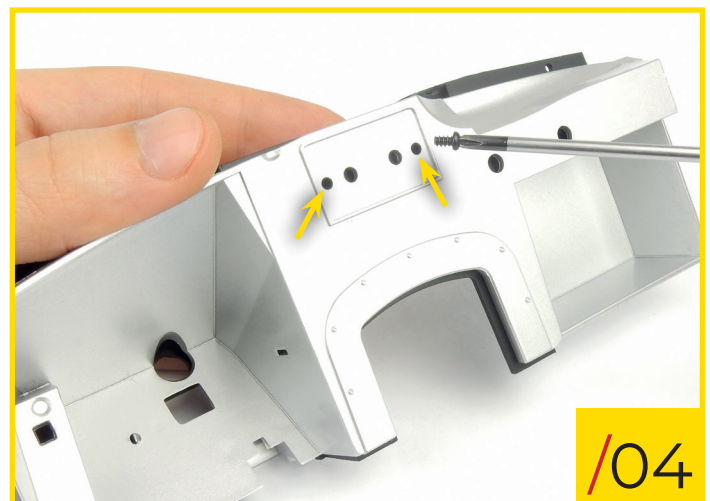

78/05 Also retrieve the two side plates you received with stage 77 and fit them into position on the firewall.

Stage 78: The Firewall Frame

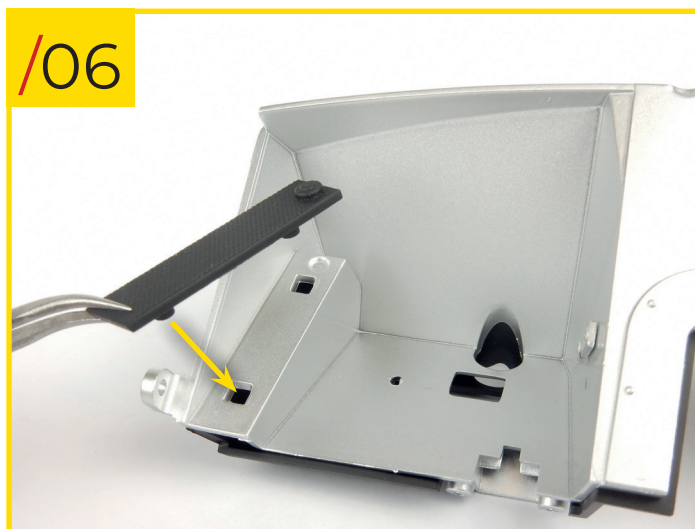

78/06 Finally, fit the footrest into its dedicated position on the left of the firewall.



STAGE 78 IS COMPLETE
Here's how your model's
firewall looks at the end of
this stage.

Stage 79: Dashboard and Steering Wheel Components

In this stage you'll assemble various components belonging to the dashboard and steering wheel.



STAGE 79 PARTS LIST

Name	Name
1 Switch lever base	6 Rear view mirror
2 Washer	7 Instrument lights
3 Switch lever	8 Cable with switch
4 Steering base A	
5 Steering base B	3 type L screws

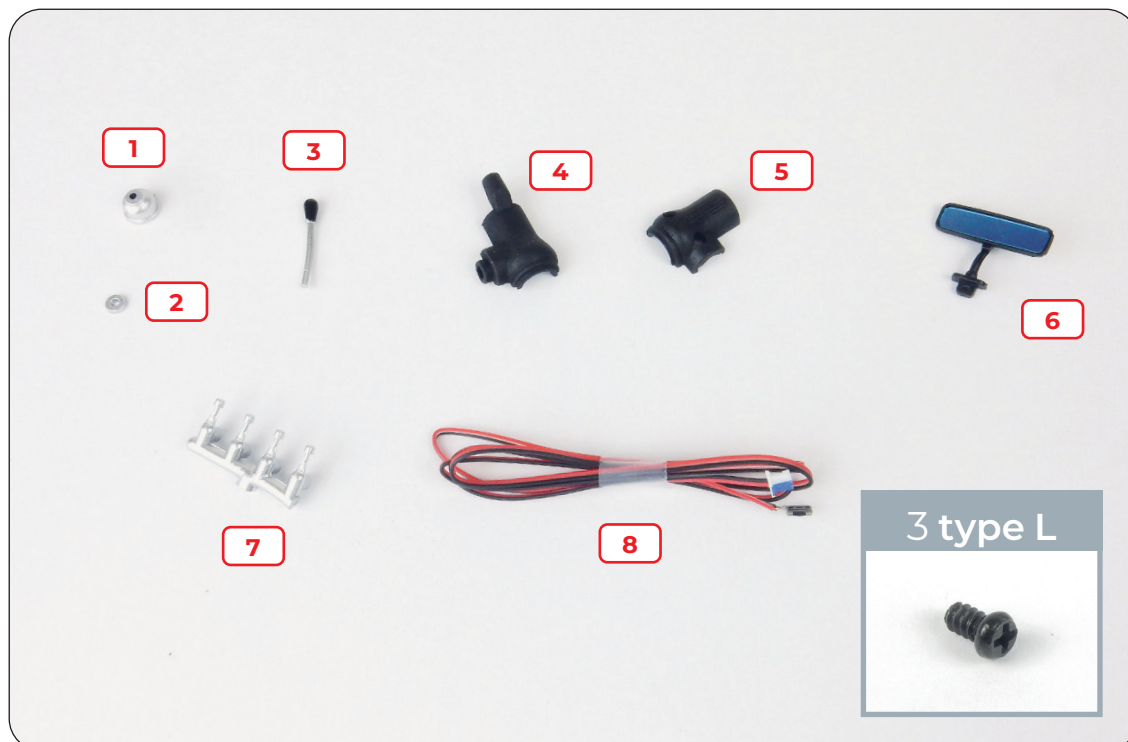

Stage 79: Dashboard and Steering Wheel Components



79/01 Using a suitable cutting tool, detach the four instrument lights from their sprue. Be careful not to damage the pieces.



79/02 Retrieve your model's dashboard that you worked on in stages 2 and 3, and fit the pieces into the holes indicated in the photo. If you feel it's necessary, you can put a drop of glue on the studs before pushing them into the holes.

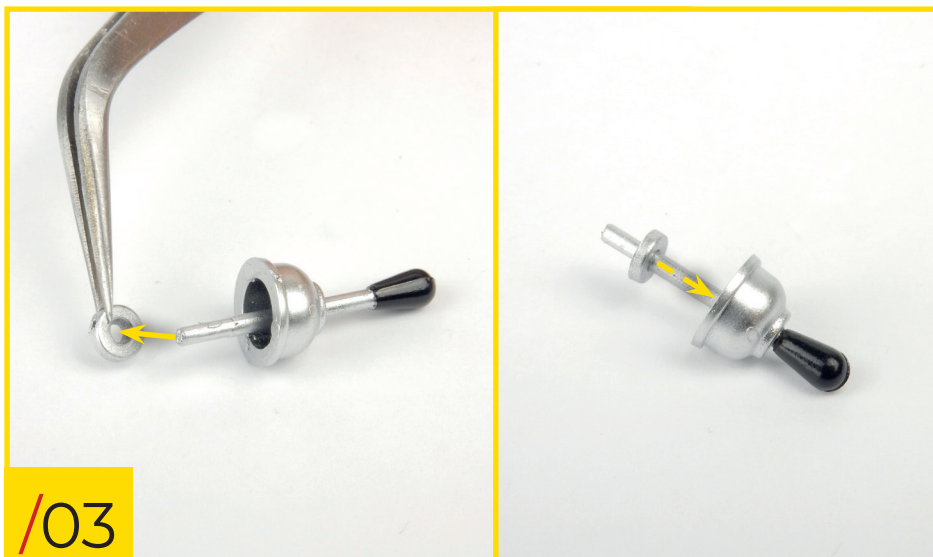

79/03 Push the switch lever into its base and then through the hole in the washer. Orientate the pieces as shown in the photo and push the washer until it can go no further.

Stage 79: Dashboard and Steering Wheel Components

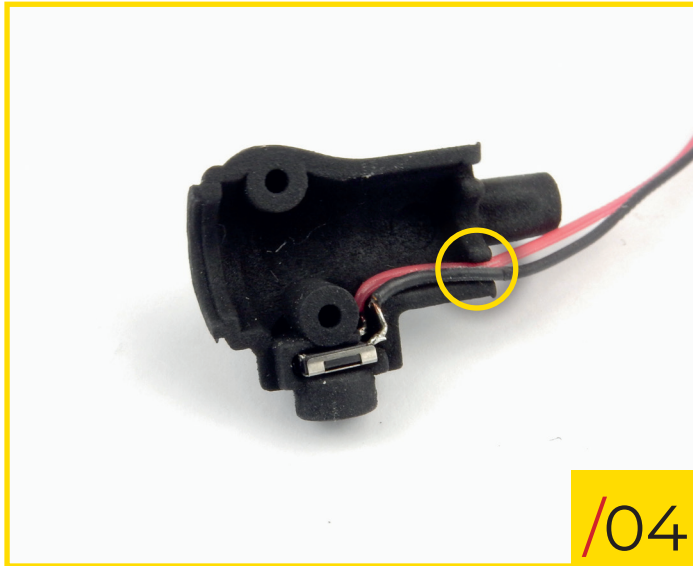

79/04 Place the switch that's attached to the cable into the dedicated position on the inside of steering base A and position the cable as shown. Be careful not to damage the pieces whilst carrying out this step.

79/05 Fit the switch lever assembly to steering base A, orientating the pieces as shown. Apply some light pressure to the switch lever until you hear the "click" of the switch, this tells you that it's working properly.



79/06 Retrieve the steering wheel assembly that you assembled in stage 1, and fit steering base A to it. Orientate the pieces as shown and be careful not to damage any of the components, particularly the cables. Make sure both cables are threaded through the notch.

Stage 79: Dashboard and Steering Wheel Components

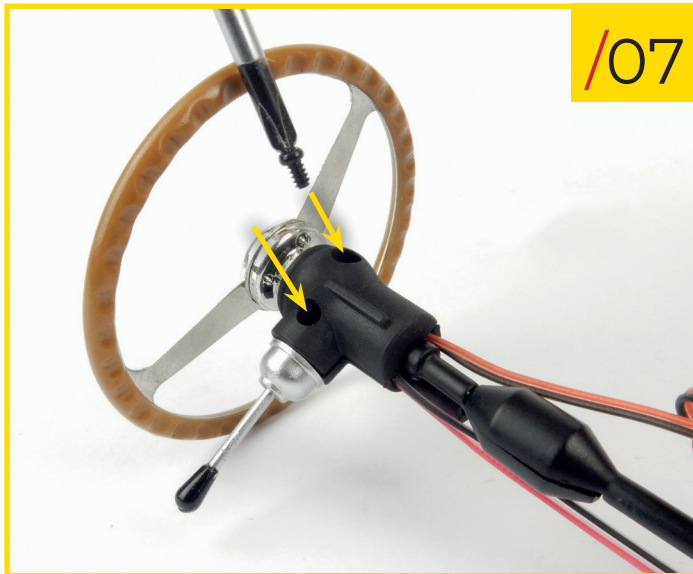

79/07 Fit steering base B to the rest of the assembly. Secure the pieces together using two type L screws.



STAGE 79 IS COMPLETE
Here's how your model's dashboard and steering column look at the end of this assembly phase. Keep them in a safe place together with the rear view mirror.

Stage 80: Firewall Components

In this stage you'll add several smaller components to your model's firewall.



STAGE 80 PARTS LIST

Name	Name
1 Small component 1	7 Pipe housing
2 Small component 2	8 Passenger compartment air pipes
3 Small component 3	9 A switch
4 Small component 4	10 B switches
5 Fuse boxes	11 C switches
6 Electrical system baseboard	

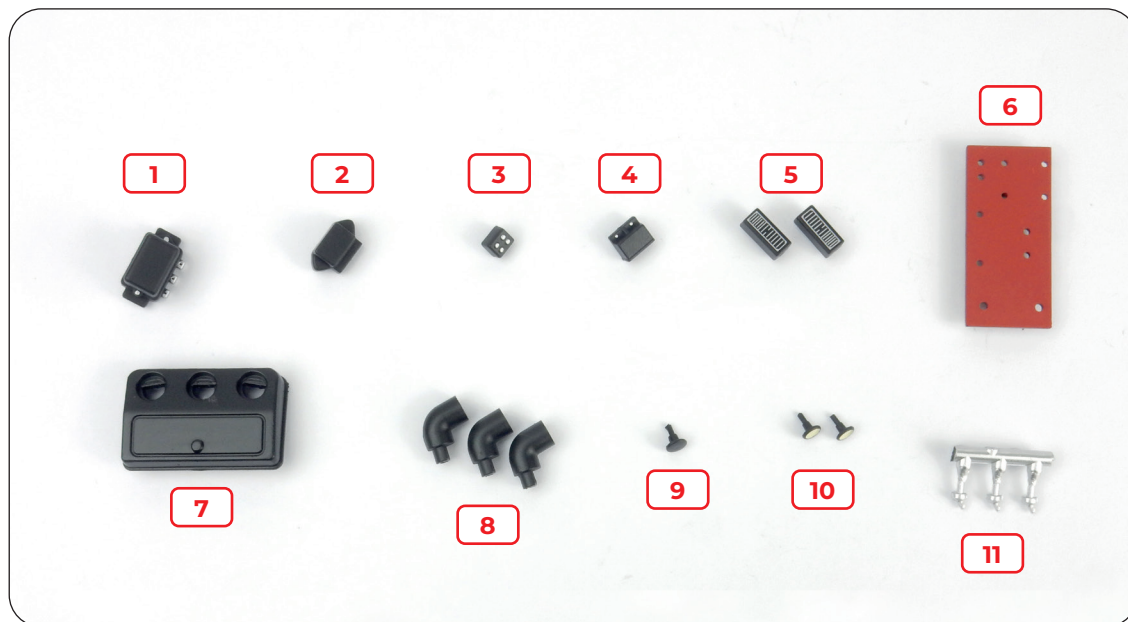

Stage 80: Firewall Components

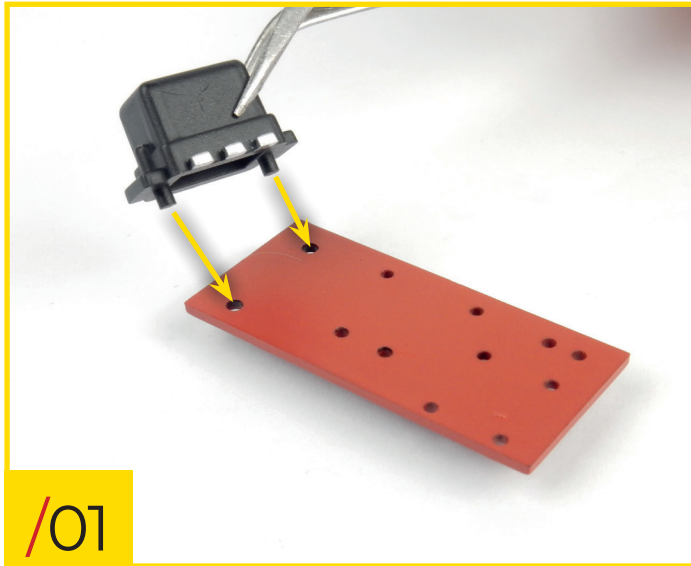

80/01 Place the electrical system baseboard on your work surface, orientating it exactly as shown in the photo. Fit the small component 1 to it, into the position indicated. Some light pressure will need to be applied.

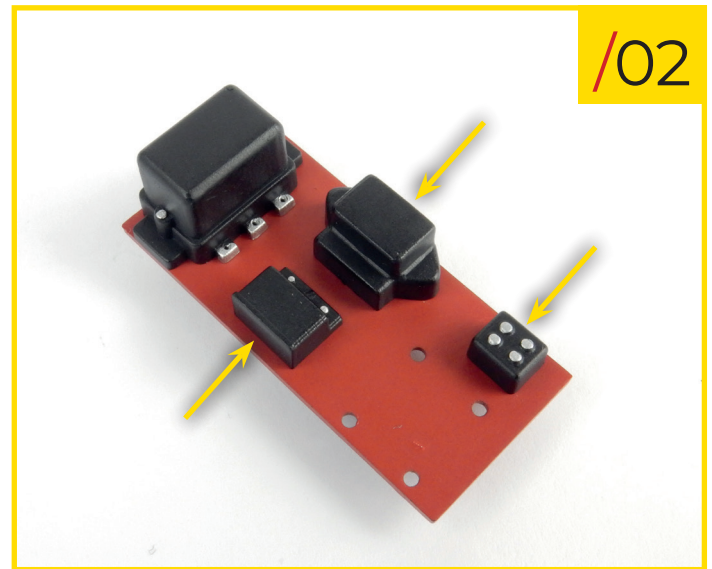

80/02 Fit the small components 2, 3 and 4 to the electrical system baseboard, into the positions indicated in the photo.

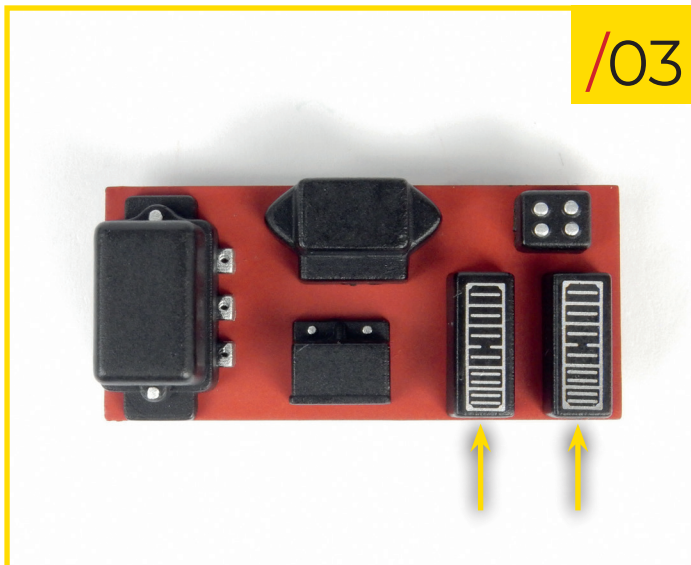

80/03 Also fit the two fuse boxes to the baseboard. Some light pressure will also need to be applied in this case. Look at the photo carefully to ensure the pieces are oriented correctly.

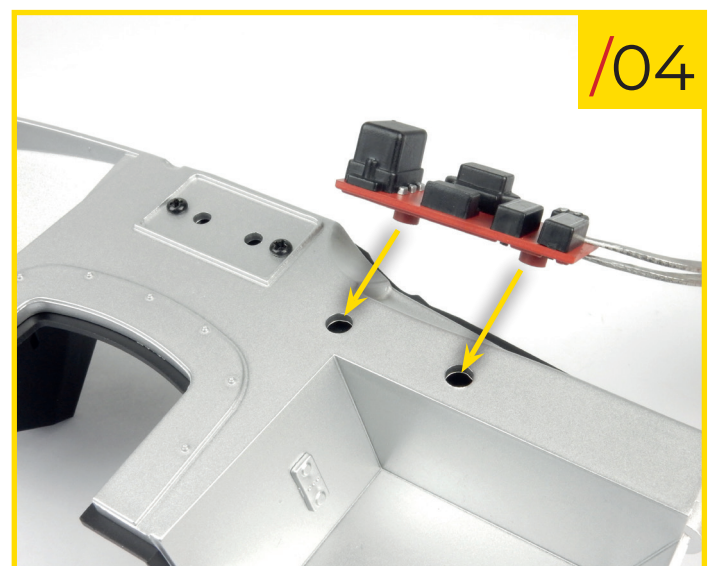

80/04 Retrieve your model's firewall that you worked on in stages 77 and 78, and fit the electrical system baseboard assembly to it, into the position indicated in the photo.

Stage 80: Firewall Components



80/05 Fit the pipe housing to the firewall, into the position shown in the photo. Insert the studs on the housing into the dedicated holes in the firewall.



80/06 Insert the semi-circular ends of the three air pipes into the semi-circular holes in the housing. There's only one way that the pieces can fit together.



80/07 Retrieve the dashboard support you received with stage 78. Insert the A switch and B switches into the holes indicated in the photo (A switch into the central hole, B switches into the outer holes).

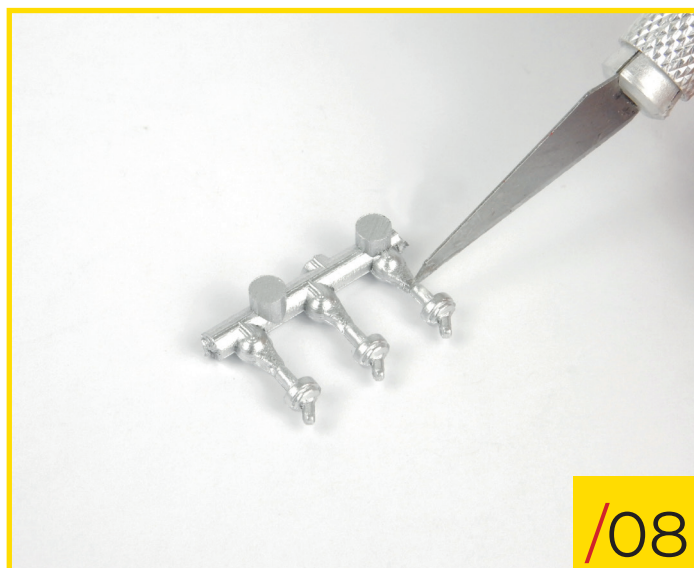

80/08 Using a suitable cutting tool, detach the three C switches from their sprue. Be careful not to damage the pieces.

Stage 80: Firewall Components



80/09 Insert the semi-circular ends of the three C switches into the dedicated semi-circular holes in the central section of the dashboard support. There's only one way that the pieces can be secured together.

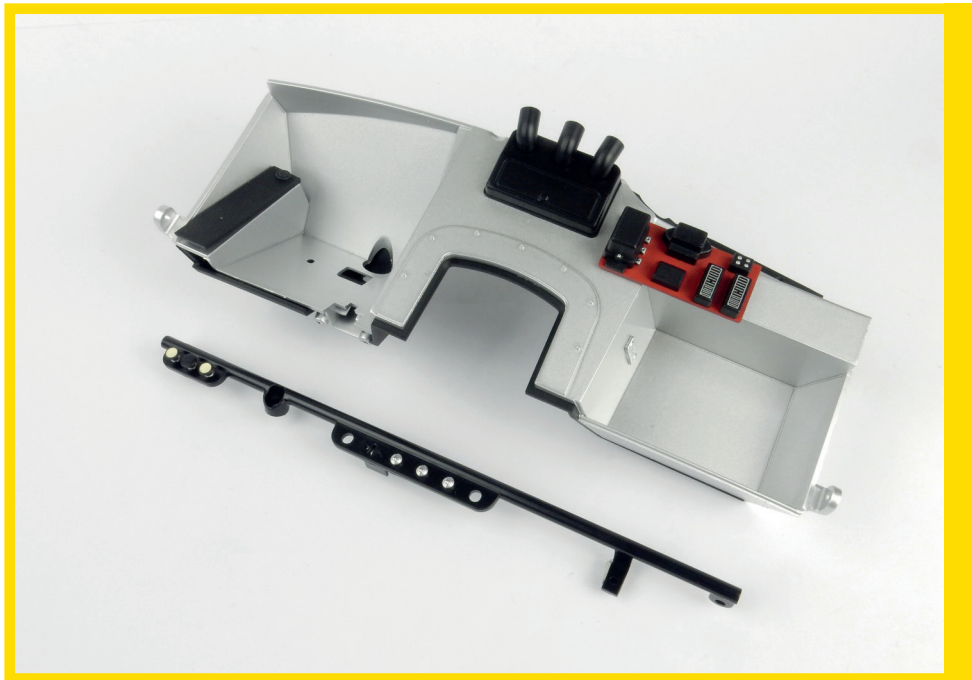

STAGE 80 IS COMPLETE
Here's how the firewall and the dashboard support look at the end of this stage.