

MITSUBISHI A6M ZERO FIGHTER



Pack 02 | Build Instructions

Your 1:18 model of the Japanese Zero is reproduced in the most exquisite detail, with electronics allowing you to recreate aeronautical operations such as take-off and landing, turning, firing and night combat. Lights, machine-gun and propeller sounds bring your legendary fighter plane to life.

In your second model pack, you will assemble:

STAGE 06: BUILDING THE ENGINE

STAGE 07: BUILDING THE ENGINE

STAGE 08: BUILDING THE ENGINE

STAGE 09: BUILDING THE ENGINE

STAGE 10: BUILDING THE ENGINE

STAGE 11: BUILDING THE ENGINE

STAGE 12: BUILDING THE ENGINE

STAGE 13: BUILDING THE ENGINE

STAGE 14: BUILDING THE ENGINE

STAGE 15: BUILDING THE ENGINE



There are excellent videos showing how to build the Zero [here](#).

Advice from the experts

Spare screws are included with each part. Occasionally, you may be instructed to keep spare or unused screws for a later stage.

Keep these spares in a safe place and label them correctly.

Please make sure you don't mix up the screws. They look quite similar, but the threads do vary slightly. Using the wrong screws may damage the parts.

When securing parts together using multiple screws, fit each screw loosely to ensure all the parts are correctly aligned before gently tightening them firmly, but not overtight, in the order in which you placed them.

The screwdriver can be magnetised by stroking it with a magnet (fridge magnet, etc.) enabling it to hold the screws and make assembly easier.

If a screw is tight going into a metal part, do not force it as you may shear the head off. Remove it and put a tiny smear of Vaseline, soap or light oil on the thread. That will lubricate it and make it easier to drive home.

During the course of this build, you will receive many pieces that you will assemble immediately – following the instructions in the corresponding stage – and other pieces that you should store safely to one side, for use in future assembly stages.

When gluing parts together, glue may be applied to either of the two parts. Some experts find it easier to apply glue to a hole rather than a pin. Choose a method that works best for you.

It's a good idea to test fit your parts so that you can check their positioning before gluing.

Not suitable for children under the age of 14. This product is not a toy and is not designed for use in play. Keep the parts out of the reach of small children. Some parts may have sharp edges. Please handle them with care.

Stage 06: Building the Engine

Stage 06 Assembly

The Engine



STAGE 06 PARTS

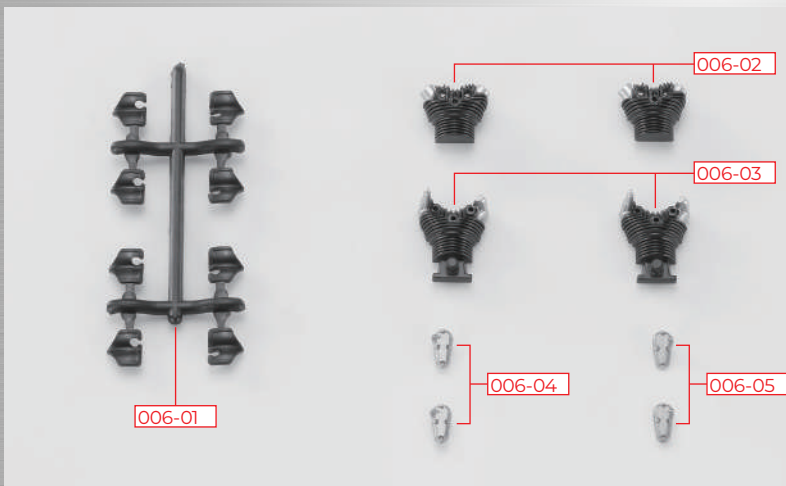

You will also need: superglue, tweezers.

PARTS LIST

	Part	No.	Material
<input type="checkbox"/>	006-01	8 (1 spare)	ABS resin
<input type="checkbox"/>	006-02	2	Die-cast
<input type="checkbox"/>	006-03	2	Die-cast
<input type="checkbox"/>	006-04	2	ABS resin
<input type="checkbox"/>	006-05	2	ABS resin

STEP 1

← : Glue
 - - - : Don't Glue

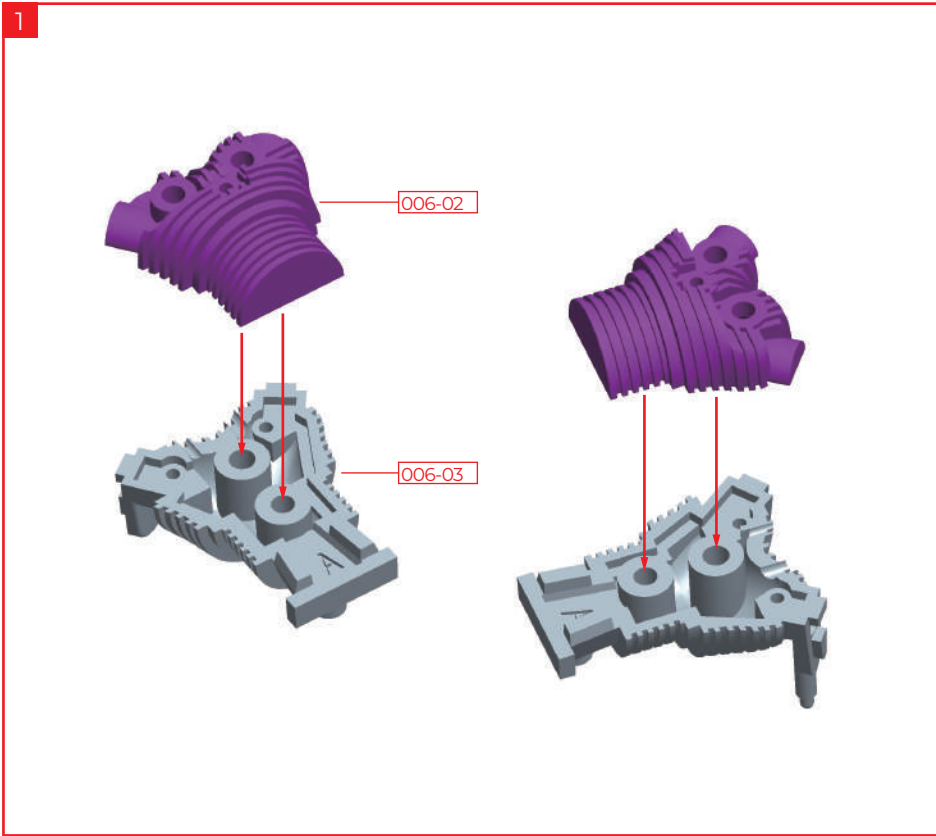

Apply a small amount of superglue to the two pins of 006-02 and insert them into the holes of 006-03. Make two of these.

NOTE
 Cylinders 006-02 & 006-03 are marked with the letter A.

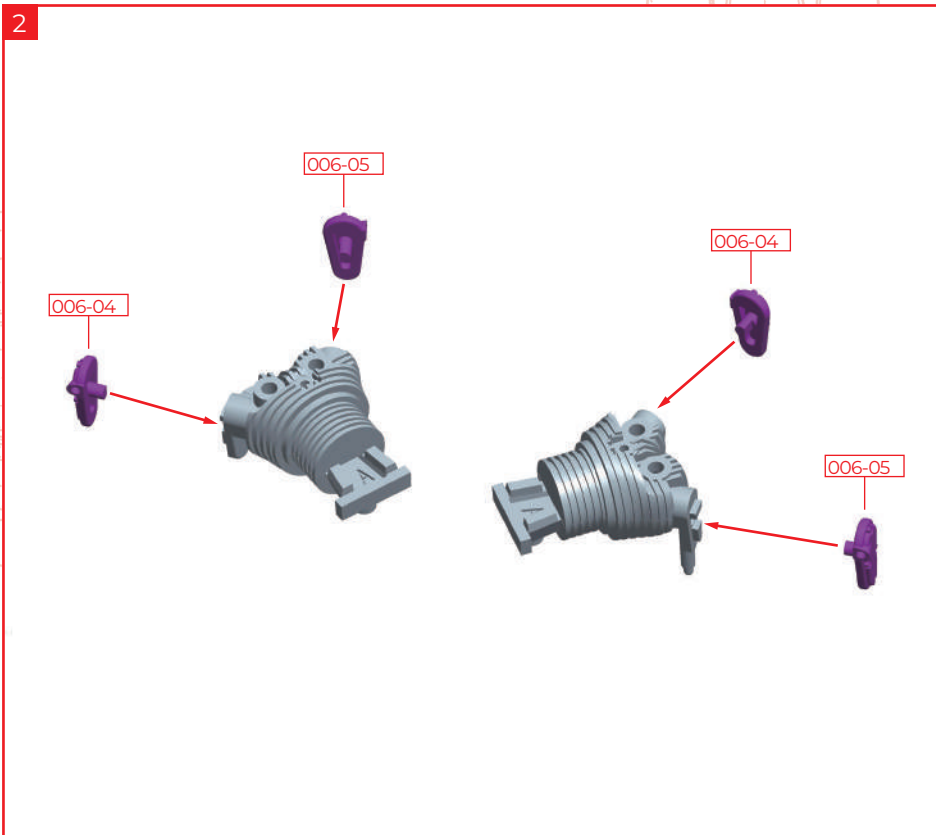
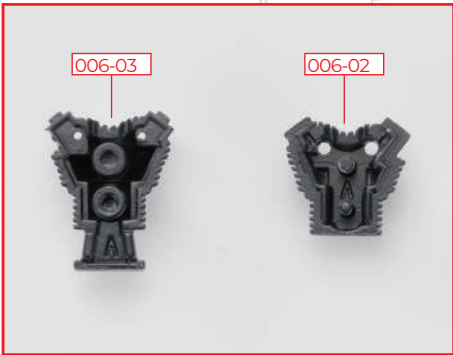

Glue 006-04 & 006-05 to the cylinder assembled in 1. Make two of these. Note that 006-04 & 006-05 are similar in shape.

NOTE
 Glue 006-04 & 006-05 so that the holes on the sides face outward.

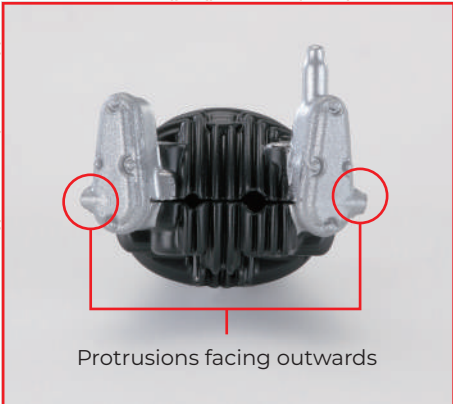

STEP 2

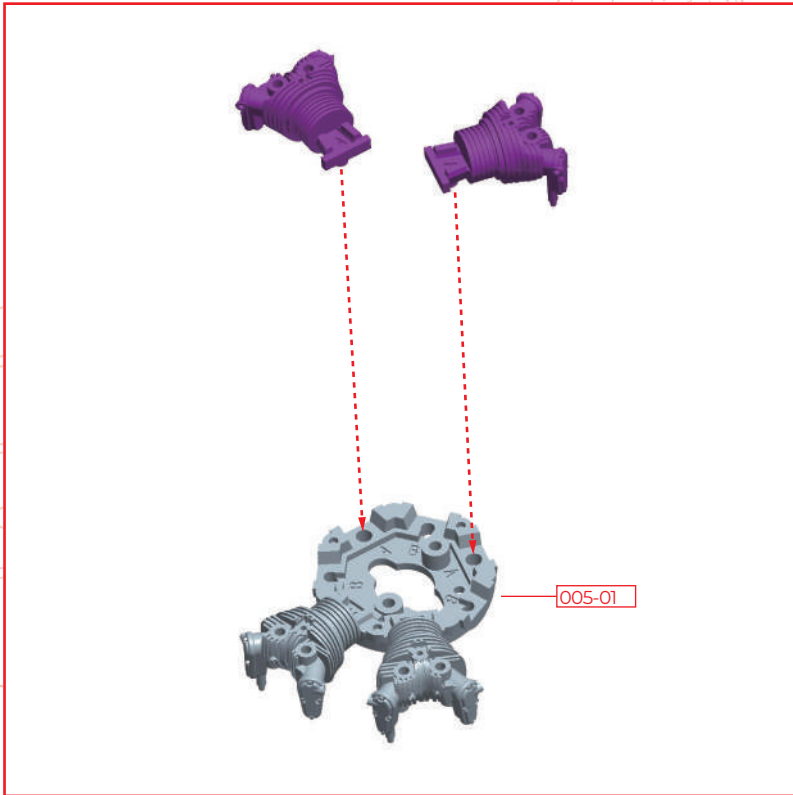

Insert the protrusions on the cylinder from STEP 1 into the hole marked A on the crankcase 005-01 assembled in Stage 05. Do not glue.

NOTE

Each cylinder fits in this position.

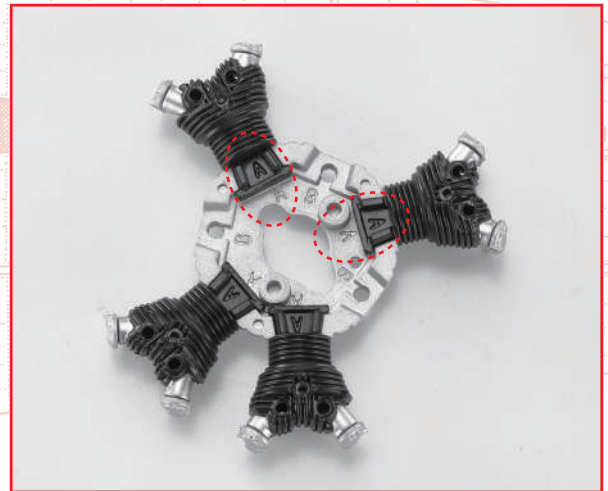

STEP 3

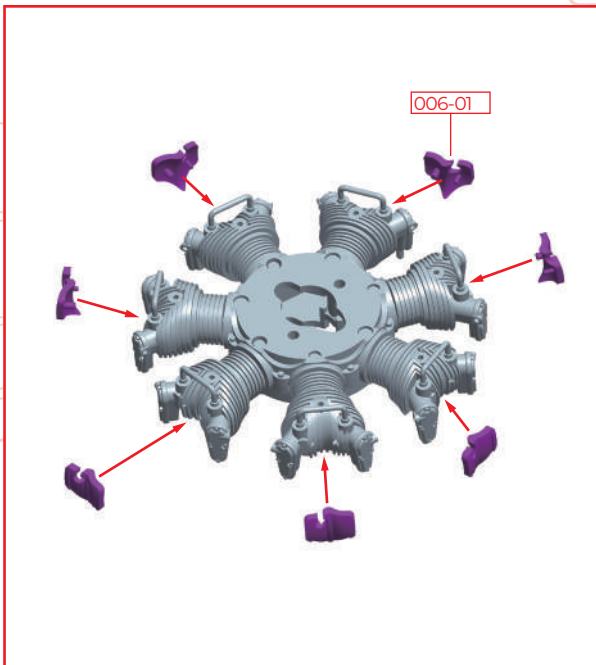

Glue 006-01 to each cylinder of the other assembly from stage 04. Pay attention to the vertical orientation.

STAGE COMPLETE



Stage 07: Building the Engine

Stage 07 Assembly

The Engine



STAGE 07 PARTS

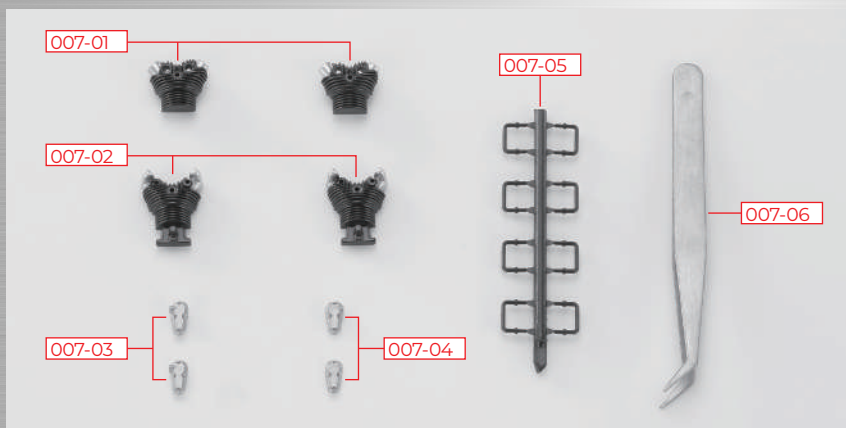

You will also need: superglue
 Parts 007-05 will not be used in this stage. Keep them in a safe place.
 Please use the 007-06 tweezers for assembly.

PARTS LIST

	PART	No.	MATERIAL
<input type="checkbox"/>	007-01	2	Die-cast
<input type="checkbox"/>	007-02	2	Die-cast
<input type="checkbox"/>	007-03	2	ABS resin
<input type="checkbox"/>	007-04	2	ABS resin
<input type="checkbox"/>	007-05	8 (1 spare)	ABS resin
<input type="checkbox"/>	007-06	1	Steel

STEP 1

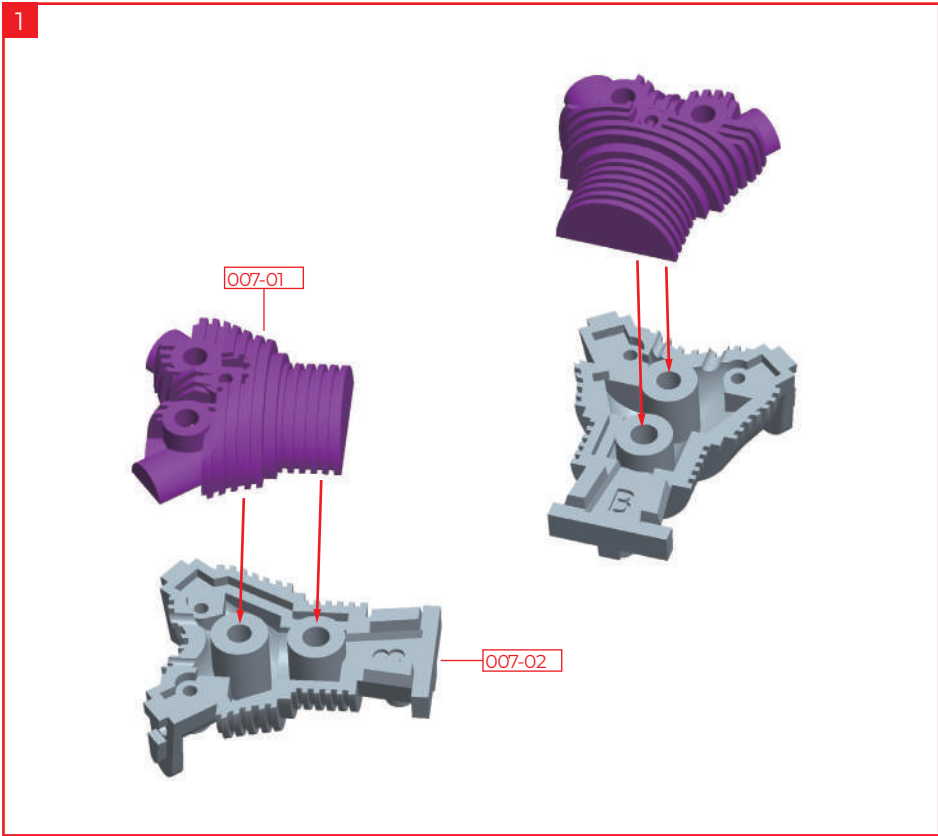

← : Glue
 - - - : Don't Glue

Apply a small amount of superglue to the two pins on part **007-01** and insert them into the holes on part **007-02** to join them. Make two of these.

NOTE
 Cylinders **007-01** & **007-02** are engraved with the letter B.

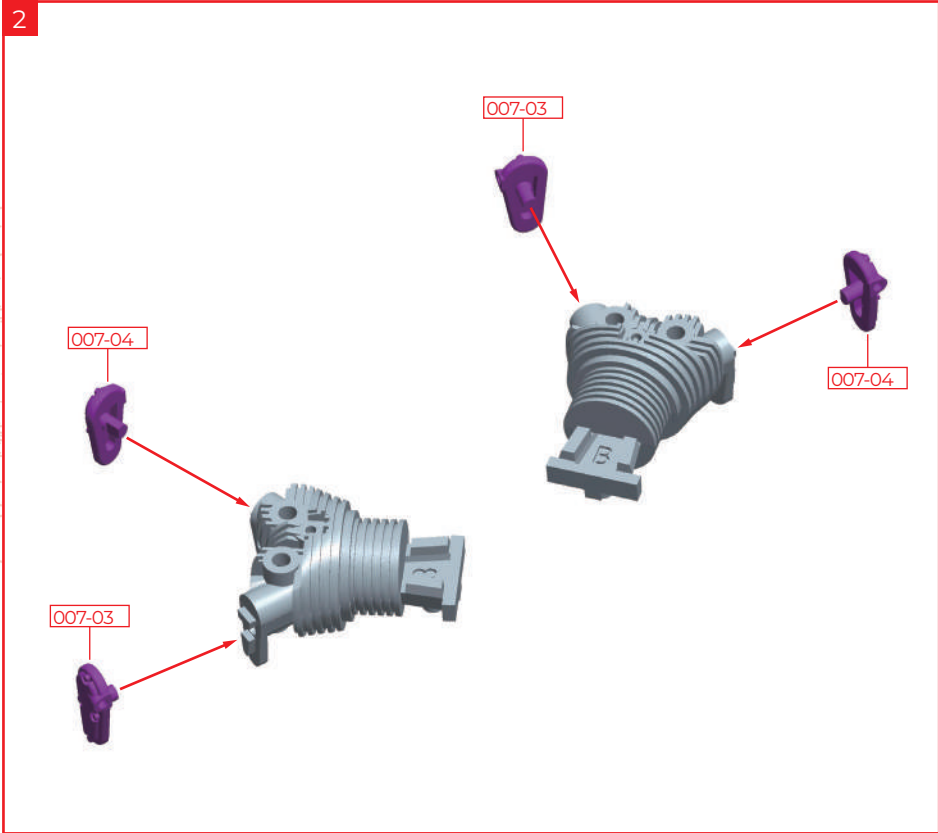
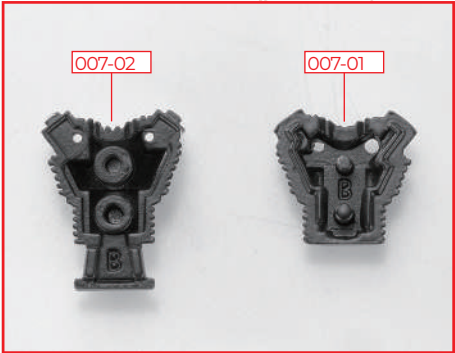

Glue **007-03** & **007-04** to the cylinder assembled in 1. Make two of these. Note that **007-03** & **007-04** are similar in shape.

NOTE
 Glue **007-03** & **007-04** so that the holes on the sides face outward.

STEP 2

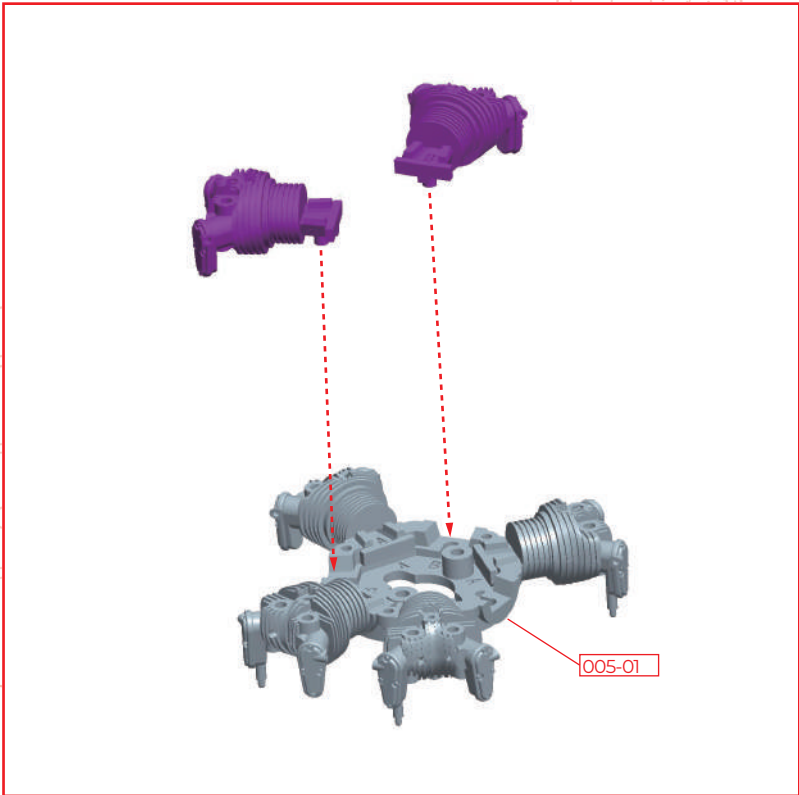

Insert the protrusion of the cylinder assembled in STEP 1 into the hole marked B on the crankcase 005-01 assembled in stage 06. Do not glue.

NOTE
Each cylinder fits in this position.



STAGE COMPLETE

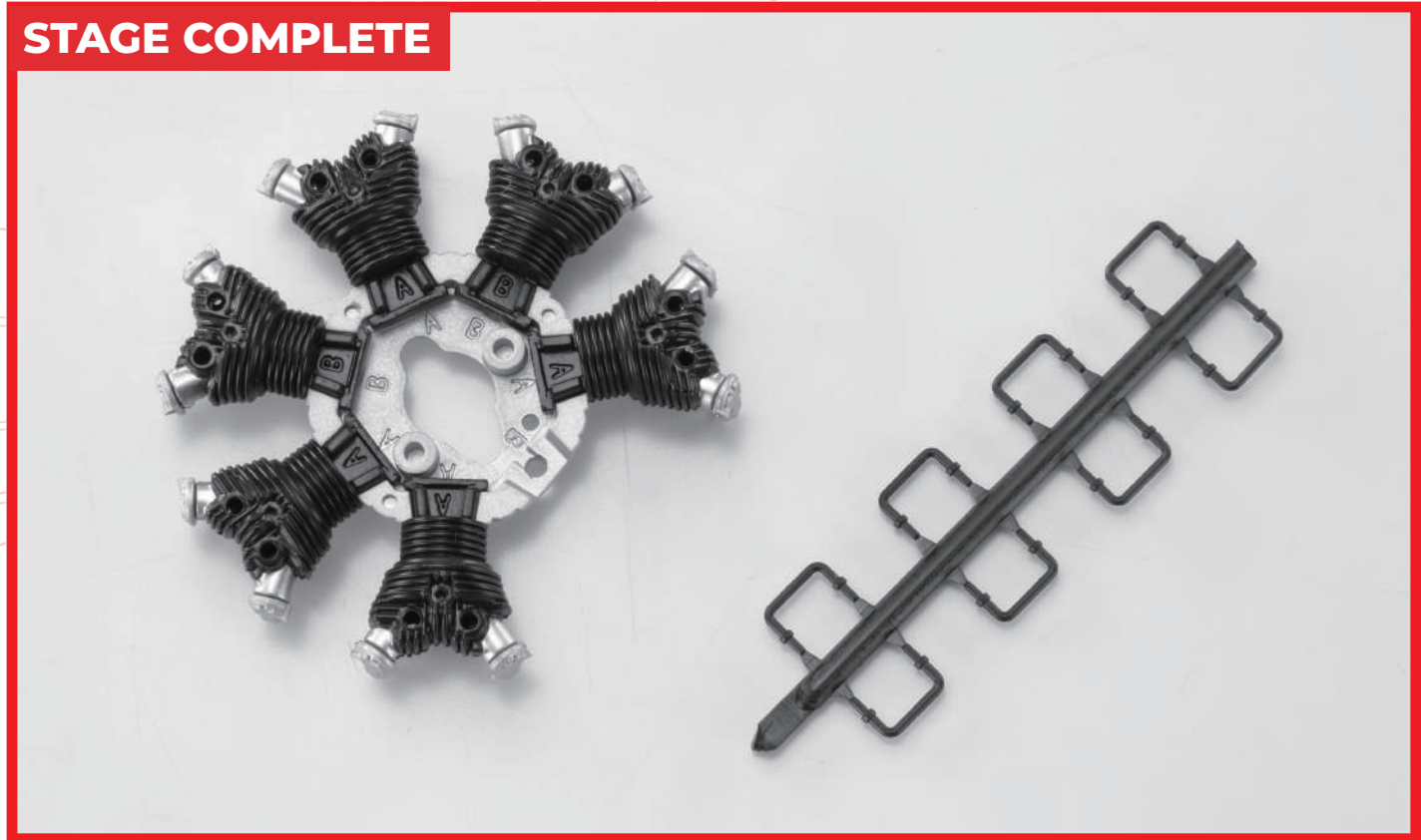

Stage 08: Building the Engine

Stage 08 Assembly

The Engine



STAGE 08 PARTS

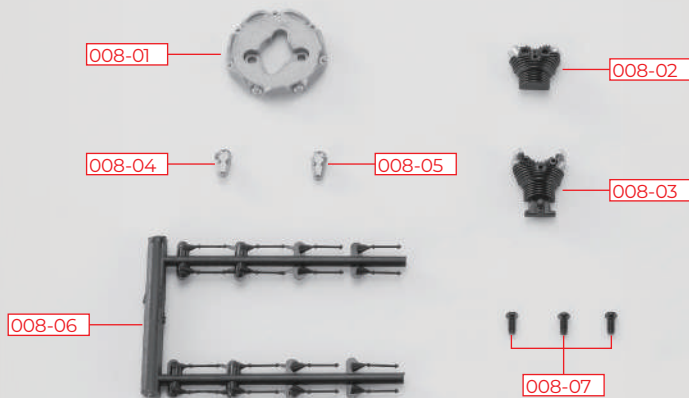

You will also need: superglue, tweezers, cutter, screwdriver

PARTS LIST

	PART	No.	MATERIAL
<input type="checkbox"/>	008-01	1	Die-cast
<input type="checkbox"/>	008-02	1	Die-cast
<input type="checkbox"/>	008-03	1	Die-cast
<input type="checkbox"/>	008-04	1	ABS resin
<input type="checkbox"/>	008-05	1	ABS resin
<input type="checkbox"/>	008-06	16 (2 spares)	ABS resin
<input type="checkbox"/>	008-07	3 (1 spare)	Steel

STEP 1

Assembling the cylinders

← : Glue
 - - - : Don't Glue

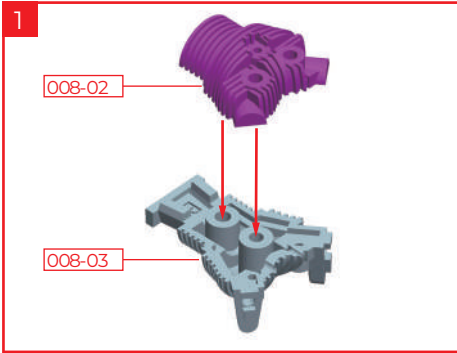

NOTE

Cylinders 008-02 & 008-03 are marked with the letter B.

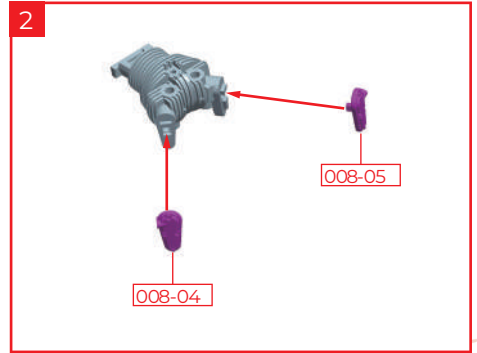

Apply a small amount of superglue to the two pins on part 008-02 and insert them into the holes on part 008-03 to join them.

Glue rocker boxes 008-04 & 008-05 to the cylinder assembled in 1. Note that 008-04 & 008-05 are similar in shape. Glue each side so that holes on the sides face outward.

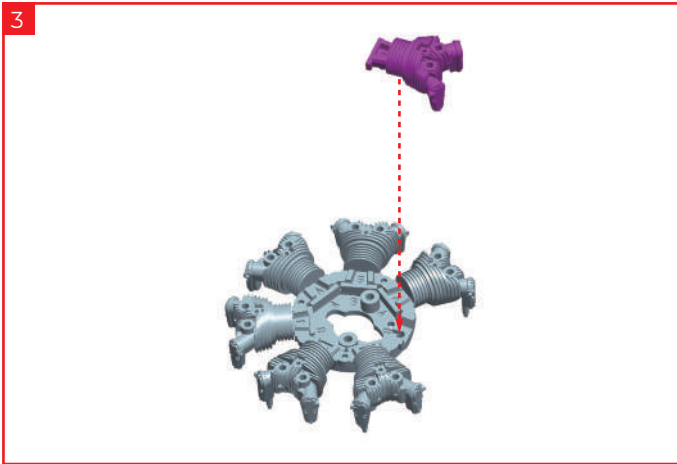

Insert the protrusion of the cylinder assembled in STEP 1 into the hole marked B on the crankcase 005-01 assembled in stage 07. Do not glue.

STEP 2

Attaching the rods to the rocker boxes on the cylinders

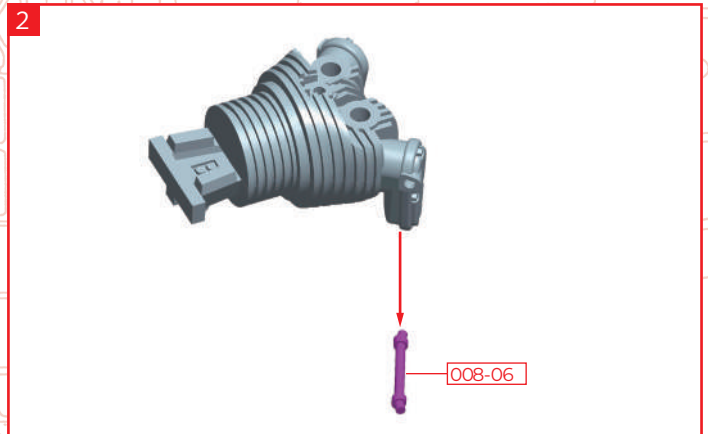

Remove the cylinders from the crankcase and place them next to the holes so that you can see where they were mounted.

Glue rod 008-06 to the outer hole of the rocker box marked B. Cut the rod 008-06 a little longer when disconnecting it from the sprue, and adjust the length when joining it to adjacent cylinders.

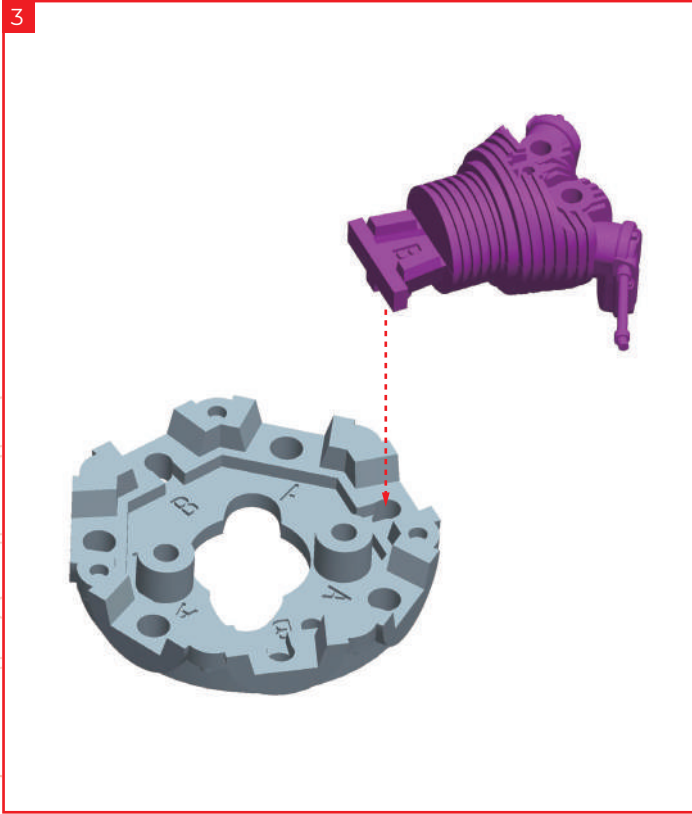

Return the cylinder from 2 to the position shown in the crankcase.

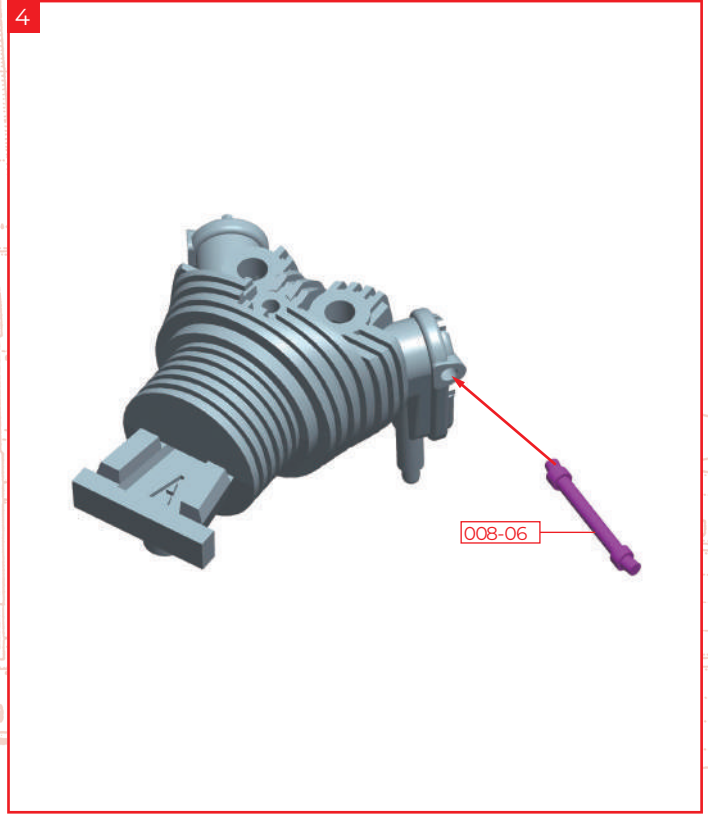

Glue 008-06 to the outer hole on the rocker box marked A to the left of 2.

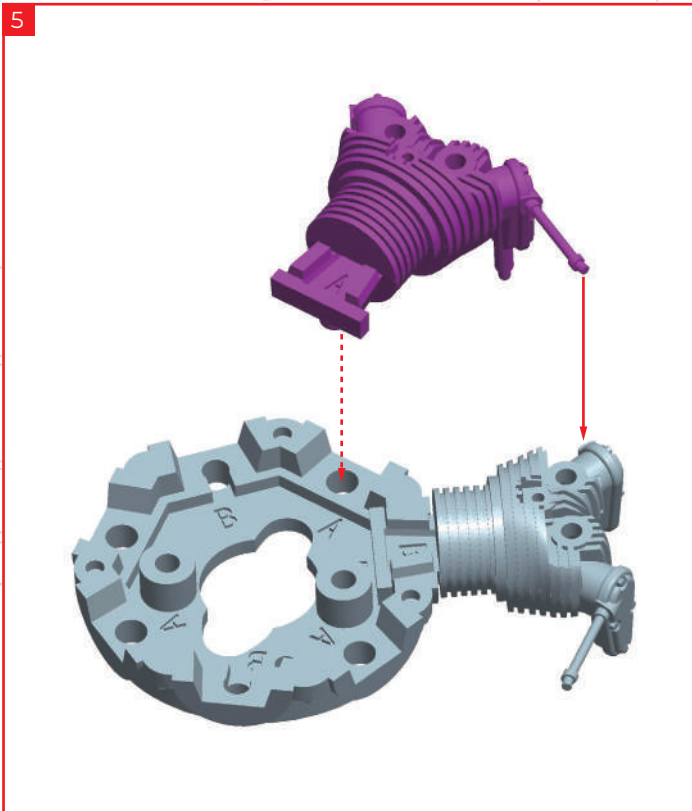

Glue the tip of 008-06 attached in 4 to the hole in the other rocker box that was returned to the crankcase in 3, and return to the position shown on the crankcase.

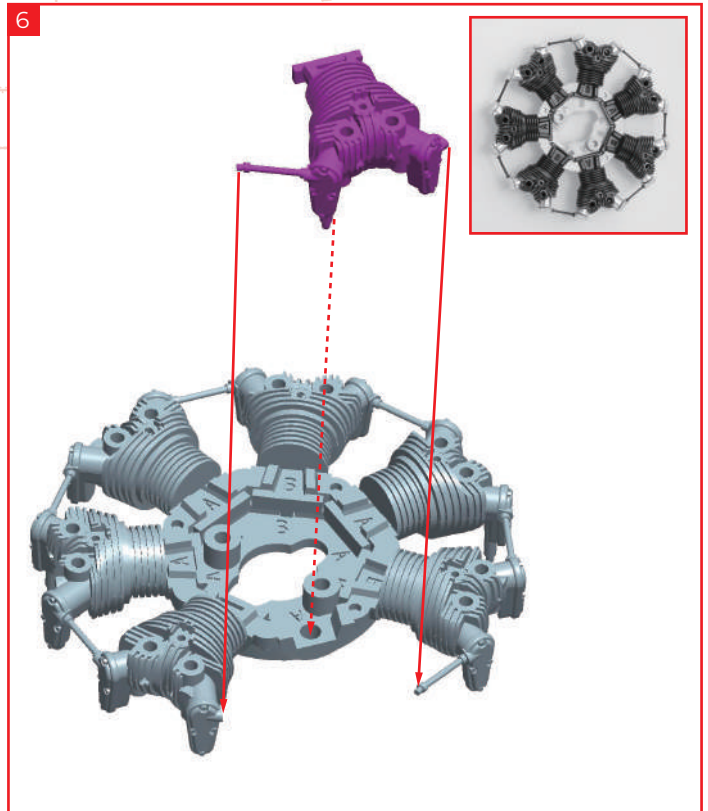

Similarly, glue the remaining parts 008-06 so that they are sandwiched between all the cylinders.

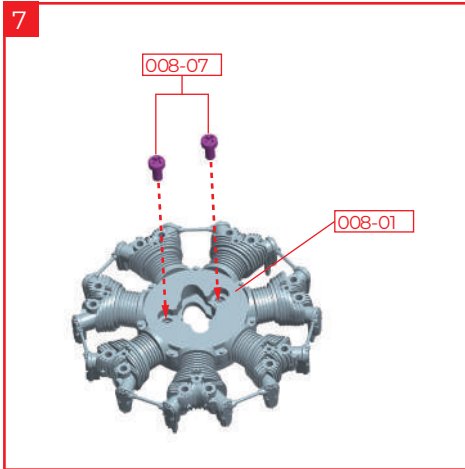

Cover with part 008-01 and fix with the screws 008-07.

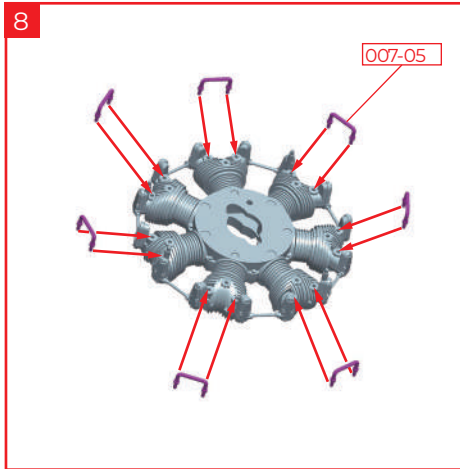

Turn the crankcase over so that the parts 008-04 & 008-05 face upward. Glue 007-05 that came with stage 07 to each cylinder.

NOTE
If 007-05 does not fit well, place a blade on the part that fits in the cylinder and scrape it lightly to thin it. Note that if you apply too much pressure or turn the blade diagonally it will be scraped more than necessary.



STEP 3

Completing the rear cylinder block

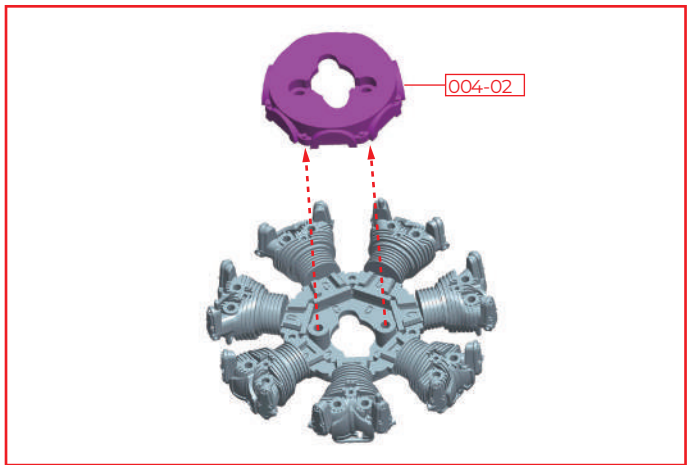
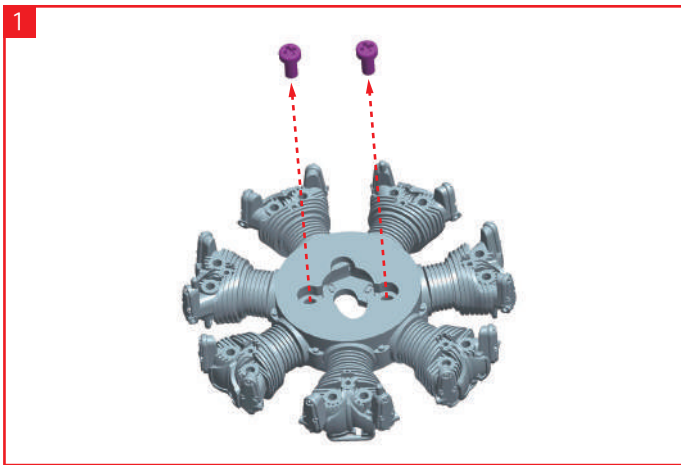

As in STEP 2, we'll attach the rods to the crankcase assembled in stage 04. Remove the screws and part 004-02.

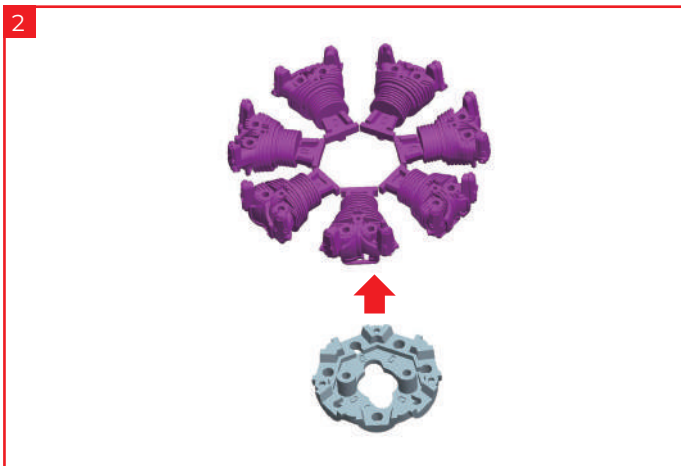

Remove the cylinders and place them next to the holes on the crankcase so that you can see where they are mounted.

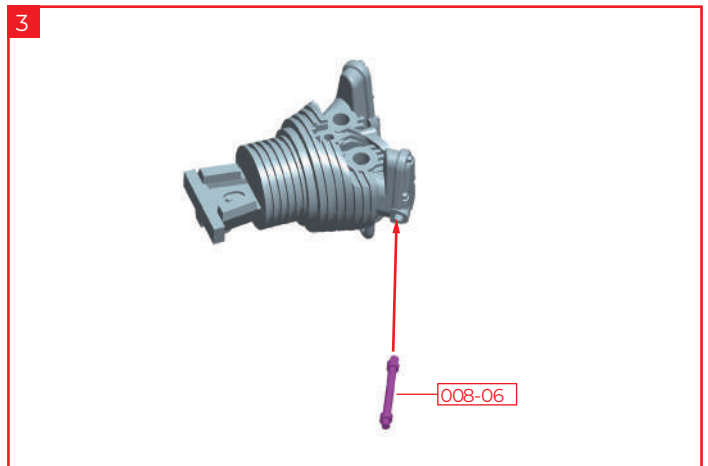

Glue rod 008-06 to the outer hole on the rocker box marked C.

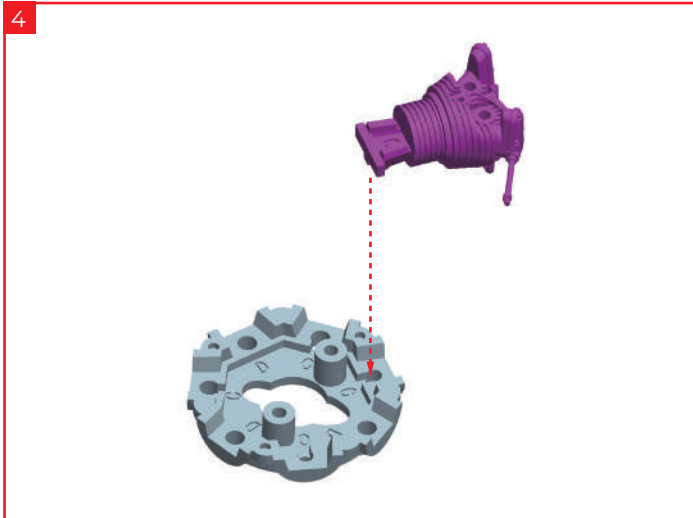

Return 3 to the position shown in the crankcase.

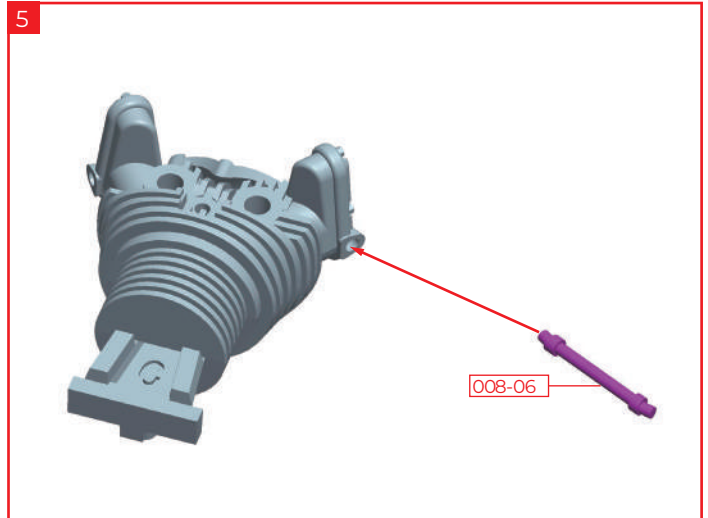

Glue 008-06 to the outer hole of the rocker box marked C on the left of 3.

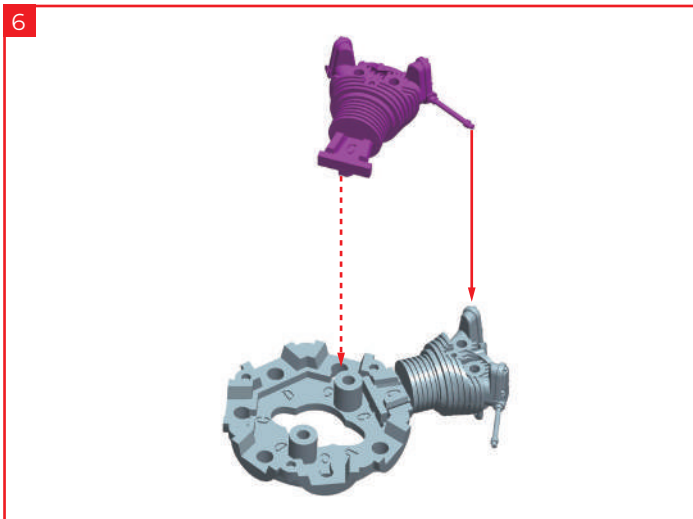

Glue the tip of 008-06 attached in 5 to the other rocker box returned to the crankcase in 4, and return it to the position shown.

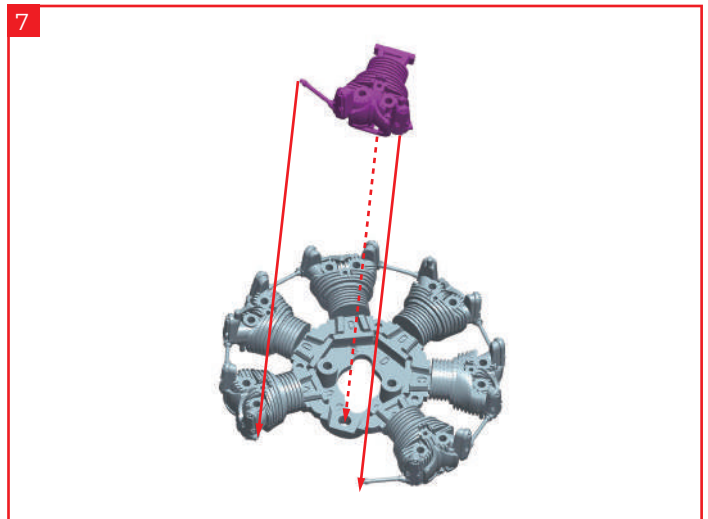

Similarly, glue the remaining five 008-06 parts so that they are sandwiched between all the cylinders.

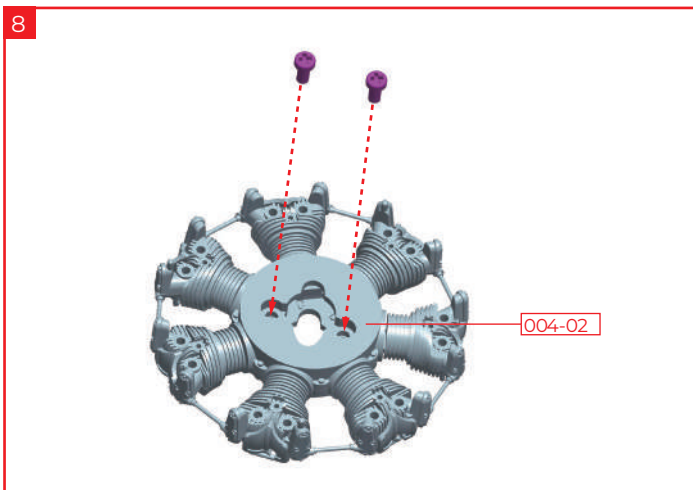

Replace the cover part 004-02 and fix it with the removed screws.



Stage 09: Building the Engine

Stage 09 Assembly

The Engine



STAGE 09 PARTS

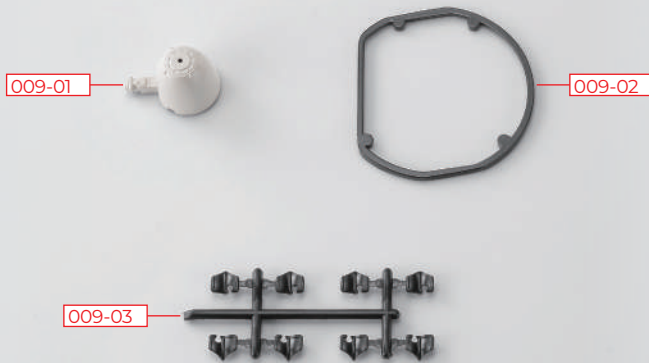

PARTS LIST

	PART	No.	MATERIAL
<input type="checkbox"/>	009-01	1	ABS resin
<input type="checkbox"/>	009-02	1	Die-cast
<input type="checkbox"/>	009-03	8 (1 spare)	ABS resin

You will also need: superglue, tweezers
 Parts 009-01 & 009-02 will not be used in this stage. Keep them in a safe place.

STEP 1

← : Glue
- - - : Don't Glue

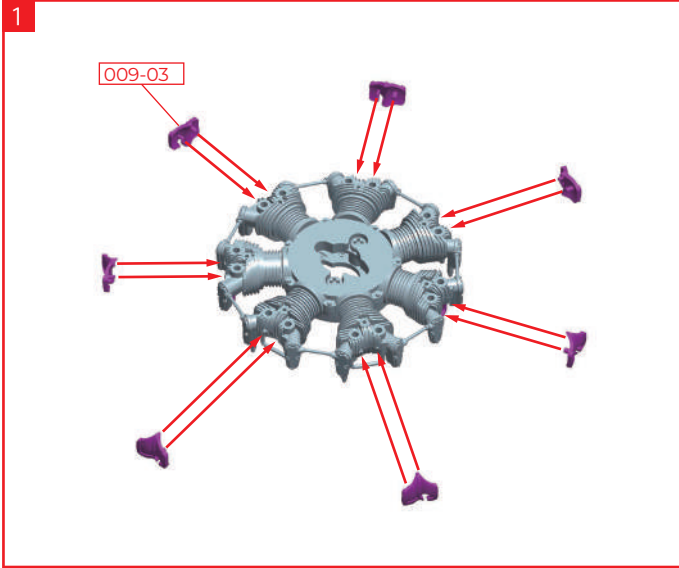

Glue parts 009-03 to each cylinder assembled in stage 08.

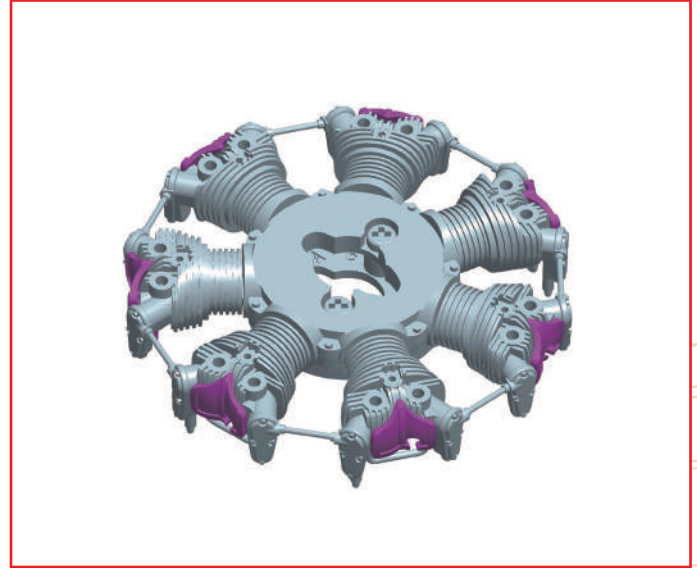

Pay attention to the orientation of the part when gluing.



Be careful not to leave a gap between 009-03 and the cylinder.

STAGE COMPLETE



Stage 10: Building the Engine: Manifold

Stage 10 Assembly

The Engine

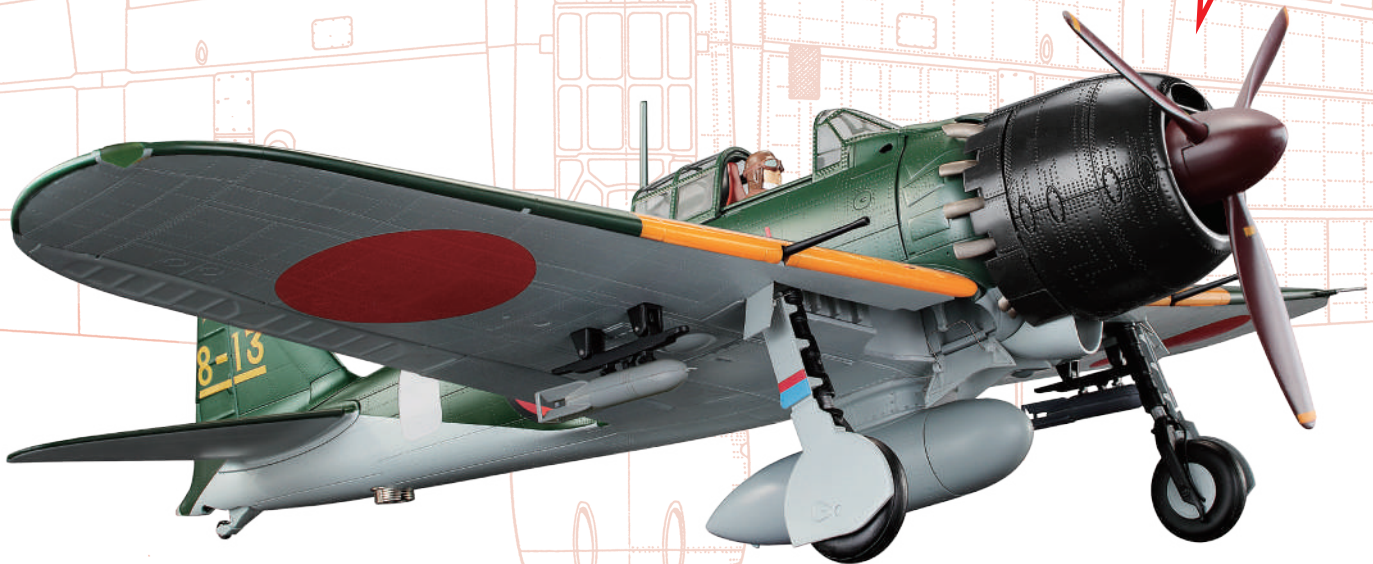

STAGE 10 PARTS

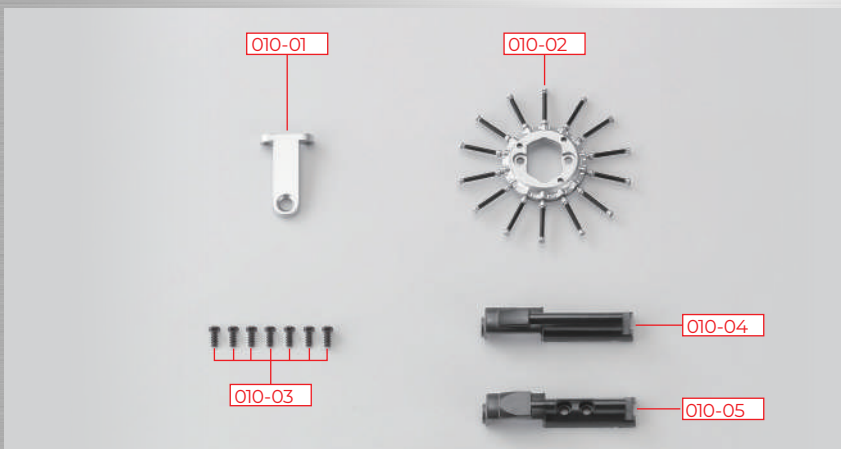

Parts 010-02, 010-03, 010-04, 010-05 will not be used in this stage. Keep them in a safe place.

PARTS LIST

	PART	No.	MATERIAL
<input type="checkbox"/>	010-01	1	ABS resin
<input type="checkbox"/>	010-02	1	ABS resin
<input type="checkbox"/>	010-03	7	Steel
<input type="checkbox"/>	010-04	1	ABS resin
<input type="checkbox"/>	010-05	1	ABS resin

STEP 1

← : Glue
- - - : Don't Glue

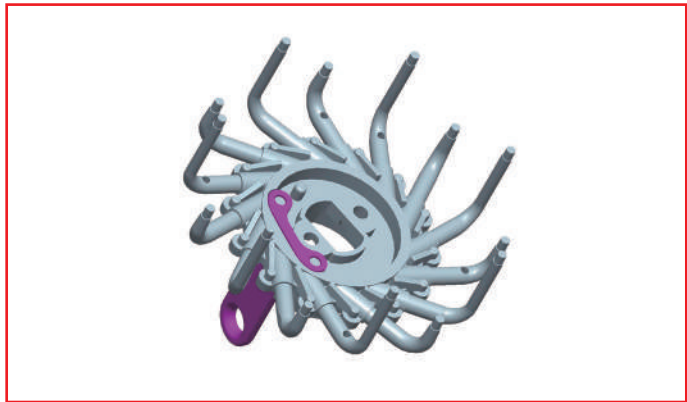
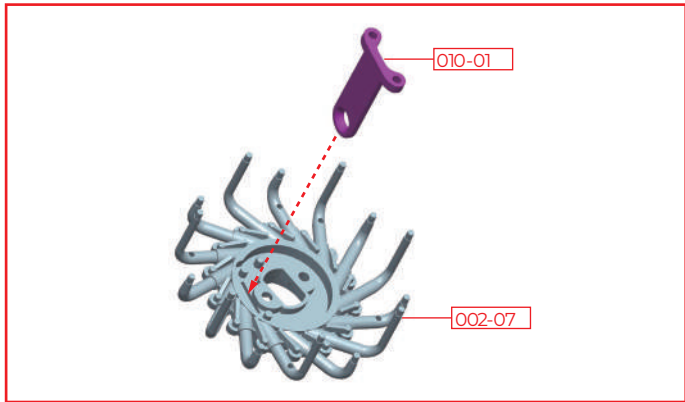

Insert 010-01 into part 002-07 that came in stage 02.



NOTE
010-01 is easy to insert if you hold it as shown in the picture and push it with your thumb. be careful not to damage the surrounding piping.

STAGE COMPLETE



Stage 11: Building the Engine: Plug Cord

Stage 11 Assembly

The Engine



STAGE 11 PARTS

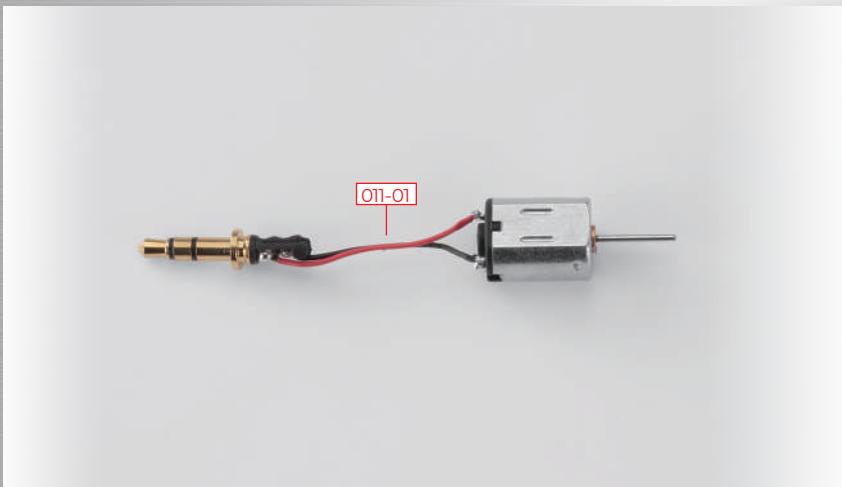

You will also need: superglue, screwdriver, tweezers.

PARTS LIST

	PART	No.	MATERIAL
<input type="checkbox"/>	011-01	1	Motor

STEP 1

Assembling the motor unit

← : Glue
- - - : Don't Glue

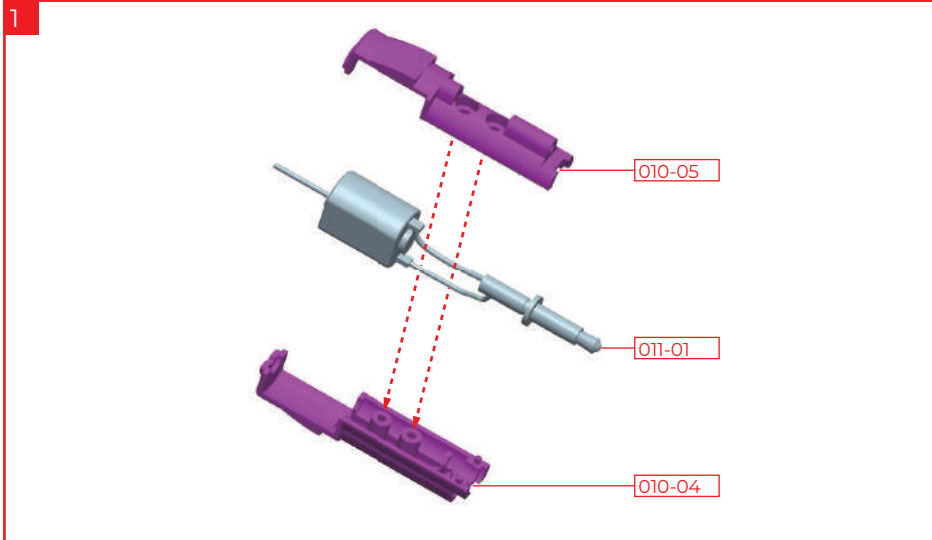

NOTE
Now is a good time to test that the motor is working before you assemble the engine. To do this, connect the motor 011-01 to part 015-06 from stage 15, then connect to the 012-01 battery box. Insert batteries to check that the motor turns.

To start building the engine, sandwich part 011-01 between parts 010-04 and 010-05 that came in stage 10.

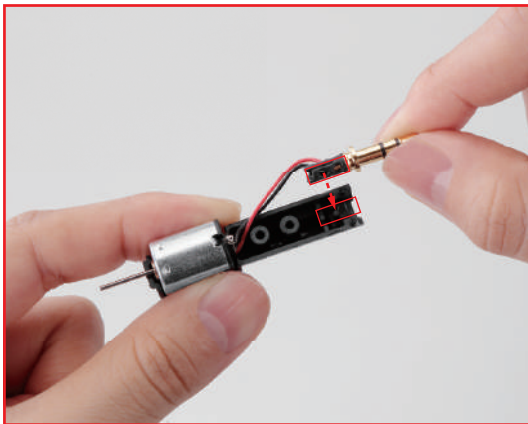

NOTE
This shows the correct position for the jack. Also check that the two lugs on part 010-05 are firmly fitted into the two holes on part 010-04.

NOTE
Check that the wire runs in the gap around the screw holes.

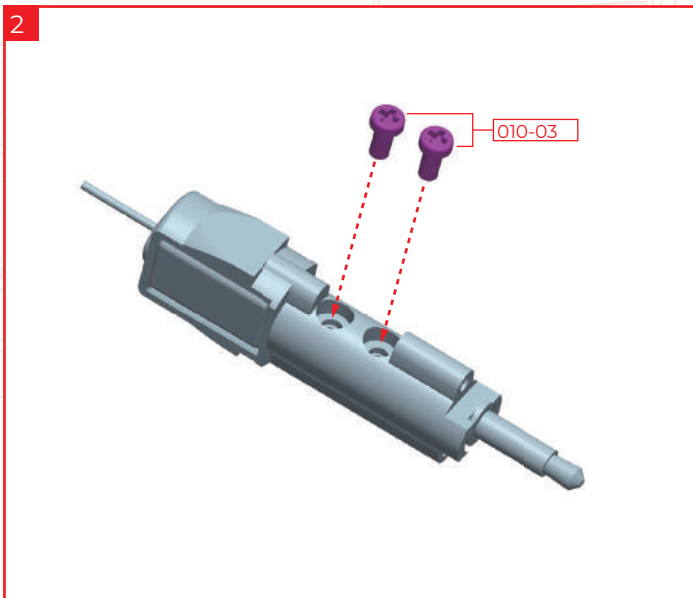
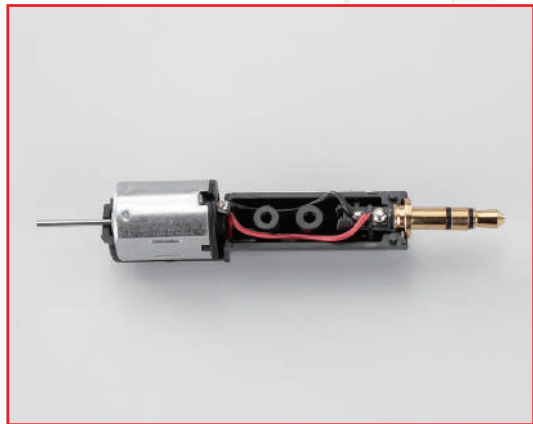

Fix the parts together using 2 x 010-03 screws.

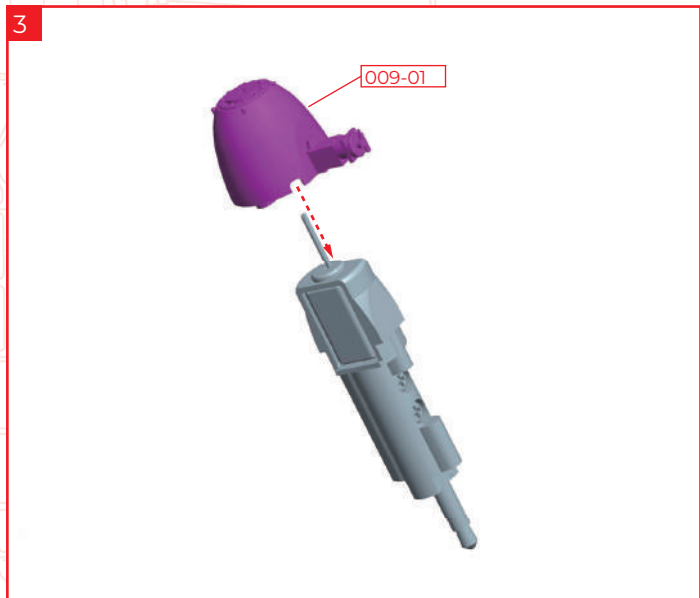

Attach the spinner 009-01 that came in stage 09 to the assembly in 2.

STEP 2

Mounting the plug cords

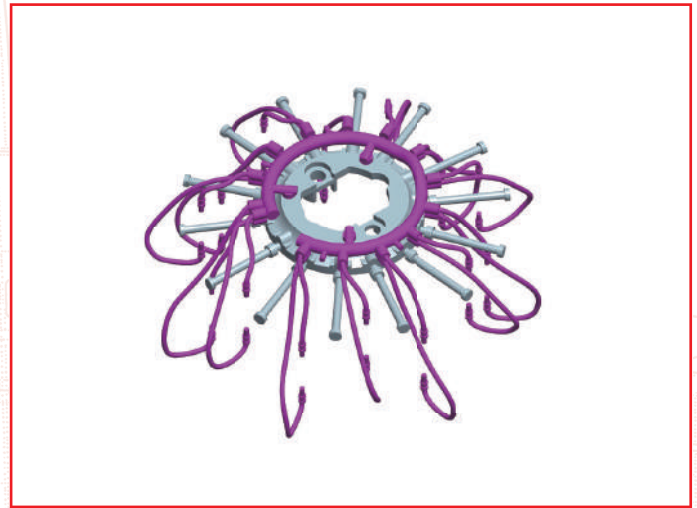
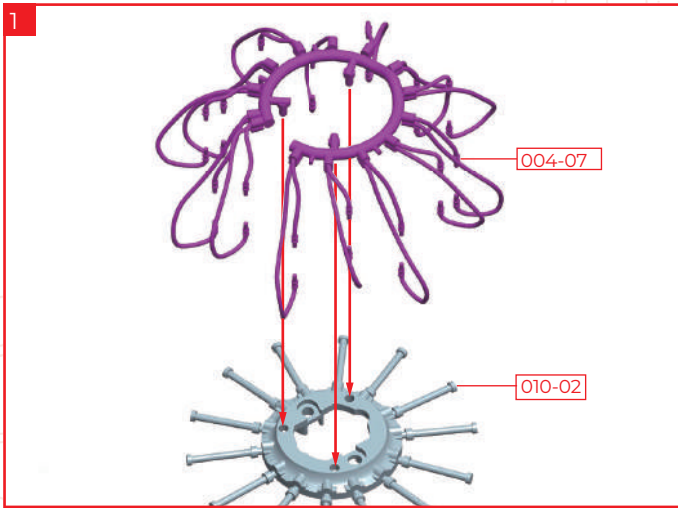

Insert the pins of 004-07 (from stage 04) into the three holes of 010-02 (from stage 10), paying attention to the orientation of both parts.

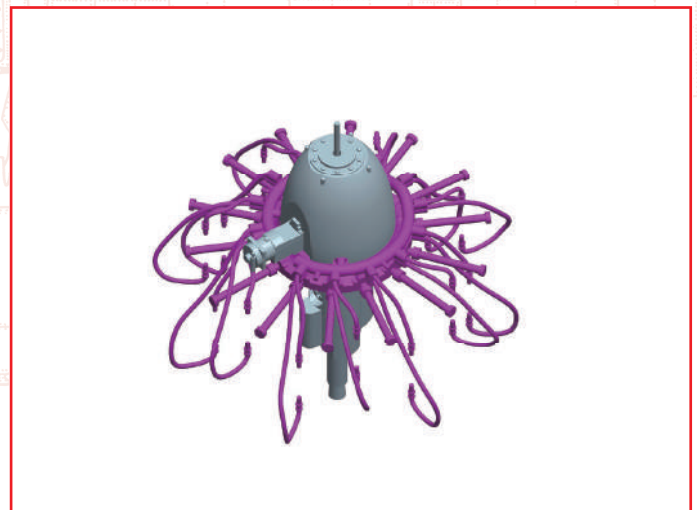
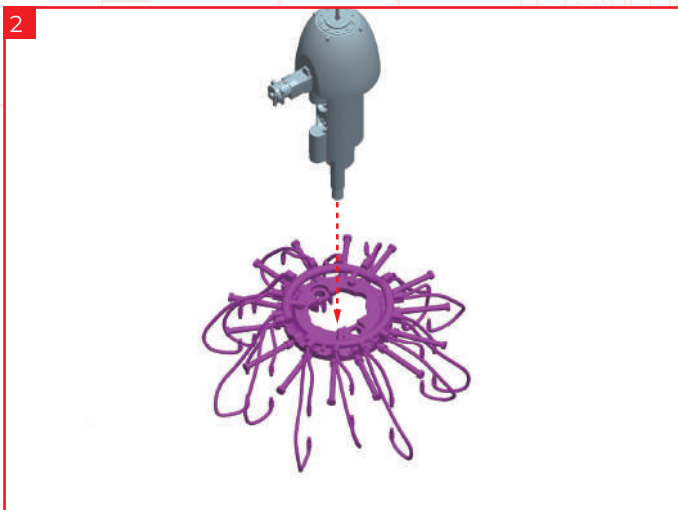

Insert the unit assembled in STEP 1 into the assembly in 1, again paying attention to the orientation of both parts.

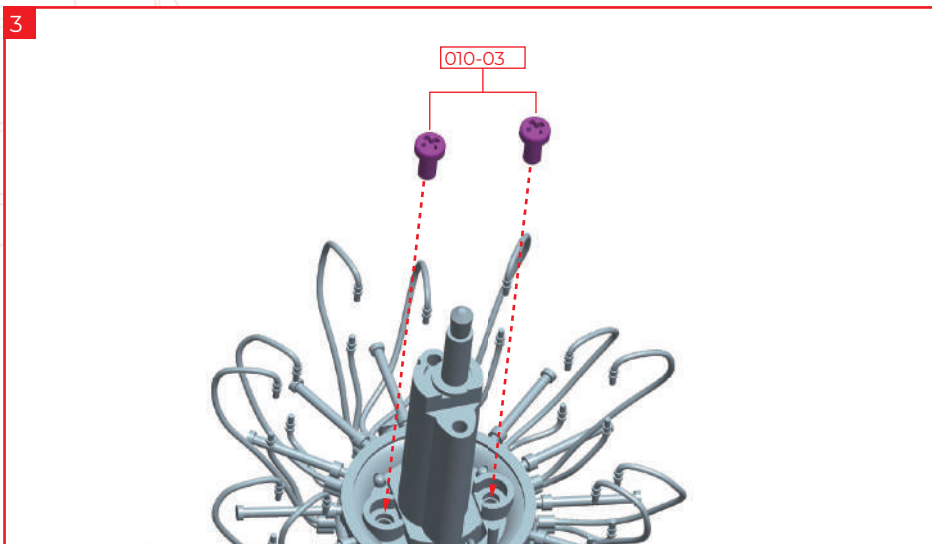

Fix in place from the reverse side using 2 x 010-03 screws.

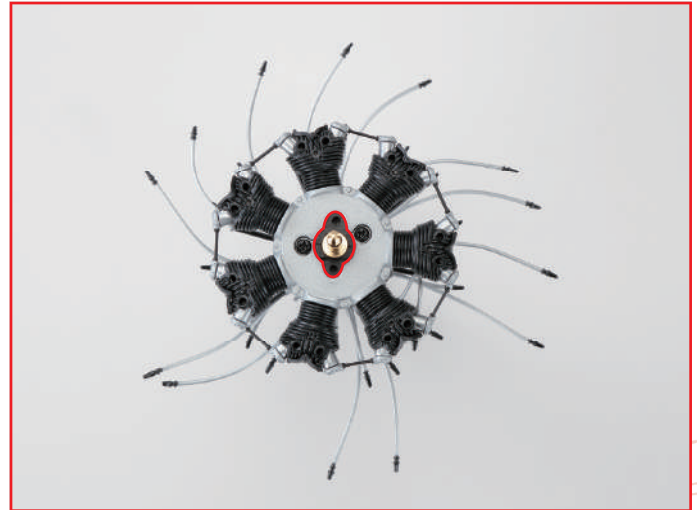
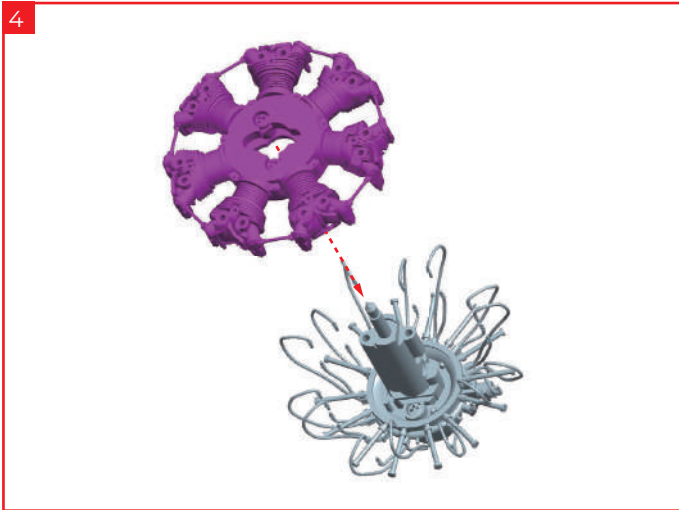

Take the cylinder block from stage 09 and insert the assembly from 3 through the centre. Check you have the correct assembly in the correct orientation by carefully studying the diagrams.

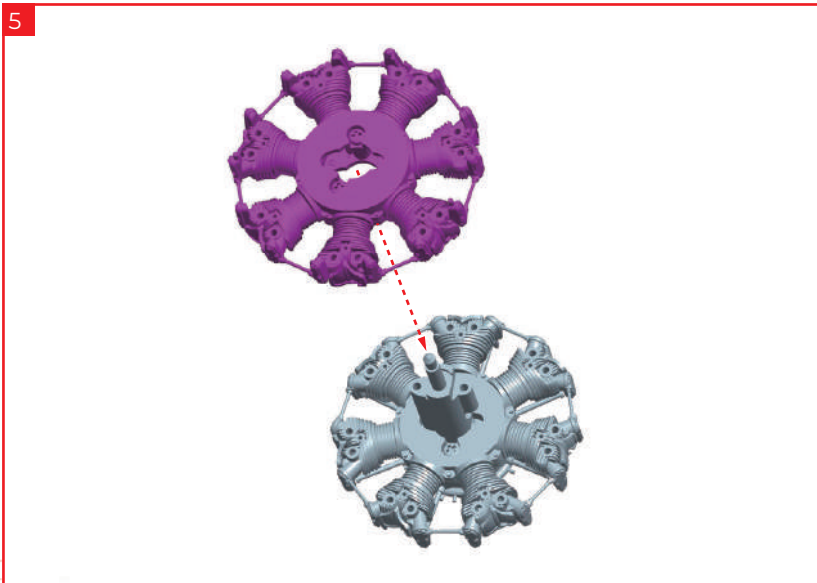

Insert the assembly from stage 08 on top of 4.

NOTE

The cylinder blocks assembled in stages 08 and 09 are similar. Study the pictures below to check you have the correct assemblies. Ensure they are pushed together all the way along the motor assembly.

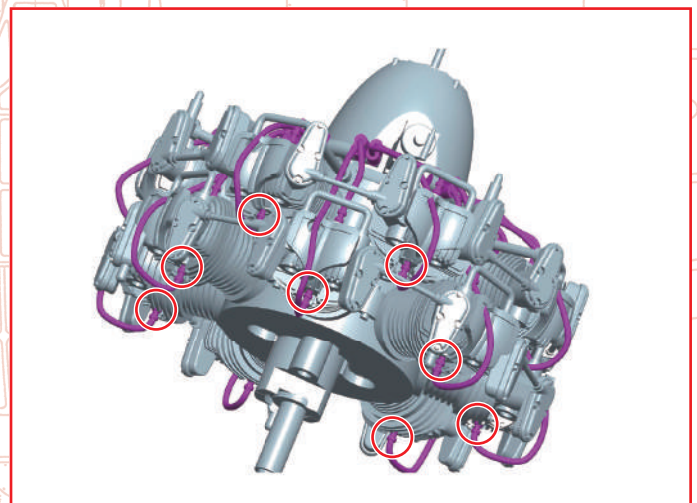
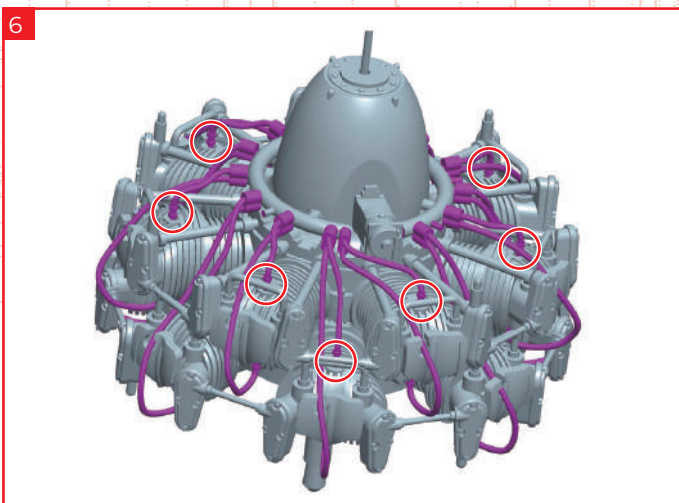
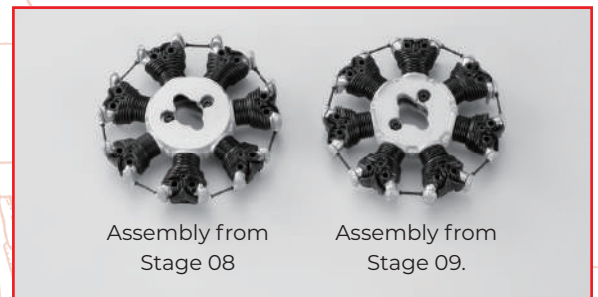

Insert the ends of 004-07 into each cylinder. The shorter piece goes into the hole on the top of the cylinder, and the longer one bends into a U shape and is inserted into the hole underneath the cylinder.

STEP 3

Mounting the rod wheel

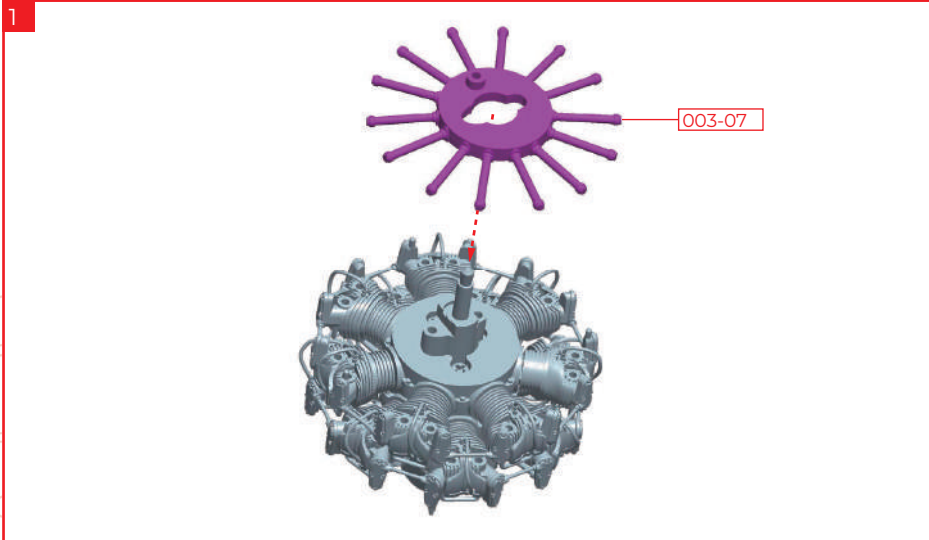

Attach the rod wheel 003-07 from stage 03 to the assembly from STEP 2.

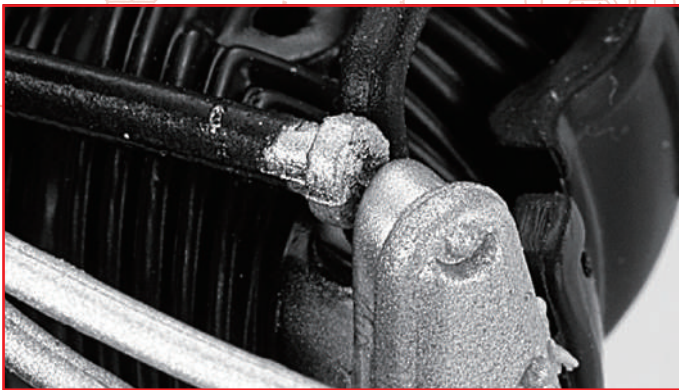

NOTE

Make sure that the tip of the rod does not stick out from the silver parts of the engine. Push it lightly to correct if necessary.

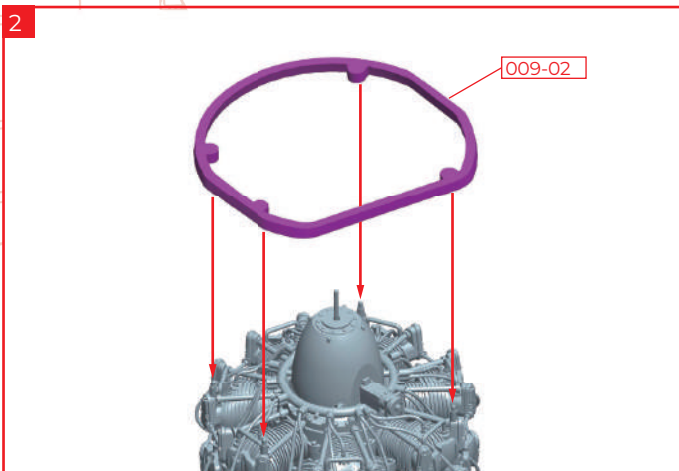

Glue the four holes on the frame part 009-02 from stage 09 to the protrusions on the cylinder.

STAGE COMPLETE



Stage 12: Building the Engine: Mount Ring

Stage 12 Assembly

The Engine



STAGE 12 PARTS

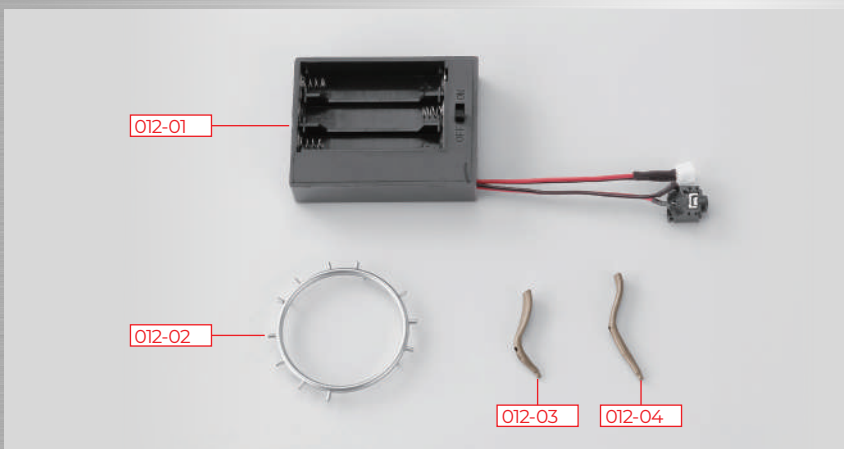

Please note: the connectors on the battery box may look different to those shown here.

You will also need: superglue, tweezers. Parts 012-01, 012-03, 012-04 will not be used in this stage. Keep them in a safe place.

PARTS LIST

	PART	No.	MATERIAL
<input type="checkbox"/>	012-01	1	Plastic
<input type="checkbox"/>	012-02	1	ABS resin
<input type="checkbox"/>	012-03	1	ABS resin
<input type="checkbox"/>	012-04	1	ABS resin

STEP 1

Attaching the mount ring for the exhaust pipe to the manifold

← : Glue
 ← : Don't Glue

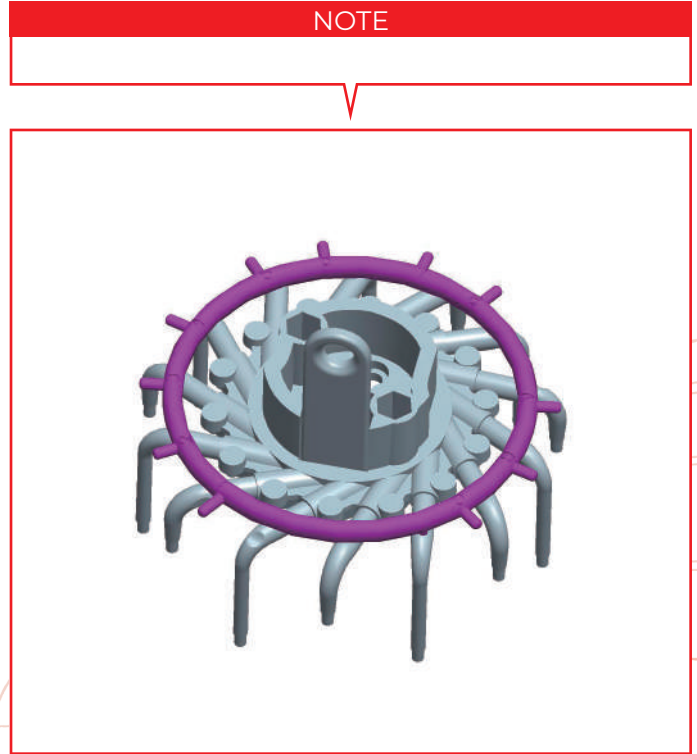
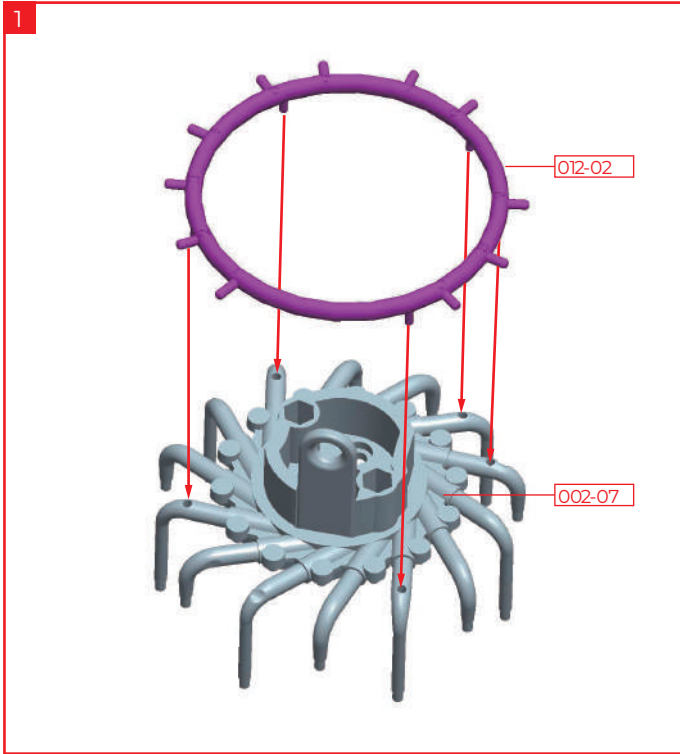

Glue the five pegs on the mount ring part 012-02 to the five holes on the manifold 002-07 assembled in stage 10. Scrape off all the paint from the 14 tips of part 002-07 to ensure they'll fit into parts at a later stage.

STAGE COMPLETE

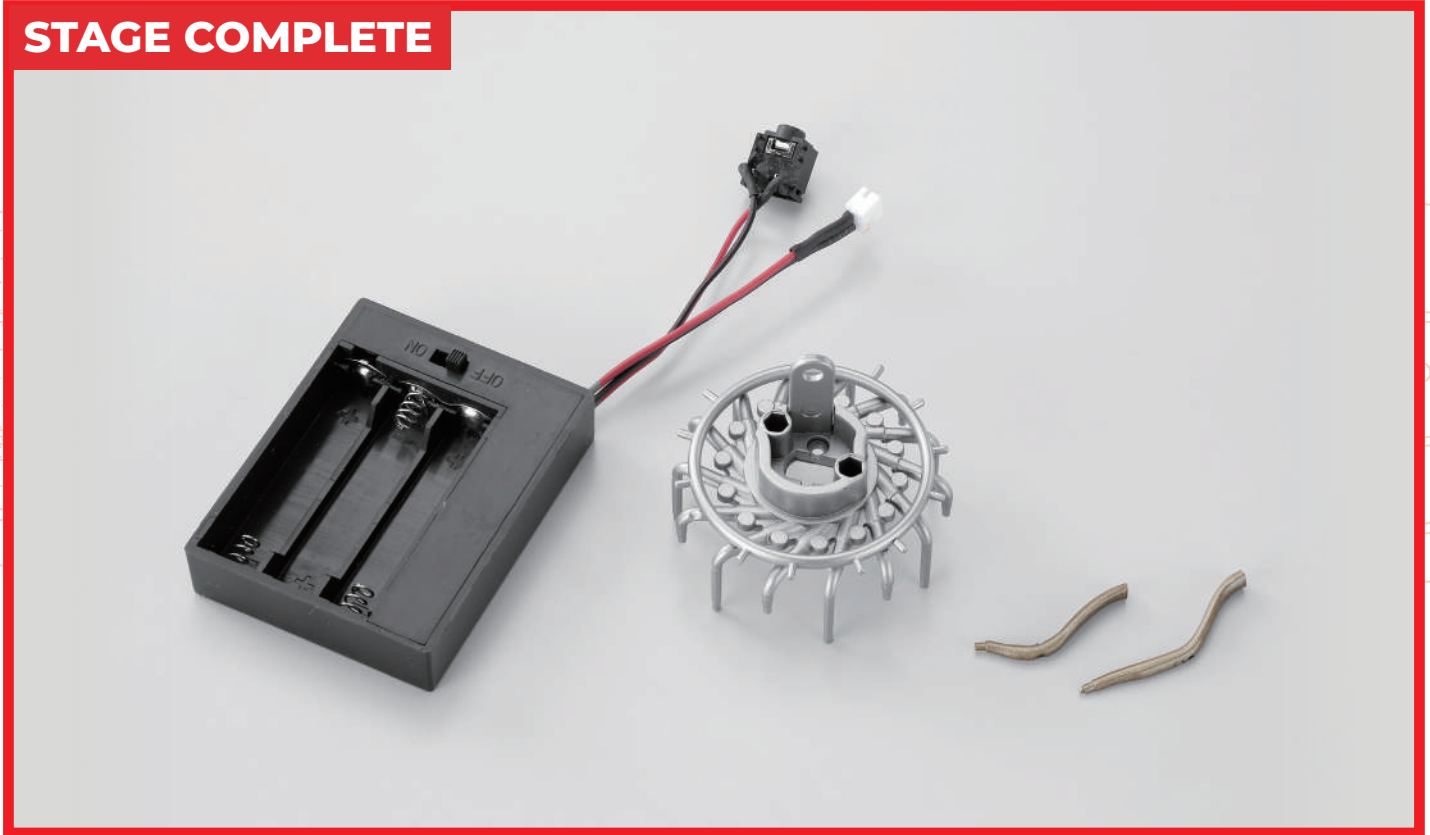

Stage 13: Building the Engine: Cowl Flap

Stage 13 Assembly

The Engine



STAGE 13 PARTS

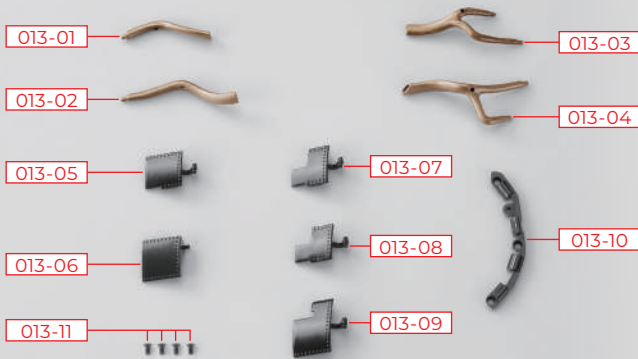

You will also need: superglue, screwdriver, tweezers
 Parts 013-01, 013-02, 013-03, 013-04 will not be used in this stage. Keep them in a safe place.

PARTS LIST

	PART	No.	MATERIAL
<input type="checkbox"/>	013-01	1	ABS resin
<input type="checkbox"/>	013-02	1	ABS resin
<input type="checkbox"/>	013-03	1	ABS resin
<input type="checkbox"/>	013-04	1	ABS resin
<input type="checkbox"/>	013-05	1	ABS resin
<input type="checkbox"/>	013-06	1	ABS resin
<input type="checkbox"/>	013-07	1	ABS resin
<input type="checkbox"/>	013-08	1	ABS resin
<input type="checkbox"/>	013-09	1	ABS resin
<input type="checkbox"/>	013-10	1	ABS resin
<input type="checkbox"/>	013-11	4 (1 spare)	Steel

STEP 1

Assembling the cowl flap

← : Glue
 - - - : Don't Glue

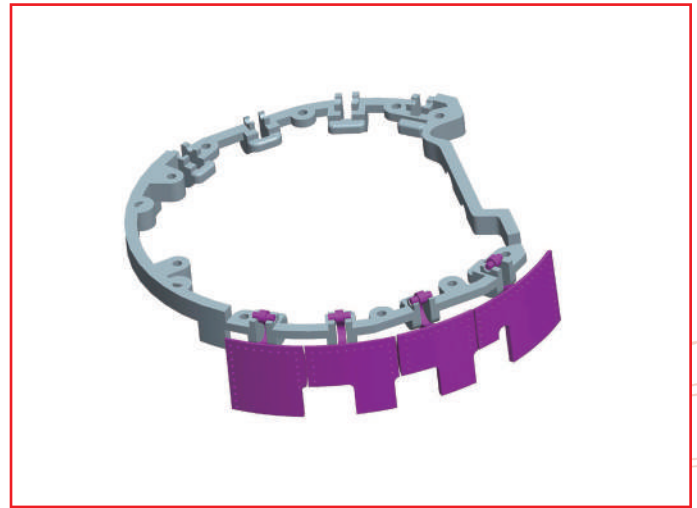
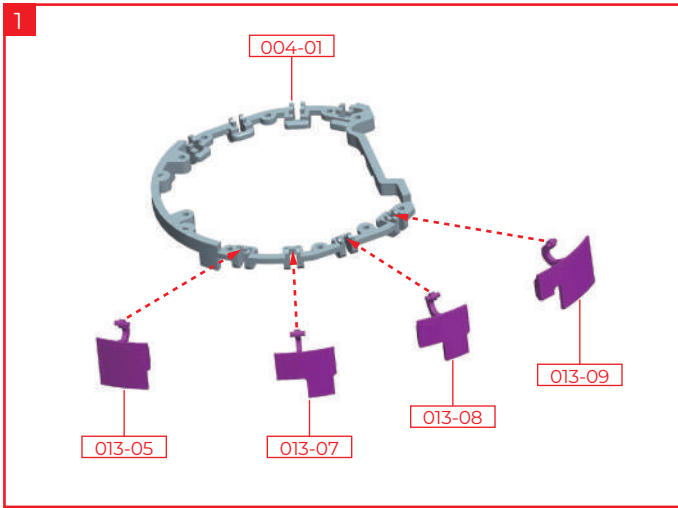

Fit 013-05, 013-07, 013-08, 013-09 into the engine frame 004-01 that came with stage 04. Do not glue these parts as they open and close.

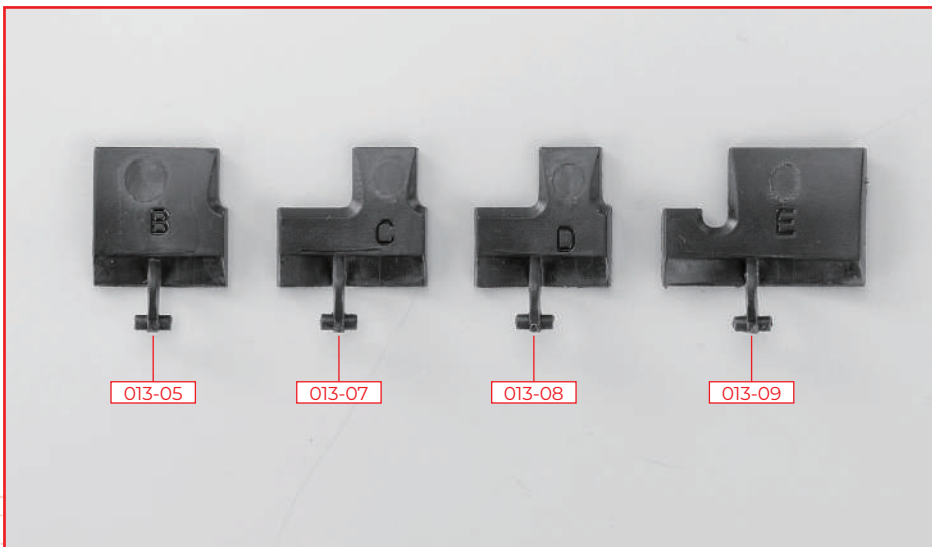

NOTE
 013-05, 013-07, 013-08, 013-09 are marked with B, C, D, and E respectively. The shapes are similar so don't make a mistake.

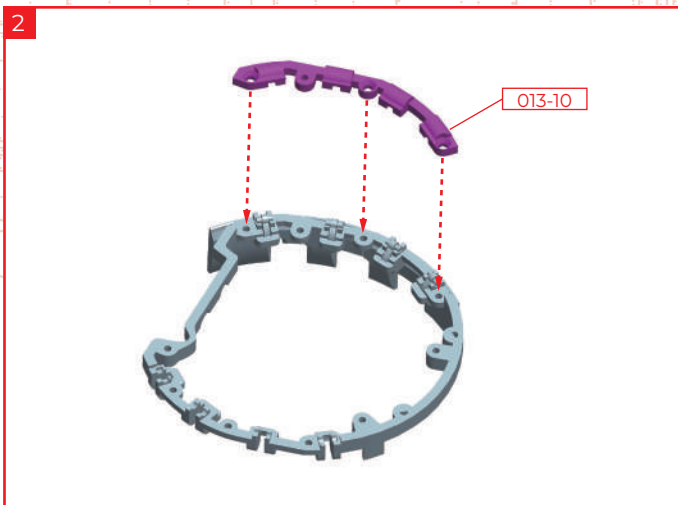

Lower the hinge cover part 013-10 onto the frame in 1.

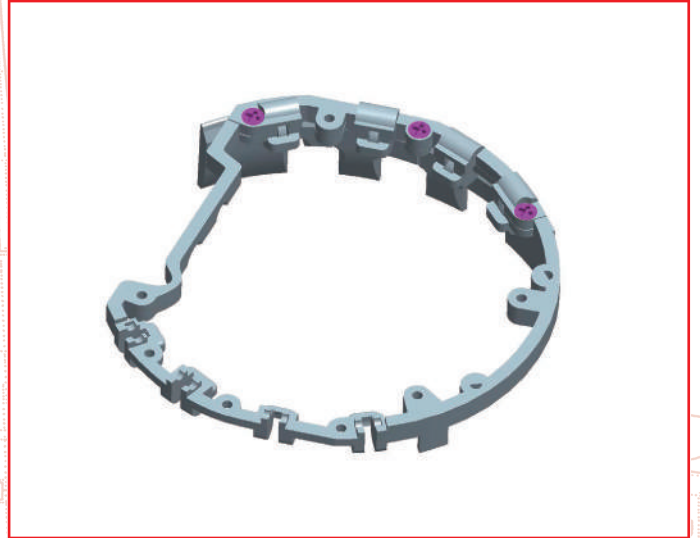
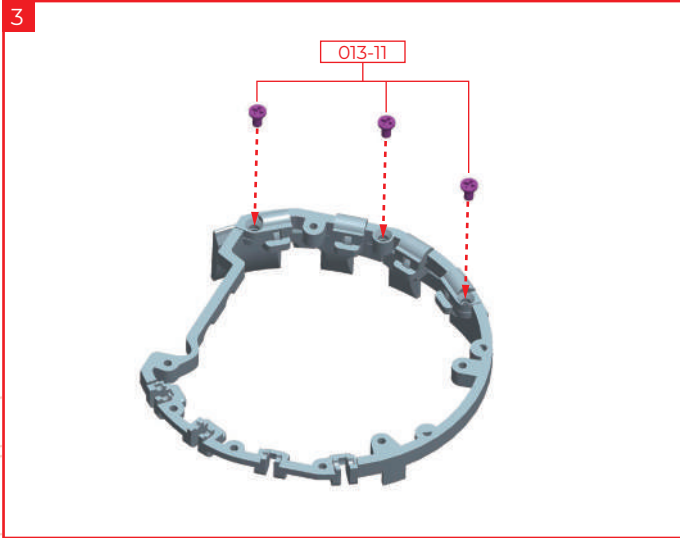

Fix 013-10 in place using 3 x 013-11 screws. Note that the second hole from the left is not screwed.

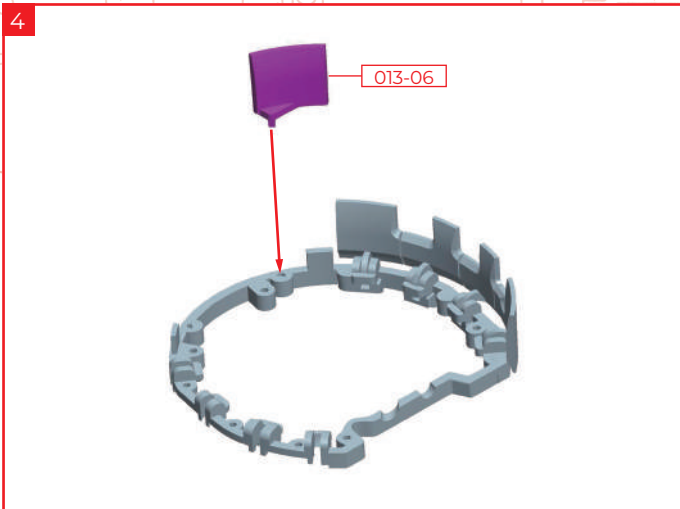

NOTE
Part 013-06 is marked with the letter A.

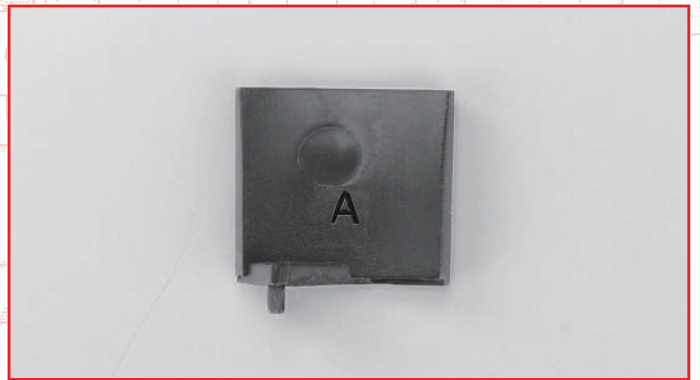

Turn 3 over and glue the pin of 013-06 to the hole on the left of 013-05. This flap doesn't move.

STAGE COMPLETE



Stage 14: Building the Engine: Cowl Flap

Stage 14 Assembly

The Engine



STAGE 14 PARTS

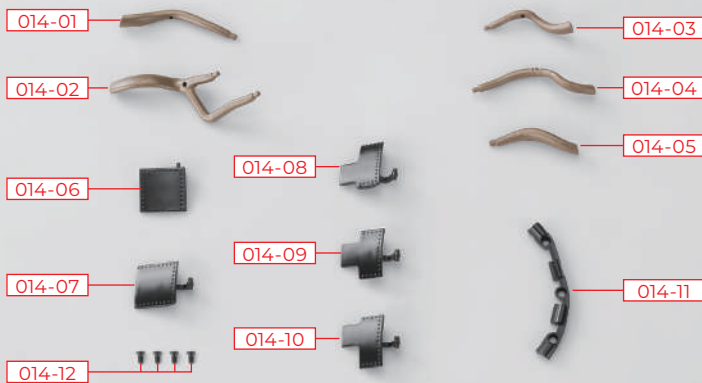

You will also need: superglue, screwdriver, tweezers.

PARTS LIST

	PART	No.	MATERIAL
<input type="checkbox"/>	014-01	1	ABS resin
<input type="checkbox"/>	014-02	1	ABS resin
<input type="checkbox"/>	014-03	1	ABS resin
<input type="checkbox"/>	014-04	1	ABS resin
<input type="checkbox"/>	014-05	1	ABS resin
<input type="checkbox"/>	014-06	1	ABS resin
<input type="checkbox"/>	014-07	1	ABS resin
<input type="checkbox"/>	014-08	1	ABS resin
<input type="checkbox"/>	014-09	1	ABS resin
<input type="checkbox"/>	014-10	1	ABS resin
<input type="checkbox"/>	014-11	1	ABS resin
<input type="checkbox"/>	014-12	4 (1 spare)	Steel

STEP 1

Assembling the cowl flap

← : Glue
 - - - : Don't Glue

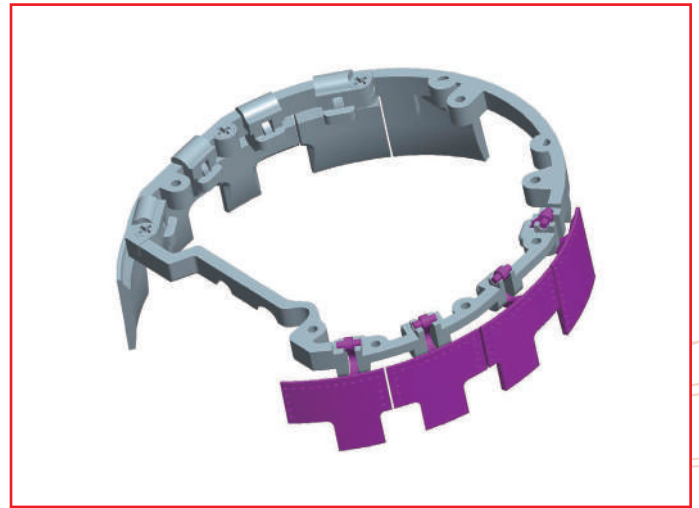
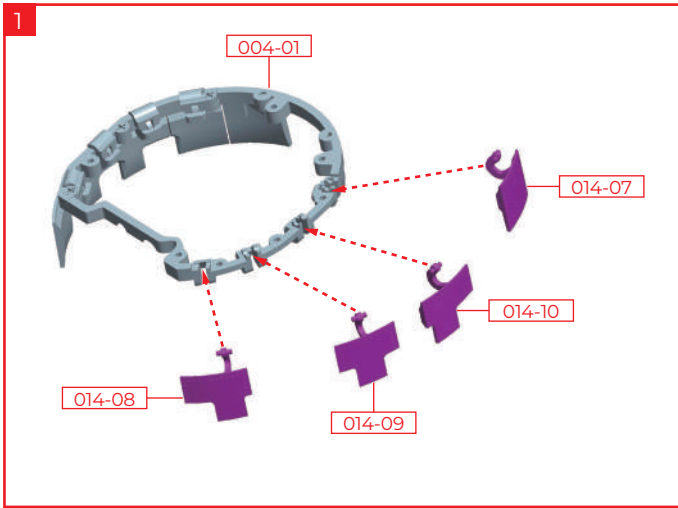

Attach 014-08, 014-09, 014-10, 014-07 to the parts assembled in stage 13. Do not glue these parts as they open and close.

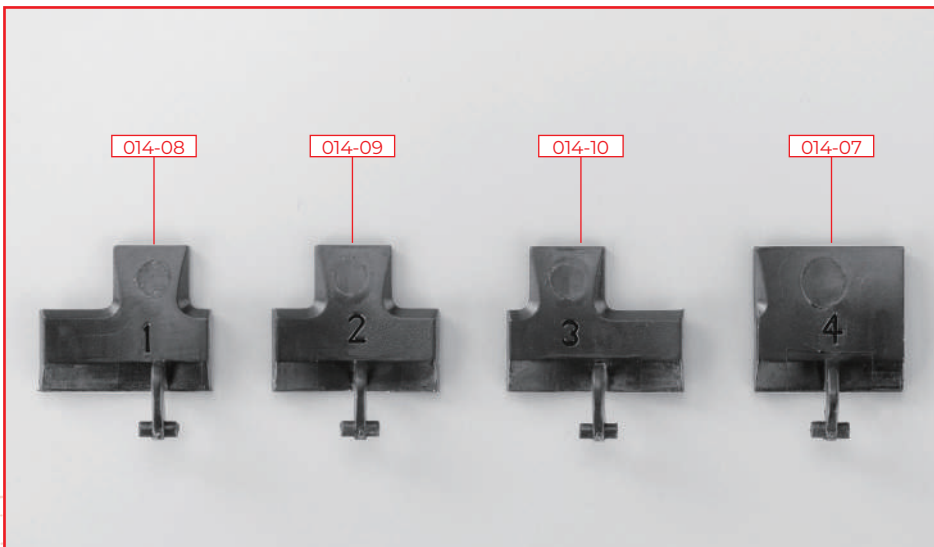

NOTE
 014-08, 014-09, 014-10, 014-07 are marked with the numbers 1, 2, 3, and 4 respectively. The shapes are similar so don't make a mistake.

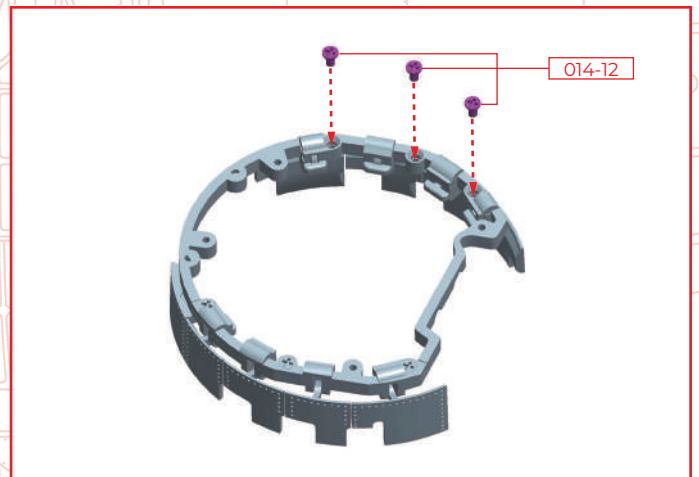
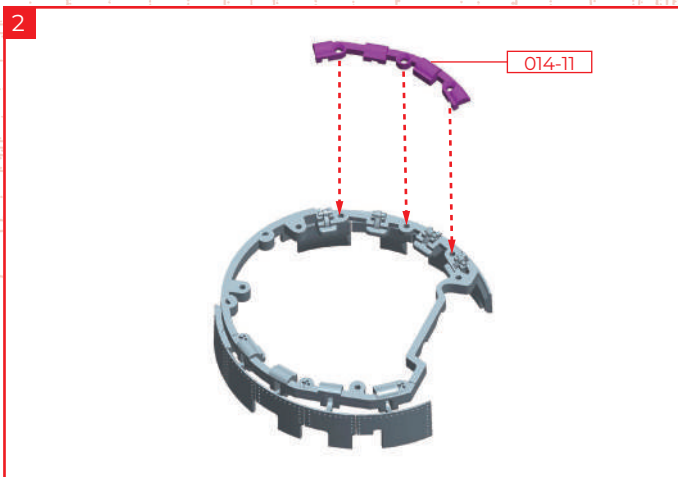

Lower part 014-11 onto the assembly in 1 and fix with 3 x 014-12 screws.

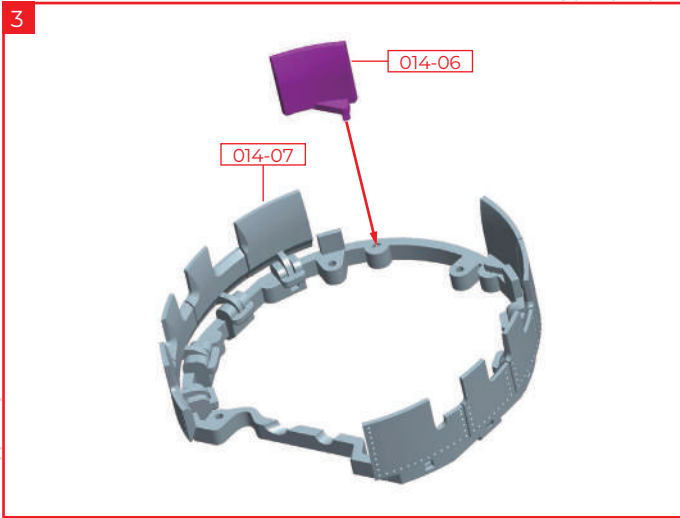

NOTE
014-06 is marked with the number 5.



Turn 2 over and glue 014-06 to the hole on the right of 014-07. This flap doesn't move.

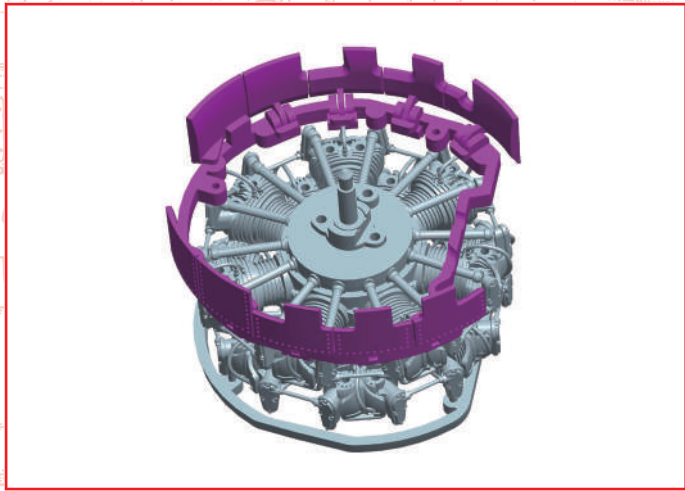
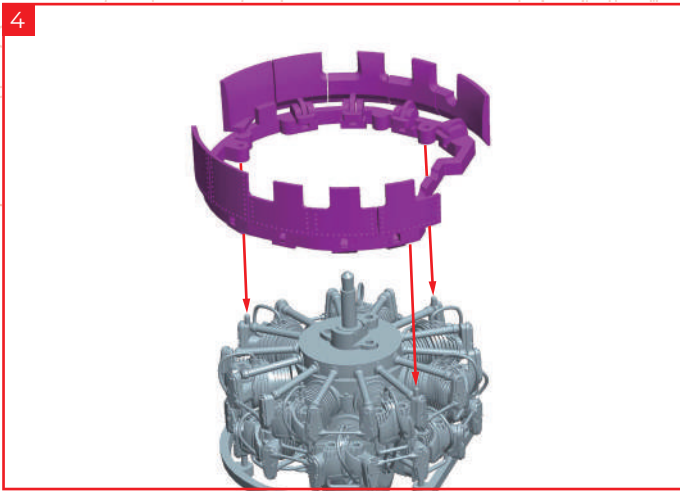

Glue the parts assembled in 3 to the three pegs on the assembly from stage 11. Before gluing, test-fit STEP 2 (next) to see how it goes together.

STEP 2 Mounting the manifold

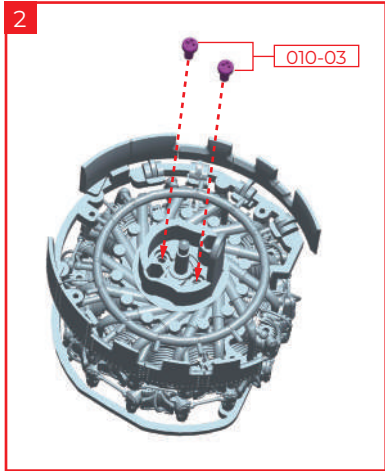
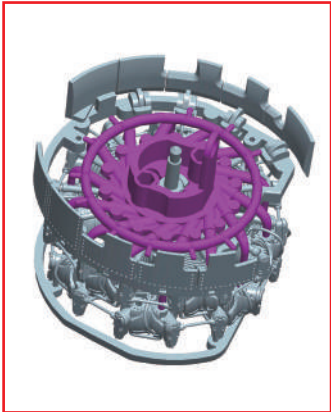
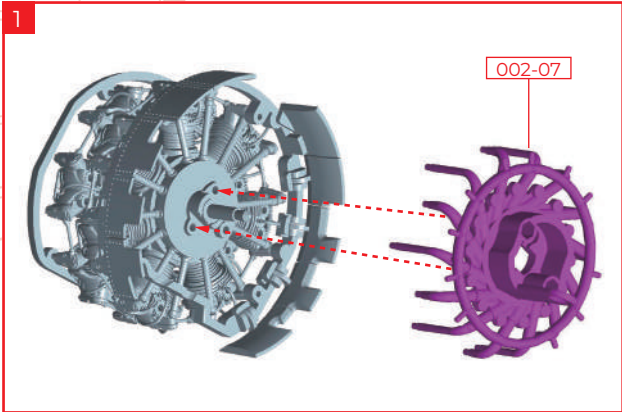

Attach the parts assembled in stage 12 to the engine assembled in STEP 1. There is a big hole and two smaller holes in the centre of part 002-07, but note that the smaller holes are slightly different in size. Each pipe of part 002-07 is inserted into the hole on the cylinder, but if it doesn't fit well, pinch the pipe with tweezers and insert it while guiding it to the hole of the corresponding cylinder.

Fix with 2 x 010-03 that came with stage 10.

STEP 3

Mounting the exhaust pipe, cowling and propeller

← : Glue
 - - - : Don't Glue

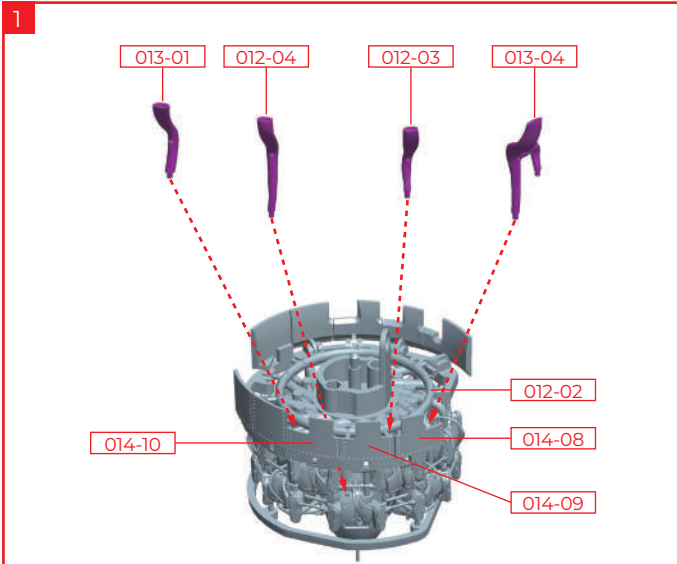

NOTE

If you are struggling to insert the pipes into part 012-02, try shortening 012-02 with a cutter or blade.

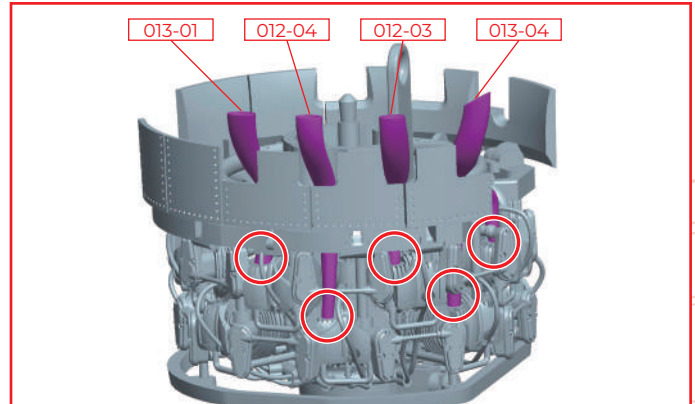

The holes in 013-01, 012-04, 012-03, and 013-04 attach to the engine using the pegs on 012-02. Look carefully at the image to check the mounting position, and insert each pipe through the engine so that the pipes comes out from the notch of the cowl flap installed in STEP 1. **This is demonstrated clearly in our video.**



NOTE

013-01, 012-04, 012-03, 013-04 are engraved with numbers 4, 3, 2, and 1, respectively. The shapes are similar so don't make a mistake.



NOTE

014-5, 014-04, 014-03, 014-0 are marked with 8, 7, 6, and 5, respectively.

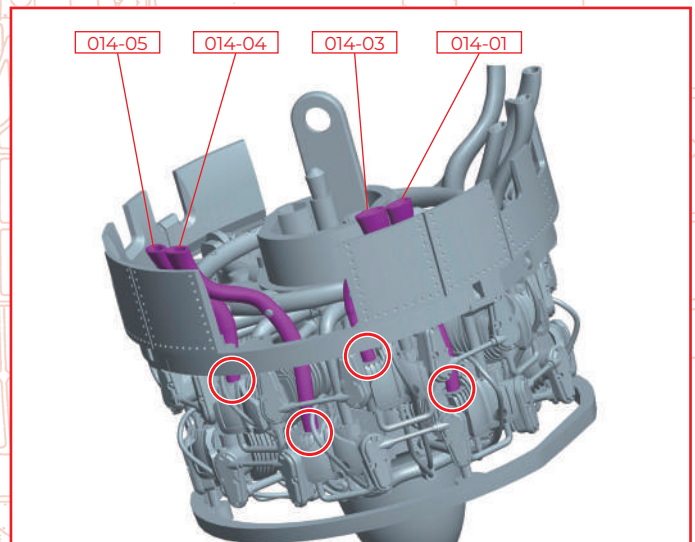
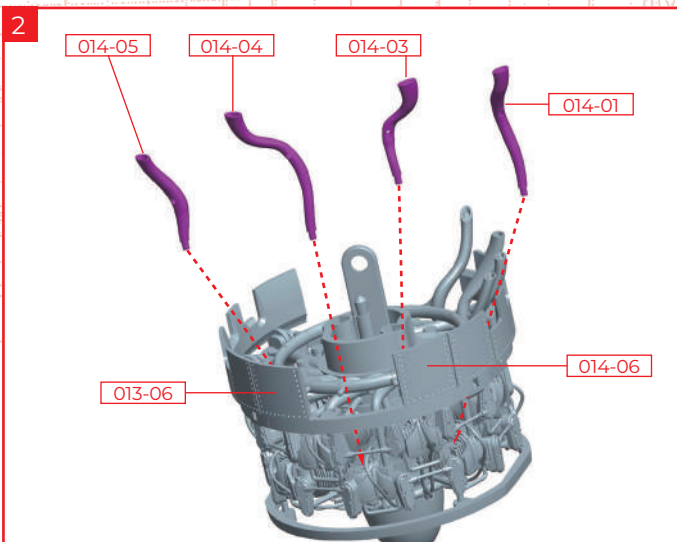

Insert the tip of 014-05, 014-04, 014-03, 014-01 into the engine and push the pegs on 012-02 through the holes. Look closely at the image to confirm the mounting position, and insert each exhaust pipe so that each pipe is along the inside of the cowl flap.

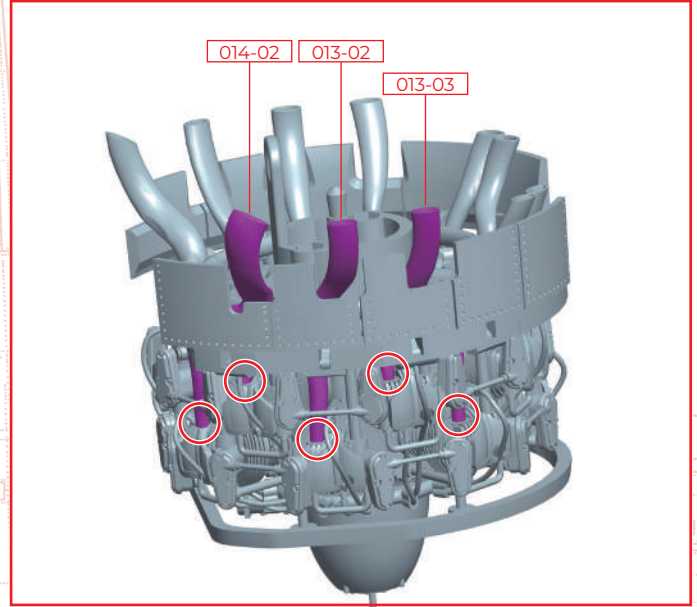
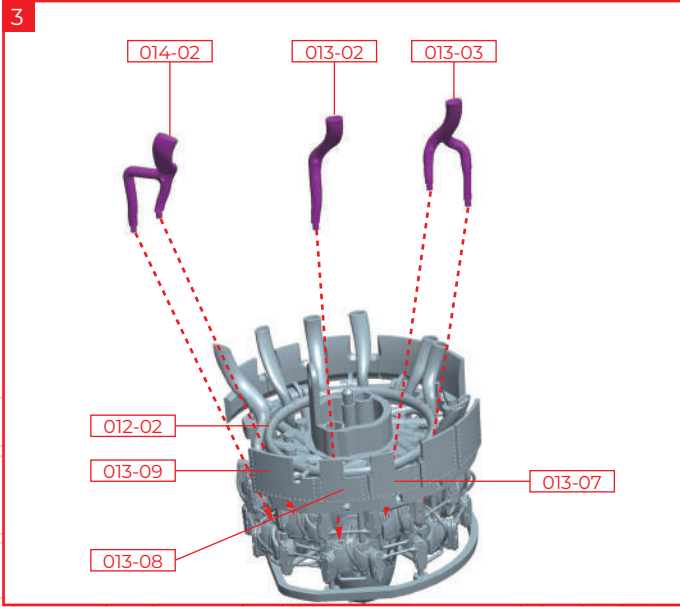

Insert the tip of 014-02, 013-02, 013-03 into the engine and push the pegs on 012-02 through the holes. Look carefully at the image to check the mounting position, and insert each exhaust pipe into the hole so that the pipes come out from the notch of the cowl flap installed in stage 13.

NOTE

014-02, 013-02, 013-03 are marked with C, B, and A, respectively. The shapes are similar so don't make a mistake.

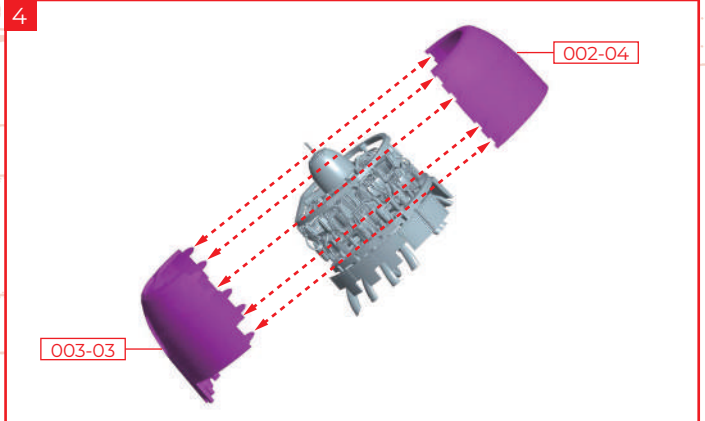

Separate the top and bottom of the cowl assembled in stage 03, insert the engine made in 3, and refit it. Fit 002-04 on the side with the non-moving cowl flaps 013-06 and 014-06. The cowl is attached with a magnet, so do not glue it.

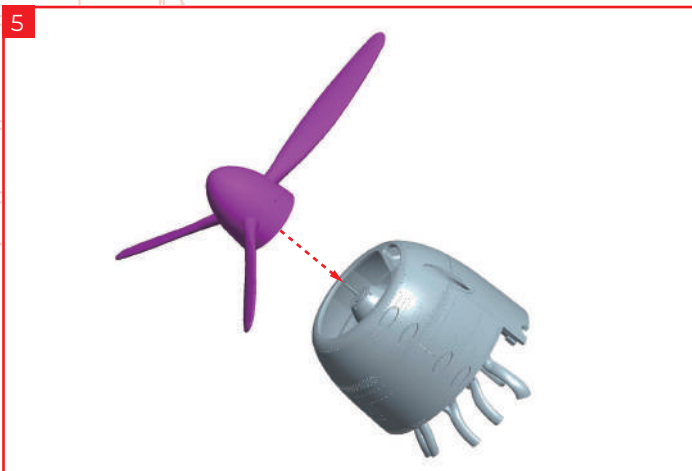

Attach the propeller assembled in stage 01 onto the shaft of the motor attached to the engine. Since the shaft is thin, insert the propeller slowly and securely.



Stage 15: Building the Engine

In this stage we'll assemble the carburettor and mount the connector and supercharger for the propeller motor.

Stage 15 Assembly

The Engine



STAGE 15 PARTS

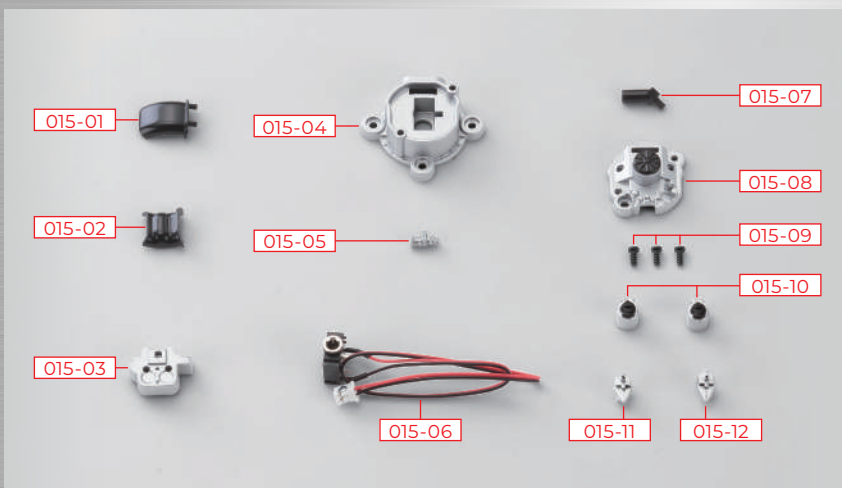

You will also need: superglue, screwdriver, tweezers

PARTS LIST

	PART	No.	MATERIAL
<input type="checkbox"/>	015-01	1	ABS resin
<input type="checkbox"/>	015-02	1	ABS resin
<input type="checkbox"/>	015-03	1	ABS resin
<input type="checkbox"/>	015-04	1	ABS resin
<input type="checkbox"/>	015-05	1	ABS resin
<input type="checkbox"/>	015-06	1	Propeller motor connector
<input type="checkbox"/>	015-07	1	ABS resin
<input type="checkbox"/>	015-08	1	ABS resin
<input type="checkbox"/>	015-09	3 (1 spare)	Steel
<input type="checkbox"/>	015-10	2	ABS resin
<input type="checkbox"/>	015-11	1	ABS resin
<input type="checkbox"/>	015-12	1	ABS resin

STEP 1

Assembling the carburettor

← : Glue
- - - : Don't Glue

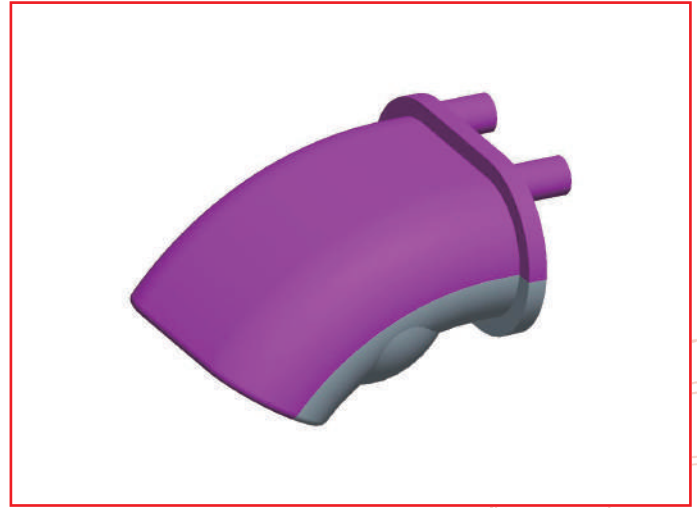
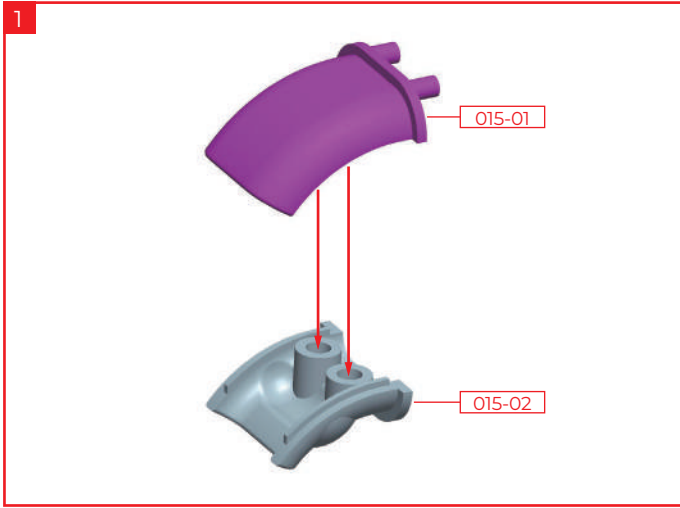

Fit and glue parts for the air intake device 015-01 and 015-02.

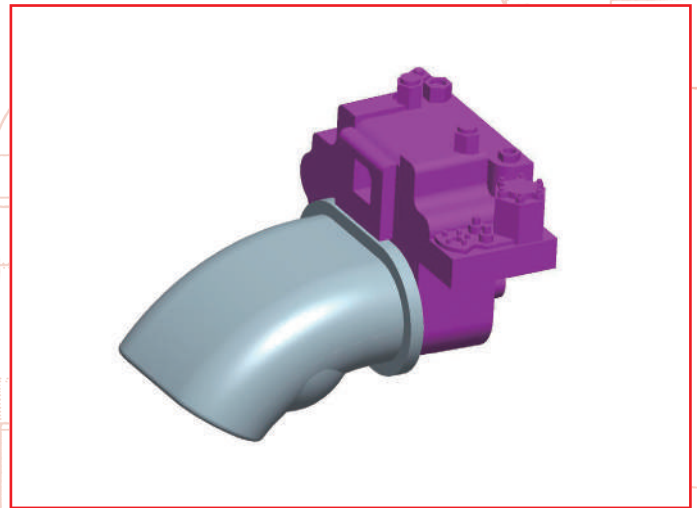
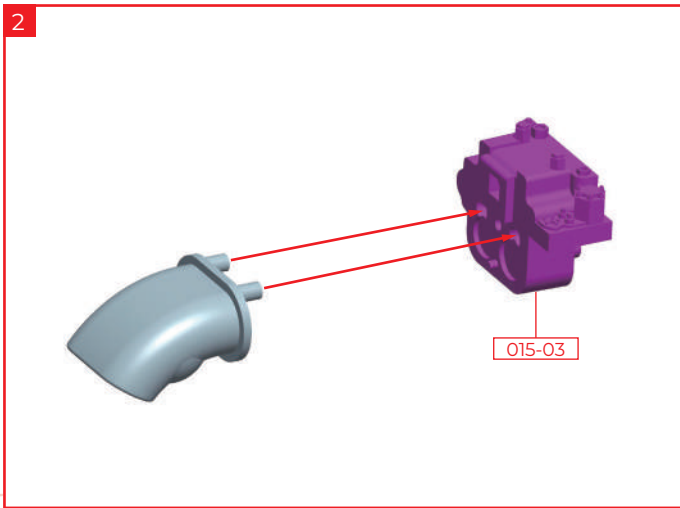

Glue the unit assembled in 1 to the carburettor part 015-03.

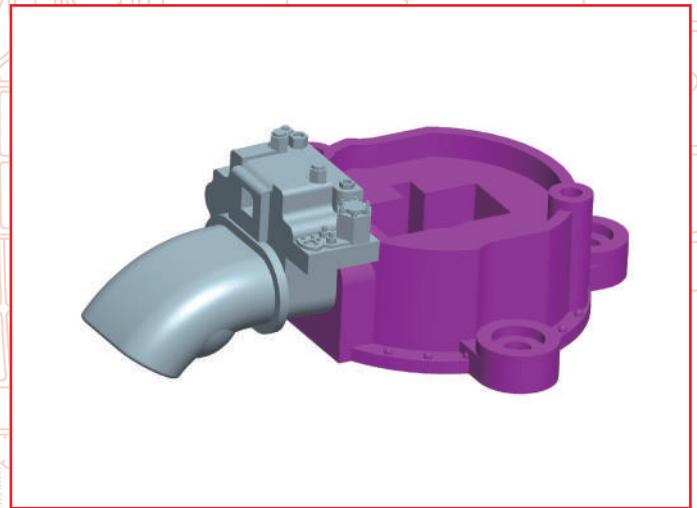
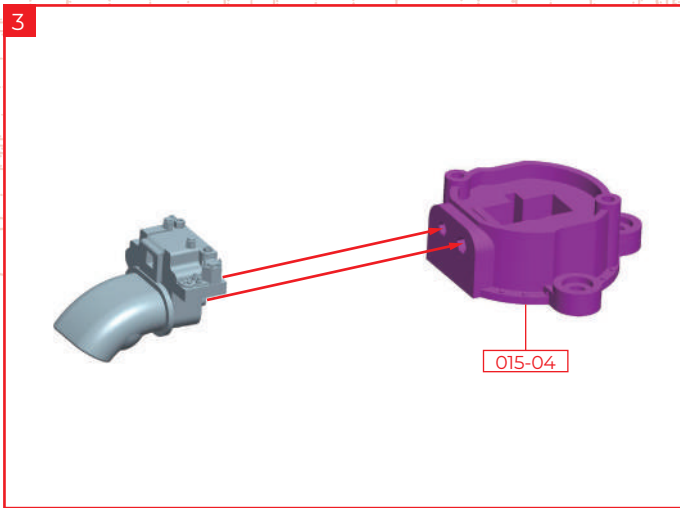

Glue the unit assembled in 2 to the supercharger base part 015-04

4

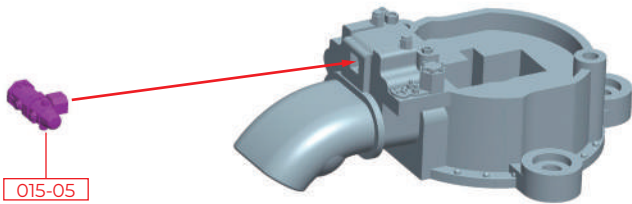

015-05

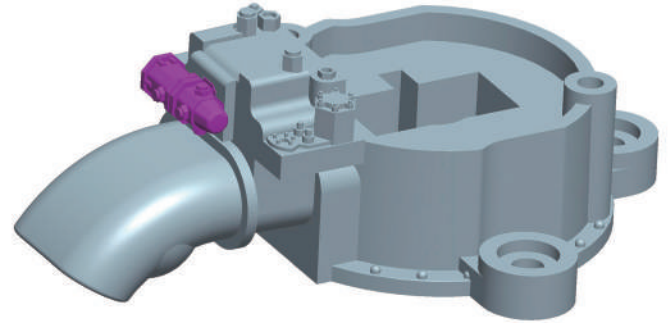

Glue part 015-05 to the unit assembled in 3.

STEP 2

Mounting the connector

1

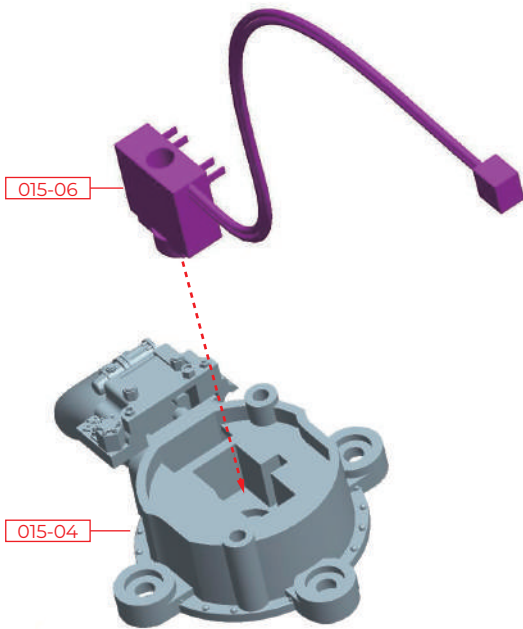

015-06

015-04

Insert the connector 015-06 into the unit assembled in STEP 1. Align the metal protrusion of 015-06 with the notch of 015-04. It's a little stiff, but make sure you push it all the way in.* The shape is slightly different from the 3D drawing, but there is no problem in assembling.

NOTE

Bend the wire of connector 015-06 so that it goes out from the bottom of 015-04. Bend slowly and carefully so that the wire does not break.

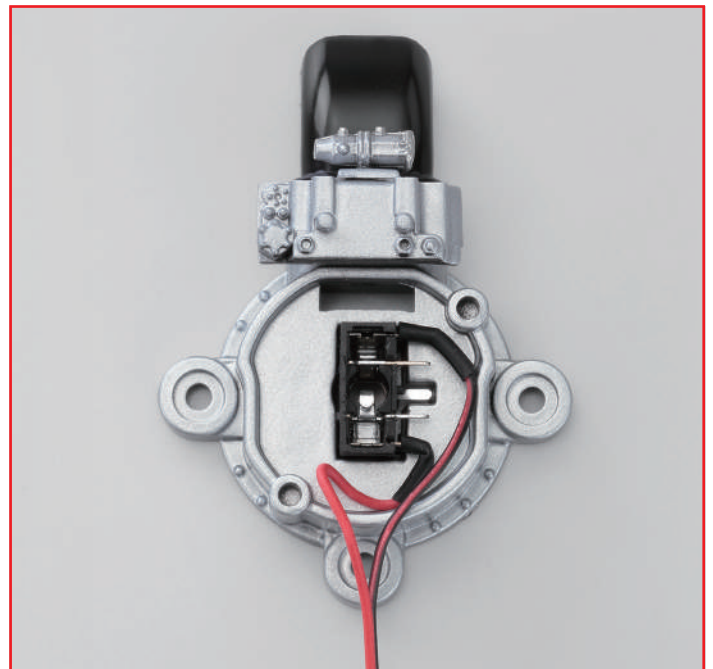

STEP 3

Assembling the supercharger

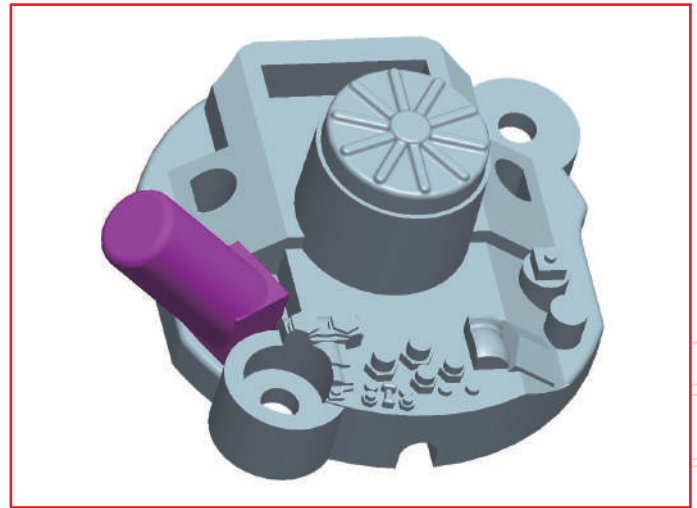
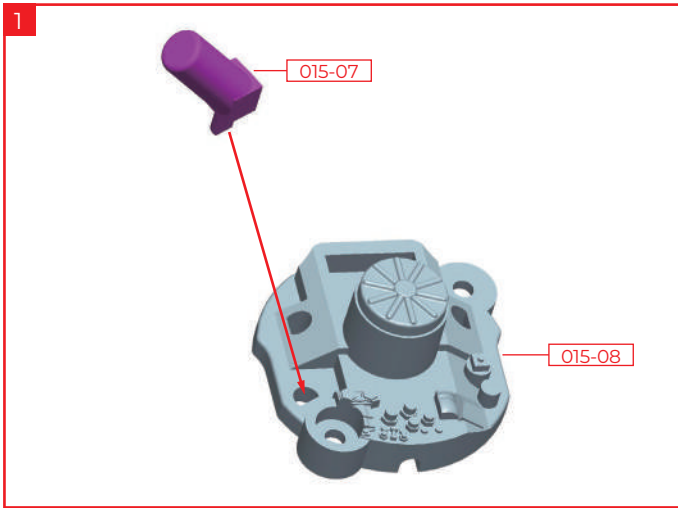

Align the D-shaped pin of 015-07 with the D-shaped hole of part 015-08 and glue it in place.

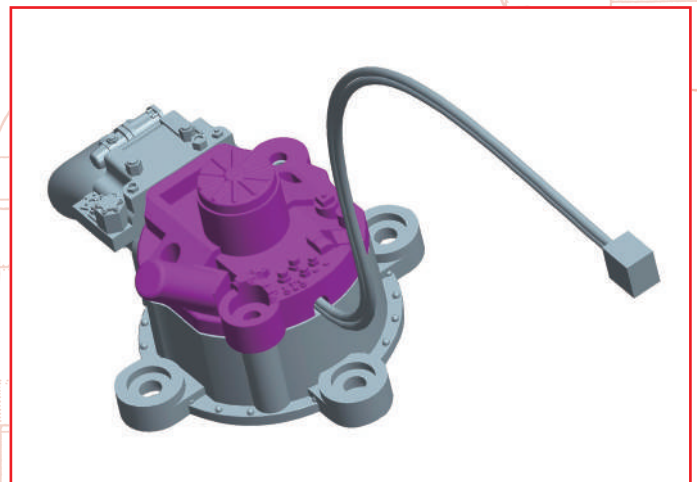
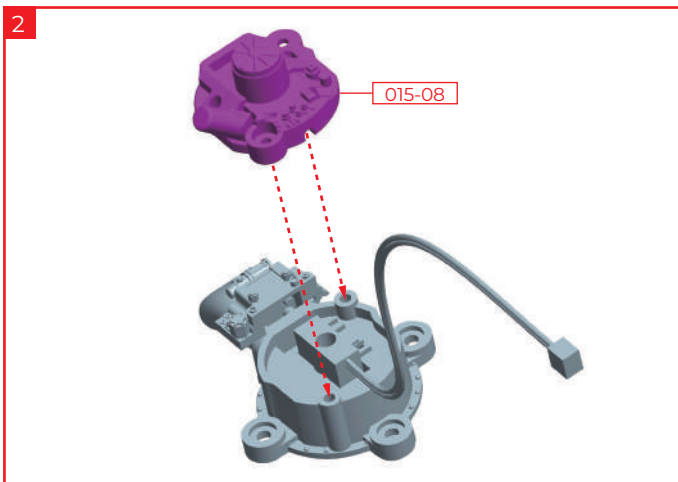

Cover the unit assembled in STEP 2 with the parts assembled in 1. Guide the connector through the notch of 015-08. Be careful not to pinch the wire.

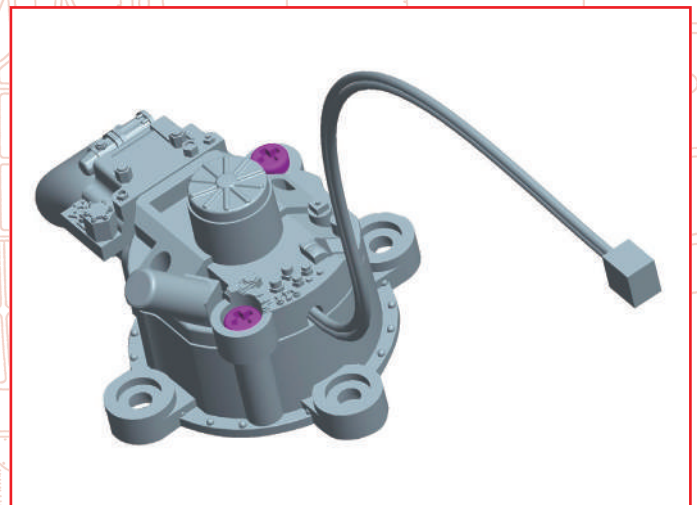
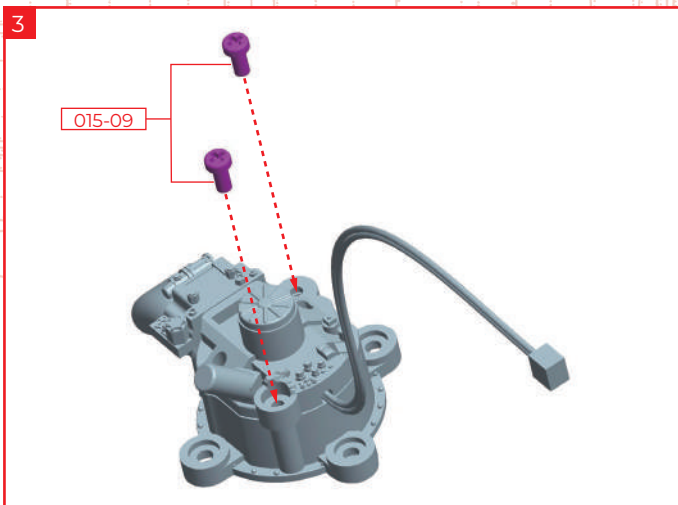

Fix with two 015-09 screws.

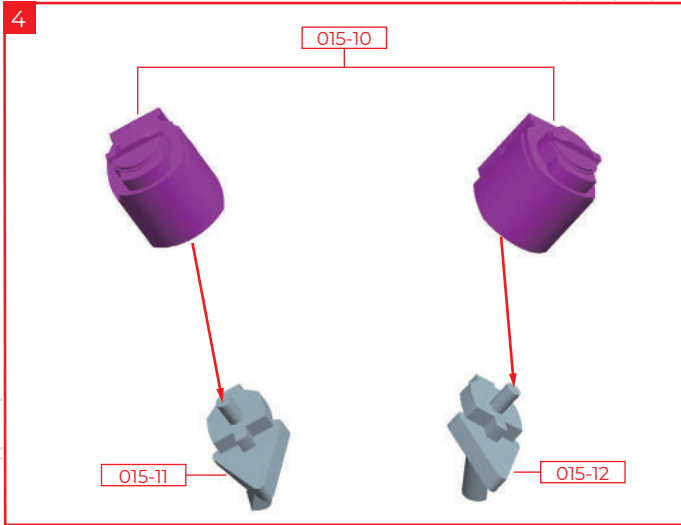

Glue part 015-11 (left) and part 015-12 (right) to the two vacuum pump bases parts 015-10.

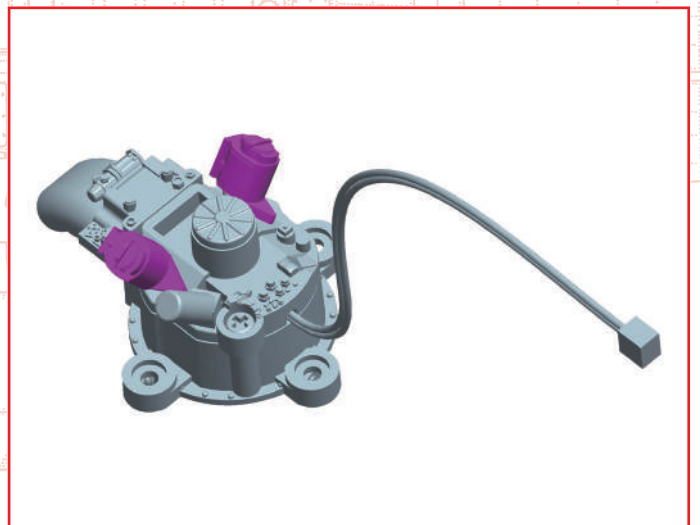
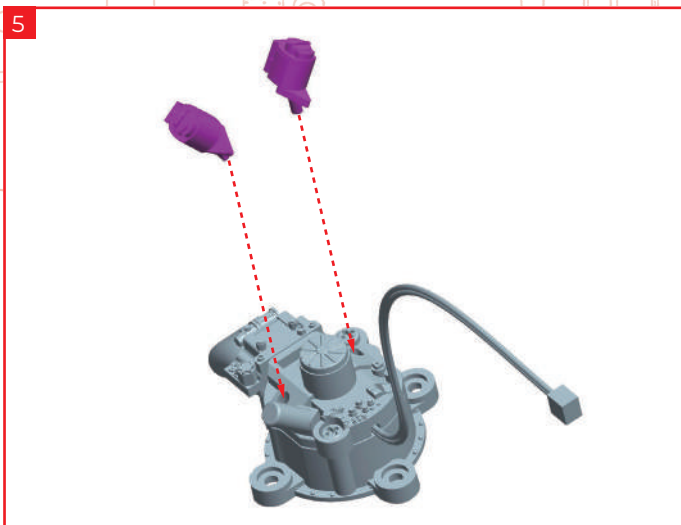

Insert the units assembled in 4 into the unit assembled in 3. Don't glue here. You can now run the propeller motor by attaching the testing battery box 012-01.

STAGE COMPLETE

