

MITSUBISHI A6M ZERO FIGHTER



Pack 07 | Build Instructions

Your 1:18 model of the Japanese Zero is reproduced in the most exquisite detail, with electronics allowing you to recreate aeronautical operations such as take-off and landing, turning, firing and night combat. Lights, machine-gun and propeller sounds bring your legendary fighter plane to life.

In your seventh model pack, you will assemble:

**STAGE 54: TESTING THE RUDDER
SERVOMOTOR**

**STAGE 55: INSTALLING THE GEARBOX FOR
THE TAIL GEAR AND TAIL WHEEL**

**STAGE 56: ATTACHING THE FRAME
COMPONENTS AND THE POWER SUPPLY
CORD**

STAGE 57: INSTALLING THE FLAP MOTOR

**STAGE 58: TESTING AND INSTALLING THE
AILERON SERVOMOTOR**

**STAGE 59: TESTING THE ELEVATOR
SERVOMOTOR AND ELEVATOR (R) ASSEMBLY**

STAGE 60: RUDDER ASSEMBLY

**STAGE 61: ASSEMBLING THE LIMIT SWITCH
AND DISPLAY PEDESTAL**



There are excellent videos showing how to build the Zero [here](#).

Advice from the experts

Spare screws are included with each part. Occasionally, you may be instructed to keep spare or unused screws for a later stage.

Keep these spares in a safe place and label them correctly.

Please make sure you don't mix up the screws. They look quite similar, but the threads do vary slightly. Using the wrong screws may damage the parts.

When securing parts together using multiple screws, fit each screw loosely to ensure all the parts are correctly aligned before gently tightening them firmly, but not overtight, in the order in which you placed them.

The screwdriver can be magnetised by stroking it with a magnet (fridge magnet, etc.) enabling it to hold the screws and make assembly easier.

If a screw is tight going into a metal part, do not force it as you may shear the head off. Remove it and put a tiny smear of Vaseline, soap or light oil on the thread. That will lubricate it and make it easier to drive home.

During the course of this build, you will receive many pieces that you will assemble immediately – following the instructions in the corresponding stage – and other pieces that you should store safely to one side, for use in future assembly stages.

When gluing parts together, glue may be applied to either of the two parts. Some experts find it easier to apply glue to a hole rather than a pin. Choose a method that works best for you.

It's a good idea to test fit your parts so that you can check their positioning before gluing.

Not suitable for children under the age of 14. This product is not a toy and is not designed for use in play. Keep the parts out of the reach of small children. Some parts may have sharp edges. Please handle them with care.

Stage 54: Testing the Rudder Servomotor

In this stage we'll check whether the rudder servomotor is operating properly, so you'll want the battery box and tester at the ready.



Stage 54 Assembly

Rudder Servomotor

STAGE 54 PARTS

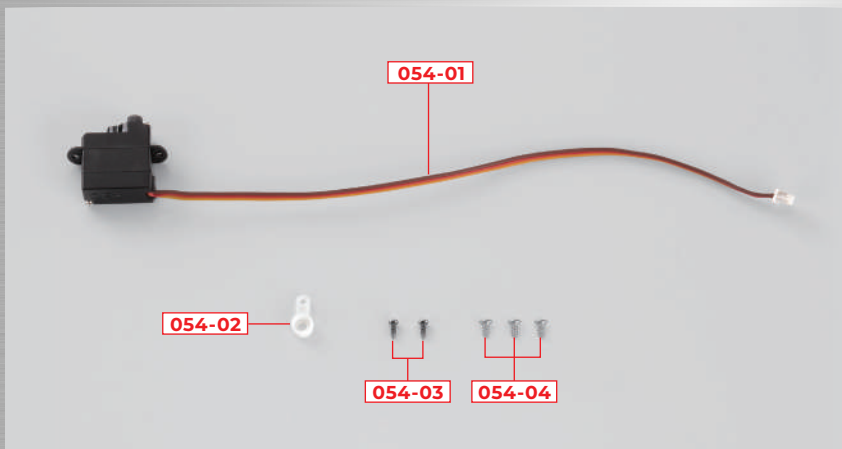

PARTS LIST

	PART	No.	MATERIAL
<input type="checkbox"/>	054-01	1	Servomotor
<input type="checkbox"/>	054-02	1	Plastic
<input type="checkbox"/>	054-03	2	Steel
<input type="checkbox"/>	054-04	3	Steel

You will also need: 3 x AAA batteries

※054-03, 054-04 will be used in a later stage, so keep them in a safe place for now.

STEP 1

Testing the rudder servomotor

← : Glue
 - - - : Don't Glue

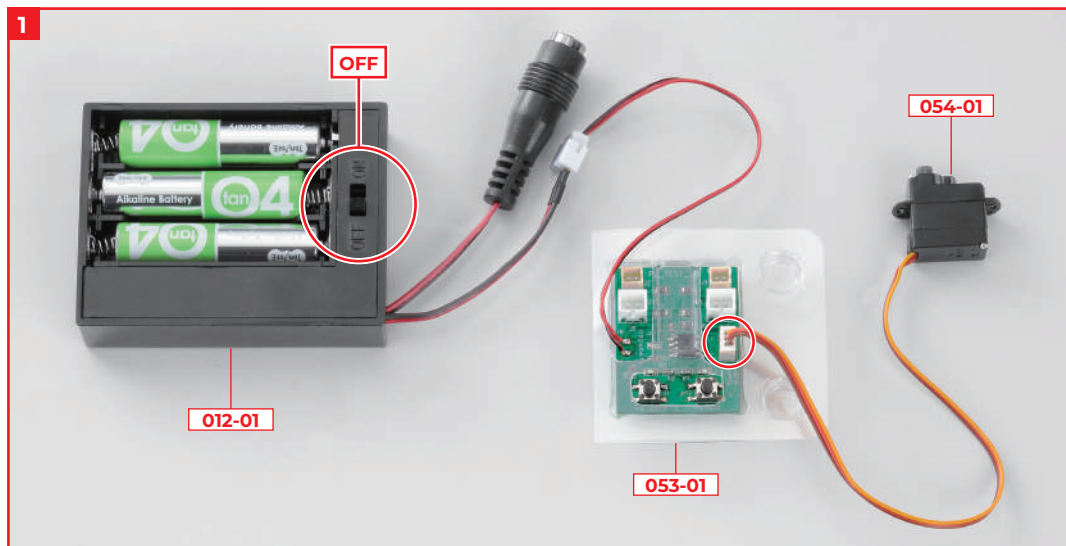

Turn off the power switch on the battery box **012-01** that came with Stage 12, insert three AAA batteries, and connect the power cord connector on the tester **053-01** that came with Stage 53. Insert the connector of the rudder servomotor **054-01** into the servomotor test connector on the tester **053-01**.

NOTE: If the shaft doesn't move after completing the test, please try again using the adaptor **059-12** supplied with stage 59.

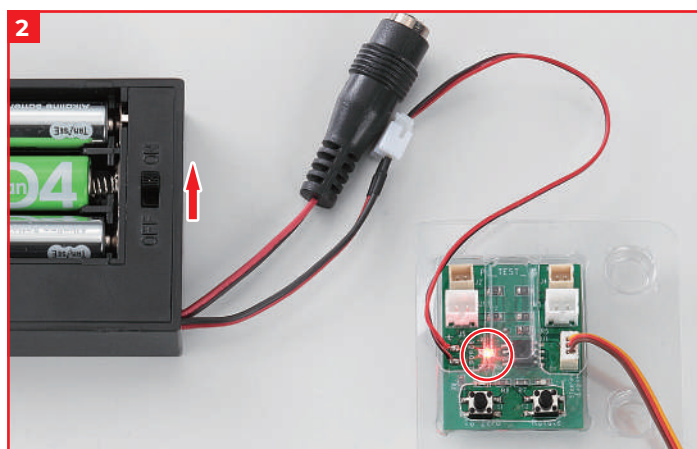

Turn on the power switch on the battery box and check that the power light on the tester **053-01** glows red.

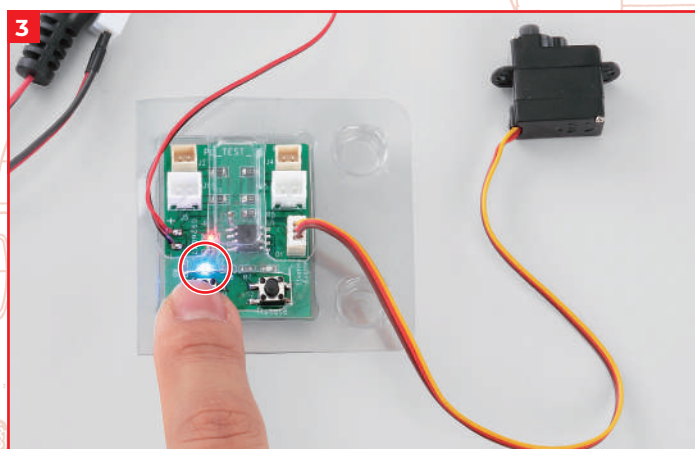

Press the servomotor reset button (left side) of tester **053-01**. The operation light above the button glows blue, and the axis of the rudder servomotor **054-01** is set to the neutral position.



To test the rotation of the rudder servomotor **054-01** shaft, insert the arm **054-02** so that it is easy to see that it is rotating.

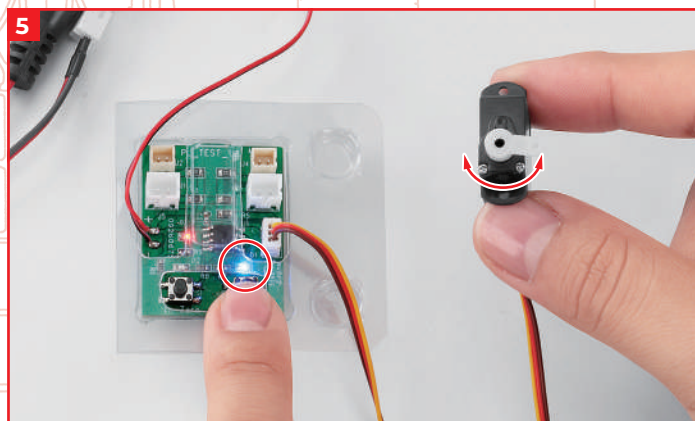

Press the servomotor test button (right side) of tester **053-01**. The operation light on the button glows blue, and the arm **054-02** attached to the shaft moves left and right. When the test is over, remove the arm **054-02**. Arm **054-02** will be used in a later stage, so keep it in a safe place.

Stage 55: Installing the Gearbox for the Tail Gear and Tail Wheel



Stage 55 Assembly

Gearbox for Tail Legs and Wheels

In this stage we'll attach the gearbox for the tail gear and tail wheel to the main fuselage frame. There are a lot of holes on the frame so take extra care when attaching these parts, making sure the right screw is going in the right hole.

STAGE 55 PARTS

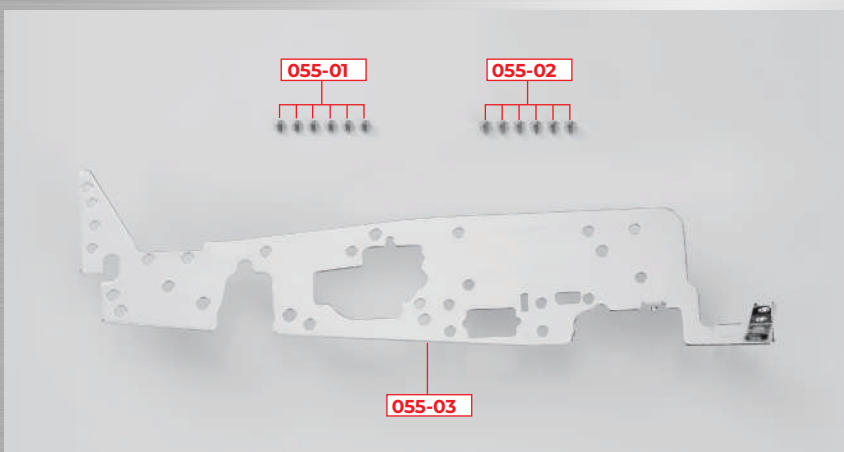

PARTS LIST

	PART	No.	MATERIAL
<input type="checkbox"/>	055-01	6 (1 spare)	Steel
<input type="checkbox"/>	055-02	6 (1 spare)	Steel
<input type="checkbox"/>	055-03	1	Steel

You will also need: screwdriver

※055-01 will be used in a later stage, so keep it in a safe place until then.

STEP 1

Attaching the rear wheel

← : Glue
- - - : Don't Glue

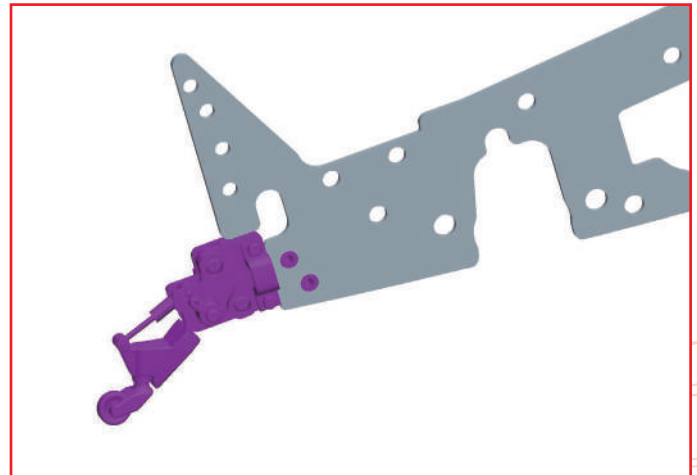
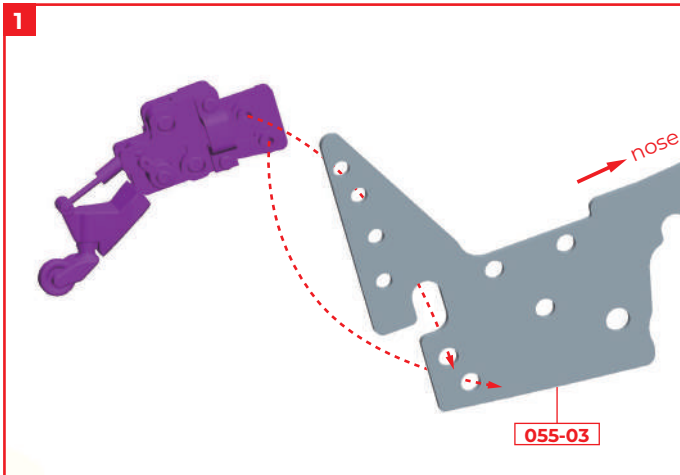

From the left side of the fuselage frame 055-03, fit the two protrusions of the tail gear unit assembled in Stage 53 together.

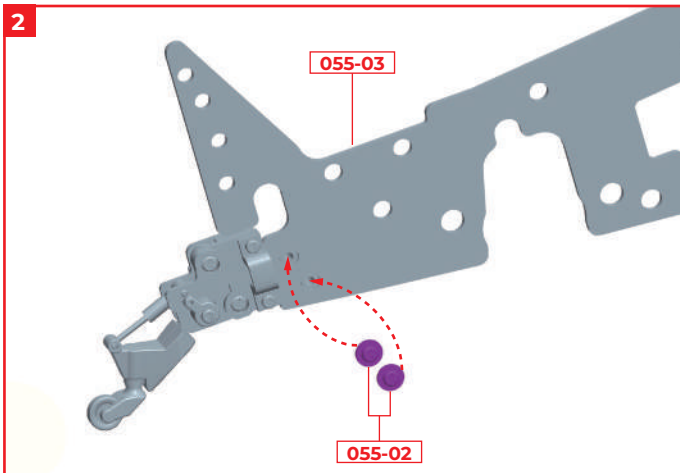

Fix the tail gear unit with 2 x screws 055-02.

NOTE



Note that the two types of screws 055-01 and 055-02 are similar. 055-02 has a sharper threading pitch.

STEP 2

Installing the gearbox for the tail wheel

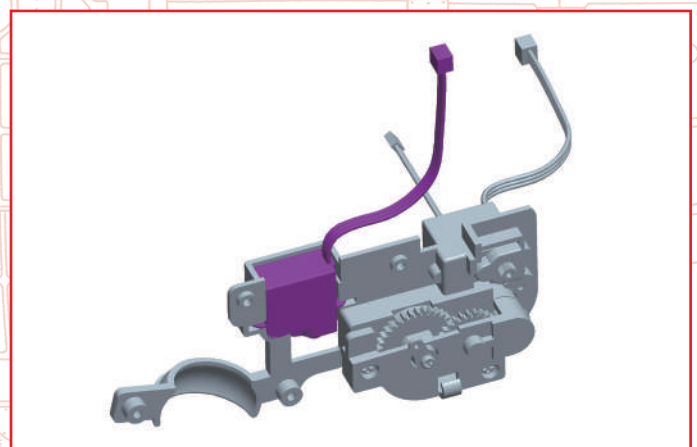
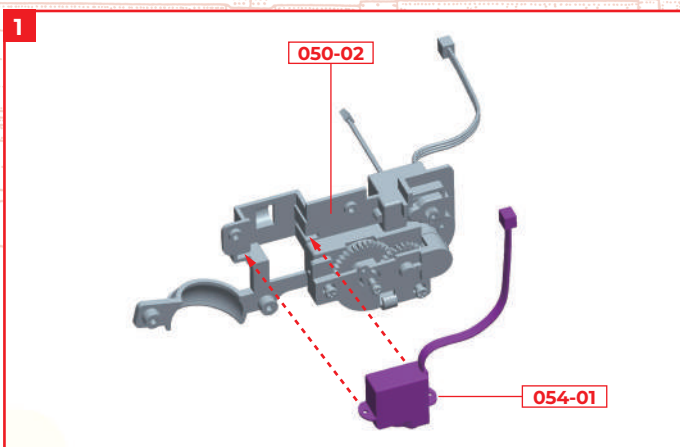

Fit the rudder servomotor 054-01 that came with Stage 54 into the groove of the gearbox assembled in Stage 51. The direction of the servomotor cable should be to the right. Do not glue.

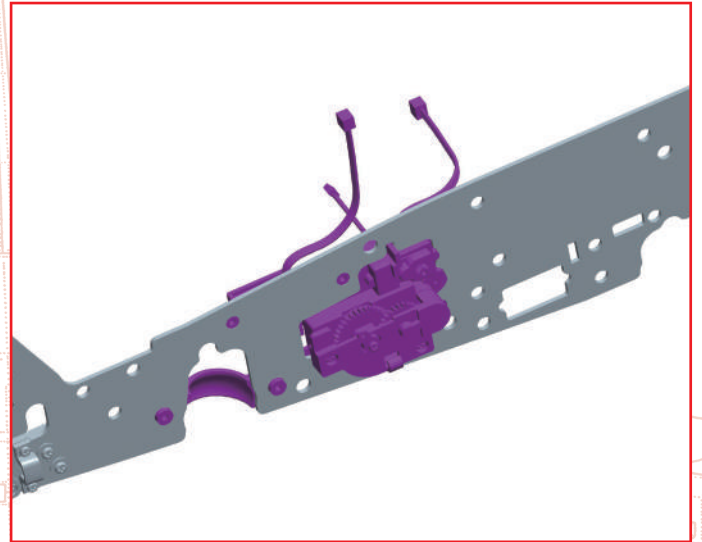
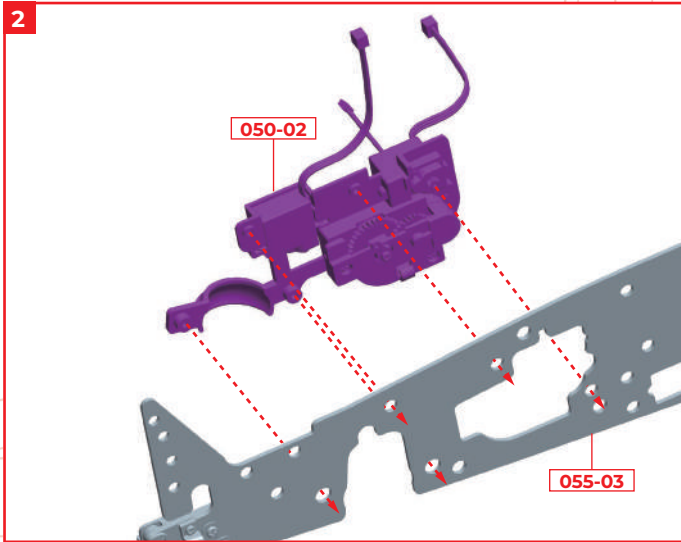

From the left side of the fuselage frame 055-03, align the protrusions of the gearbox with the five holes and fit them together.

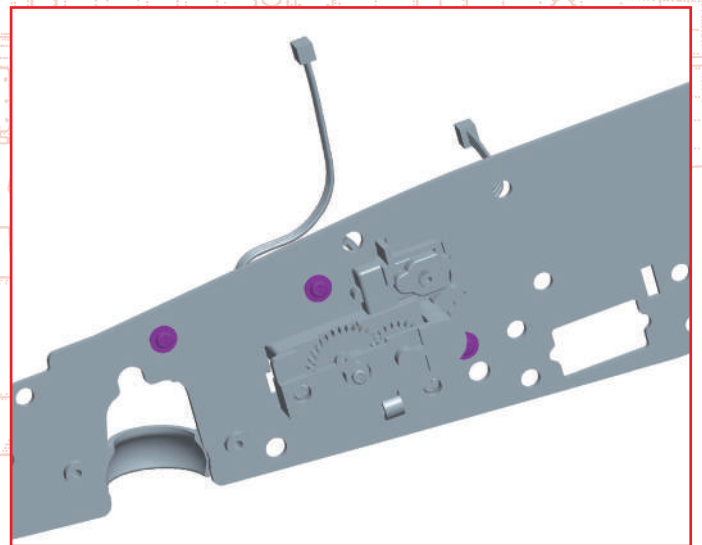
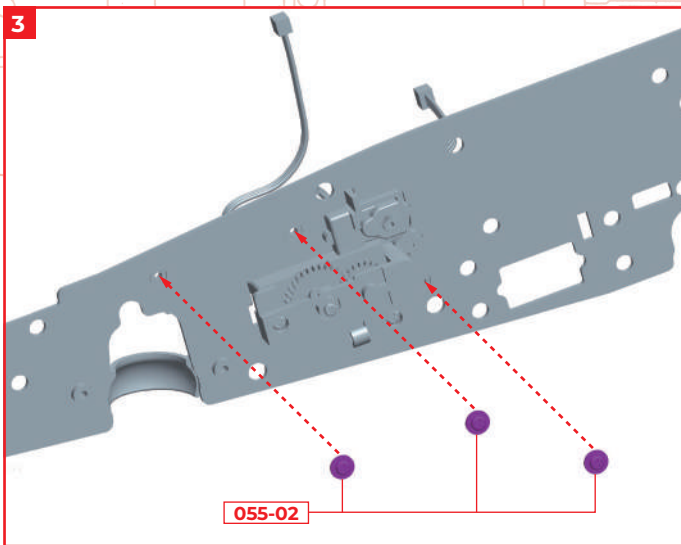

Fix 3 x screws 055-02 in the screw holes at the positions shown.

STAGE COMPLETE

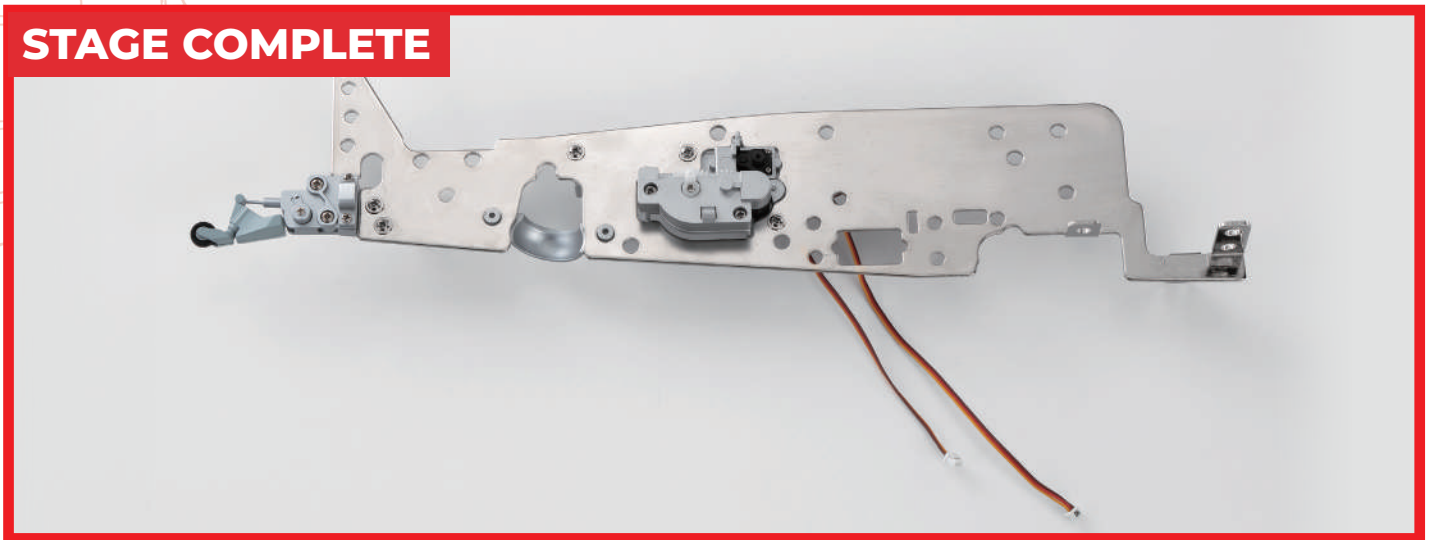

Stage 56: Attaching the Frame Components and the Power Supply Cord



Stage 56 Assembly
 Frame Parts / Power Supply

In this stage we'll attach frame components to the main fuselage frame at three different sites – make sure you place these parts on the correct side (left or right). We'll also be attaching the power supply cord.

STAGE 56 PARTS

PARTS LIST

	PART	No.	MATERIAL
<input type="checkbox"/>	056-01	1	ABS resin
<input type="checkbox"/>	056-02	1	ABS resin
<input type="checkbox"/>	056-03	1	ABS resin
<input type="checkbox"/>	056-04	1	ABS resin
<input type="checkbox"/>	056-05	1	Power supply cord
<input type="checkbox"/>	056-06	3 (1 spare)	Steel
<input type="checkbox"/>	056-07	11 (1 spare)	Steel

You will also need: screwdriver
 ※ The **056-07** screws are divided into **two** bags.

STEP 1

Attaching the frame components

← : Glue
- - - : Don't Glue

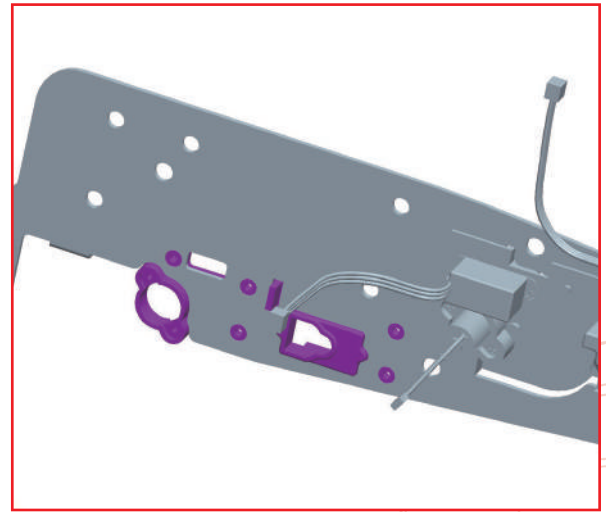
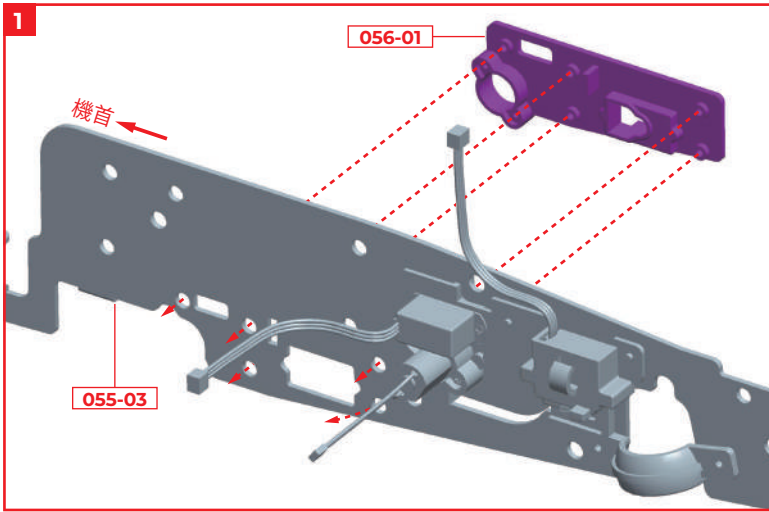

From the right side, align the 5 protrusions of the frame part 056-01 with the 5 holes in the fuselage frame 055-03 assembled in Stage 55 and fit them.

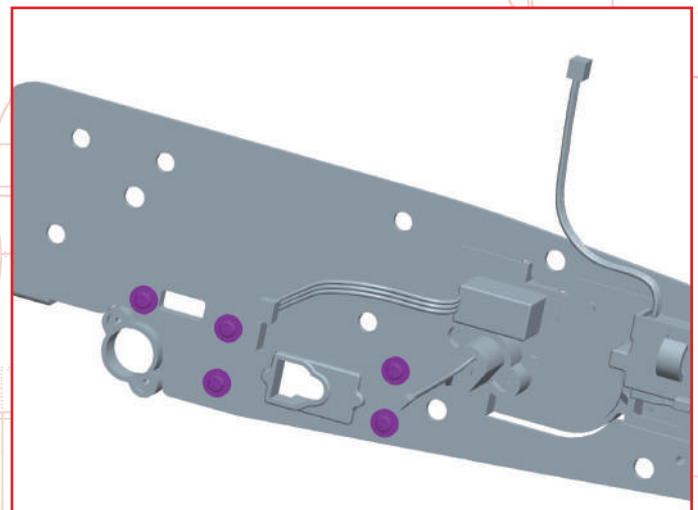
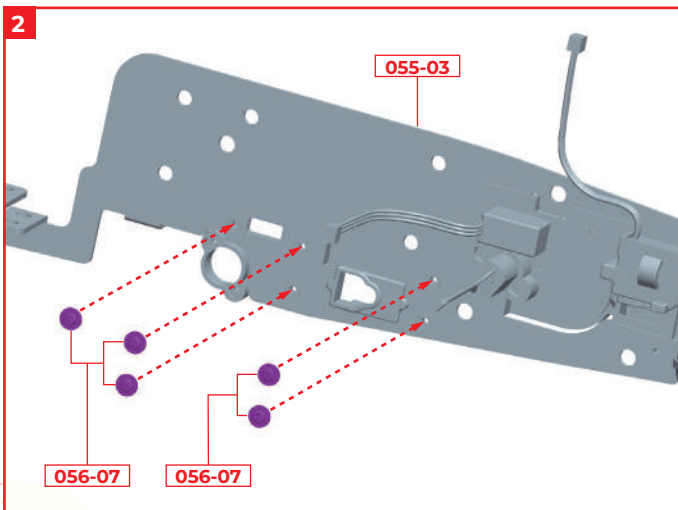

Fix the frame part 056-01 with 5 x screws 056-07.

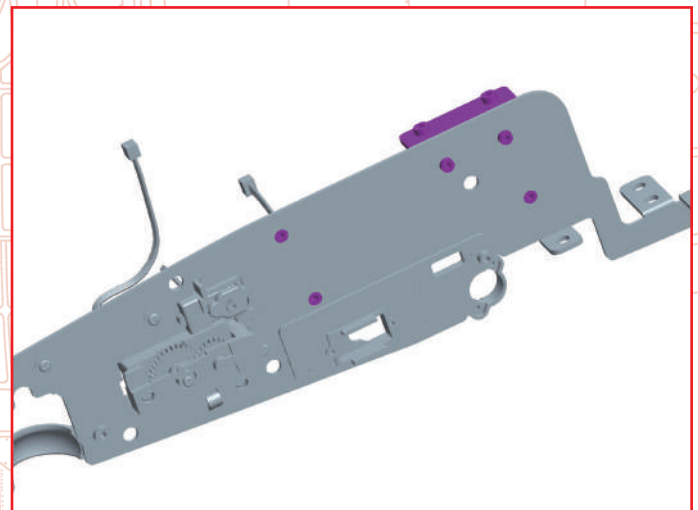
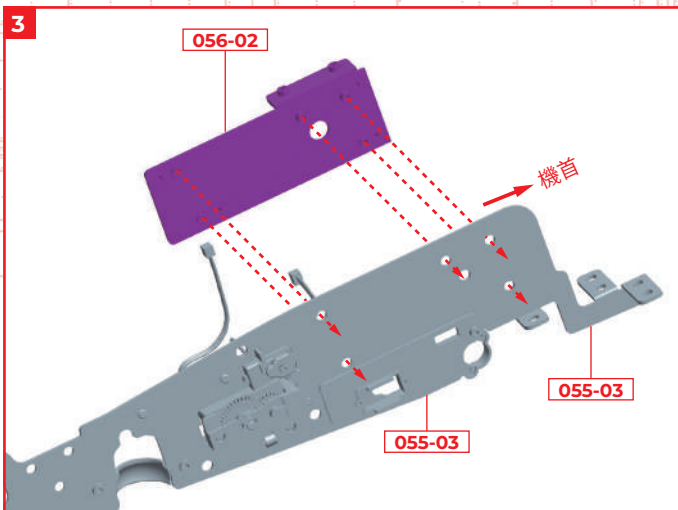

From the left side, align the 5 protrusions of the frame part 056-02 with the 5 holes in the fuselage frame 055-03 and fit them together.

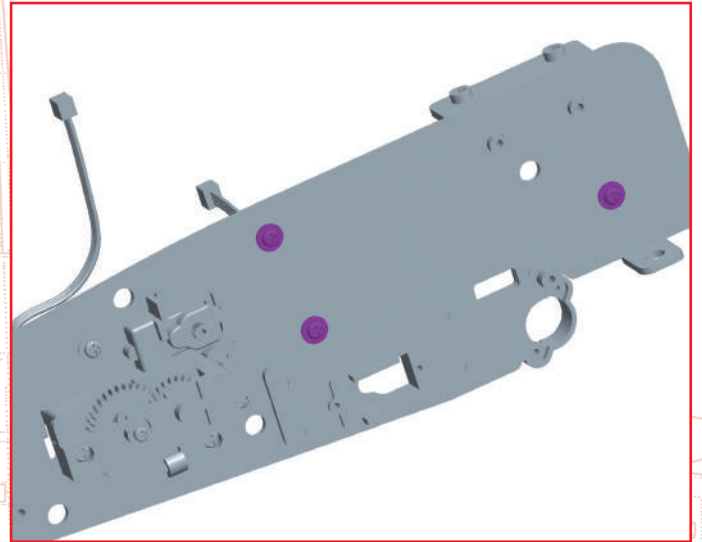
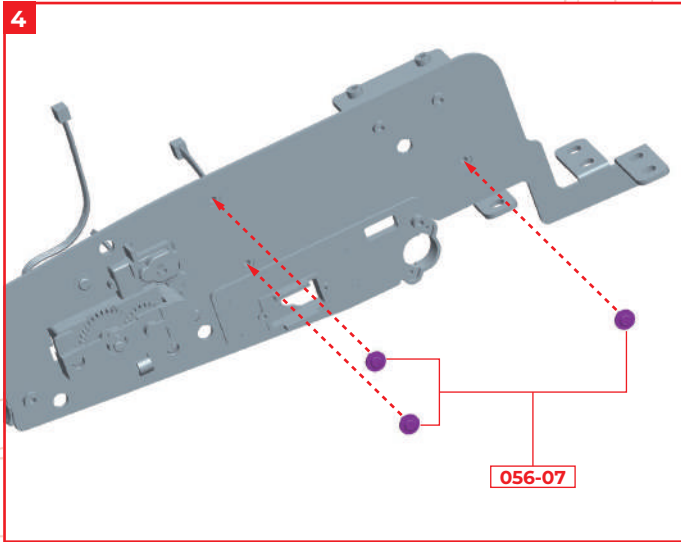

Fix the frame part 056-02 with 3 x screws 056-07.

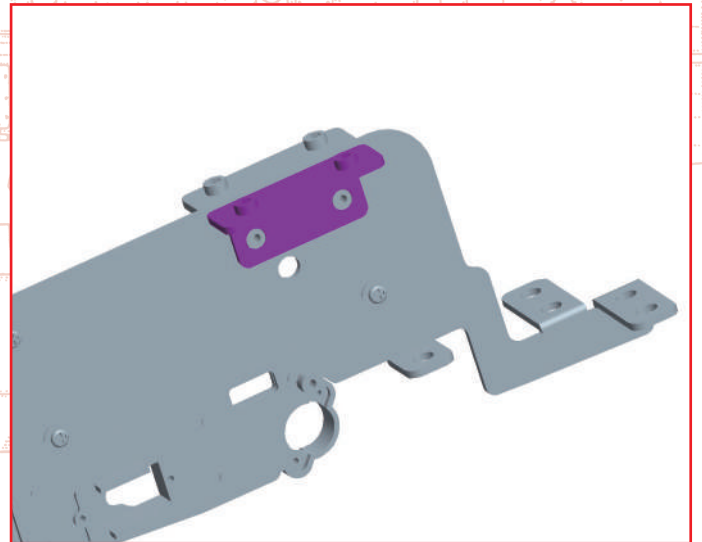
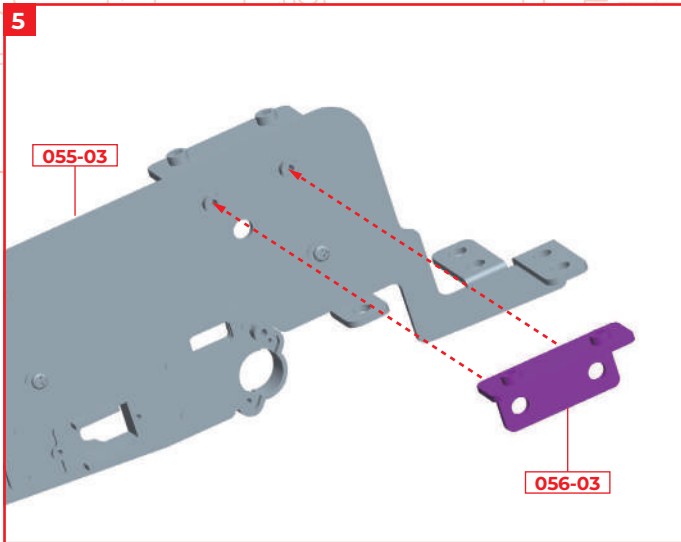

From the right side of the fuselage frame 055-03, align the two holes in the frame part 056-03 and fit them.

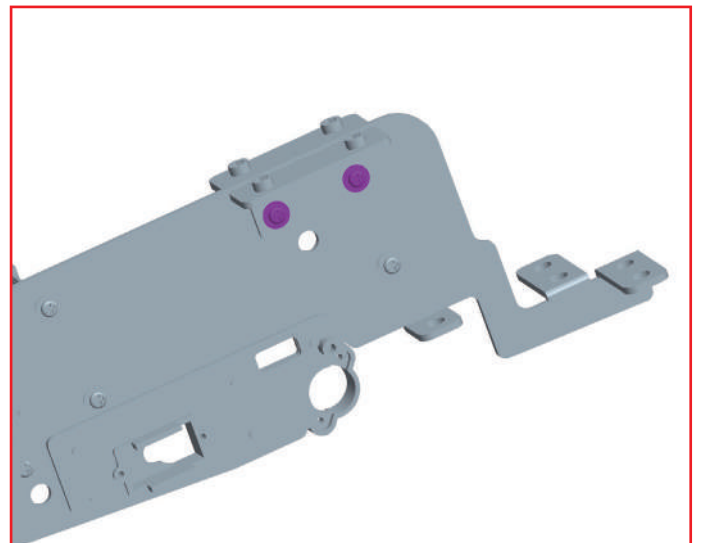
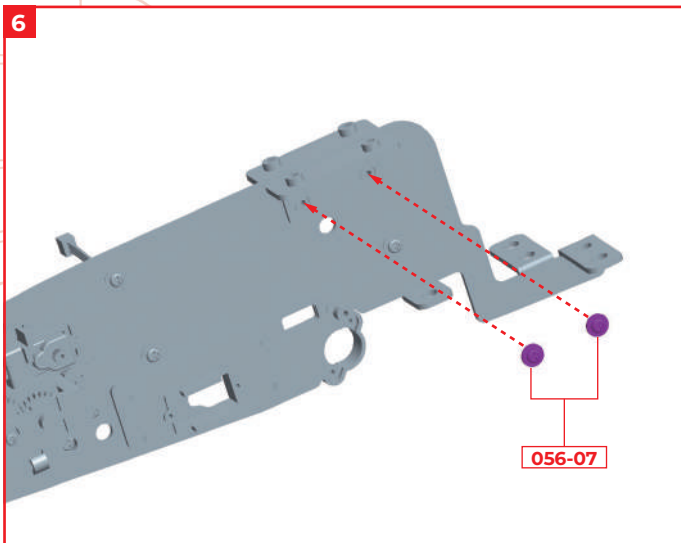

Fix the frame part 056-03 with 2 x screws 056-07.

STEP 2

Attaching the power supply cord

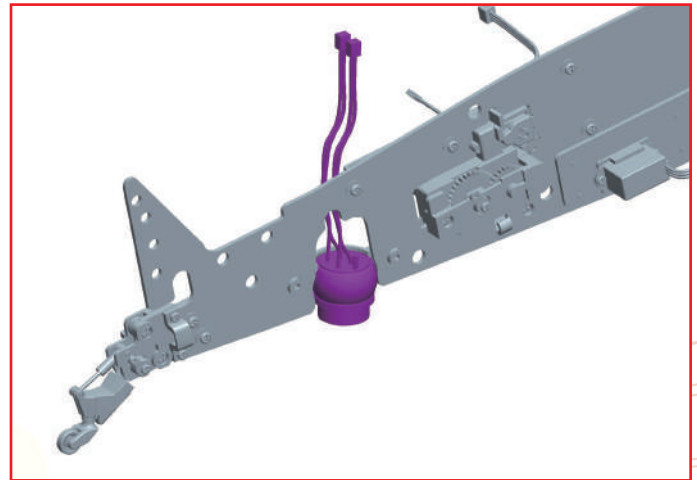
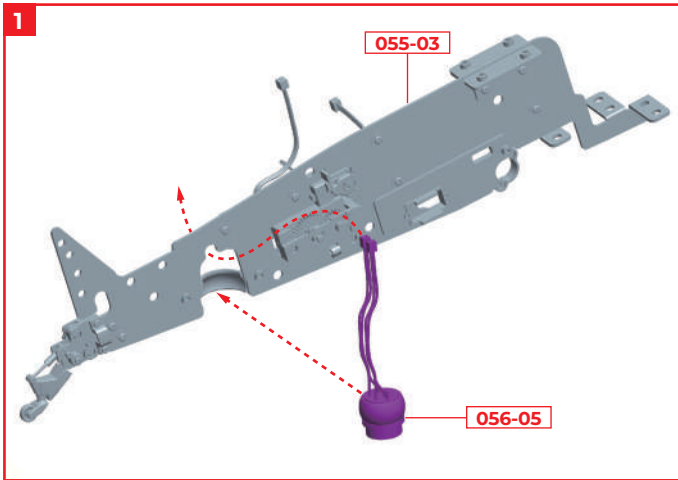

Fit the power supply cord 056-05 into the gearbox attached to the fuselage frame 055-03 in Stage 55. The two cords on the power supply cord 056-05 are pulled out to the left through the hole between the fuselage frame 055-03 and the gearbox.

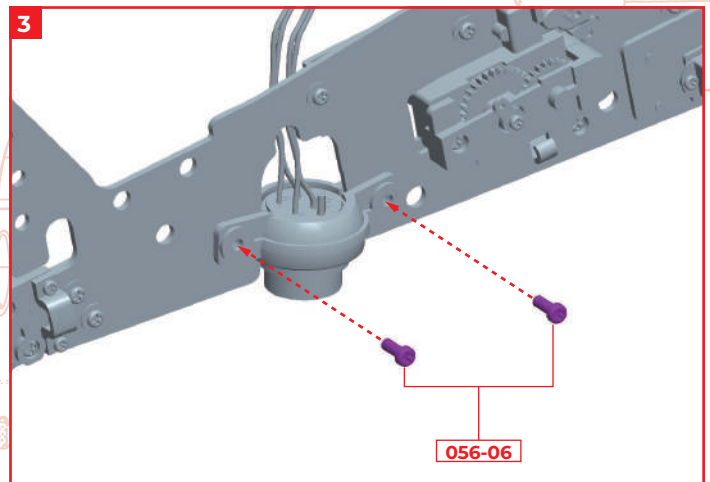
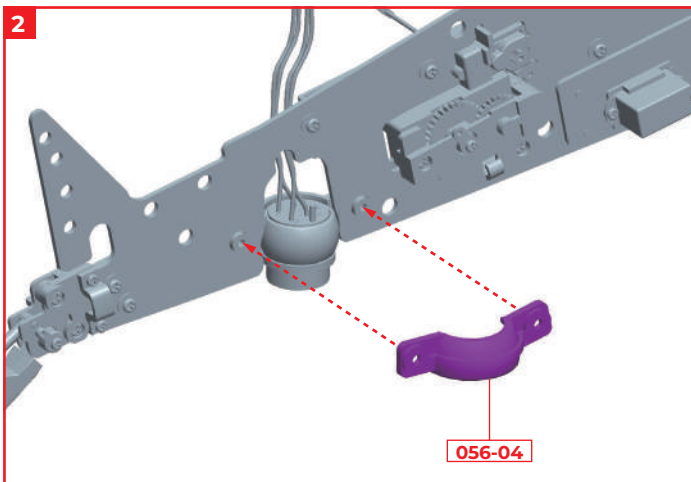

Fit the power supply cord cover 056-04.

Secure the cover 056-04 with 2 x screws 056-06. After completion, the aircraft will swing up, down, left and right, so there is some play in the attached power supply cord.

STAGE COMPLETE

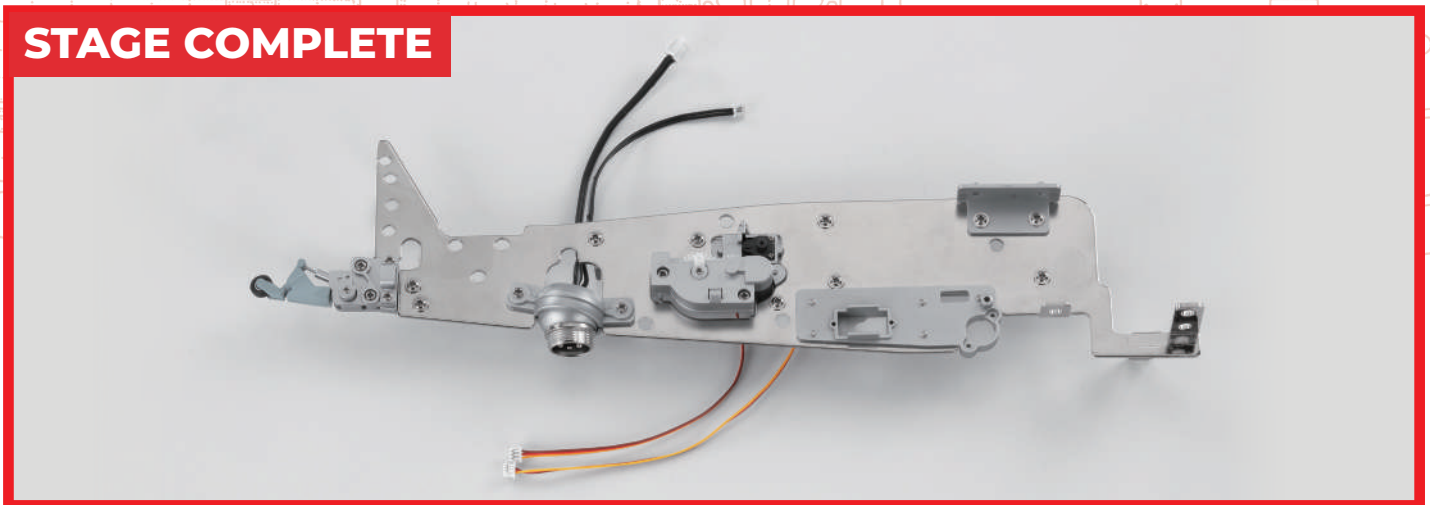

Stage 57: Installing the Flap Motor

In this stage we'll install the motor which powers the wing flaps in the main frame.

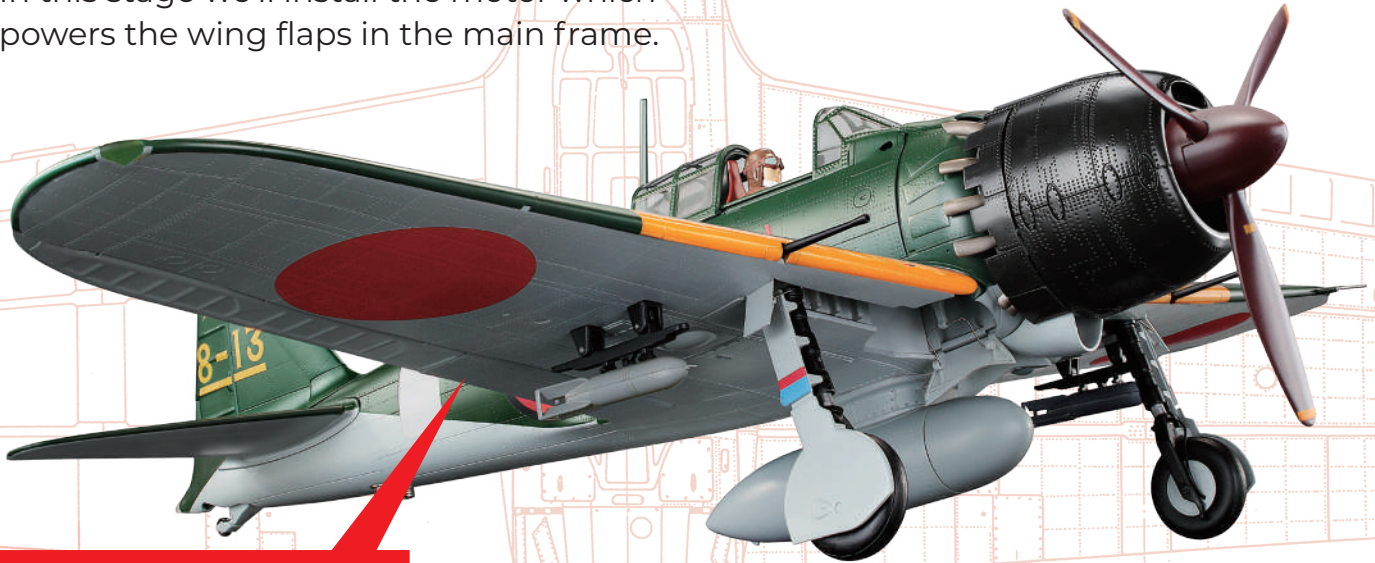

Stage 57 Assembly

Flap Motor

STAGE 57 PARTS

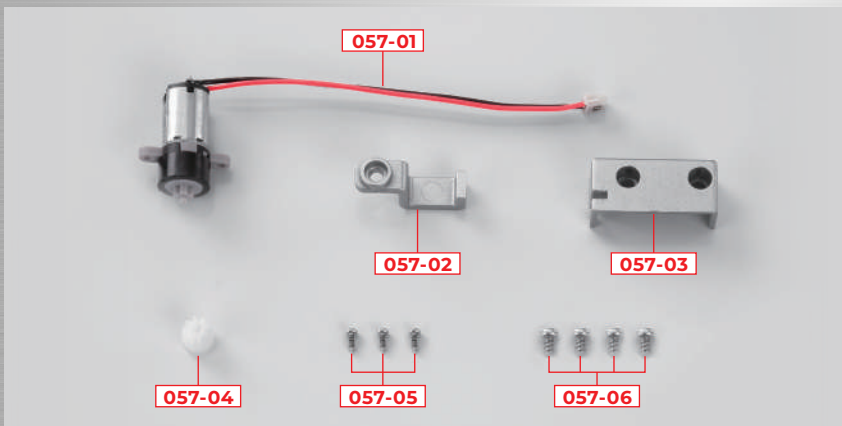

You will also need: screwdriver
 ※057-02, 057-03, 057-06 will be used in later stages, so keep them in a safe place for now.

PARTS LIST

	PART	No.	MATERIAL
<input type="checkbox"/>	057-01	1	Motor
<input type="checkbox"/>	057-02	1	ABS resin
<input type="checkbox"/>	057-03	1	ABS resin
<input type="checkbox"/>	057-04	1	Plastic
<input type="checkbox"/>	057-05	3 (1 spare)	Steel
<input type="checkbox"/>	057-06	4 (1 spare)	Steel

STEP 1

Installing the flap motor

← : Glue
← : Don't Glue

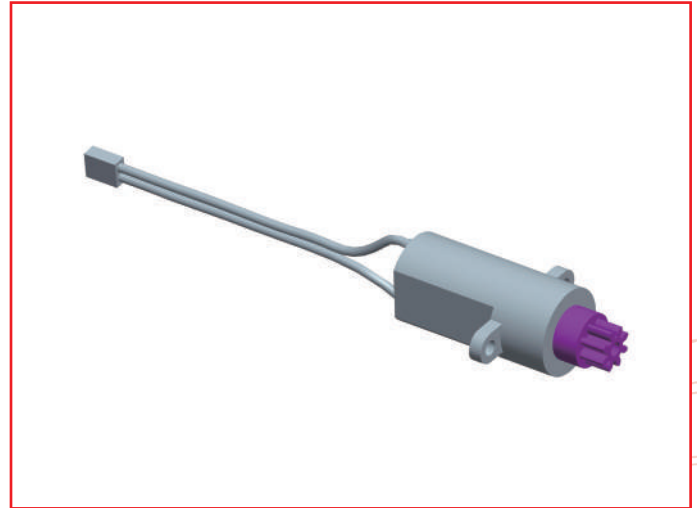
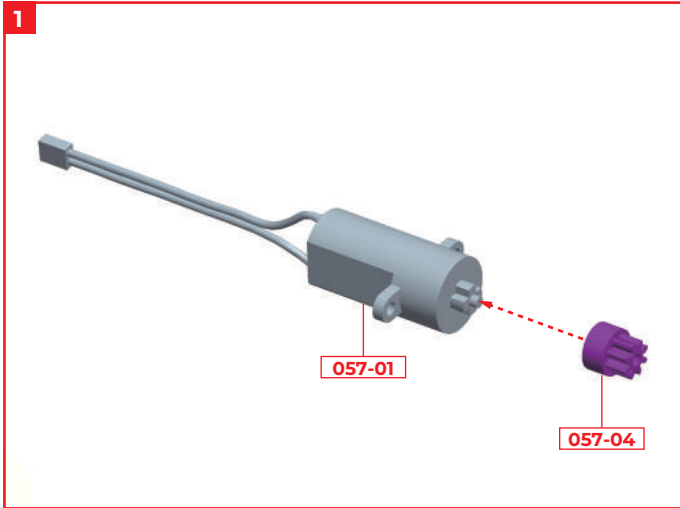

Insert gear 057-04 into the flap motor 057-01.

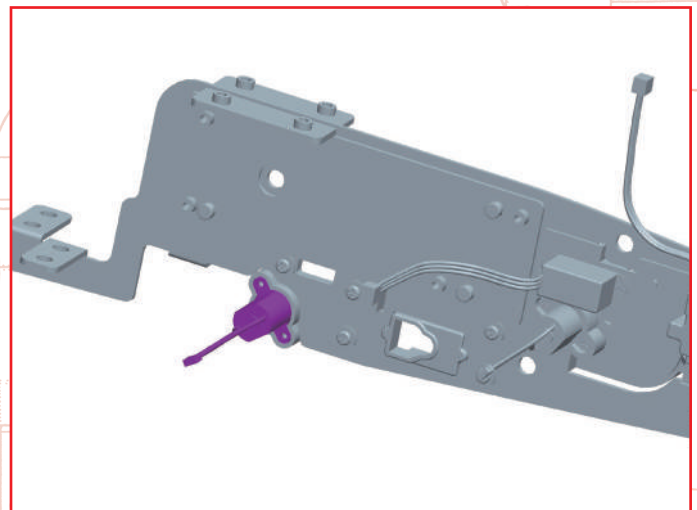
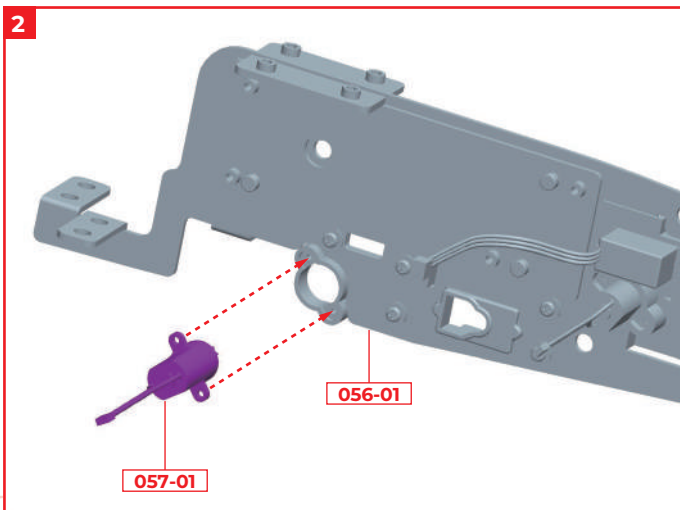

Fit the flap motor 057-01 into the frame part 056-01 attached to the fuselage frame 055-03 in Stage 56.

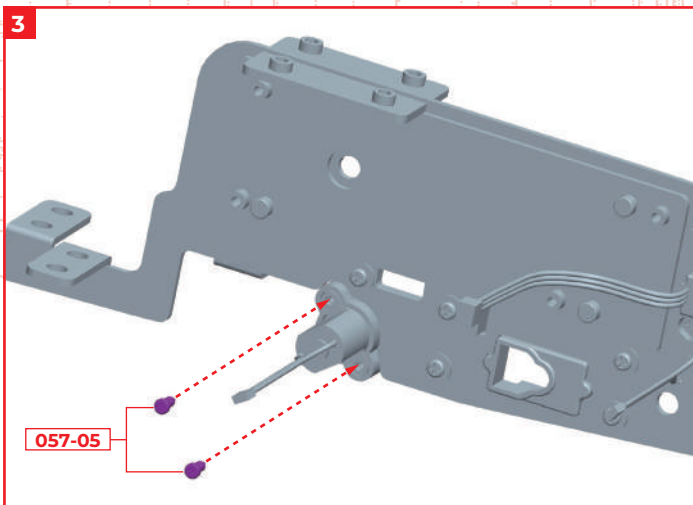

Fix the flap motor 057-01 with 2 x screws 057-05.

STAGE COMPLETE

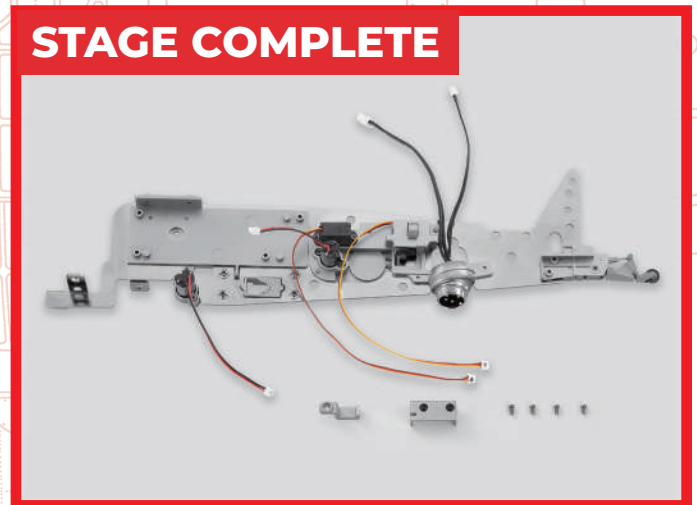

Stage 58: Testing and Installing the Aileron Servomotor

In this stage we'll test the servomotor used to power the ailerons to ensure it is working properly, so we'll need the battery box from stage 12 and the tester from stage 53. After making sure everything is in order we'll mount it to the main frame.

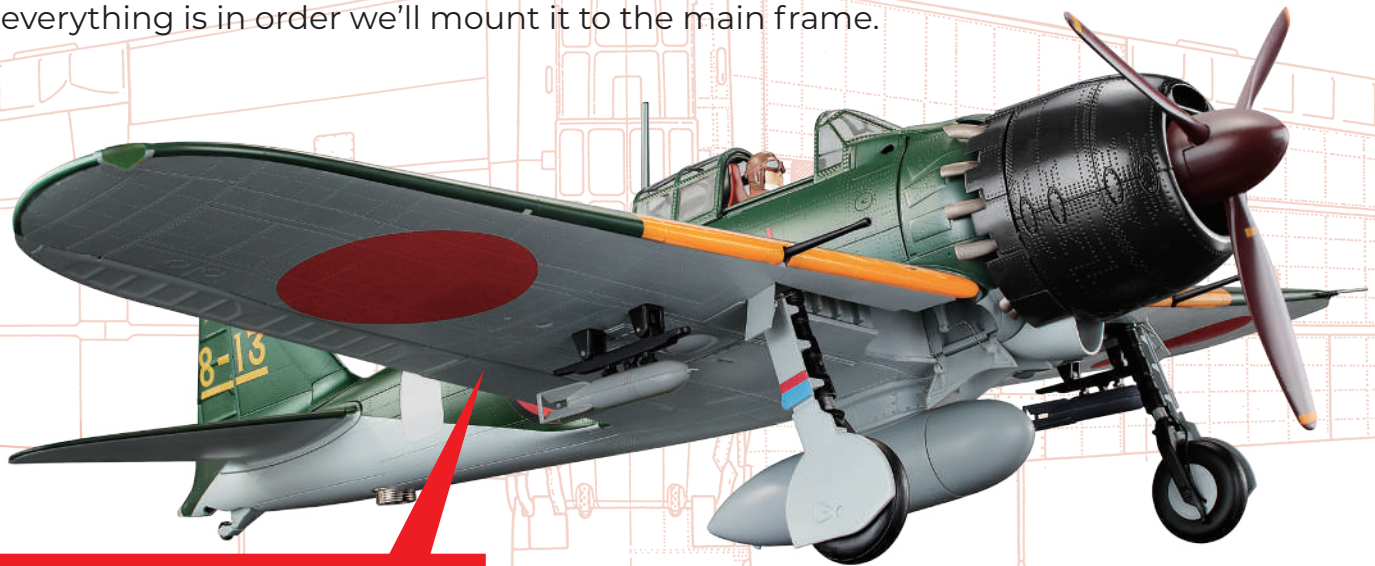

Stage 58 Assembly

Aileron Servomotor

STAGE 58 PARTS

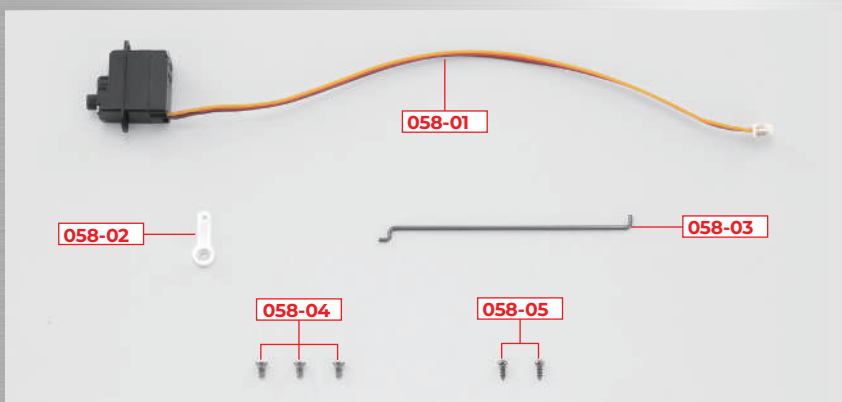

You will also need: screwdriver, battery box, tester, 3 x AAA batteries
 ※058-03 will be used in a later stage, so keep in a safe place for now.
 ※The parts shown may differ slightly from those supplied but this will not affect assembly.

PARTS LIST

	PART	No.	MATERIAL
<input type="checkbox"/>	058-01	1	Servomotor
<input type="checkbox"/>	058-02	1	Plastic
<input type="checkbox"/>	058-03	1	Steel
<input type="checkbox"/>	058-04	3 (1 spare)	Steel
<input type="checkbox"/>	058-05	2 (1 spare)	Steel

STEP 1

Testing the aileron servomotor

← : Glue
- - - : Don't Glue

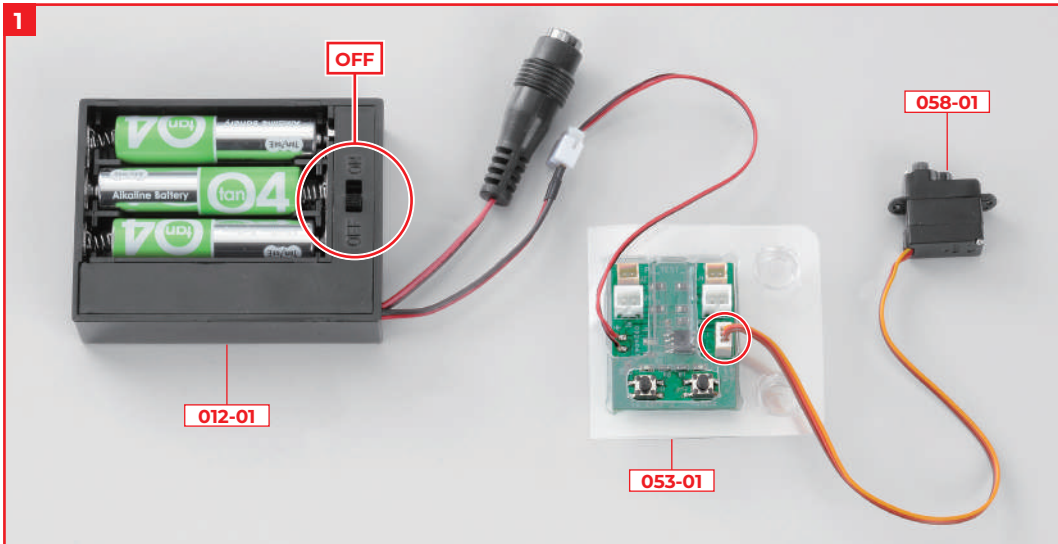

Turn off the power switch on the battery box 012-01, insert three AAA batteries, and connect the power cord connector on the tester 053-01 that came with Stage 53. Insert the connector on the aileron servomotor 058-01 into the servomotor test connector on the tester 053-01.

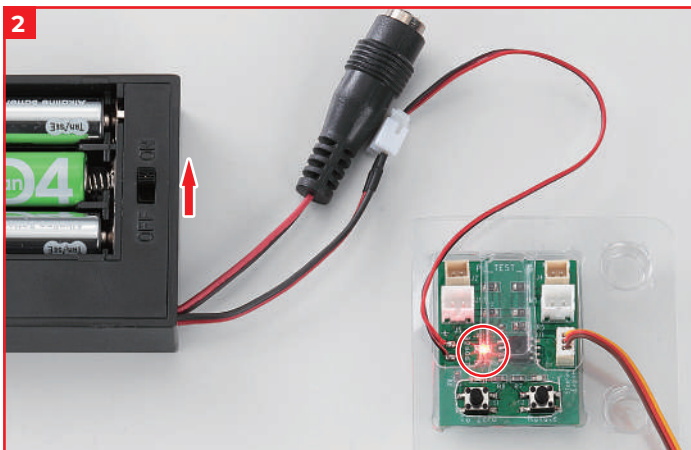

Turn on the power switch on the battery box and check that the power light on the tester 053-01 glows red.

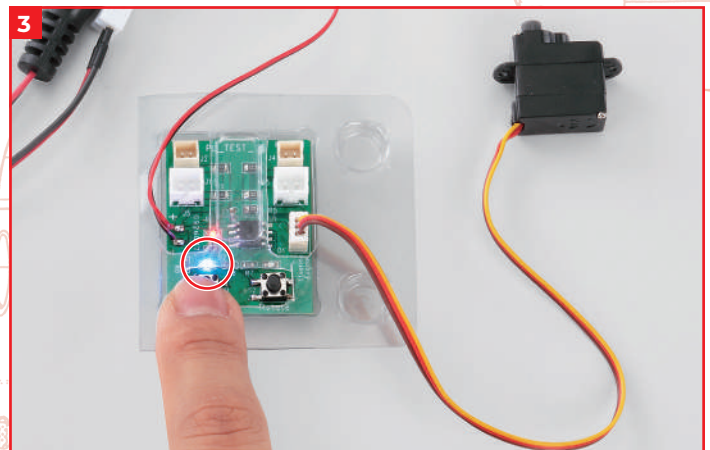

Press the servomotor reset button (left side) on tester 053-01. The operation light above the button glows blue, and the axis of the aileron servomotor 058-01 is set to the neutral position.

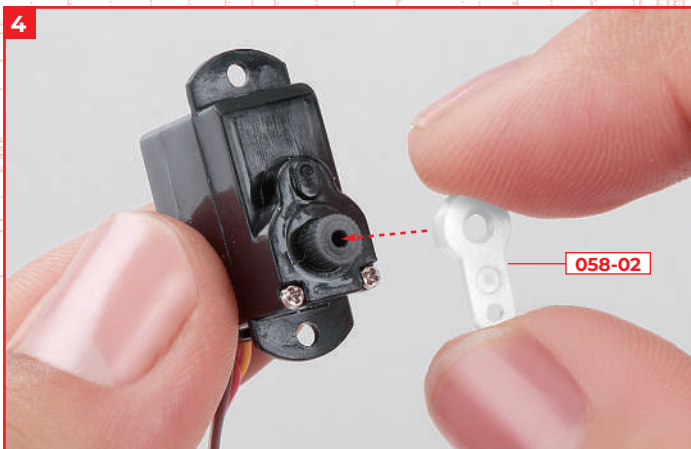

To test the rotation of the axis of the aileron servomotor 058-01, insert the arm 058-02 so that it is easy to see that it is rotating.

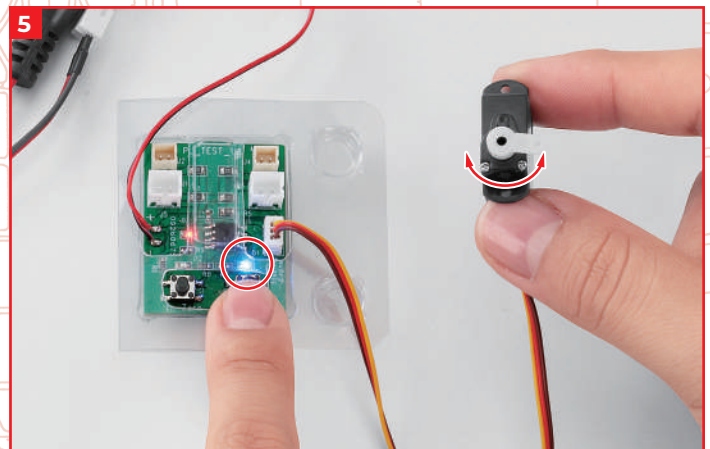

Press the servomotor test button (right side) of tester 053-01. The operation light above the button glows blue, and the arm 058-02 attached to the shaft moves left and right. When the test is over, remove the arm 058-02.

STEP 2

Attaching the aileron servomotor

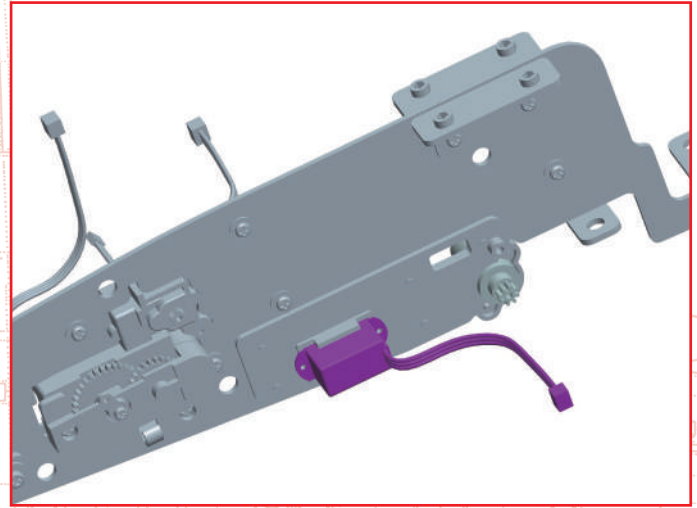
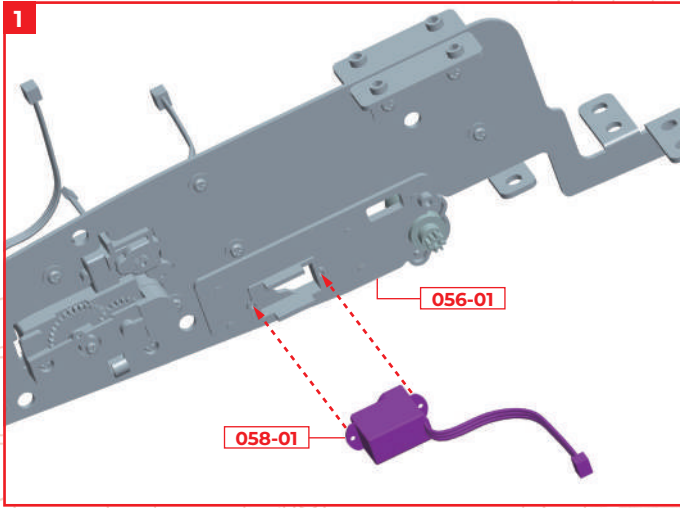

Fit the aileron servomotor 058-01 into the frame part 056-01 attached to the fuselage frame 055-03.

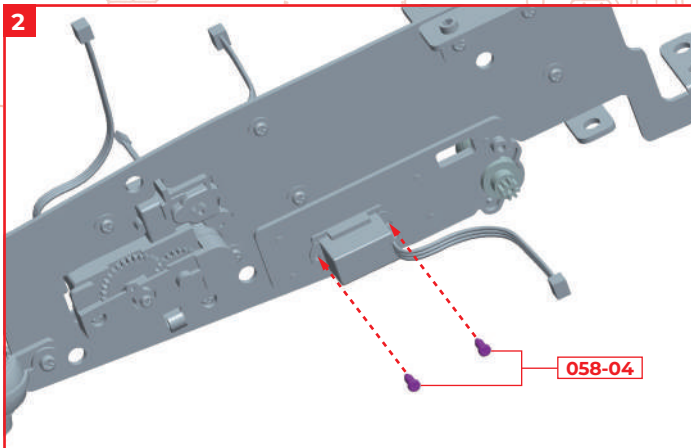

Fix the aileron servomotor 058-01 with 2 x screws 058-04. Be careful not to overtighten the screws as the holes in the aileron servomotor 058-01 are fragile.

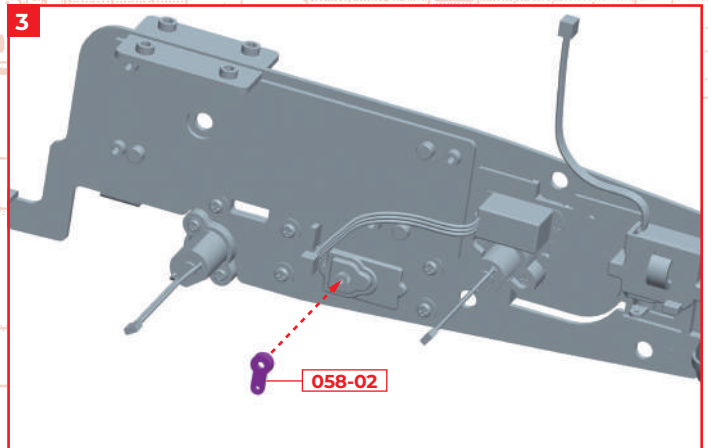

Insert the arm 058-02 onto the shaft of the aileron servomotor 058-01 installed in picture 2. Pay attention to the angle at which the arm 058-02 is inserted.

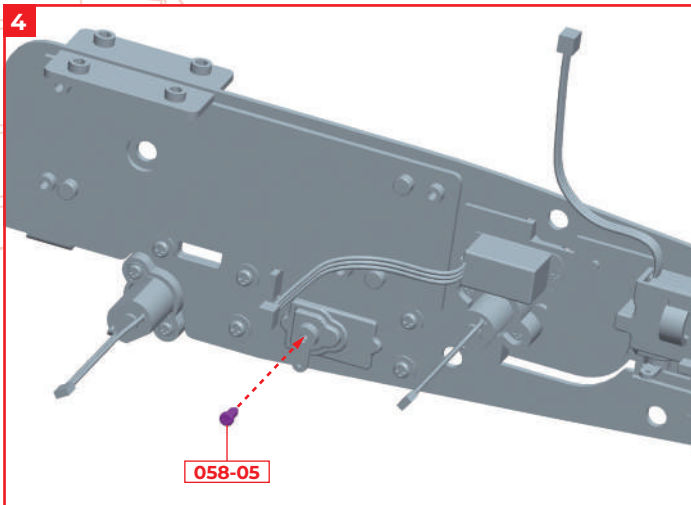

Secure arm 058-02 with 1x screw 058-05.

STAGE COMPLETE

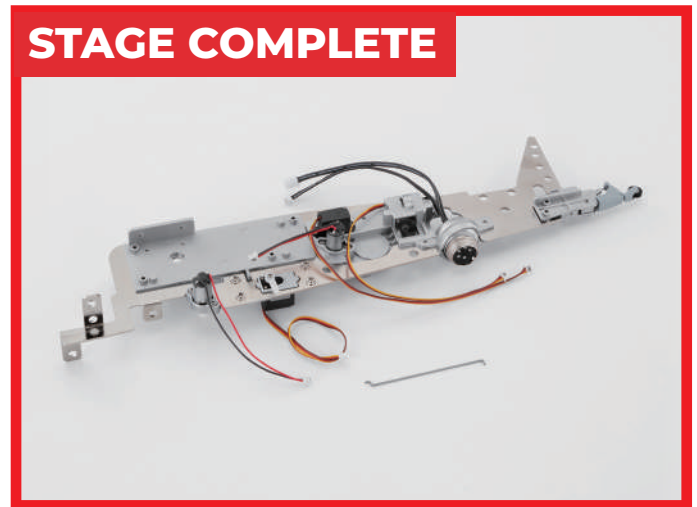

Stage 59: Testing the Elevator Servomotor and Elevator (R) Assembly



Stage 59 Assembly

Elevator (R)

In this stage we'll test the elevator servomotor to ensure it is working properly and then place this in the gearbox for the landing gear. We'll also assemble the right-hand side elevator.

STAGE 59 PARTS

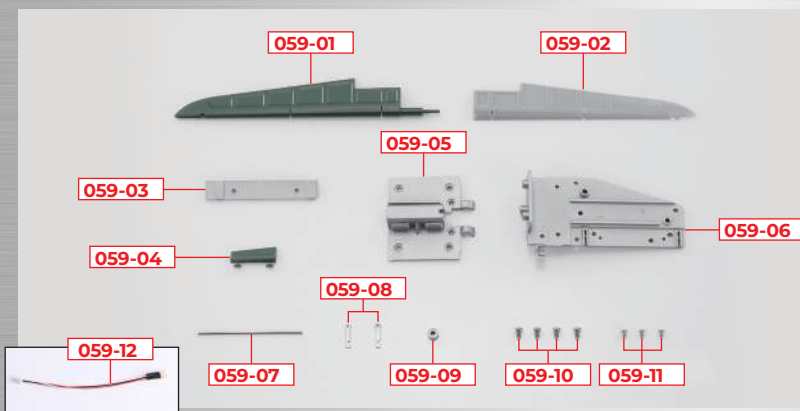

You will also need: screwdriver, superglue
 ※059-05 & 059-10 will be used in later stages, so keep them in a safe place.
 ※The parts shown may differ slightly from those supplied but this will not affect assembly.

PARTS LIST

	PART	No.	MATERIAL
<input type="checkbox"/>	059-01	1	ABS resin
<input type="checkbox"/>	059-02	1	ABS resin
<input type="checkbox"/>	059-03	1	ABS resin
<input type="checkbox"/>	059-04	1	ABS resin
<input type="checkbox"/>	059-05	1	ABS resin
<input type="checkbox"/>	059-06	1	ABS resin
<input type="checkbox"/>	059-07	1	Steel
<input type="checkbox"/>	059-08	2	Steel
<input type="checkbox"/>	059-09	1	Steel
<input type="checkbox"/>	059-10	4 (1 spare)	Steel
<input type="checkbox"/>	059-11	3 (1 spare)	Steel
<input type="checkbox"/>	059-12	1	Adaptor

STEP 1

Testing and placing the servomotor

← : Glue
 - - - : Don't Glue

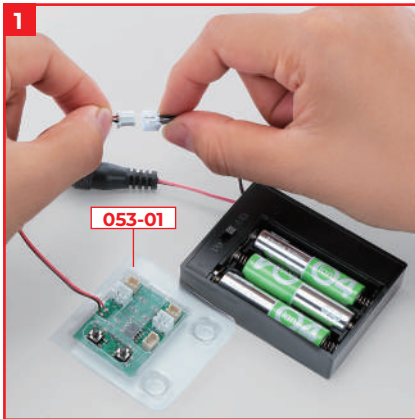

Turn off the power switch on the battery box that came with stage 12, insert three AAA batteries, and connect it to the tester 053-01.

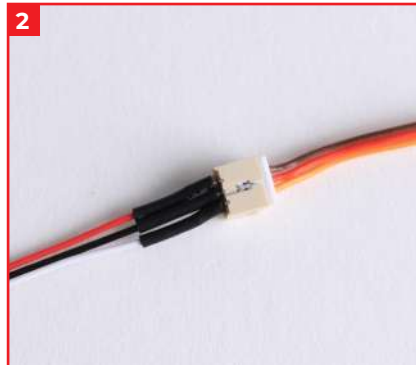

Insert the connector on the servomotor 052-01 that came with stage 52 into one end of the adaptor 059-12. Insert the other end of the adaptor 059-12 into the connector on the tester 053-01.

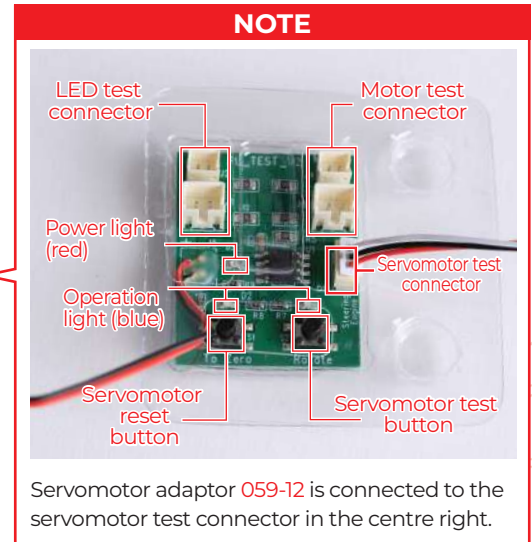

Servomotor adaptor 059-12 is connected to the servomotor test connector in the centre right.



When the power switch on the battery box is turned on, the power light on the tester 053-01 lights up in red.

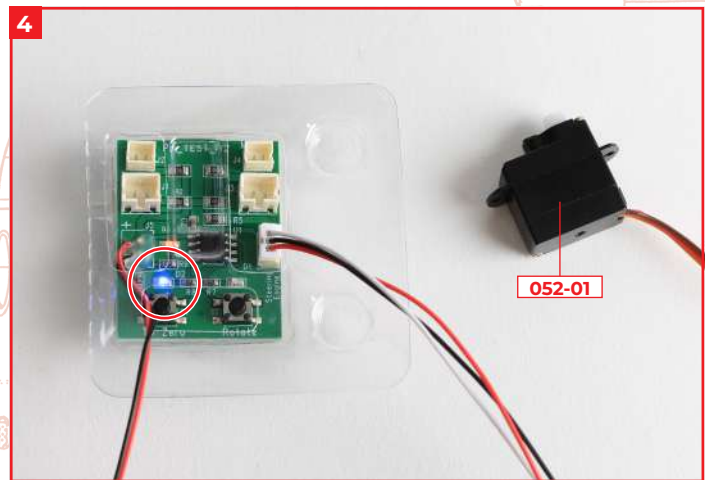

Press the servomotor reset button on the tester 053-01. The operation light above the button lights up in blue, and the axis of the servo motor 052-01 is set to the neutral position.

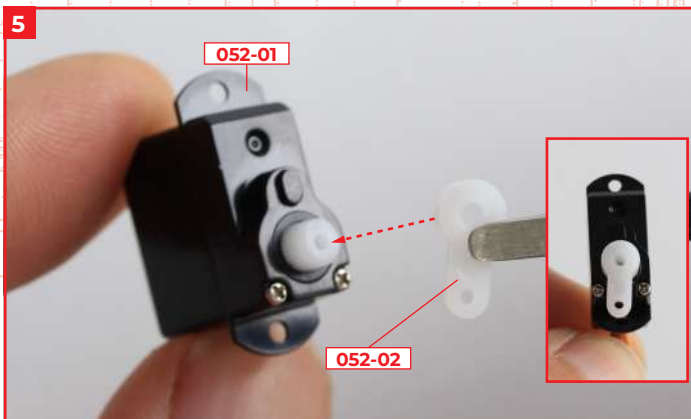

To test the rotation of the servomotor 052-01, insert the arm 052-02 that came with stage 52 in the direction shown in the photo so that you can easily see that it is rotating.

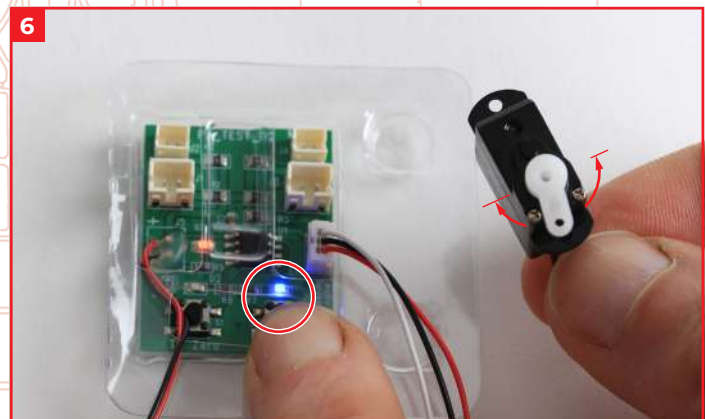

Press the servomotor test button on tester 053-01. Confirm that the operation light above the button lights up in blue and that the arm 052-02 attached to the shaft rotates about 90 degrees to the left and right. After the test, remove the arm 052-02 and keep it in a safe place.

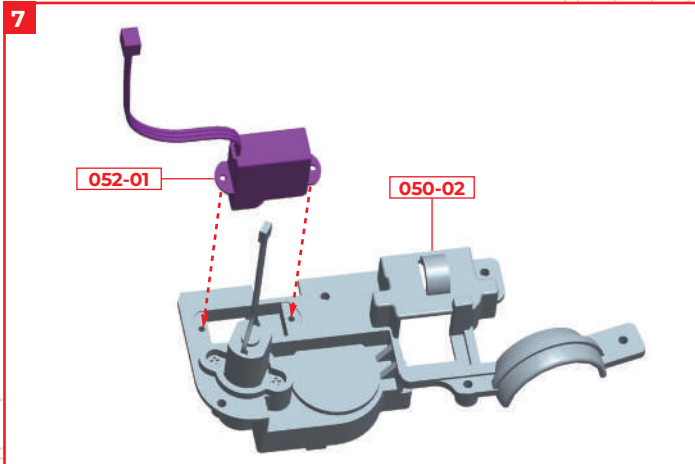

Fit the servomotor 052-01 into the gearbox 050-02 assembled in stage 51. At this point, the wire of the servomotor should be on the left side.

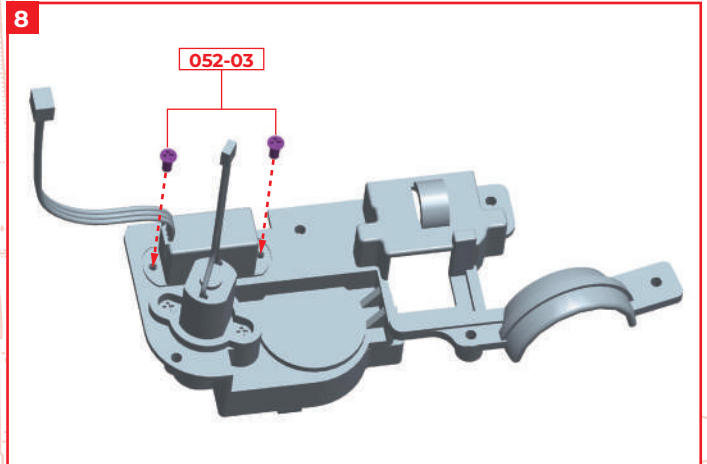

Fix in place with the 2 x screws 052-03 that came with stage 52.

STEP 2

Assembling the elevator (R)

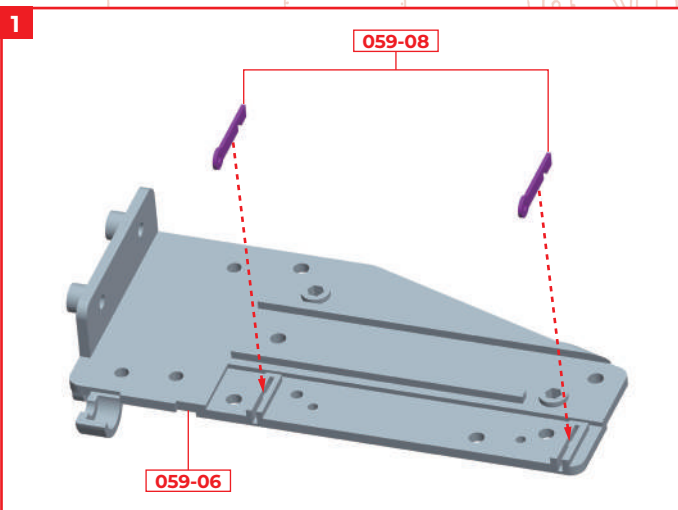

Fit the notches on hinges 059-08 into frame 059-06 with the notches facing down.

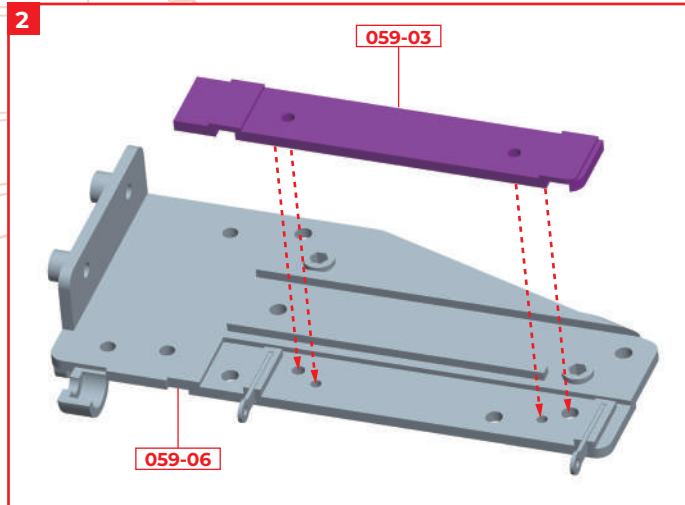
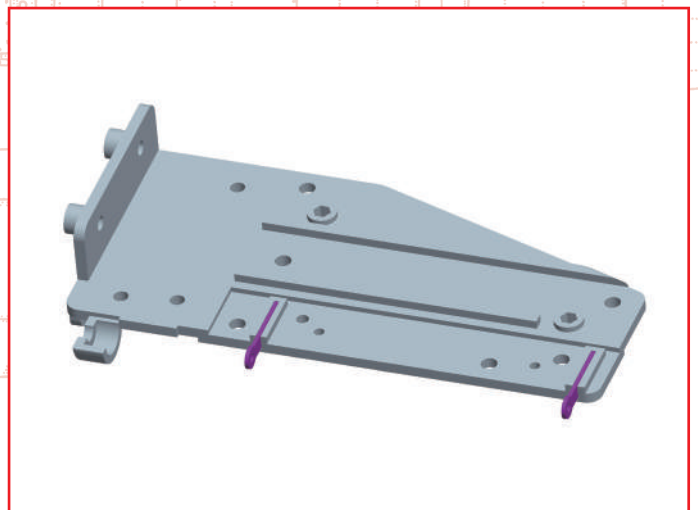

Fit the hinge cover 059-03 into the frame 059-06 with the two protrusions facing down.

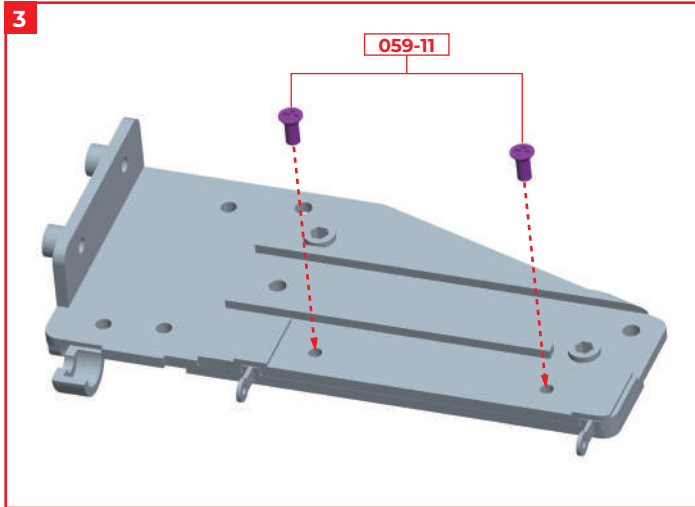

Secure the hinge cover 059-03 with 2 x screws 059-11.

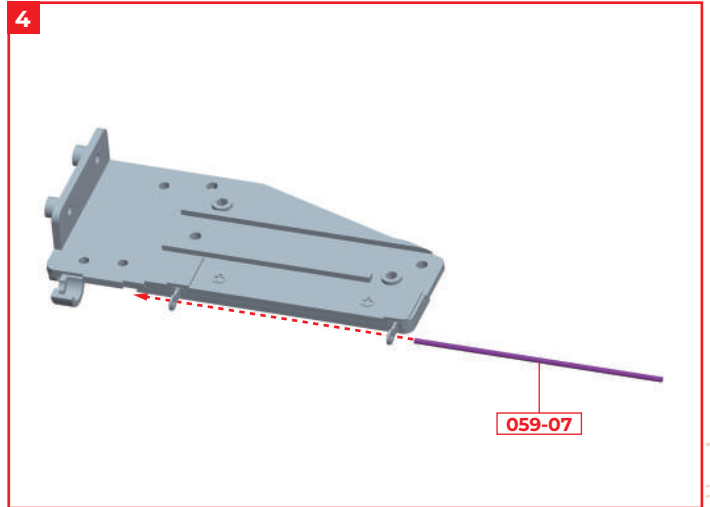

Feed shaft 059-07 through the holes in the two hinges 059-08.

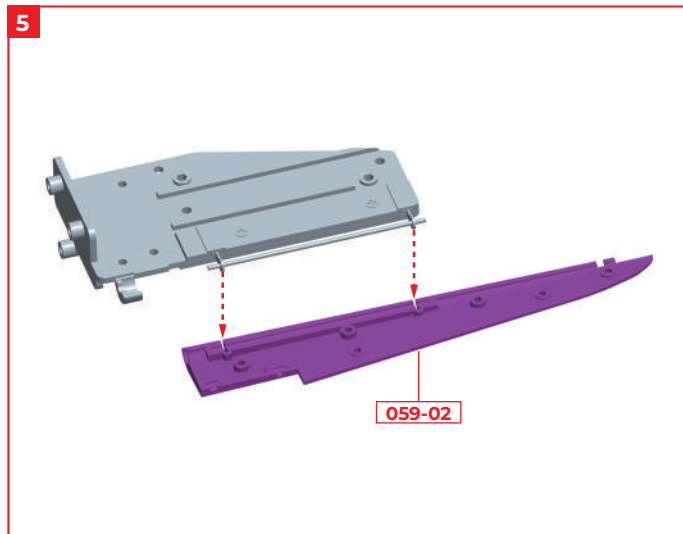

Fit the two hinges 059-08 and shaft 059-07 into the groove on the underside of the elevator (right) 059-02.

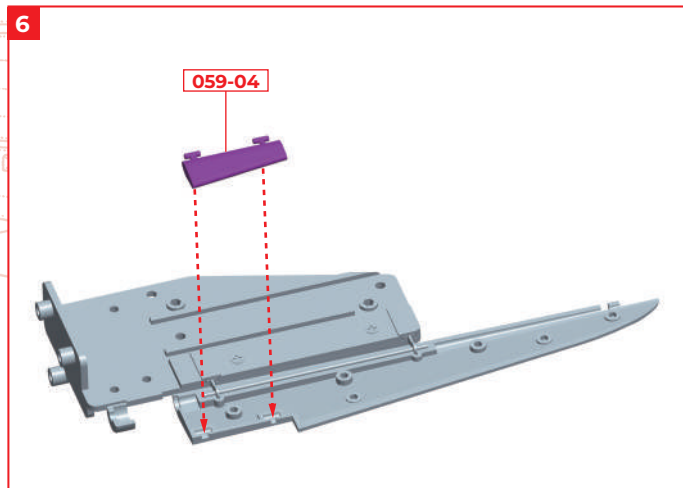

Fit the elevator trim tab 059-04 into the elevator (right) underside 059-02.

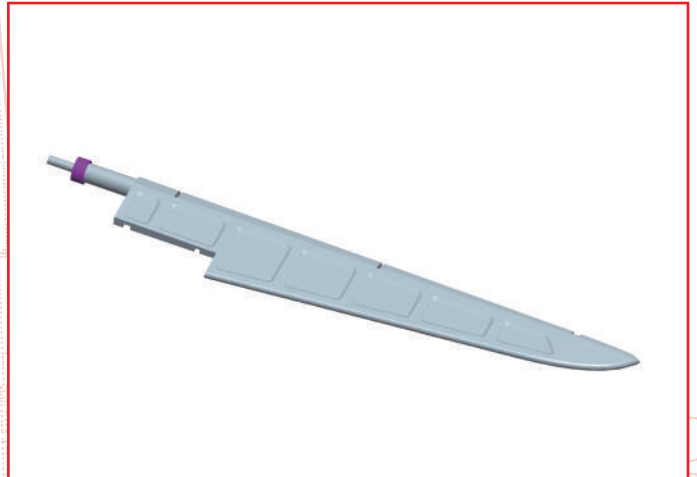
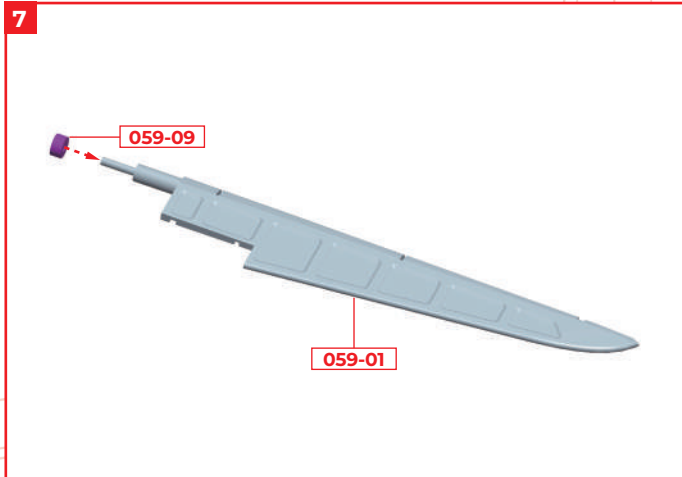

Fit the bearing 059-09 onto the shaft of the elevator (right) topside 059-01.

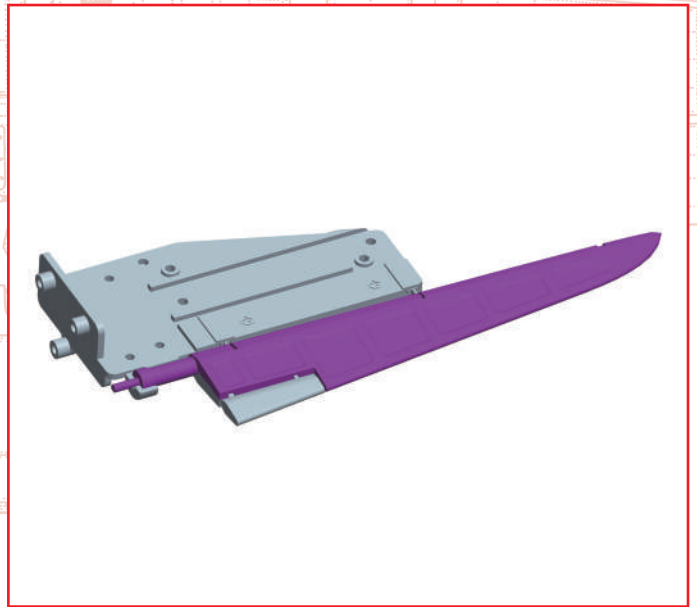
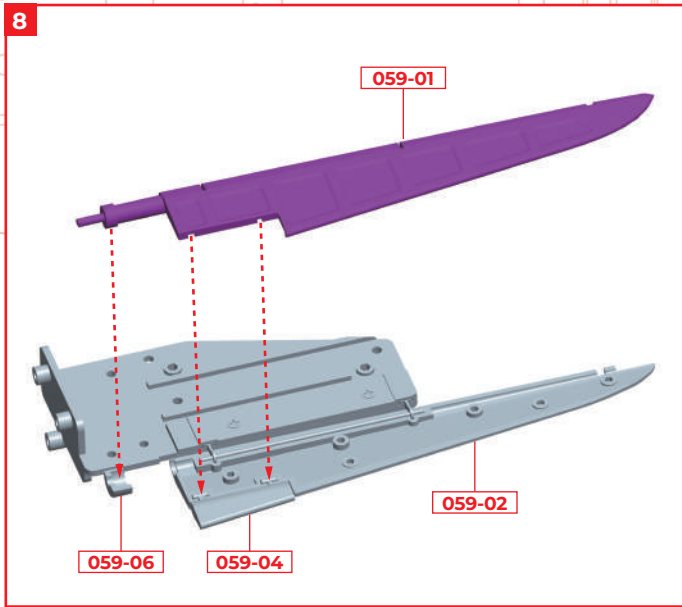

Fit the elevator (right) underside 059-02 of the unit assembled in 6 and the elevator (right) topside 059-01 assembled in 7. If the fit is loose, glue the top and bottom with a small amount of superglue.

STAGE COMPLETE



Stage 60: Rudder Assembly

In this stage we'll assemble the rudder and then, after installing the tail lights, attach this to the aircraft frame and connect the dedicated servomotor. Make sure the wire doesn't snap when connecting the LED used for the tail lights.

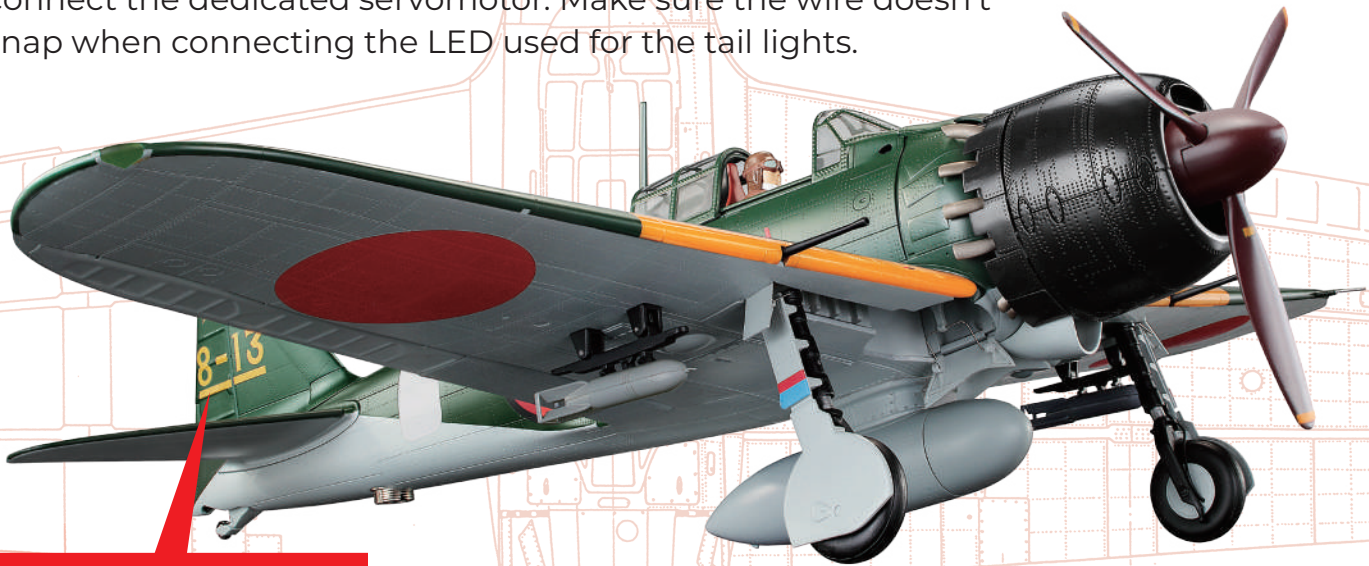

Stage 60 Assembly

Rudder

STAGE 60 PARTS

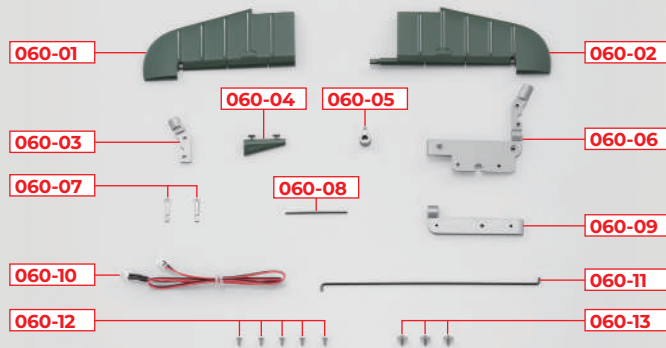

PARTS LIST

	PART	No.	MATERIAL
<input type="checkbox"/>	060-01	1	ABS resin
<input type="checkbox"/>	060-02	1	ABS resin
<input type="checkbox"/>	060-03	1	ABS resin
<input type="checkbox"/>	060-04	1	ABS resin
<input type="checkbox"/>	060-05	1	ABS resin
<input type="checkbox"/>	060-06	1	ABS resin
<input type="checkbox"/>	060-07	2	Steel
<input type="checkbox"/>	060-08	1	Steel
<input type="checkbox"/>	060-09	1	ABS resin
<input type="checkbox"/>	060-10	1	LED
<input type="checkbox"/>	060-11	1	Steel
<input type="checkbox"/>	060-12	5 (1 spare)	Steel
<input type="checkbox"/>	060-13	3 (1 spare)	Steel

You will also need: screwdriver, superglue
 ※The parts shown may differ slightly from those supplied but this will not affect assembly.

STEP 1

Assembling the rudder

← : Glue
- - - : Don't Glue

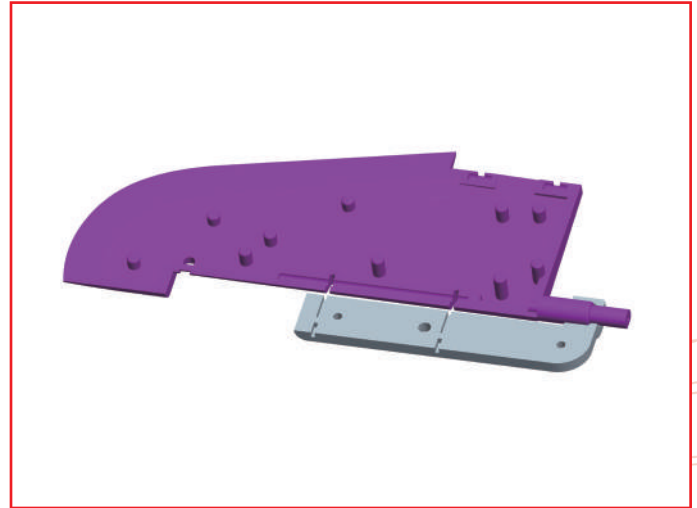
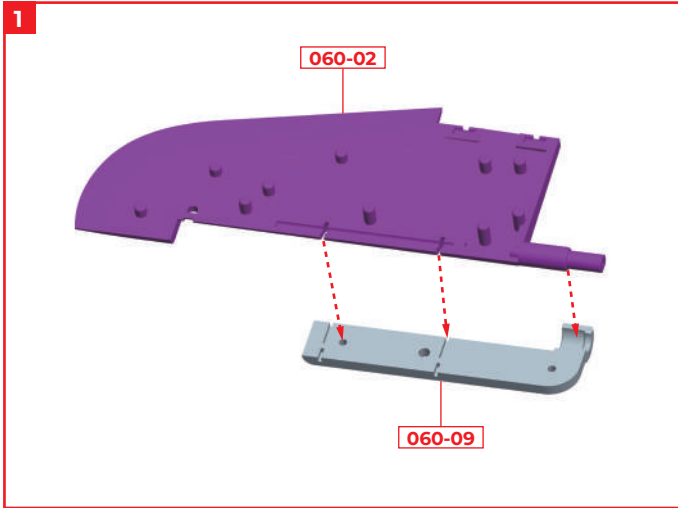

Fit the rudder (right side) 060-02 into the frame 060-09.

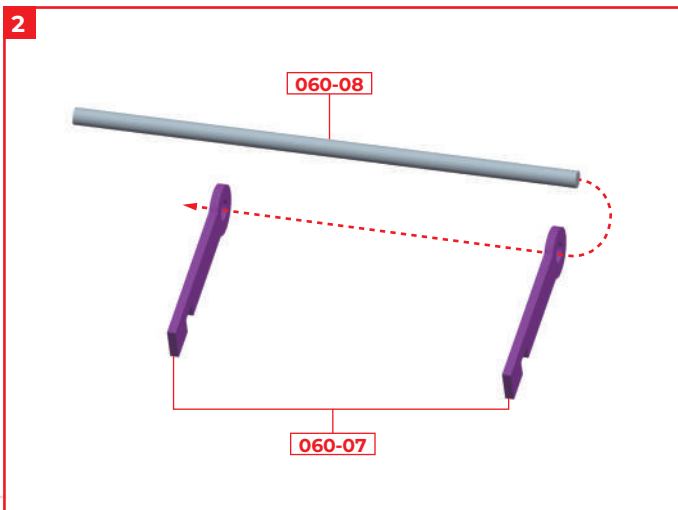

Take hinges 060-07 and feed the shaft 060-08 through the two holes.

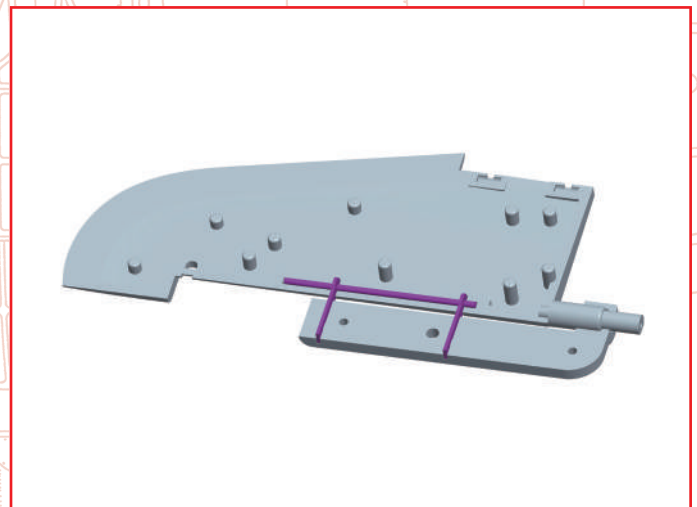
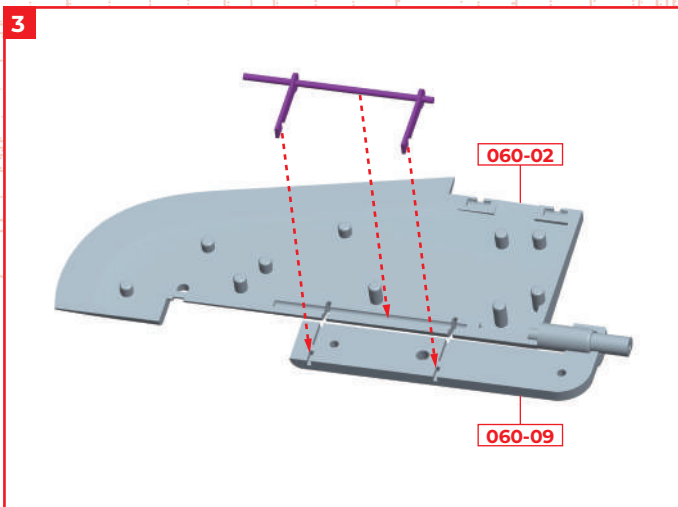

Fit the two hinges 060-07 and shaft 060-08 assembled in 2 onto the frame 060-09 and rudder (right side) 060-02 assembled in 1.

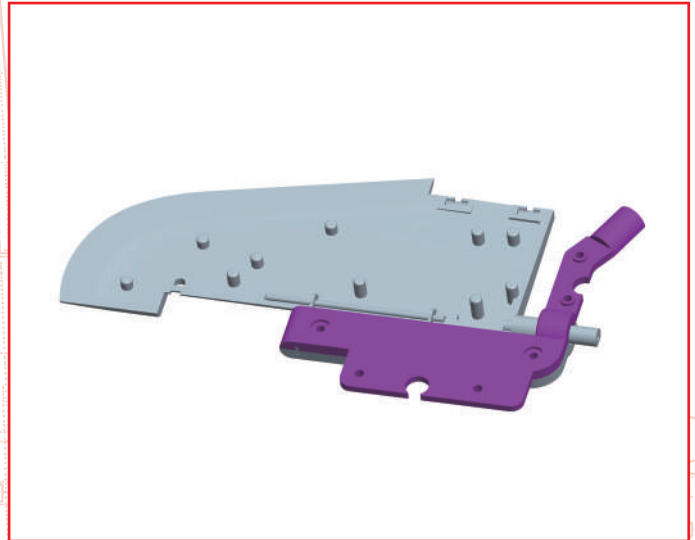
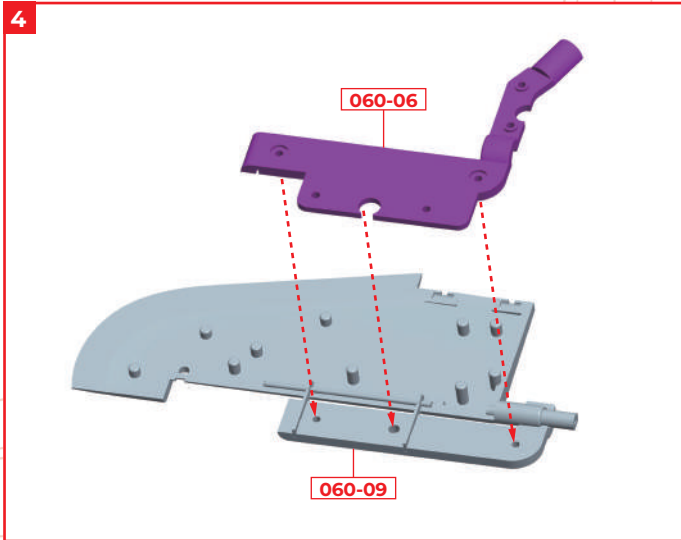

Align the two screw holes on the frame 060-06 with one protrusion on the 060-09 assembled in step 3 and fit together.

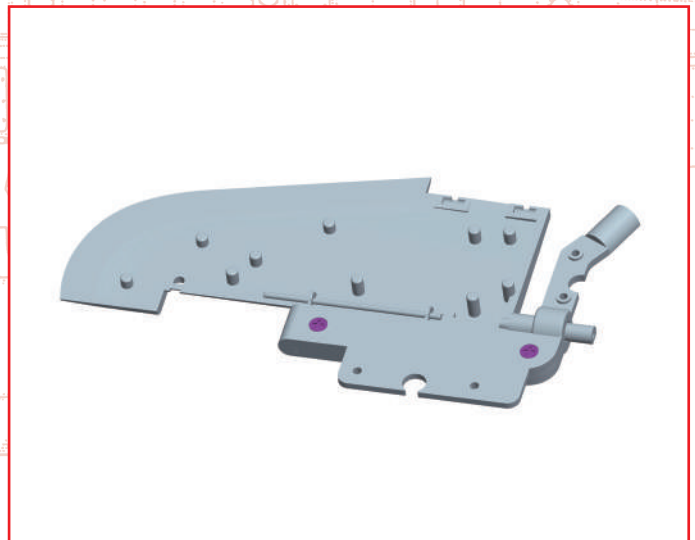
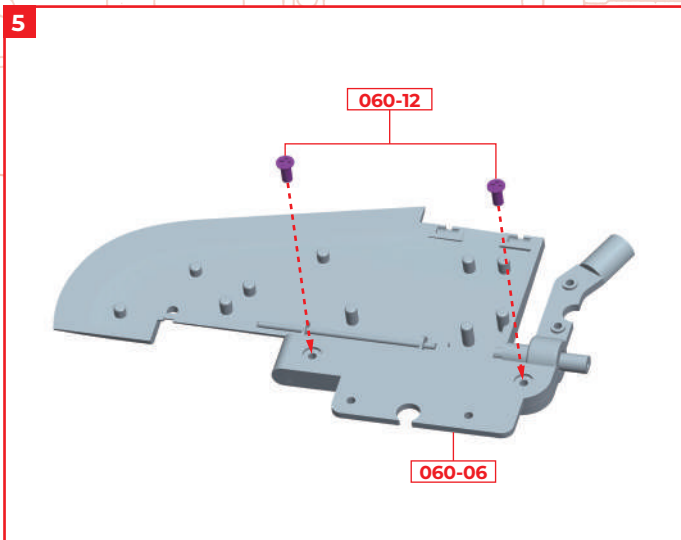

Secure the frame 060-06 and frame 060-09 with 2 x screws 060-12.

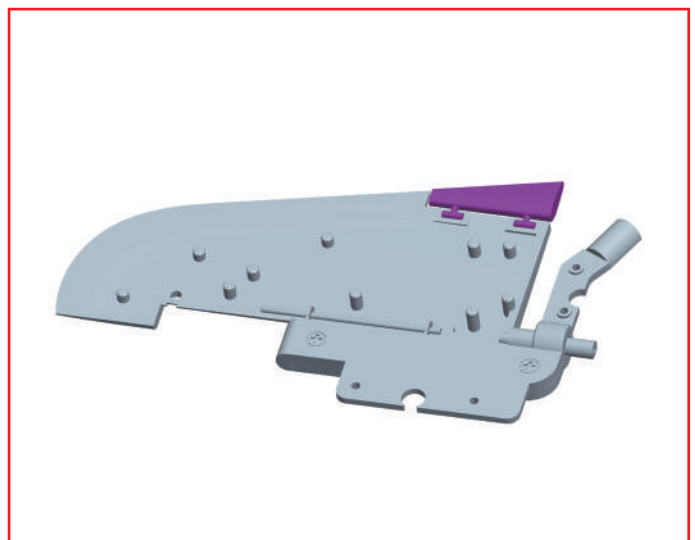
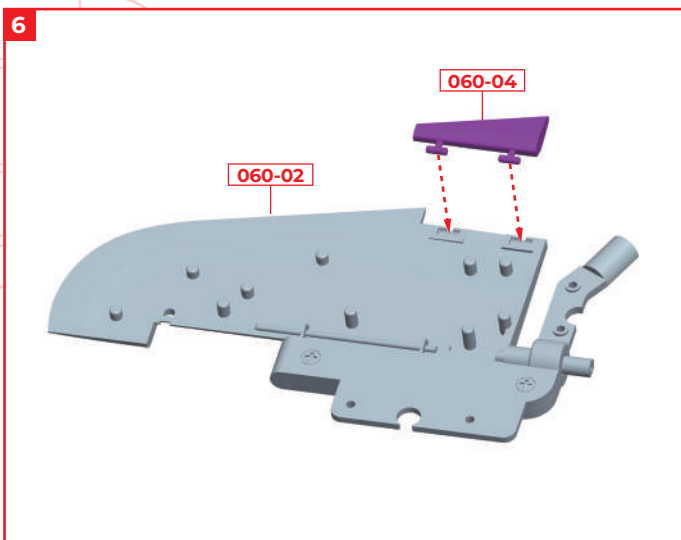

Insert the rudder adjustment tab 060-04 into the rudder (right side) 060-02.

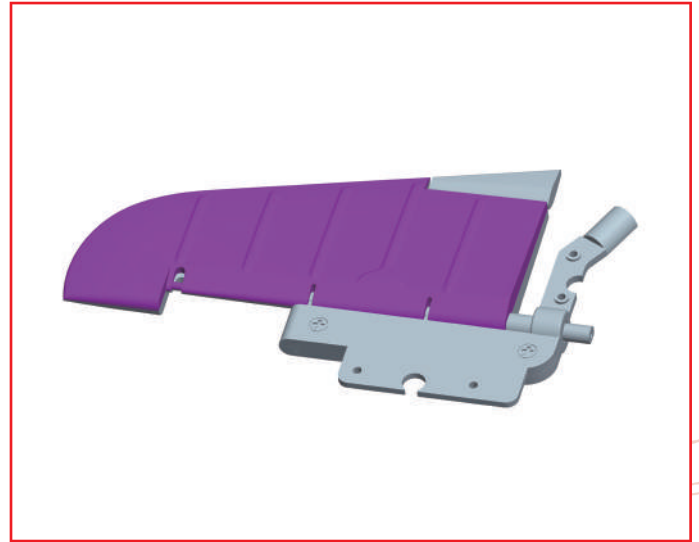
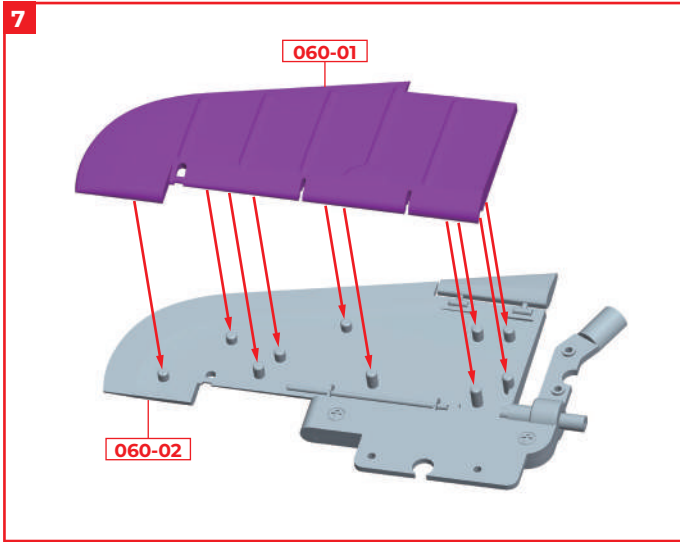

Align and glue the 10 protrusions and holes on the right side of the rudder 060-02 and the left side of the rudder 060-01.

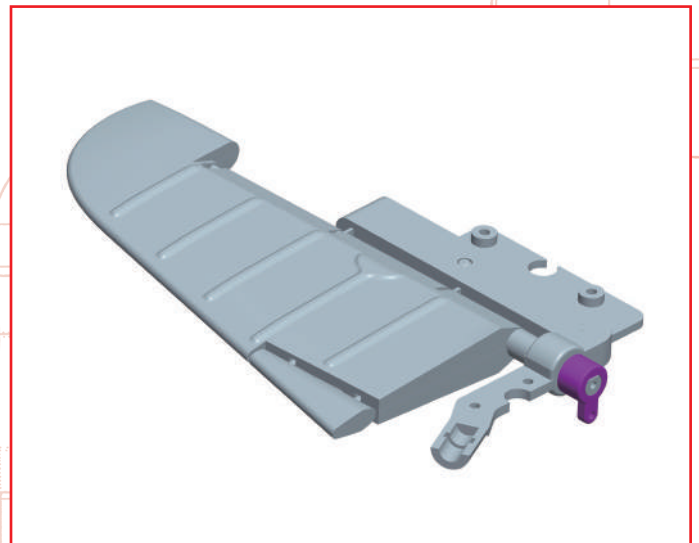
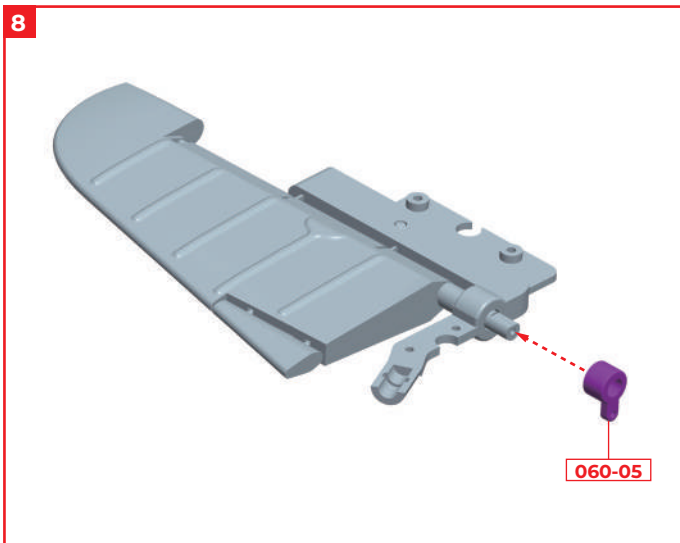

Align the shaft of the rudder (right side) 060-02 with the D-shaped cross section of the arm 060-05 and push together.

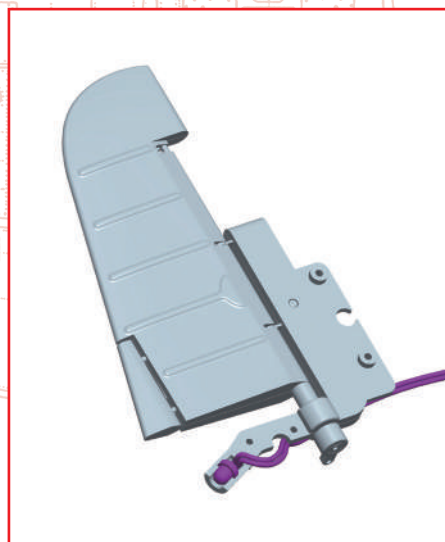
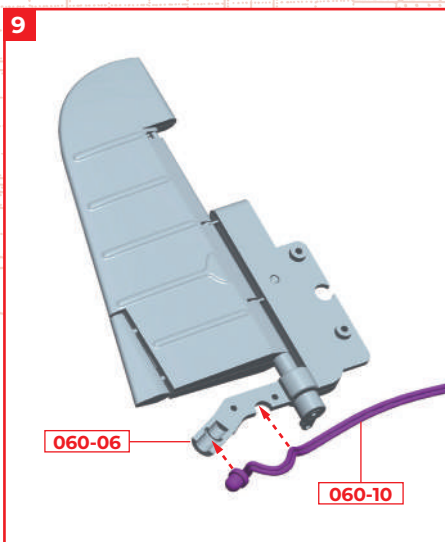

Bend the base of LED 060-10, which is the taillight, 90 degrees, and then fit it into the frame 060-06.

NOTE

When bending the base of the tail light LED wire, firstly fit 060-10 (the light and wire) in the frame and then gently push and bend the base of the wire. This will make it easier to get the desired result.

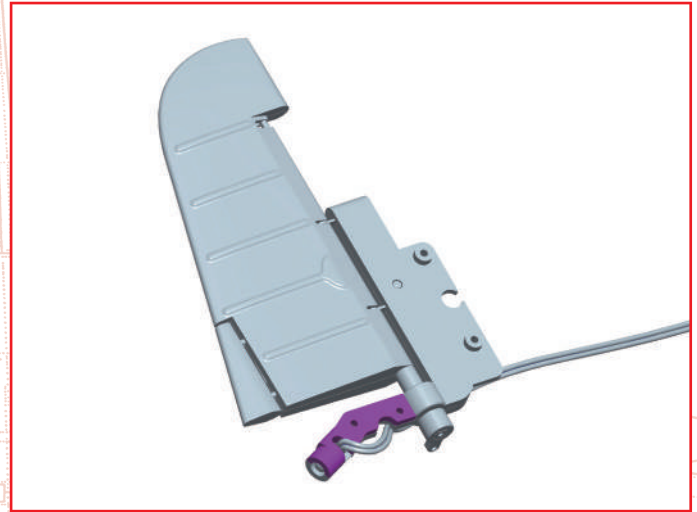
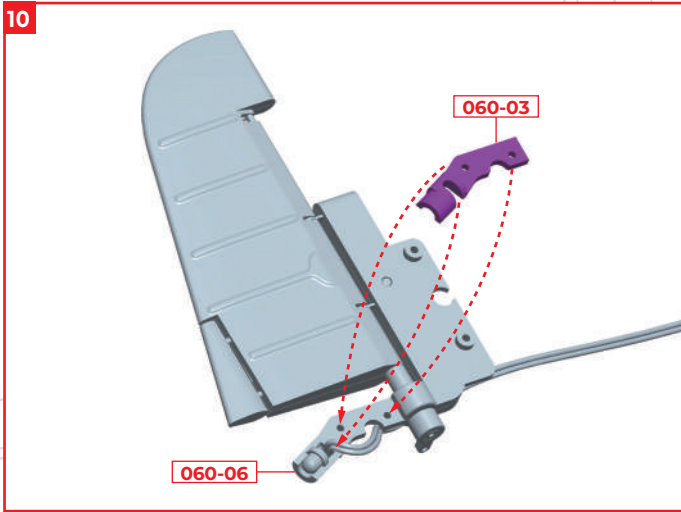

Fit the frame 060-03 into the part of the frame 060-06 where the taillight LED 060-10 is installed. The wire for LED 060-10 should be on the left side when viewed from behind the rudder as shown in the figure.

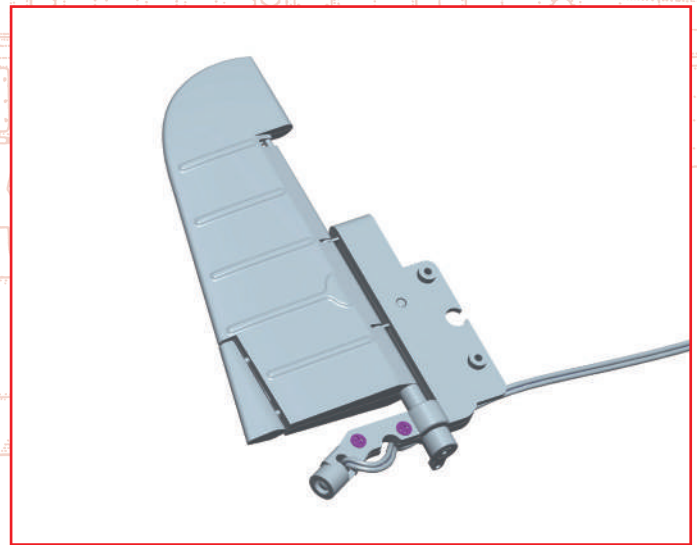
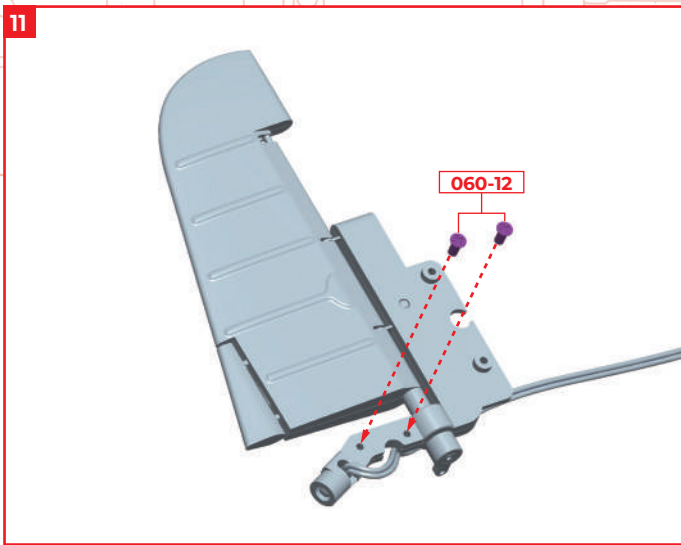

Secure the frame 060-03 and frame 060-06 with 2 x screws 060-12.

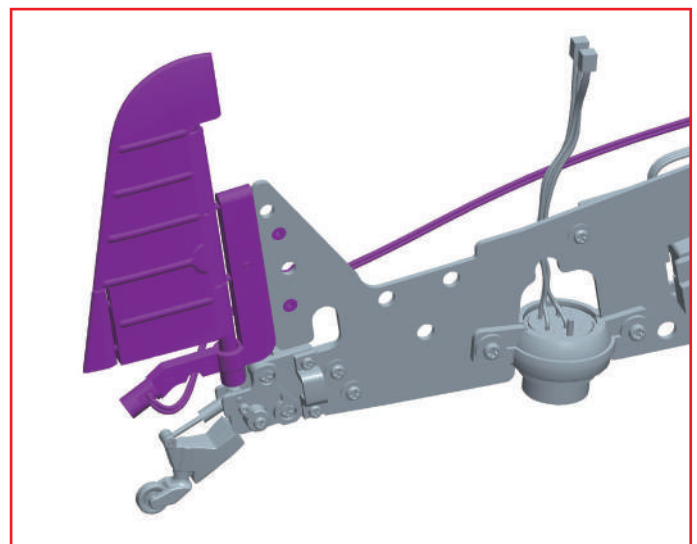
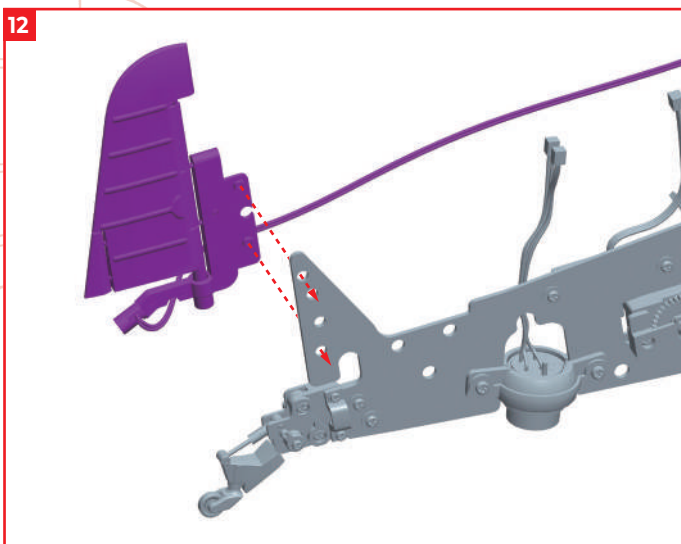

Fit the rudder unit assembled in 11 into the fuselage frame 055-03

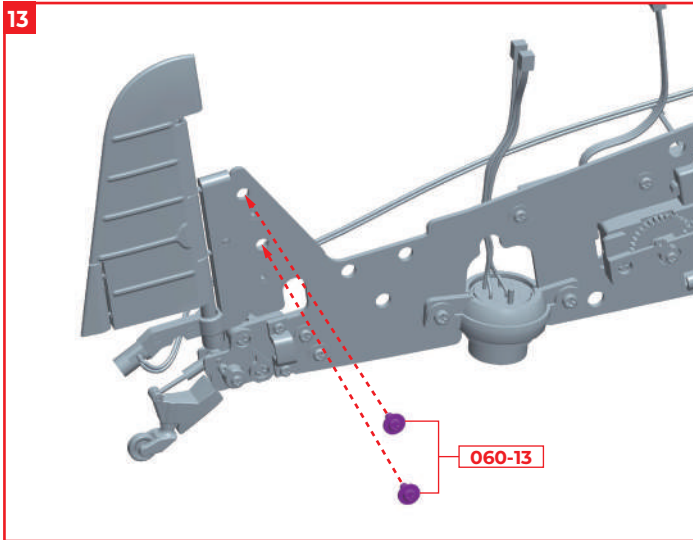

Fix the rudder unit with 2 x screws 060-13.

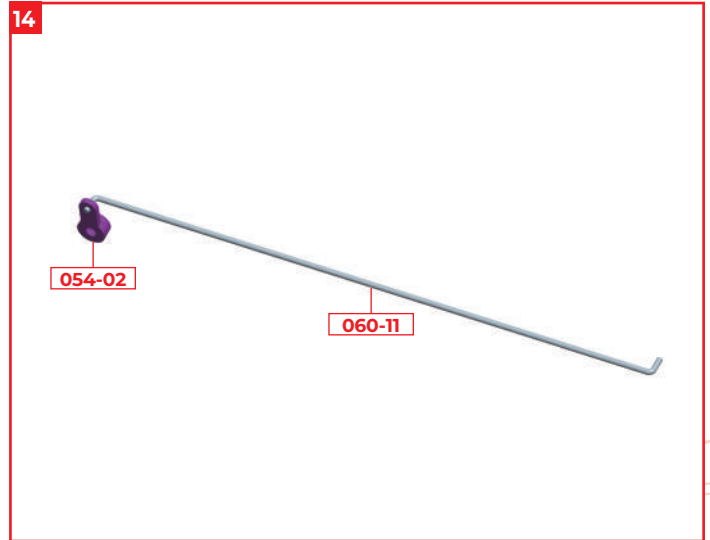

Insert the rod 060-11 into the hole of the arm 054-02 supplied with Stage 54.

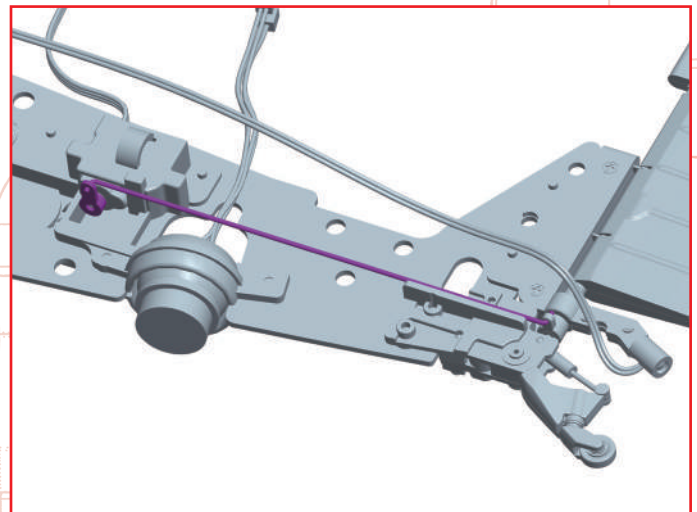
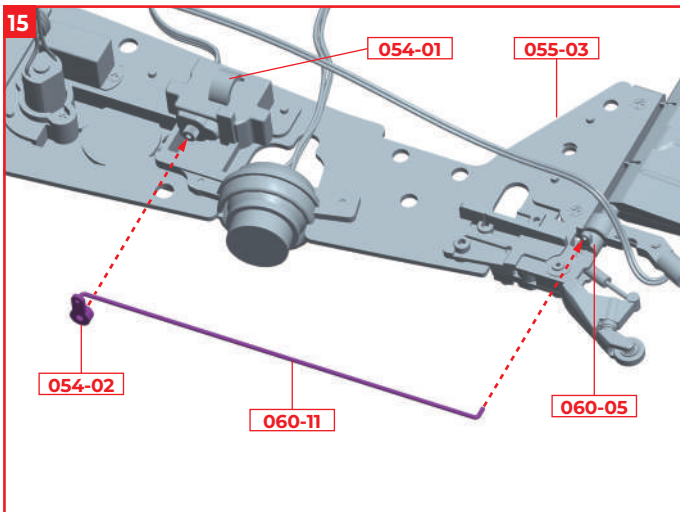

Fit the arm 054-02 into the rudder servomotor 054-01 attached to the gearbox on the fuselage frame 055-03 in Stage 55. Insert the rod 060-11 into the arm 060-05 attached in 8.

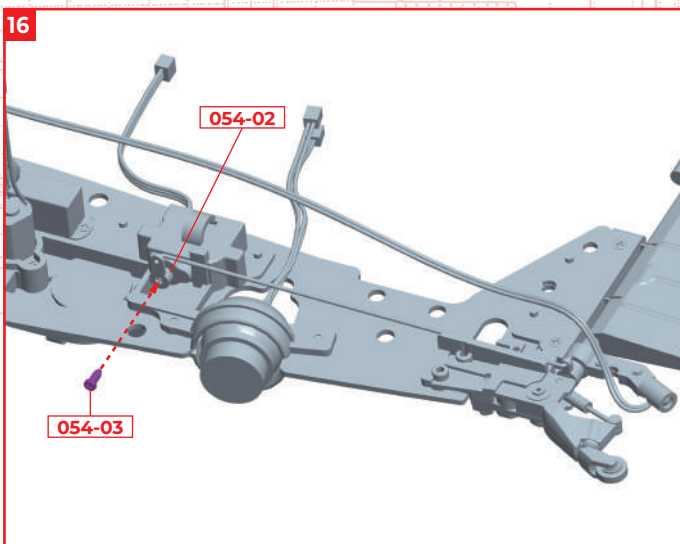

Fix the arm 054-02 with 1 x screw 054-03 that came with stage 54.

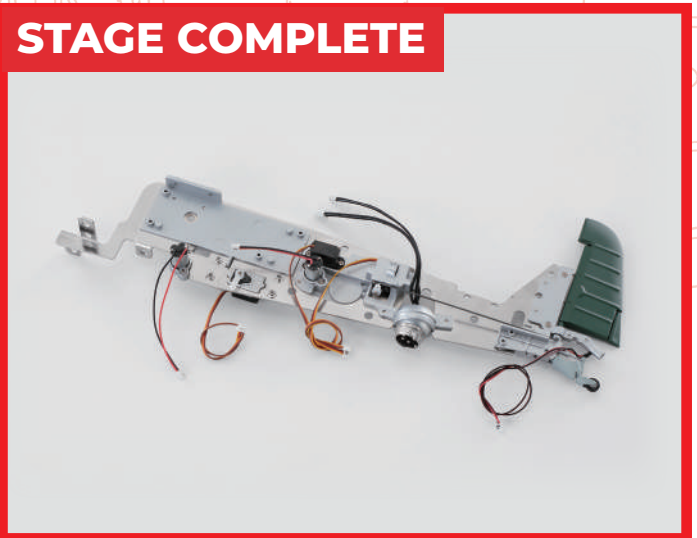

Stage 61: Assembling the Limit Switch and Display Pedestal

In this stage we'll be assembling another limit switch as well as the base to place it. Pay extra attention to the position and direction both the metal parts for the limit switch and pedestal are facing.



Stage 61 Assembly

Limit Switch / Pedestal

STAGE 61 PARTS

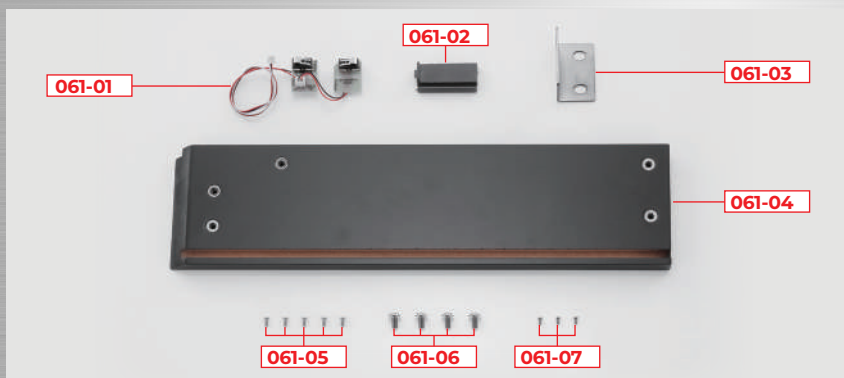

You will also need: screwdriver

※**061-06** Two of these screws will be used in a later stage. Keep them in a safe place.

※The parts shown may differ slightly from those supplied, but this will not affect assembly.

PARTS LIST

	PART	No.	MATERIAL
<input type="checkbox"/>	061-01	1	Limit switch
<input type="checkbox"/>	061-02	1	ABS resin
<input type="checkbox"/>	061-03	1	Steel
<input type="checkbox"/>	061-04	1	MDF
<input type="checkbox"/>	061-05	5 (1 spare)	Steel
<input type="checkbox"/>	061-06	4	Steel
<input type="checkbox"/>	061-07	3 (1 spare)	Steel

STEP 1

Assembling the limit switch

← : Glue
 - - - : Don't Glue

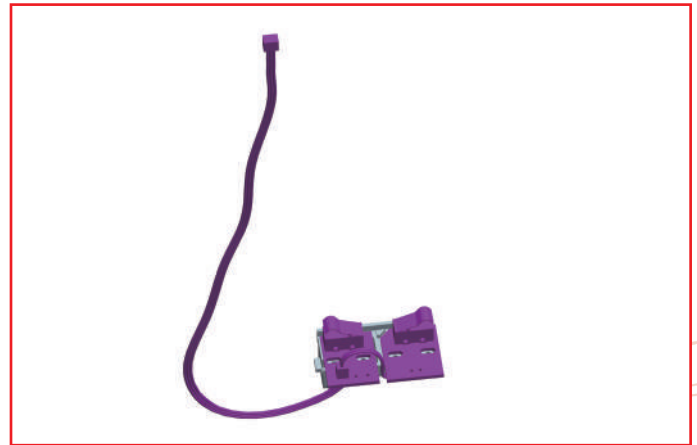
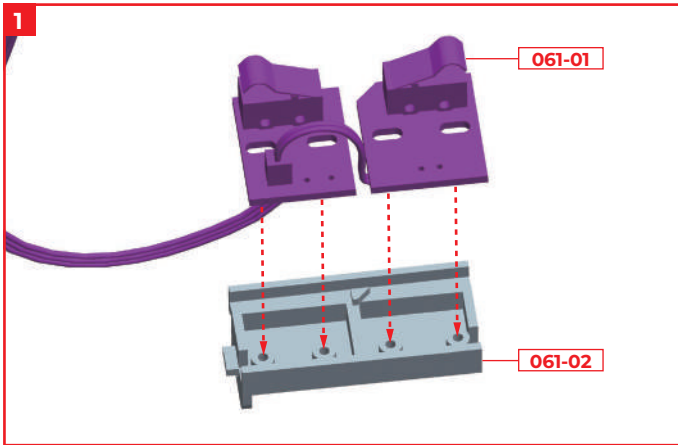

Fit the limit switch 061-01 into the frame 061-02. Align the cut corners of the board on the limit switch 061-01 with the triangular protrusions of the frame 061-02.

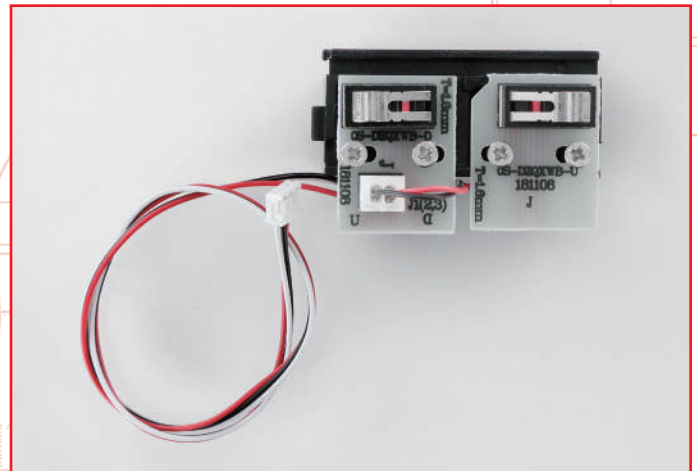
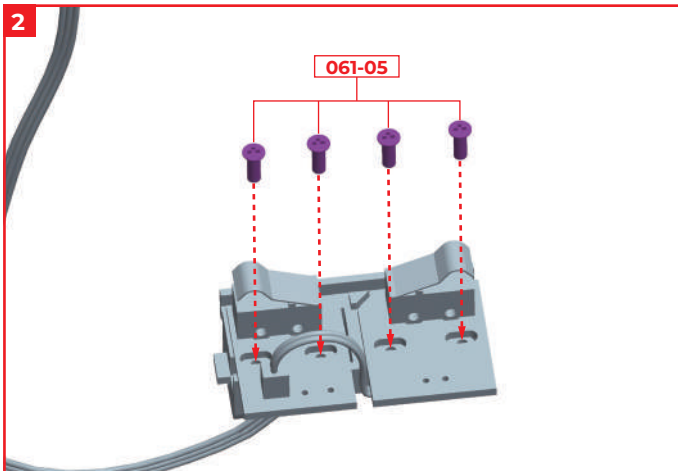

Fix the limit switch 061-01 with 4 x screws 061-05. There is a little room on the left and right of the screw holes, so align the frame and switch to fix them.

STEP 2

Assembling the pedestal

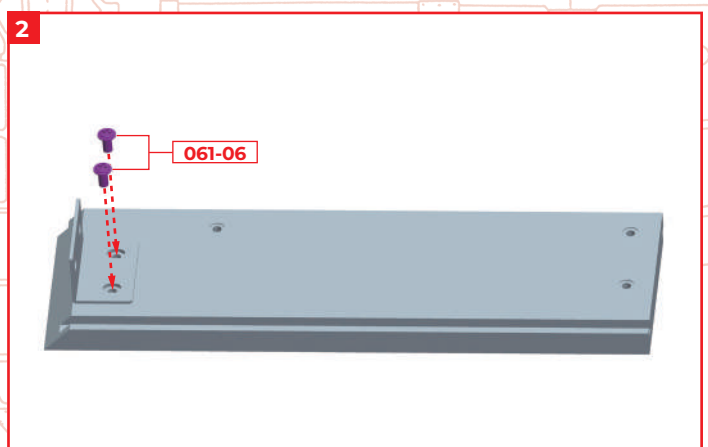
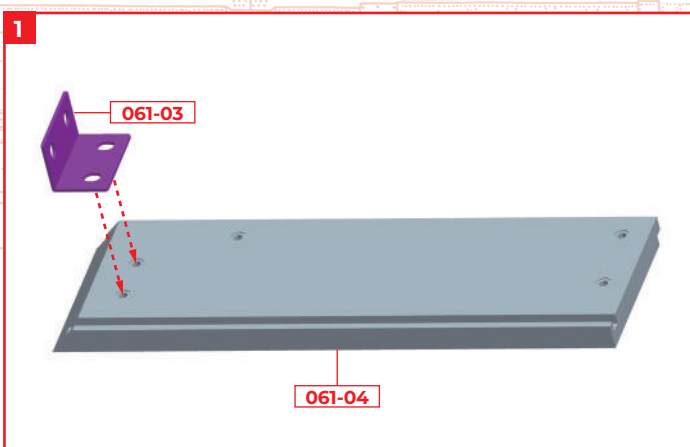

Align the metal fitting 061-03 with the holes on the pedestal frame 061-04.

Fix the pedestal frame 061-04 and the metal fitting 061-03 with 2 x screws 061-06. Keep the remaining screws 061-06 as they will be used in the next and subsequent stages.

STAGE COMPLETE



Adjustment of Stage 51.

If the two screws **051-03** that fixed the motor **051-01** in Stage 51 are loose, replace them with the special screws **061-07** that come with this stage.

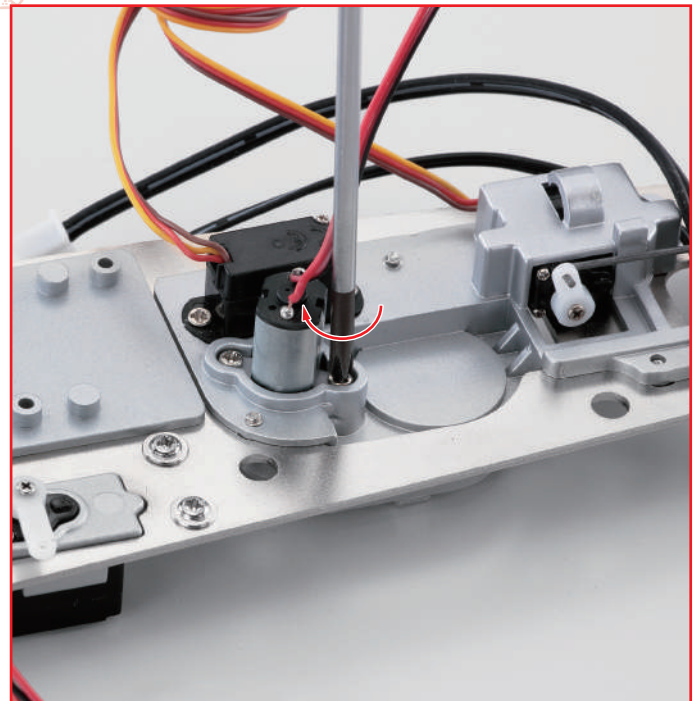
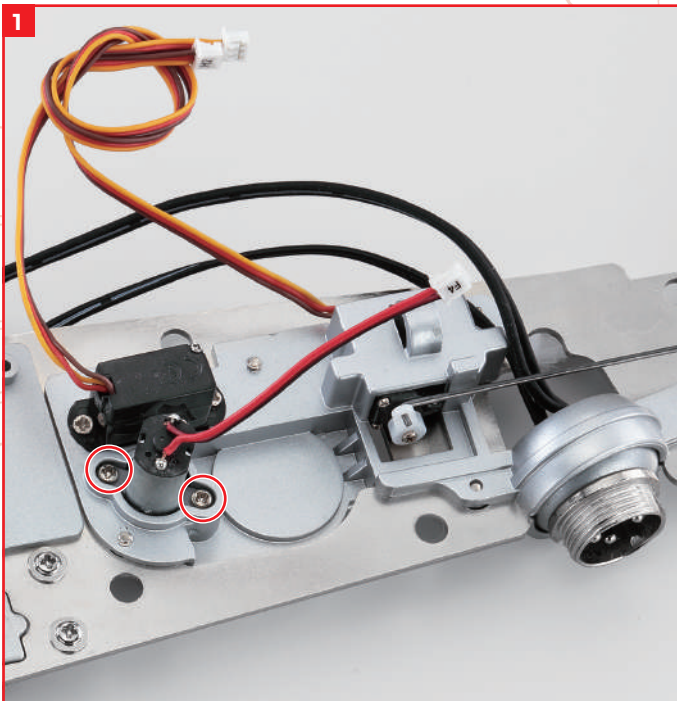

Remove the 2 x screws **051-03** that secure the motor **051-01**, and fix it again with the 2 x screws **061-07**.