

MITSUBISHI A6M ZERO FIGHTER



Pack 08 | Build Instructions

Your 1:18 model of the Japanese Zero is reproduced in the most exquisite detail, with electronics allowing you to recreate aeronautical operations such as take-off and landing, turning, firing and night combat. Lights, machine-gun and propeller sounds bring your legendary fighter plane to life.

In your eighth model pack, you will assemble:

STAGE 62: ELEVATOR ASSEMBLY

STAGE 63: DISPLAY PEDESTAL ASSEMBLY

**STAGE 64: INSTALLING THE CIRCUIT BOARD
AND ASSEMBLING THE MAIN BODY
OF THE AIRCRAFT**

STAGE 65: SLIDER ASSEMBLY

**STAGE 66: ASSEMBLING THE DISPLAY
PEDESTAL LIFTING DEVICE**

**STAGE 67: ASSEMBLING THE GEARBOX
FOR THE LIFTING DEVICE**

**STAGE 68: ATTACHING THE UNDERSIDE
PANEL OF THE LEFT WING**

**STAGE 69: ASSEMBLING THE LIMIT SWITCH
AND DISPLAY PEDESTAL**

**STAGE 70: ATTACHING THE UNDERSIDE
PANEL OF THE RIGHT WING**



There are excellent videos showing how to build the Zero [here](#).

Advice from the experts

Spare screws are included with each part. Occasionally, you may be instructed to keep spare or unused screws for a later stage.

Keep these spares in a safe place and label them correctly.

Please make sure you don't mix up the screws. They look quite similar, but the threads do vary slightly. Using the wrong screws may damage the parts.

When securing parts together using multiple screws, fit each screw loosely to ensure all the parts are correctly aligned before gently tightening them firmly, but not overtight, in the order in which you placed them.

The screwdriver can be magnetised by stroking it with a magnet (fridge magnet, etc.) enabling it to hold the screws and make assembly easier.

If a screw is tight going into a metal part, do not force it as you may shear the head off. Remove it and put a tiny smear of Vaseline, soap or light oil on the thread. That will lubricate it and make it easier to drive home.

During the course of this build, you will receive many pieces that you will assemble immediately – following the instructions in the corresponding stage – and other pieces that you should store safely to one side, for use in future assembly stages.

When gluing parts together, glue may be applied to either of the two parts. Some experts find it easier to apply glue to a hole rather than a pin. Choose a method that works best for you.

It's a good idea to test fit your parts so that you can check their positioning before gluing.

Not suitable for children under the age of 14. This product is not a toy and is not designed for use in play. Keep the parts out of the reach of small children. Some parts may have sharp edges. Please handle them with care.

Stage 62: Elevator Assembly

In this stage we'll assemble the left elevator and then, along with the right elevator from Stage 59, install these in the main frame of the aircraft. We'll also connect the elevators to a servomotor with a rod.



Stage 62 Assembly

Elevator (Left)

STAGE 62 PARTS

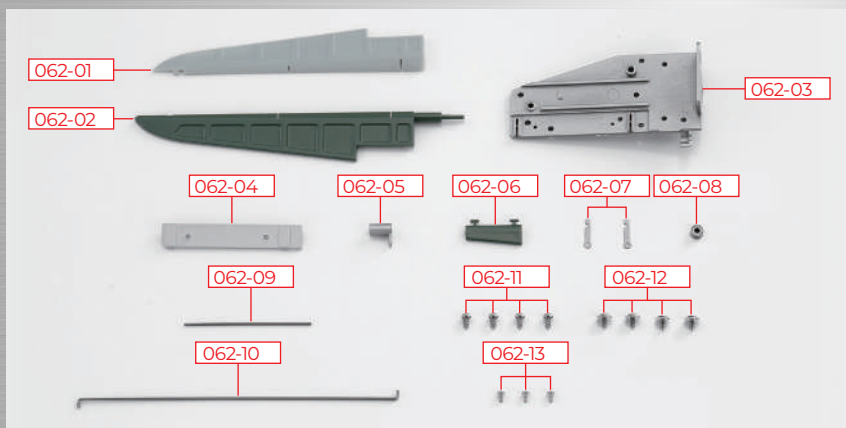

You will also need: screwdriver, superglue
 * Parts may differ from those shown but this will not affect assembly.

PARTS LIST

	PART	No.	MATERIAL
<input type="checkbox"/>	062-01	1	ABS resin
<input type="checkbox"/>	062-02	1	ABS resin
<input type="checkbox"/>	062-03	1	ABS resin
<input type="checkbox"/>	062-04	1	ABS resin
<input type="checkbox"/>	062-05	1	ABS resin
<input type="checkbox"/>	062-06	1	ABS resin
<input type="checkbox"/>	062-07	2	Steel
<input type="checkbox"/>	062-08	1	Steel
<input type="checkbox"/>	062-09	1	Steel
<input type="checkbox"/>	062-10	1	Steel
<input type="checkbox"/>	062-11	4 (1 spare)	Steel
<input type="checkbox"/>	062-12	4 (1 spare)	Steel
<input type="checkbox"/>	062-13	3 (1 spare)	Steel

STEP 1

Assembling the elevator (L)

← : Glue
 ← : Don't Glue

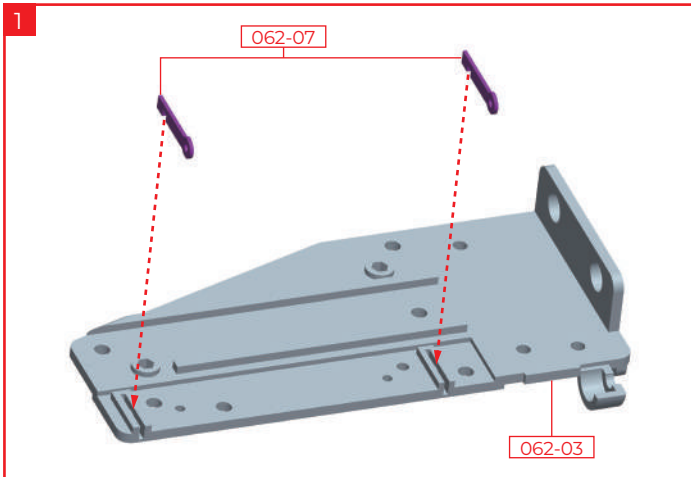

Fit the two hinges 062-07 into the frame 062-03 with the notches facing down.

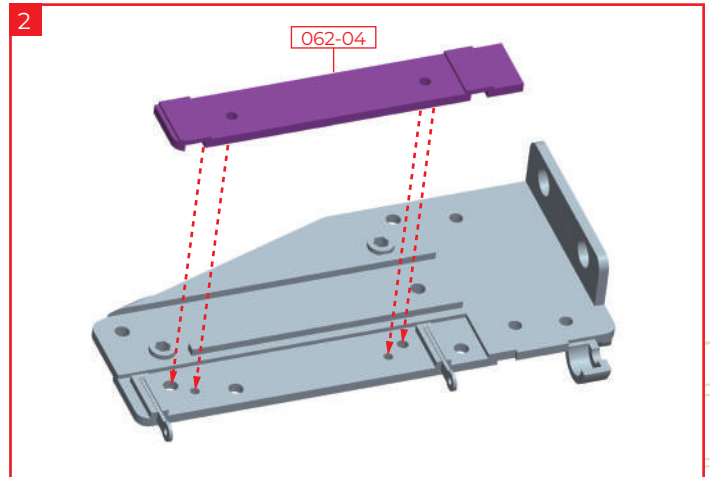

Align the screw holes, protrusions, and holes on the frame 062-03 and the hinge cover 062-04 and fit them together.

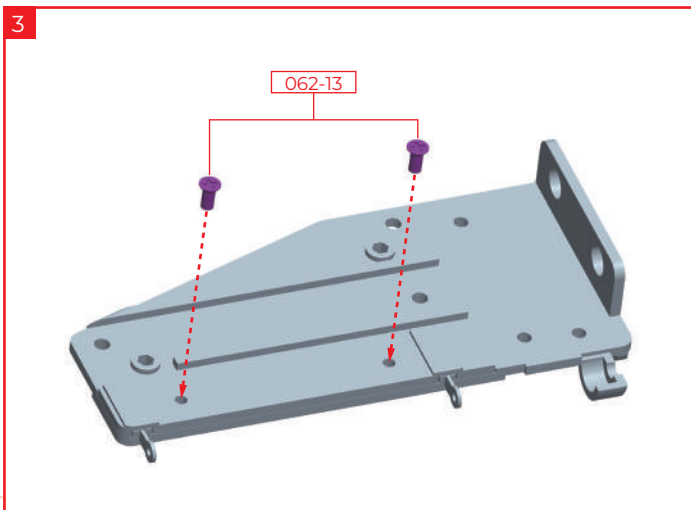

Fix the hinge cover 062-04 in place using 2 x screws 062-13.

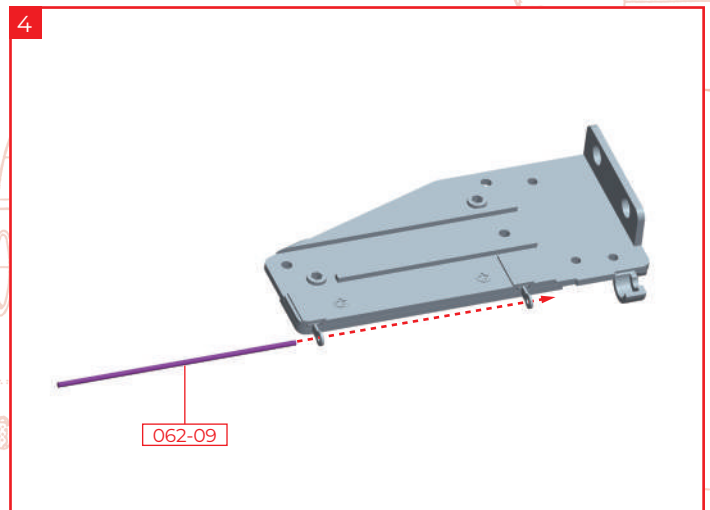

Thread the shaft 062-09 through the two holes on the hinge 062-07.

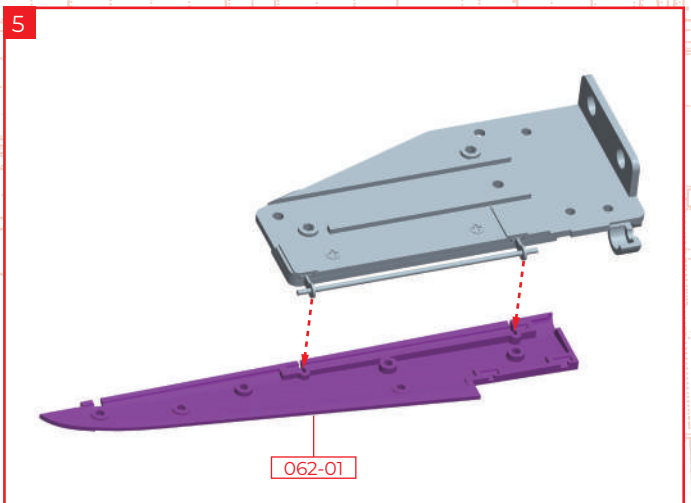

Fit two hinges 062-07 and shaft 062-09 into the groove on the lower surface 062-01 of the elevator (left).

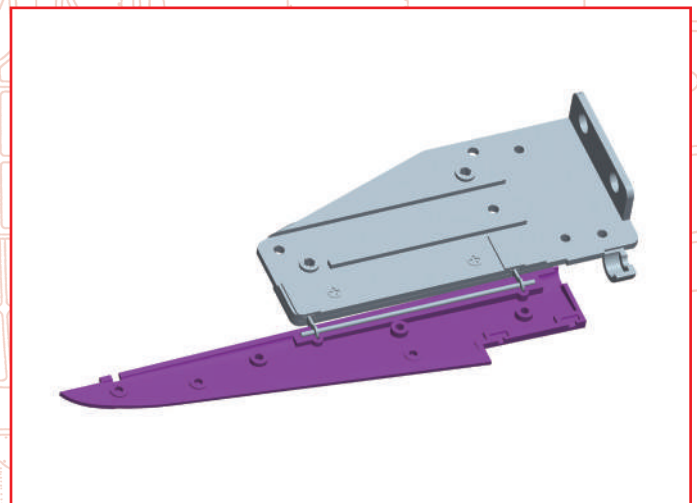

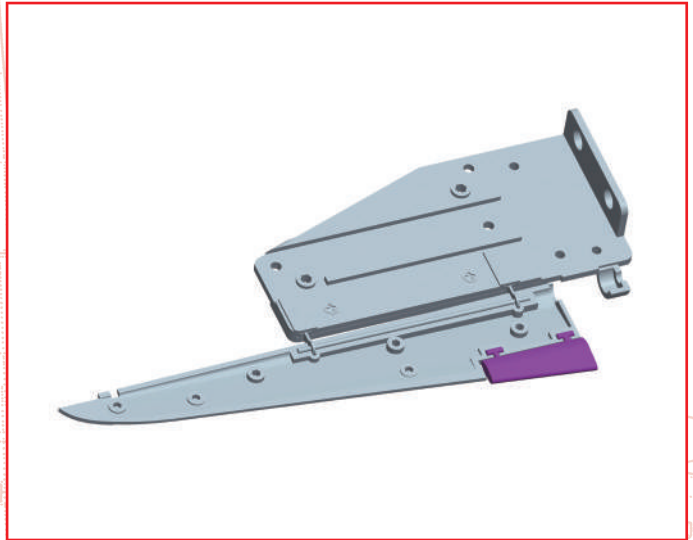
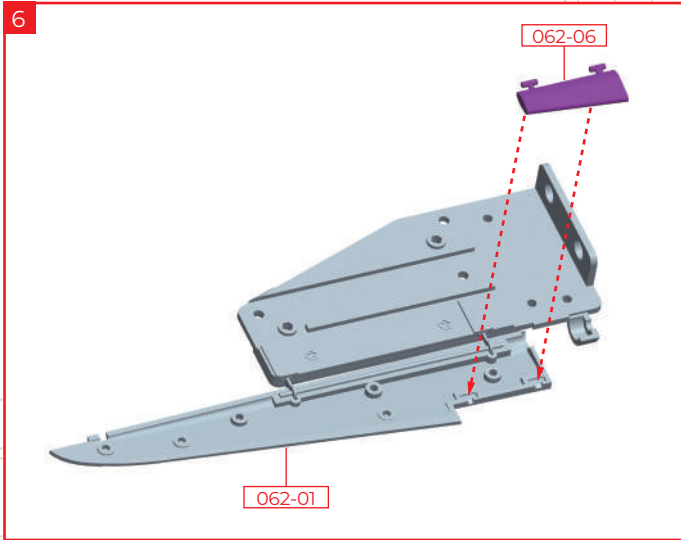

Fit the hinge of the elevator trim tab 062-06 onto the lower surface 062-01 of the elevator (left).

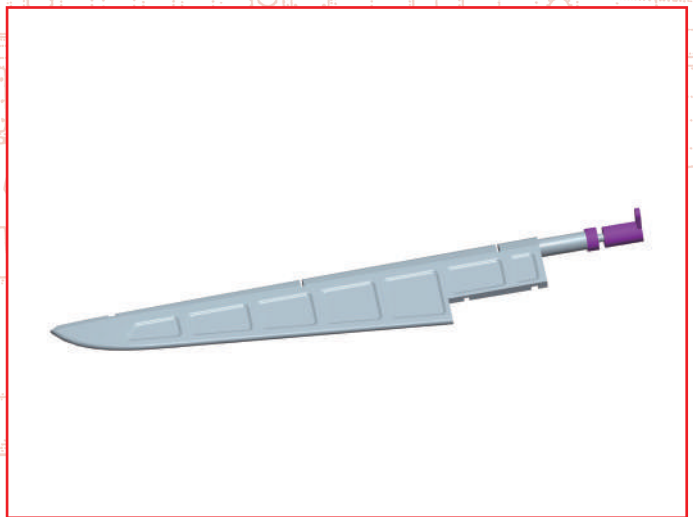
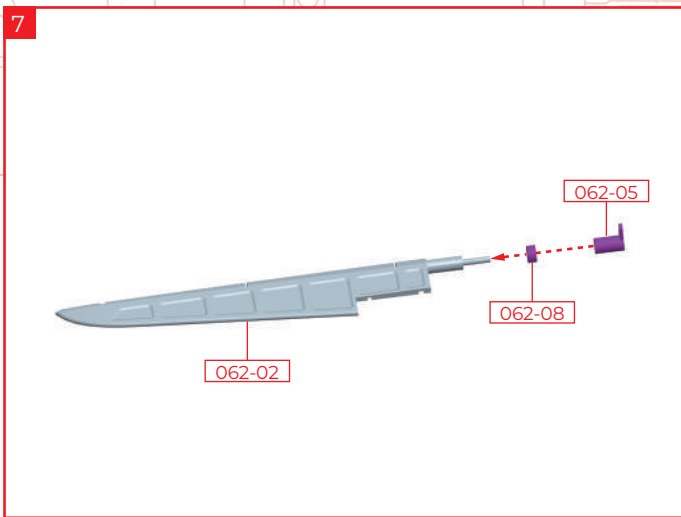

Fit the bearing 062-08 and arm 062-05 on the shaft of the elevator (left) upper surface 062-02. This is a D-shaped fixing to ensure the correct fit.

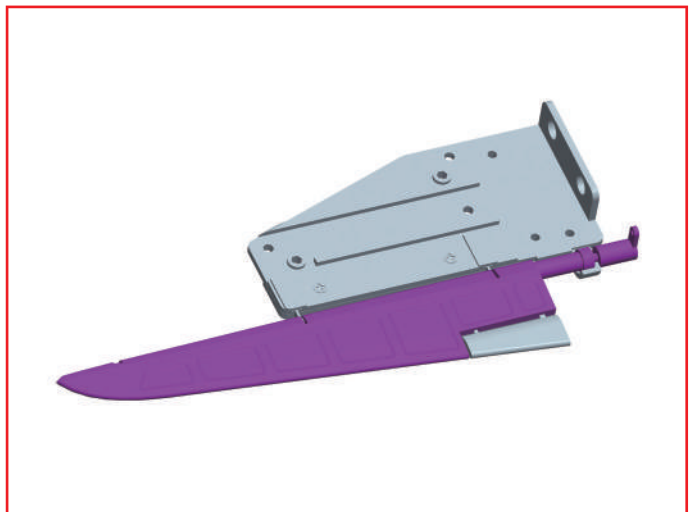
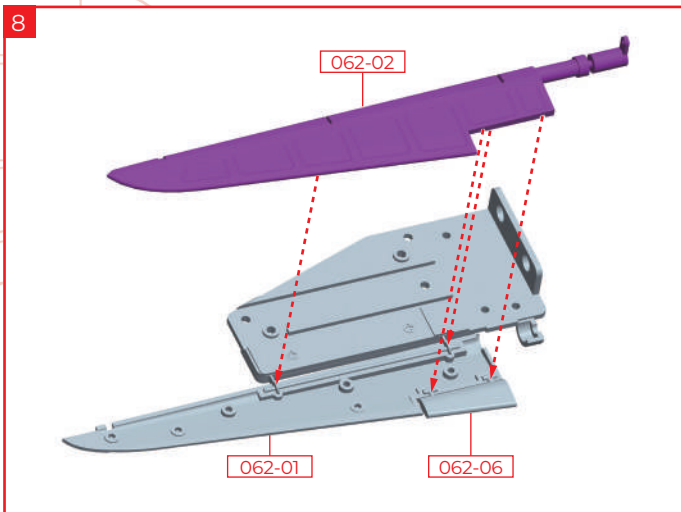

Fit the elevator (left) lower surface 062-01 of the unit assembled in 6 and the elevator (left) upper surface 062-02 assembled in 7. If the fit is loose, use a small amount of superglue on the 6 protrusions and holes on the top and bottom.

STEP 2 Installing the elevators

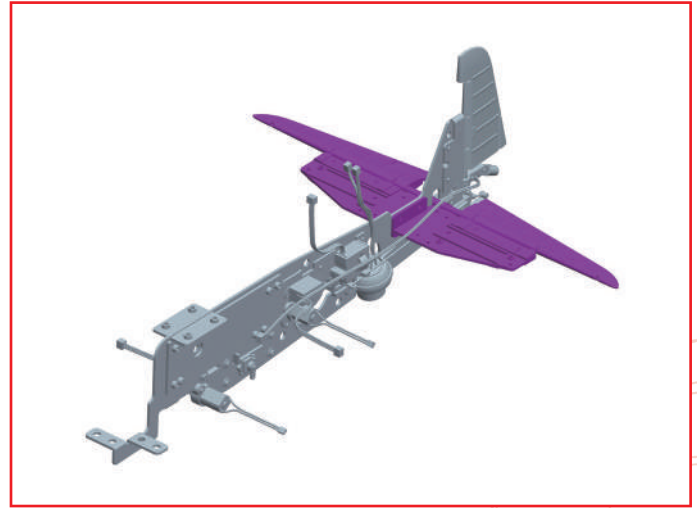
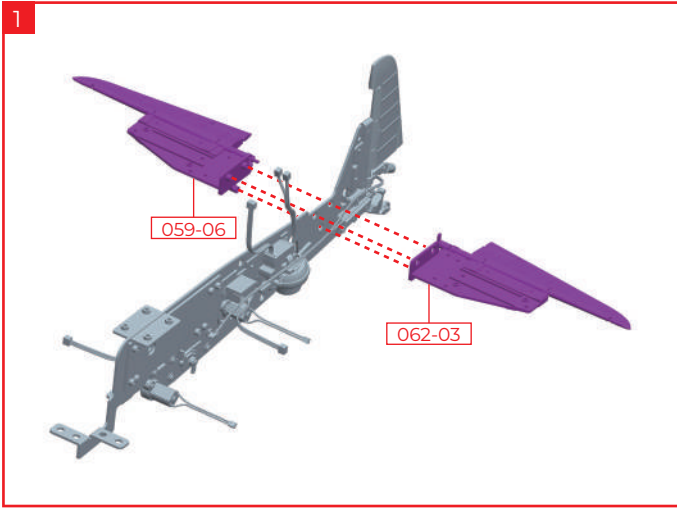

Align the protrusions and holes of the elevator (right) assembled in stage 59 and the elevator (left) assembled in STEP 1 into the fuselage frame.

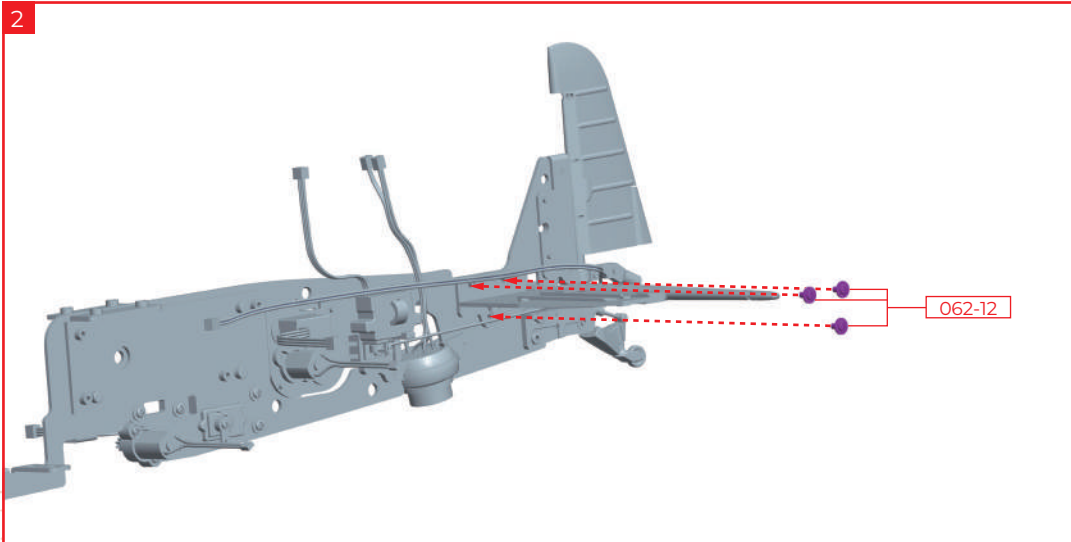

Fix the elevator (left) frame 062-03 and the elevator (right) frame 059-06 with 3 x screws 062-12.

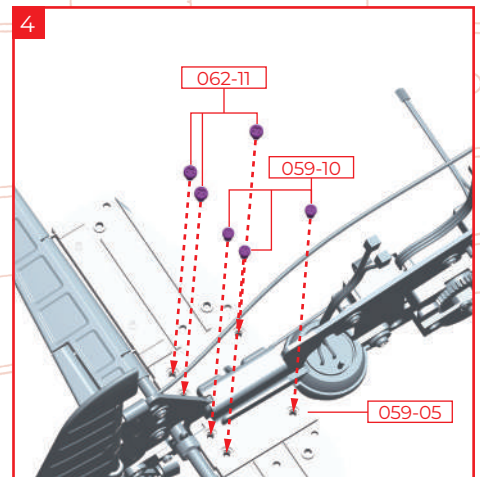
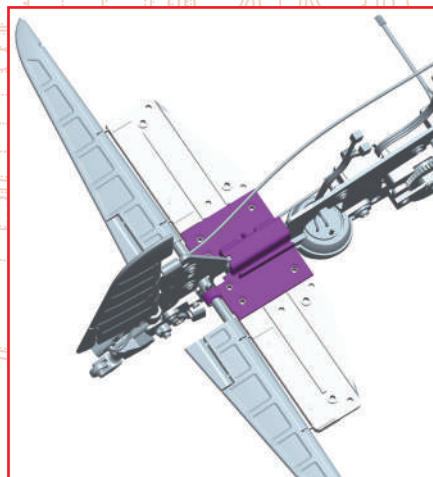
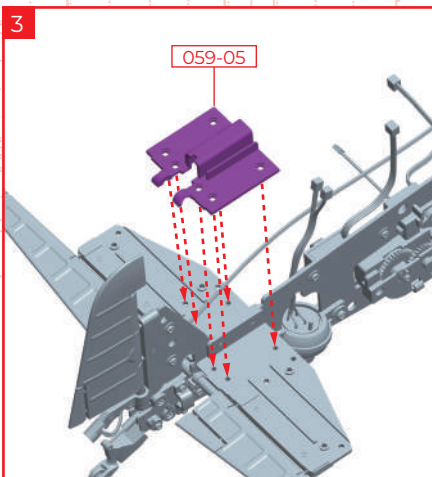

Carefully lower the frame 059-05 that came with stage 59 over the elevator.

Fix the frame with 3 x screws 062-11 and 3 x screws 059-10 that came with stage 59.

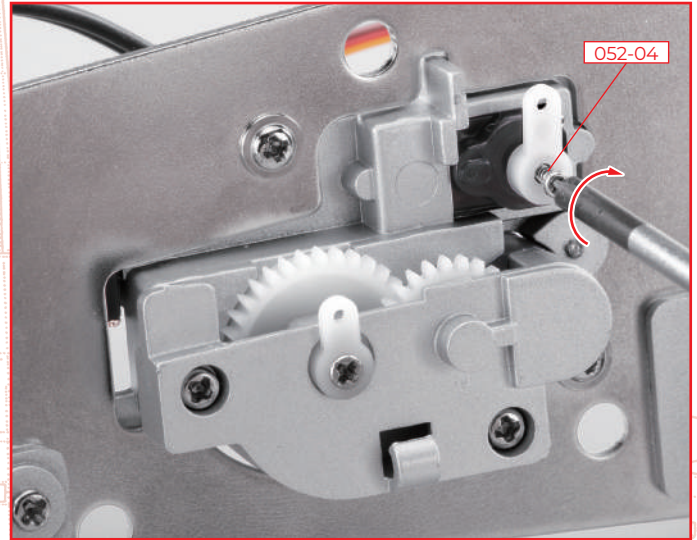
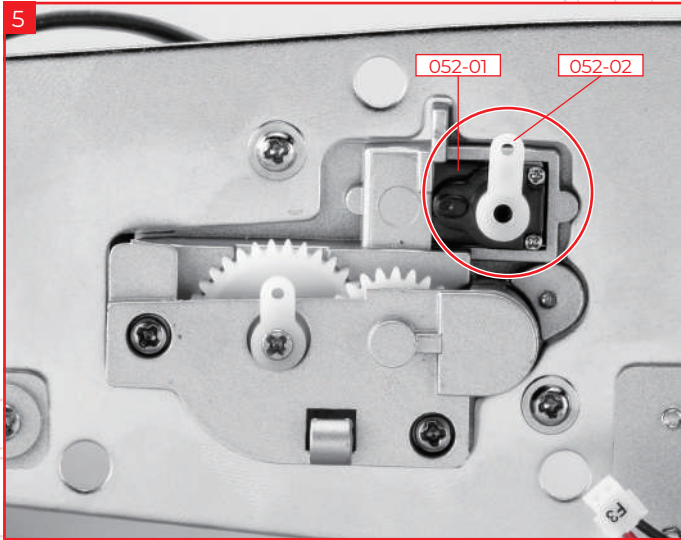

Insert the arm 052-02 from stage 52 into the servomotor 052-01 that was attached to the gearbox in stage 59, in the direction shown in the photo, and fix it with screws 052-04.

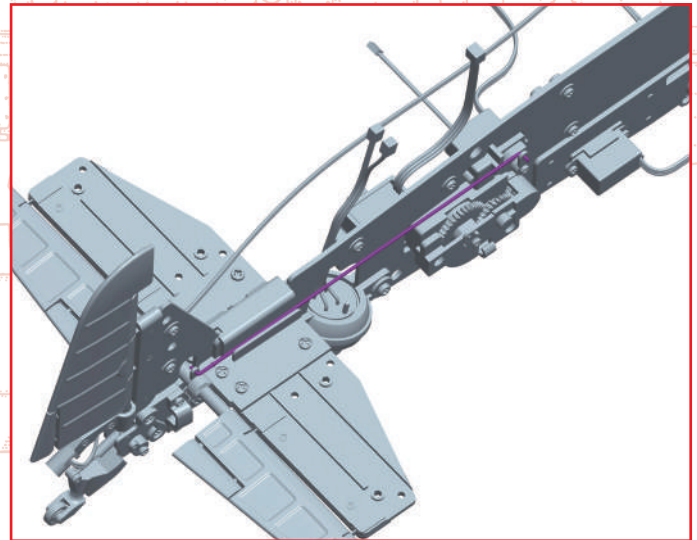
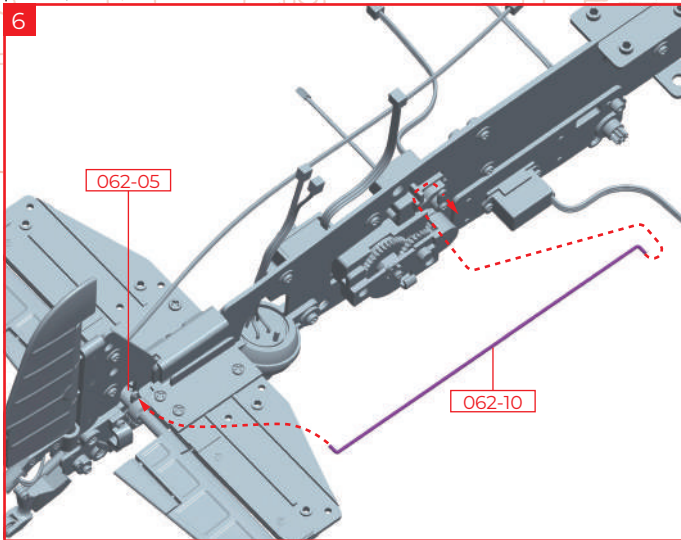

Insert the rod 062-10 into the arm 052-02 attached in step 5 and the arm 062-05 of the elevator (left).

STAGE COMPLETE

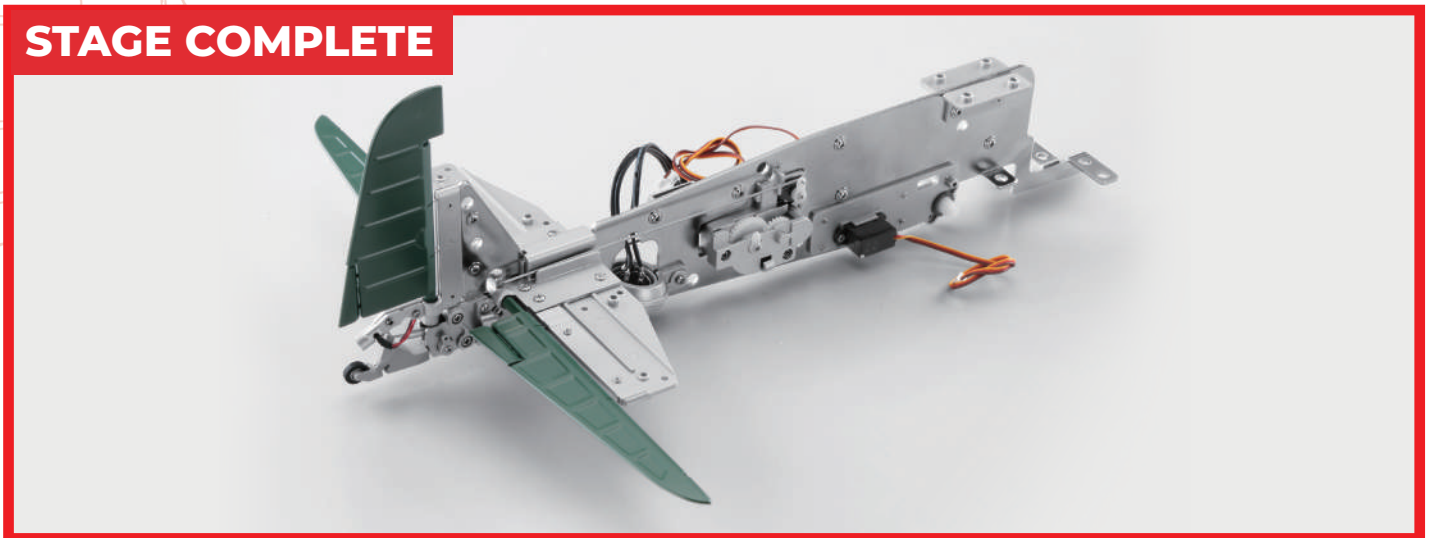

Stage 63: Display Pedestal Assembly

Stage 63 Assembly

Pedestal

In this stage we'll continue working on the frame for the display pedestal. Make sure the position of the bottom grooves line up properly and the part with the diagonal cut is in the right place to prevent any cracking appearing in future stages

STAGE 63 PARTS

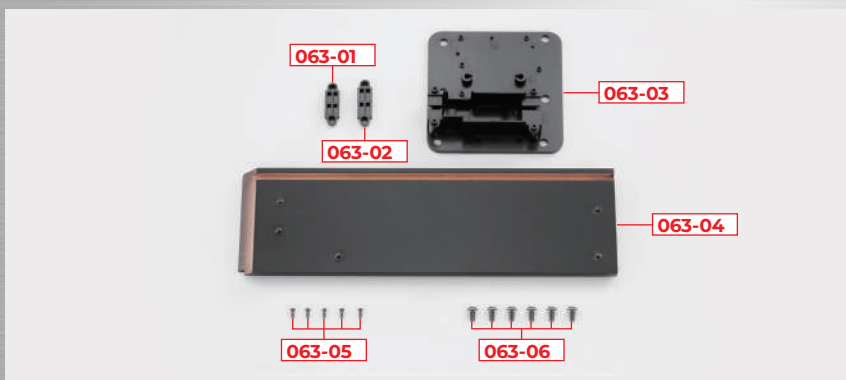

You will also need: screwdriver

* 063-01, 063-02, 063-03, 063-05, 063-06 will be used in a later stage.

*Parts may differ slightly from those shown but this will not affect assembly.

PARTS LIST

	PART	No.	MATERIAL
<input type="checkbox"/>	063-01	1	ABS resin
<input type="checkbox"/>	063-02	1	ABS resin
<input type="checkbox"/>	063-03	1	ABS resin
<input type="checkbox"/>	063-04	1	MDF
<input type="checkbox"/>	063-05	5 (1 spare)	Steel
<input type="checkbox"/>	063-06	6	Steel

STEP 1

Assembling the display pedestal

← : Glue
- - - : Don't Glue

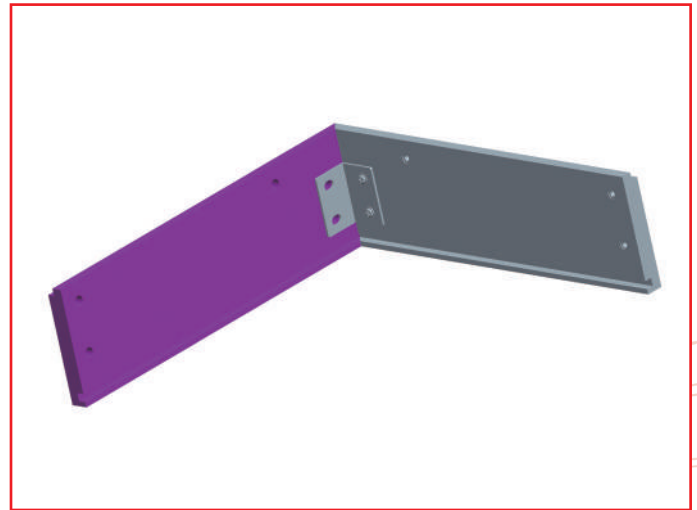
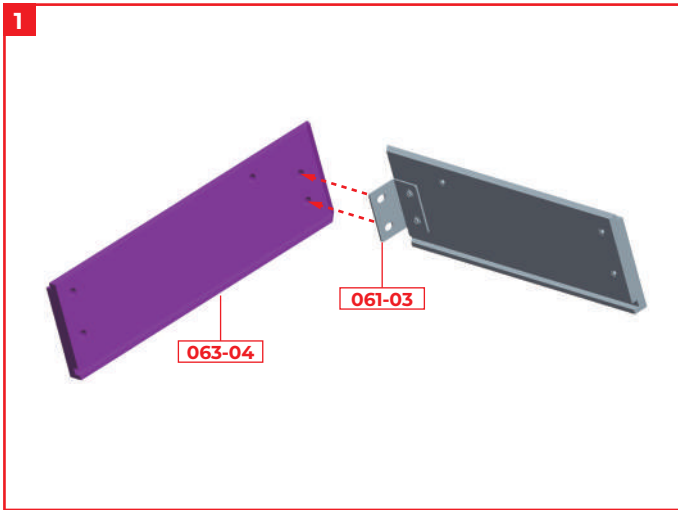

Align the holes in the pedestal frame 063-04 with the metal fittings 061-03 of the pedestal frame assembled in stage 61.

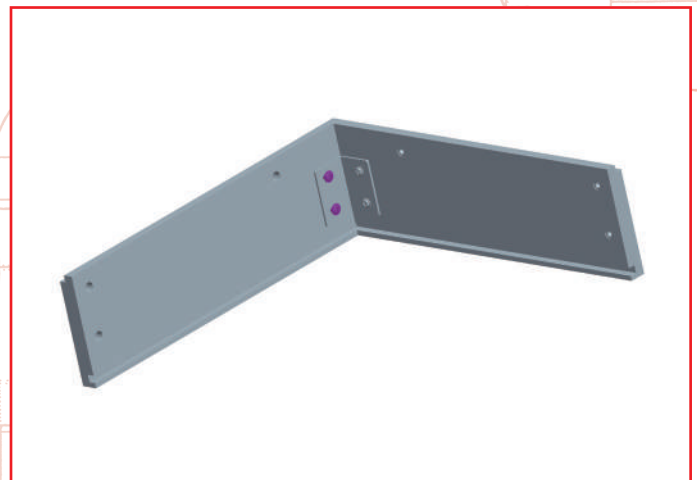
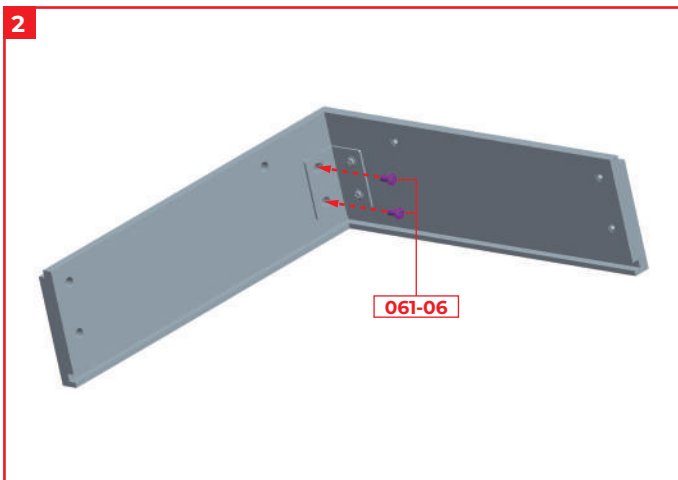

Fix the two parts together with 2 x 061-06 screws from stage 61. When tightening the screws, adjust them so that the corners of the pedestal frame do not shift, and tighten them little by little.

STAGE COMPLETE

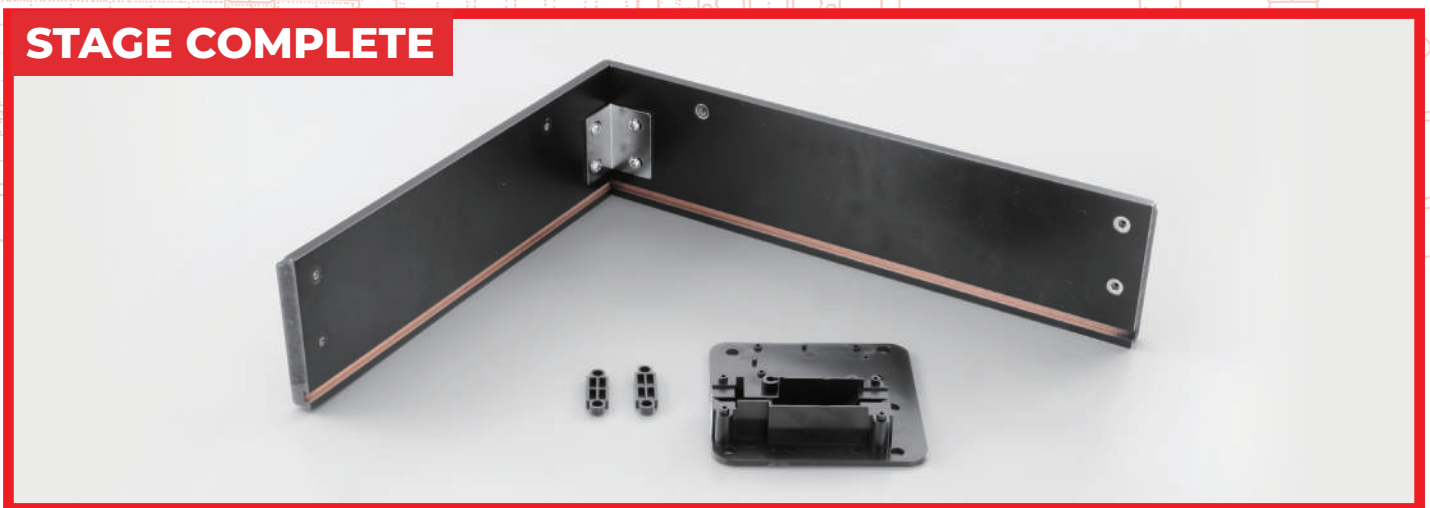

Stage 64: Installing the Circuit Board and Assembling the Main Body of the Aircraft



Stage 64 Assembly

Circuit Board

In this stage we'll be installing a circuit board into the fuselage frame and connecting various lights and moving parts to their respective motors.

STAGE 64 PARTS

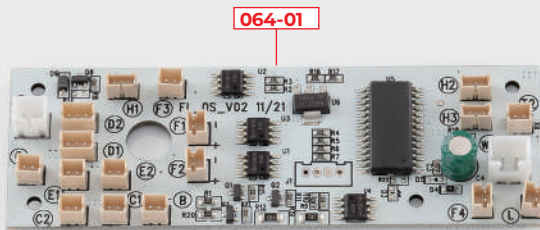

You will also need: screwdriver

* Parts may differ slightly from those shown but this will not affect assembly.

PARTS LIST

	PART	No.	MATERIAL
<input type="checkbox"/>	064-01	1	Circuit board
<input type="checkbox"/>	064-02	5 (1 spare)	Steel

STEP 1

Installing the circuit board

← : Glue
- - - : Don't Glue

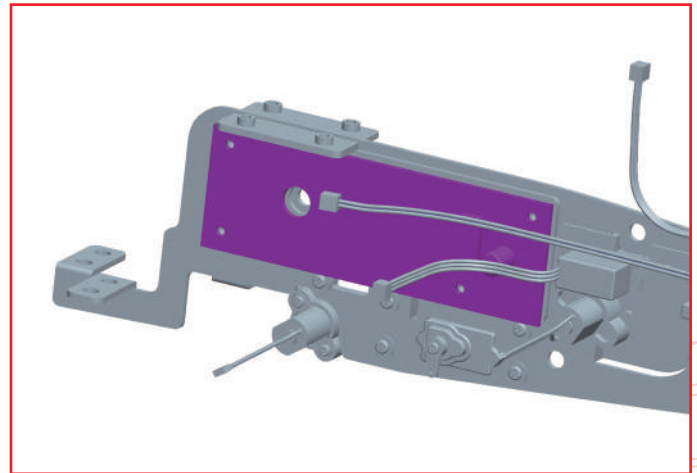
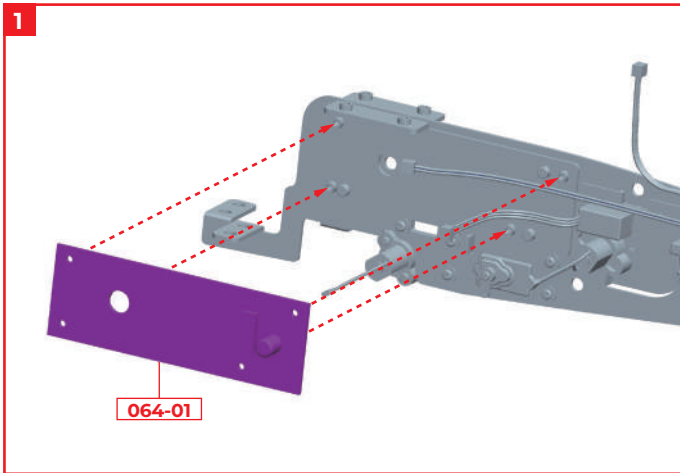

Align the circuit board 064-01 with the aircraft frame.

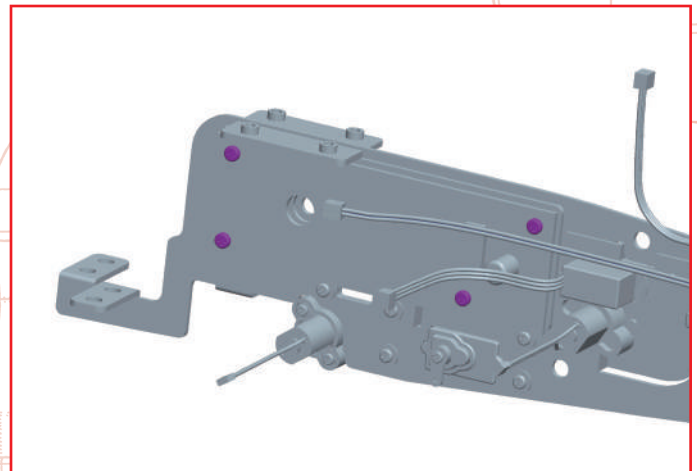
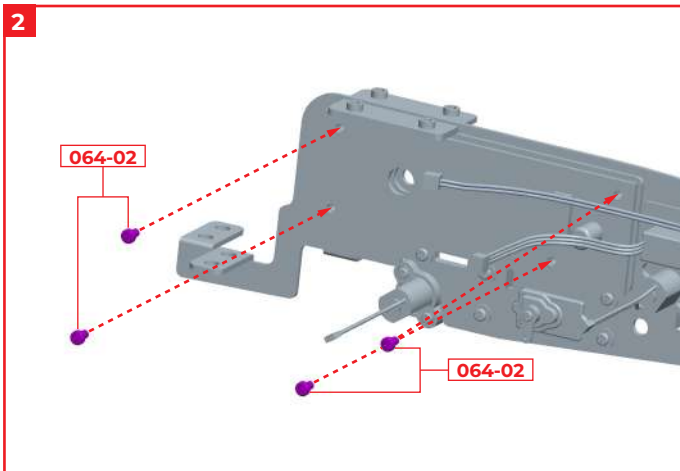

Fix the circuit board in place with 4 x screws 064-02.

STEP 2

Combining the wings and fuselage

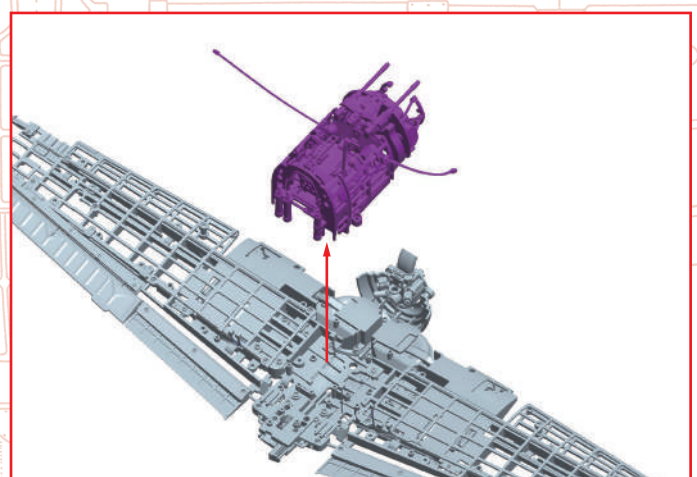
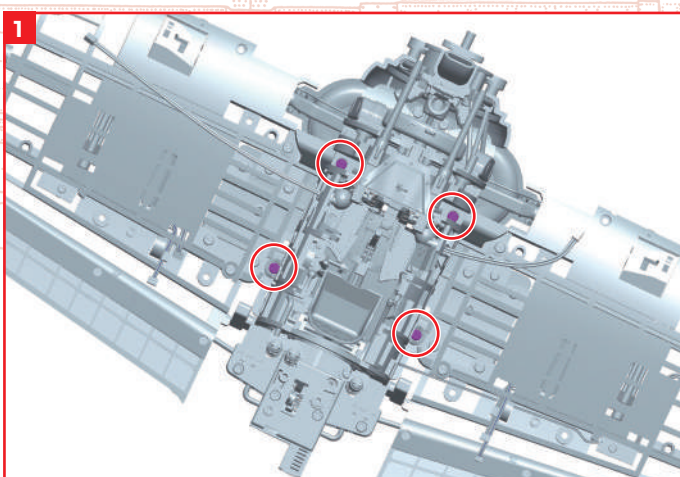

Remove the four screws 049-03 that secure the cockpit to the main wing, attached in stage 49, and keep them in a safe place. Then remove the cockpit.

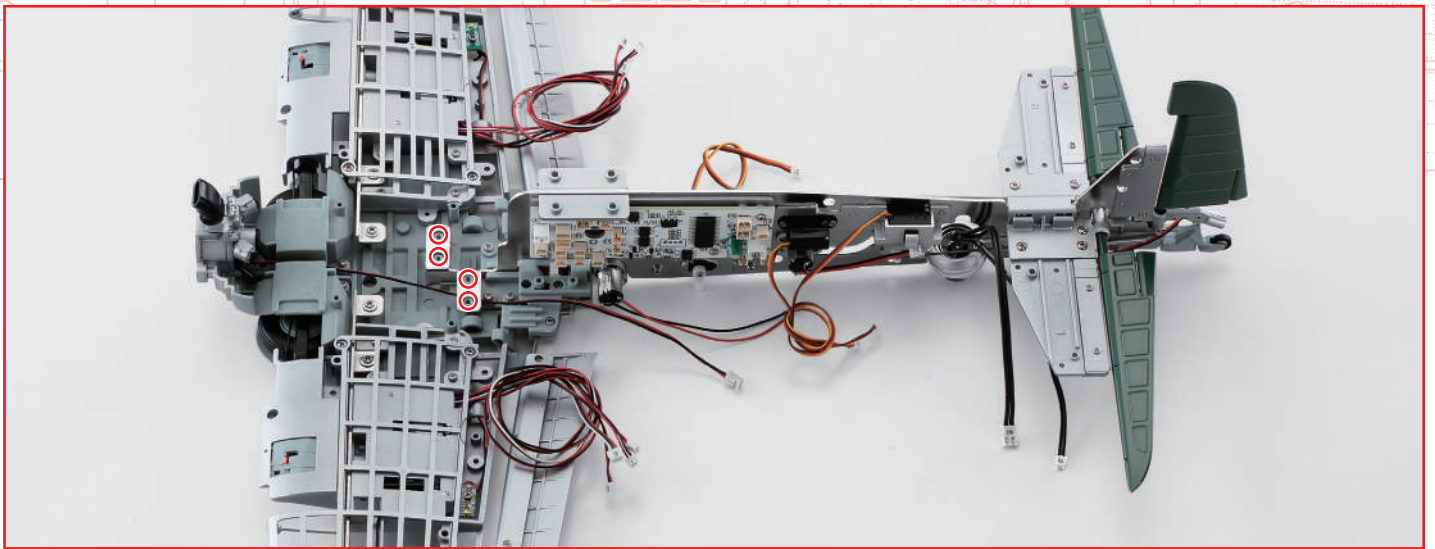
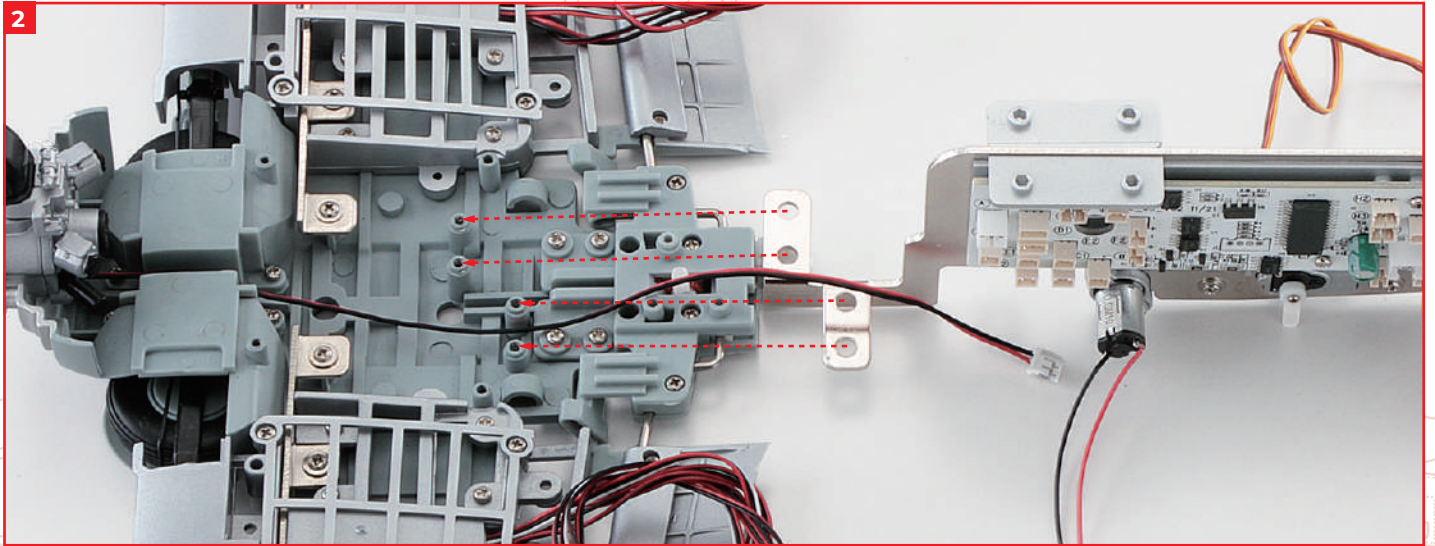

Align the holes at the tip of the fuselage frame with the four holes on the main wing.

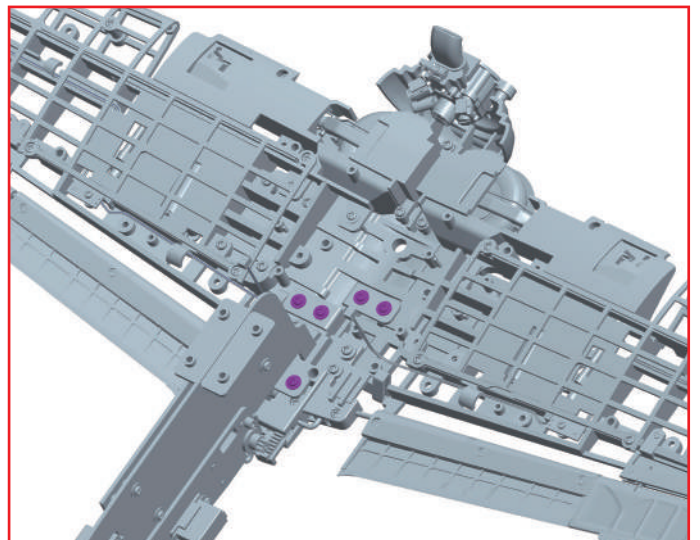
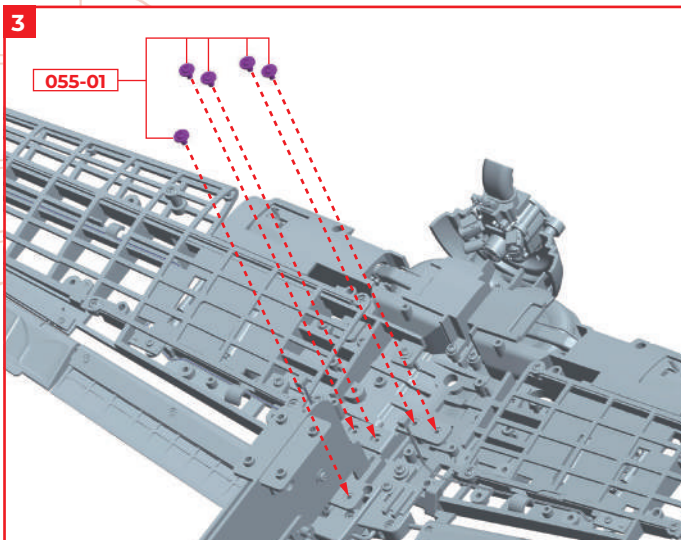

Fix the fuselage frame in place with 5 x screws 055-01 that came in stage 55.

STEP 3 Connecting up the wires to the circuit board

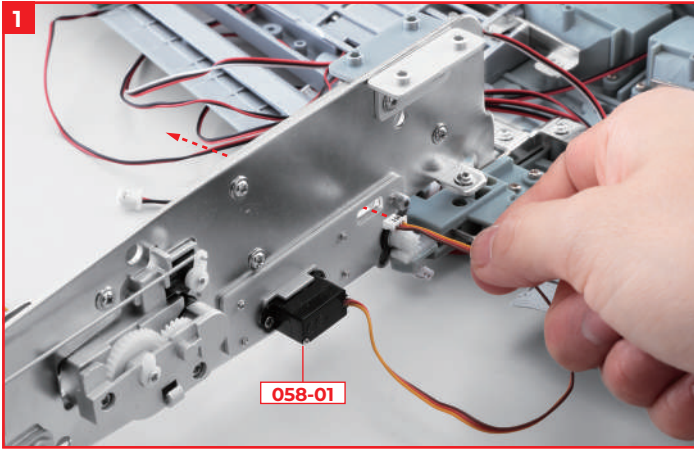

Pass the servomotor wire **058-01** on the right side of the fuselage frame through the square hole and pull it out on the left side of the fuselage.

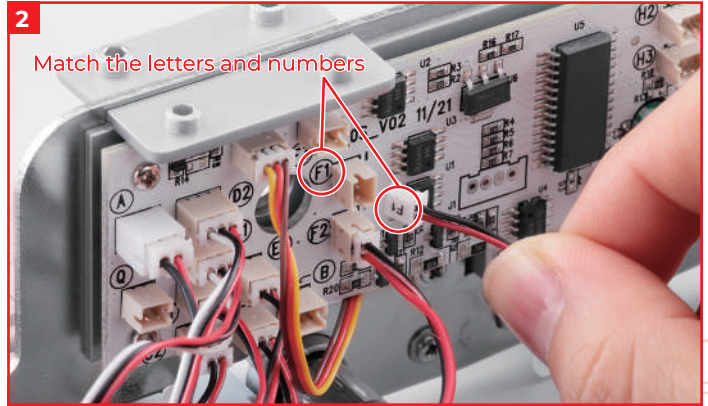

Insert the wires extending from the fuselage frame and main wing into the connectors on circuit board **064-01**. Match the alphanumeric characters written on the circuit board with the characters written on each wire.

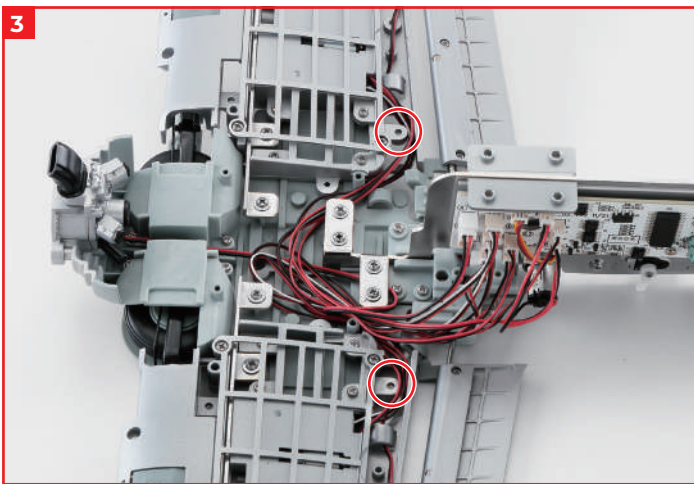

Bunch the wires as shown in the picture, ensuring that they run around the holes circled in red.

NOTE

There are indentations on both sides of the circuit board connectors which correspond to the indentations on the tip of the wire to ensure that they can only be connected the right way round.

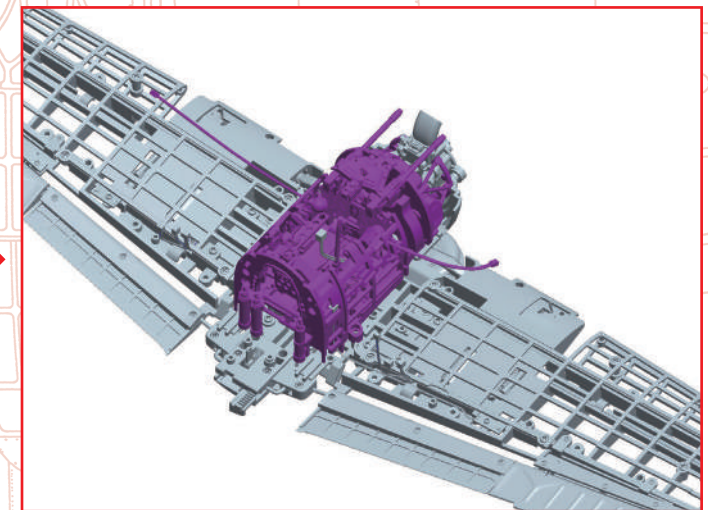
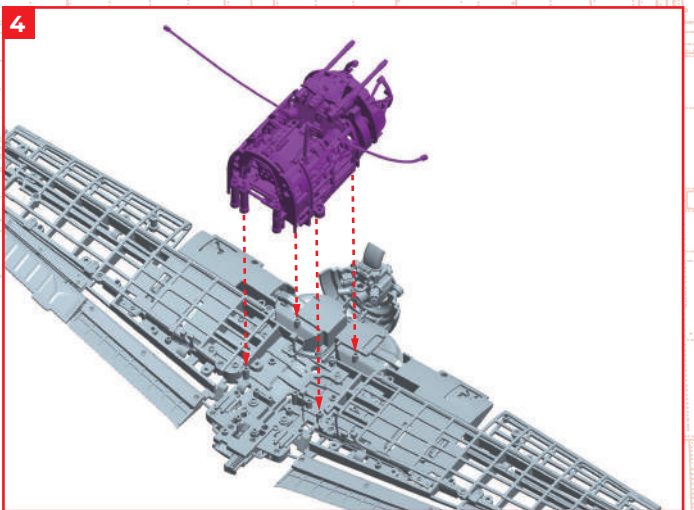

Re-attach the cockpit removed in STEP 2 into the main wing as before. Refer back to STEP 3 of stage 49 for guidance if necessary.

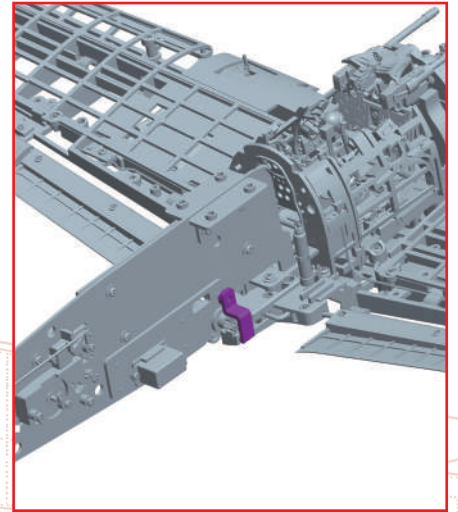
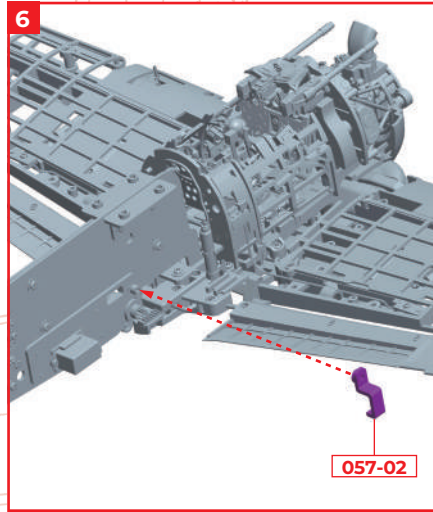
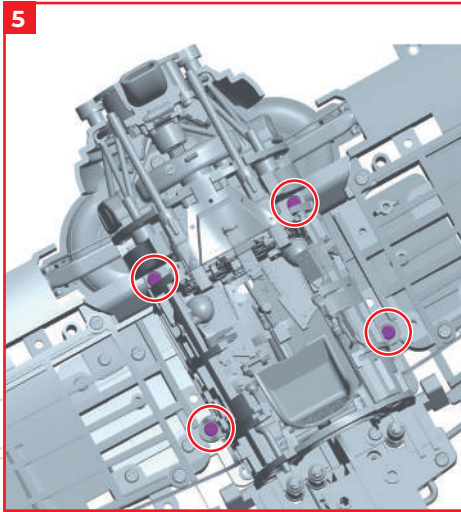

Fix the cockpit with 4 x screws 049-03 that were removed in STEP 2. Fit the gear cover 057-02 that came with stage 57 into the fuselage frame.

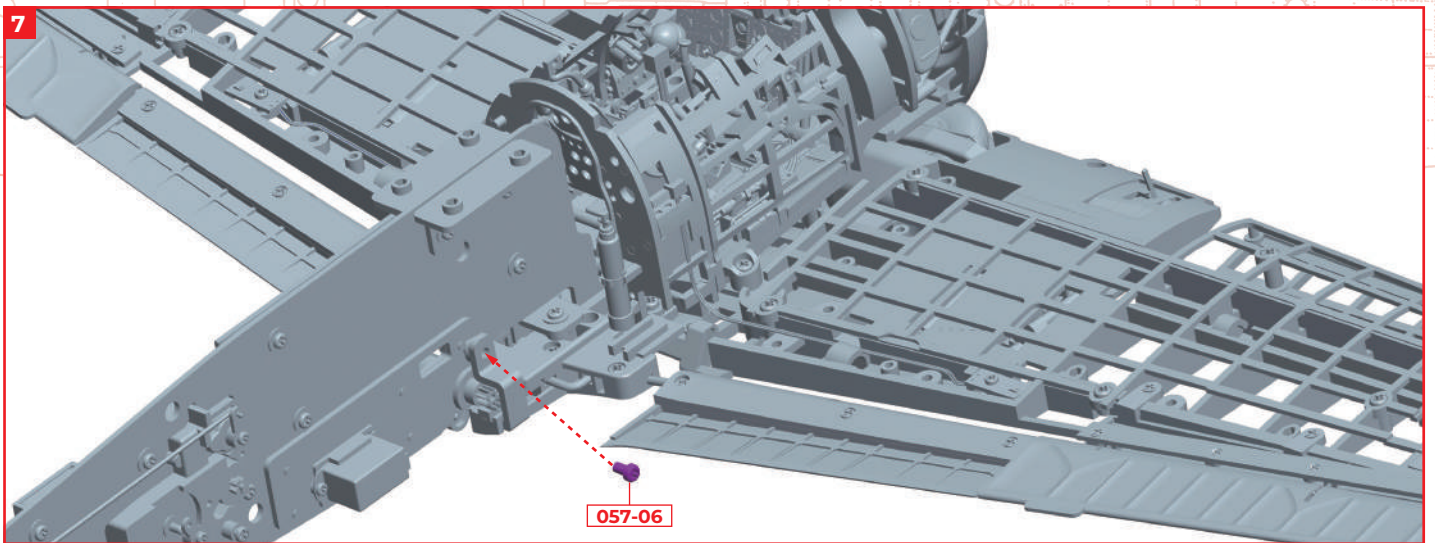

Fix the gear cover 057-02 in place with the screw 057-06 that came with stage 57.

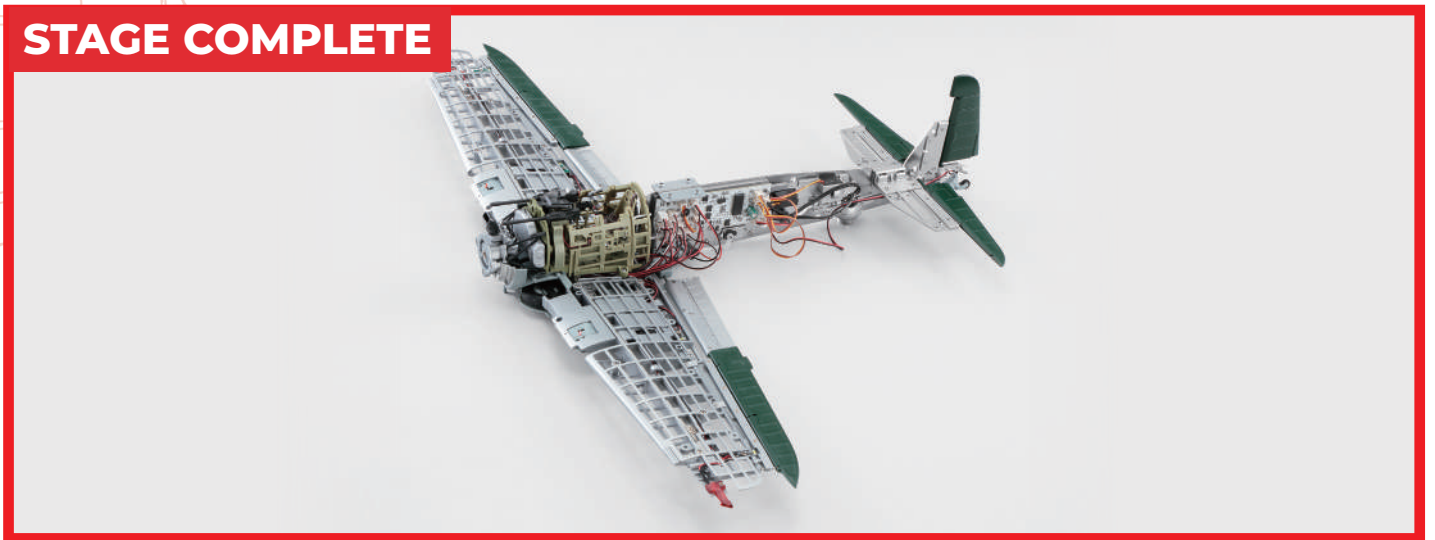

STAGE COMPLETE

Stage 65: Slider Assembly

In this stage we'll be assembling the slider for the lifting device installed inside the display pedestal. This is a key component in being able to use the remote control to tilt the A6M Zero in all directions later on.

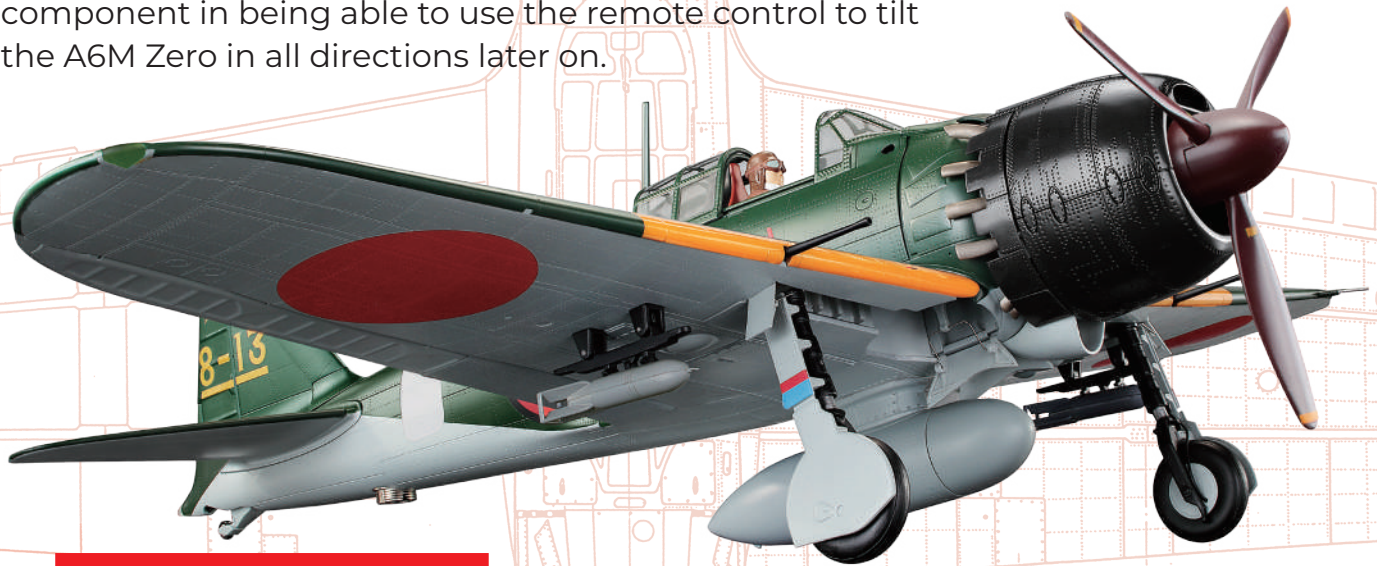

Stage 65 Assembly

Slider

STAGE 65 PARTS

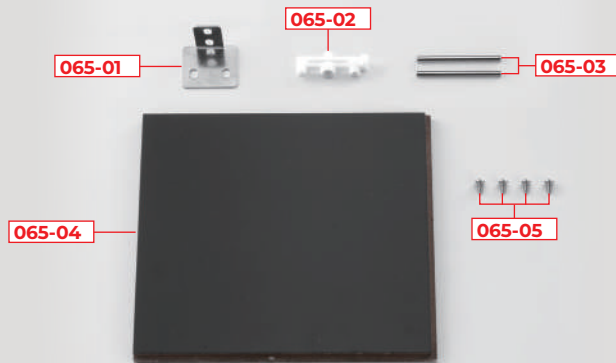

* Keep **065-01**, **065-04** & **065-05** in a safe place until they are used in a later stage

*Parts may differ slightly from those shown but this will not affect assembly.

PARTS LIST

	PART	No.	MATERIAL
<input type="checkbox"/>	065-01	1	Steel
<input type="checkbox"/>	065-02	1	Plastic
<input type="checkbox"/>	065-03	2	Steel
<input type="checkbox"/>	065-04	1	MDF
<input type="checkbox"/>	065-05	4	Steel

STEP 1

Slider assembly

← : Glue
- - - : Don't Glue

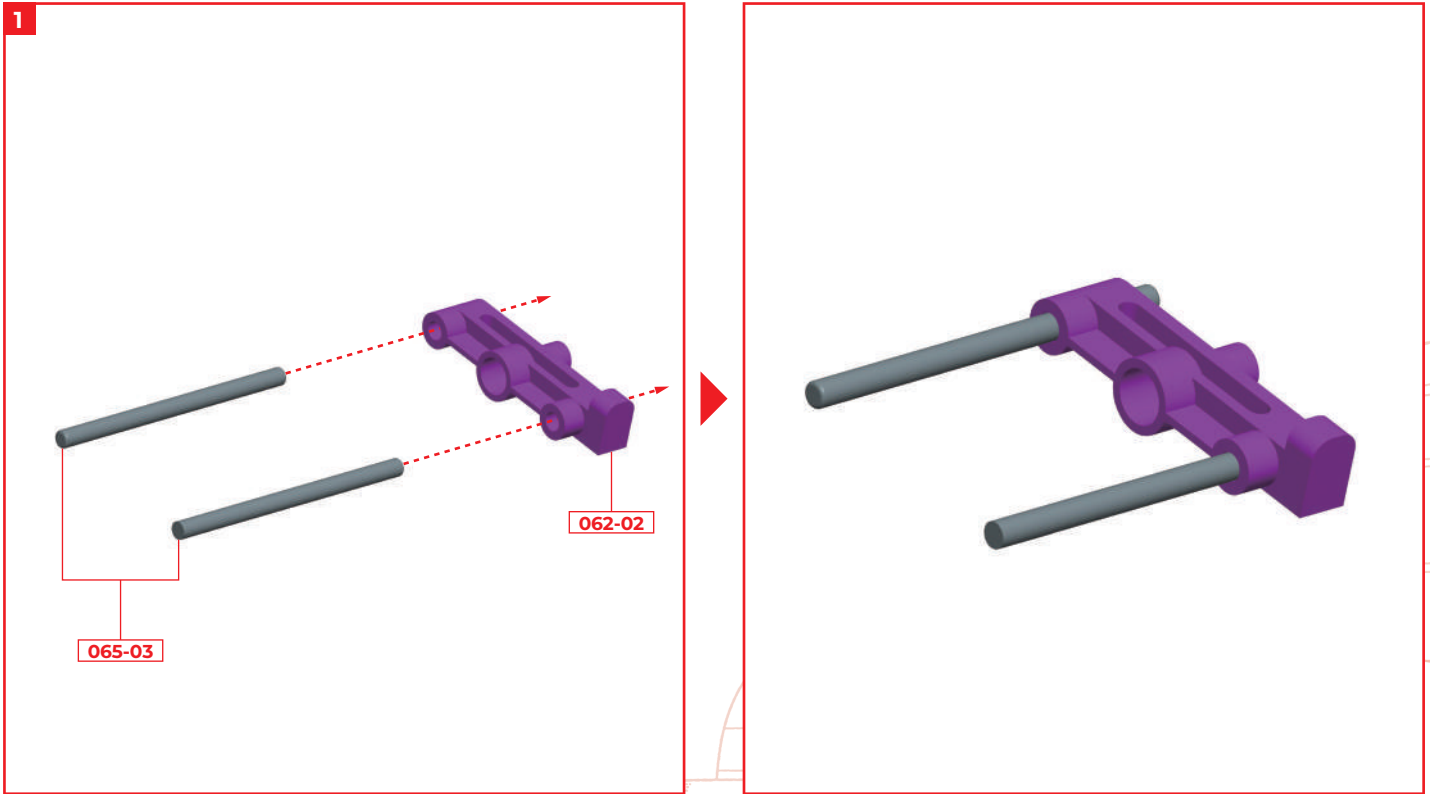

Insert the two shafts 065-03 into slider 065-02. It may help to gently file any flash off the metal tips to ensure a good fit.

STAGE COMPLETE



Stage 66: Assembling the Display Pedestal Lifting Device

In this stage we'll be assembling the lift and tilt device located inside the pedestal.

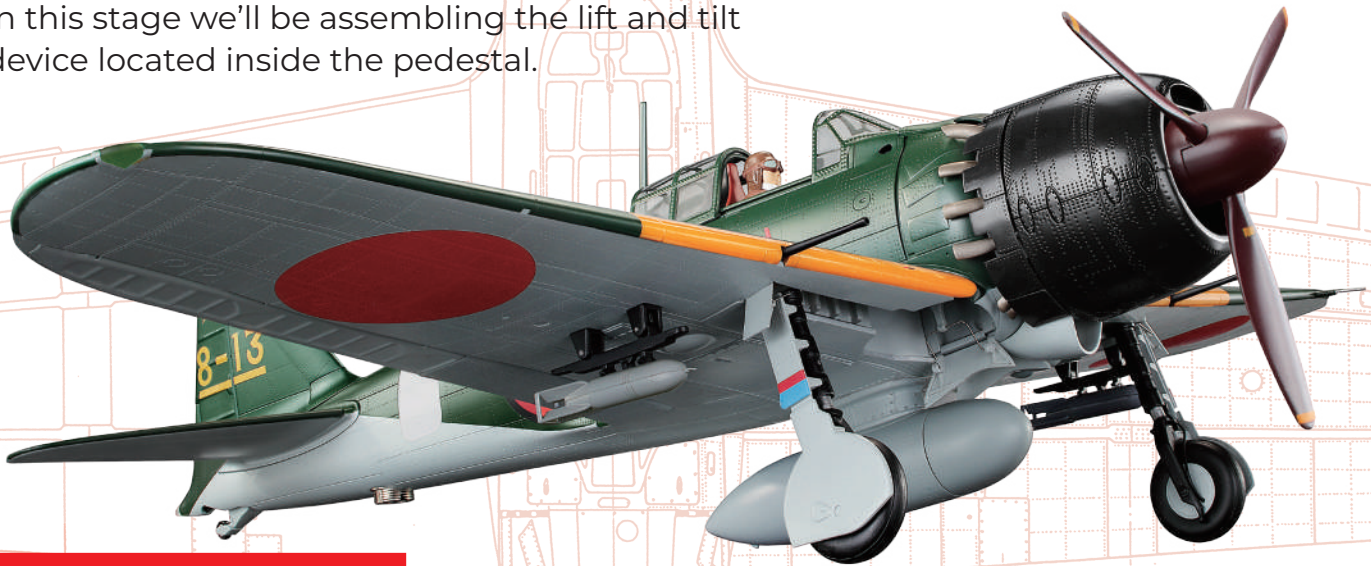

Stage 66 Assembly
 Aircraft Lifting Device

STAGE 66 PARTS

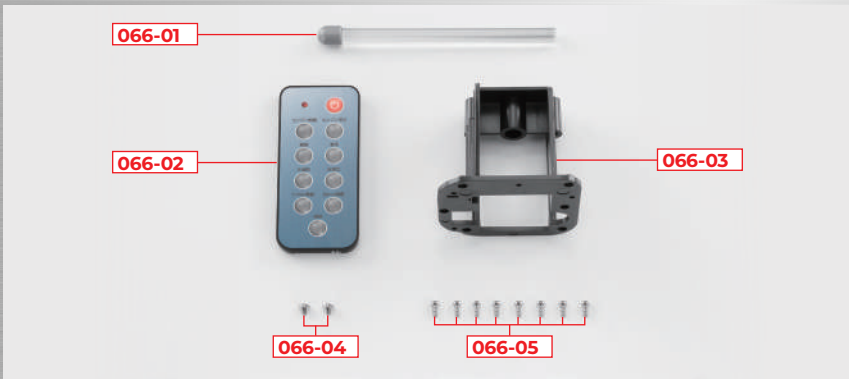

You will also need: screwdriver
 *066-02 & 066-04 are not used in this stage. Keep them safe until required.
 *Parts may differ slightly from those shown but this will not affect assembly.

PARTS LIST

	PART	No.	MATERIAL
<input type="checkbox"/>	066-01	1	Acrylic
<input type="checkbox"/>	066-02	1	Remote control
<input type="checkbox"/>	066-03	1	ABS resin
<input type="checkbox"/>	066-04	2 (1 spare)	Steel
<input type="checkbox"/>	066-05	8 (1 spare)	Steel

STEP 1

Assembling the lifting device

← : Glue
 ← : Don't Glue

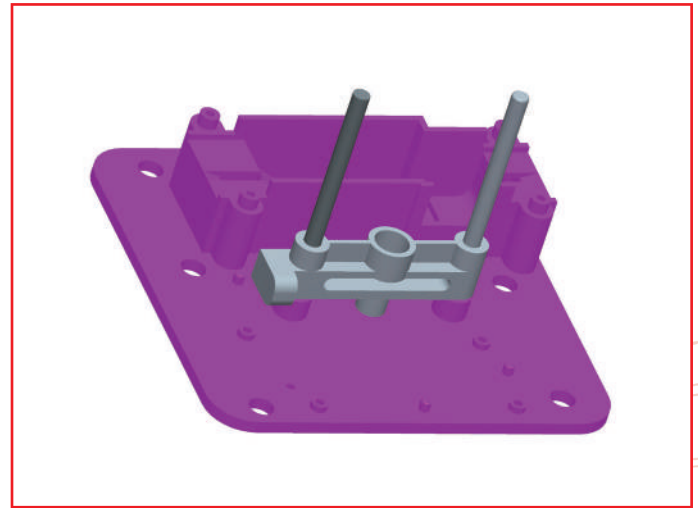
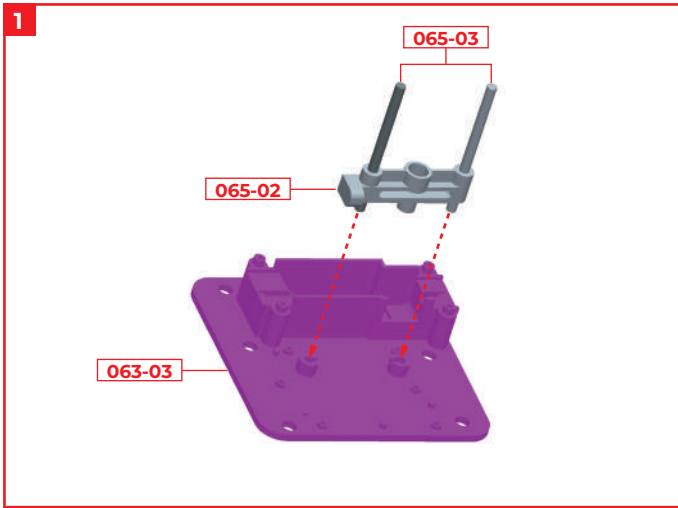

Insert the two slider shafts 065-03 assembled in stage 65 into the lifting device base 063-03 that came with stage 63.

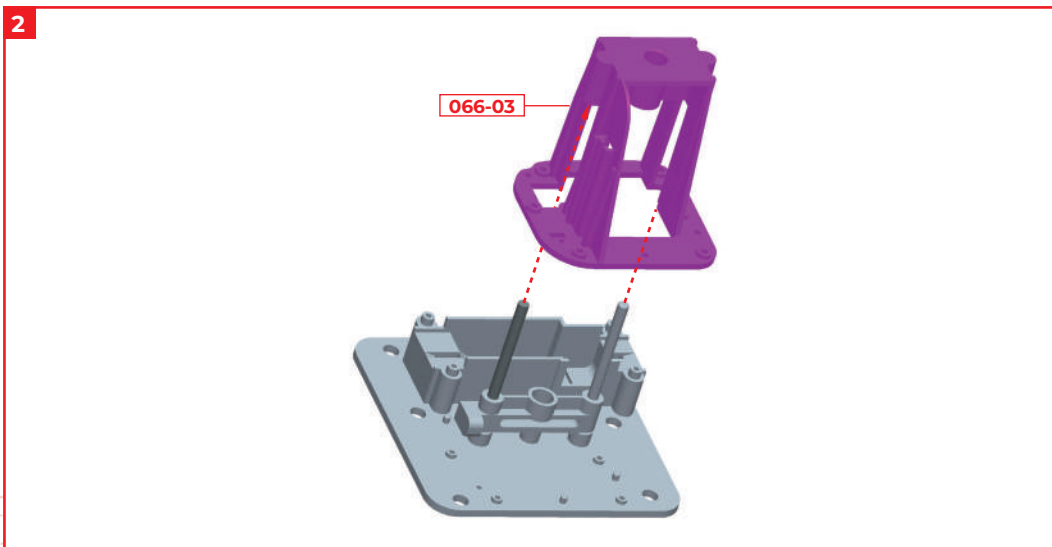

Insert the two shafts 065-03 into the lifting device frame 066-03.

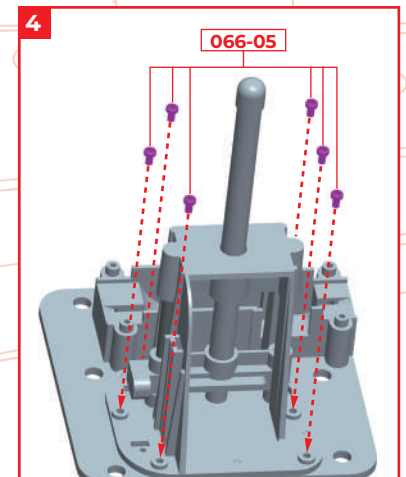
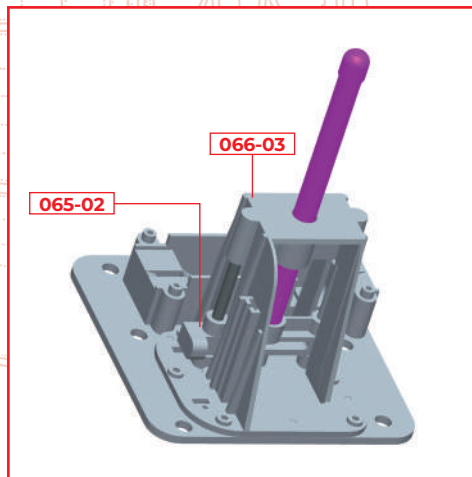
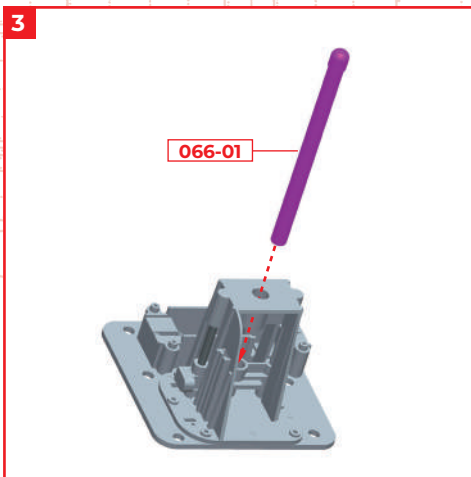

Insert the support bar 066-01 into the lifting device frame 066-03 through the hole at the top and anchor the tip of the support bar in the slider 065-02.

Fix the lifting device frame 066-03 in place using 6 x 066-05 screws.

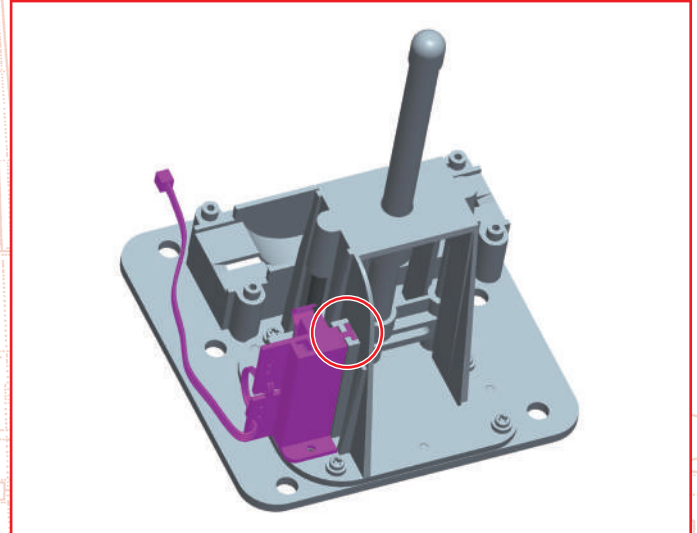
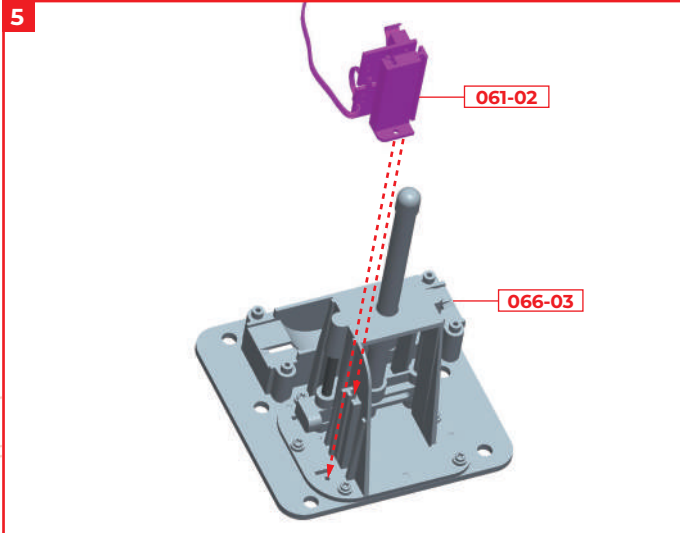

Slide the projecting 'T-shaped' part of the limit switch frame 061-02 assembled in stage 61 into the shaped groove in the lifting device frame 066-03 and fit it.

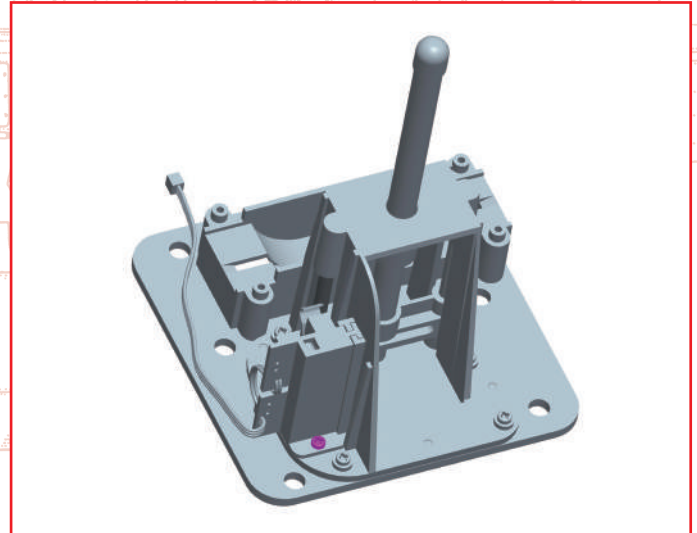
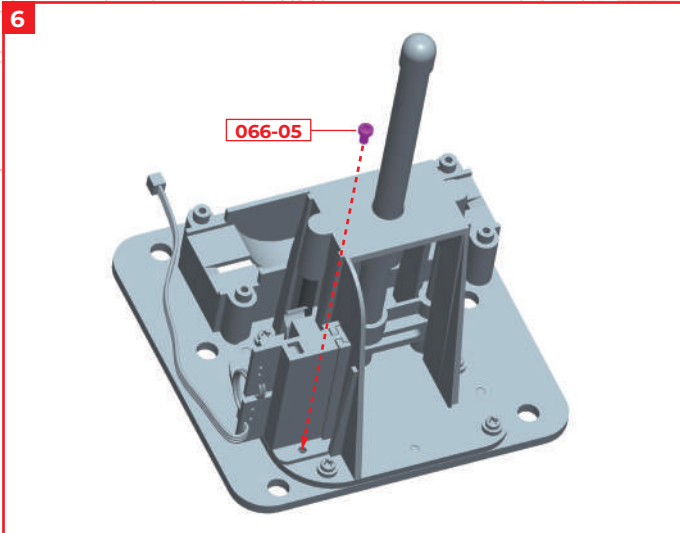

Fix the limit switch frame 061-02 in place with 1 x screw 066-05.

STAGE COMPLETE

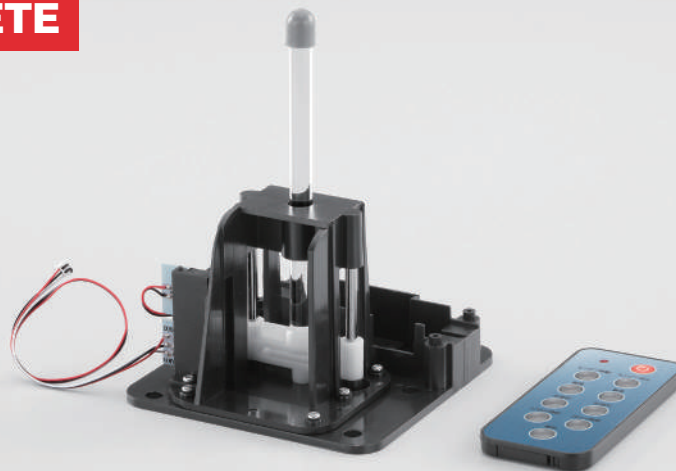

Stage 67: Assembling the Gearbox for the Lifting Device



Stage 67 Assembly

Lifting Device Gearbox

In this stage we'll be assembling the gearbox for the lifting device. There are four gears to assemble here, so make sure everything's done in the correct order and all of the gears are facing in the right direction so they properly mesh.

STAGE 67 PARTS

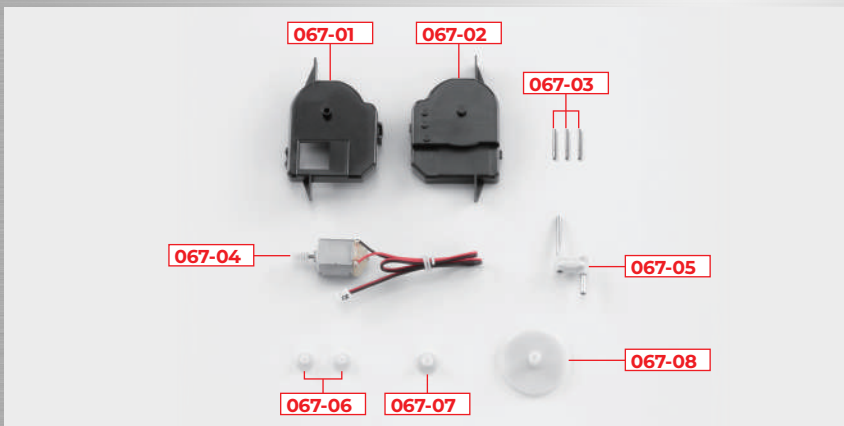

You will also need: screwdriver

*Parts may differ slightly from those shown but this will not affect assembly.

PARTS LIST

	PART	No.	MATERIAL
<input type="checkbox"/>	067-01	1	ABS resin
<input type="checkbox"/>	067-02	1	ABS resin
<input type="checkbox"/>	067-03	3	Steel
<input type="checkbox"/>	067-04	1	Motor
<input type="checkbox"/>	067-05	1	Steel+Plastic
<input type="checkbox"/>	067-06	2	Plastic
<input type="checkbox"/>	067-07	1	Plastic
<input type="checkbox"/>	067-08	1	Plastic

STEP 1

Assembling the gearbox for the lifting device

← : Glue
 - - - : Don't Glue

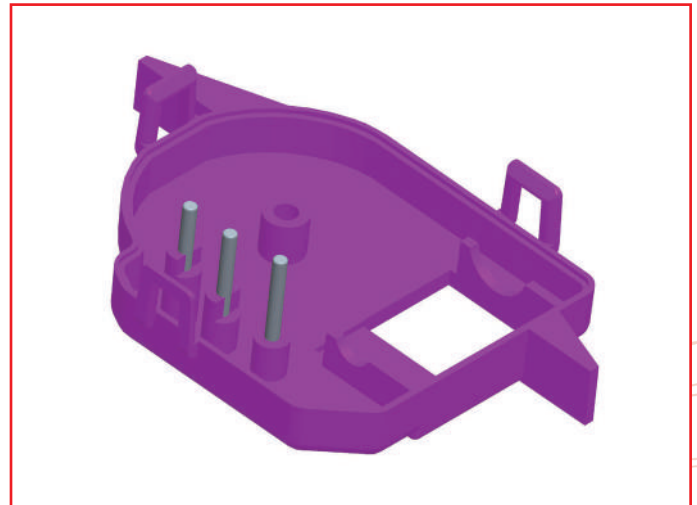
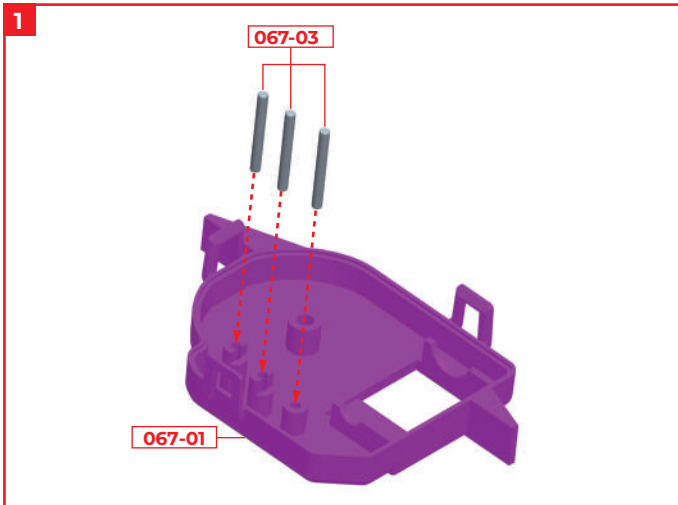

Insert three shafts 067-03 into the gearbox 067-01. The holes are a little narrow, so make sure to insert them all the way.

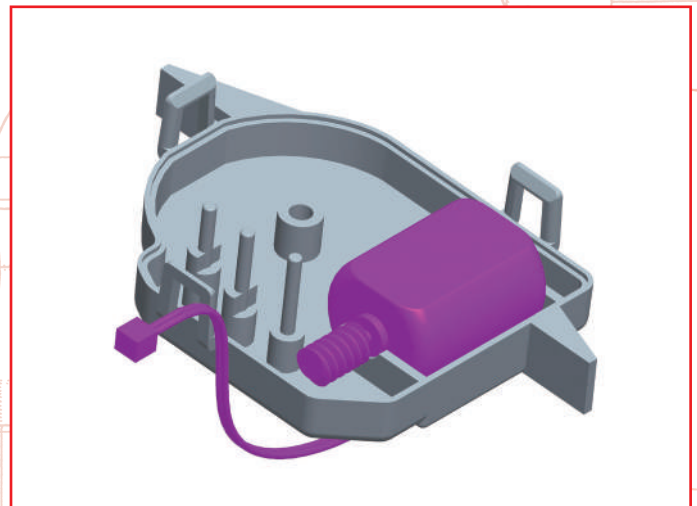
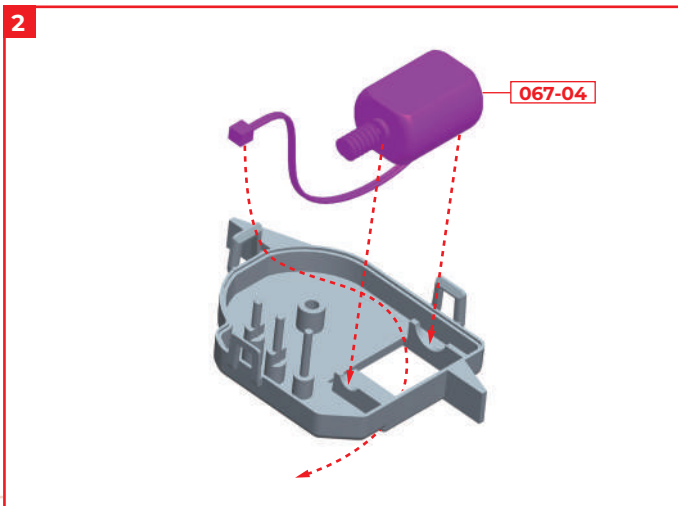

Insert the wire of motor 067-04 through the hole of gearbox 067-01 and fit it with the wire side down.

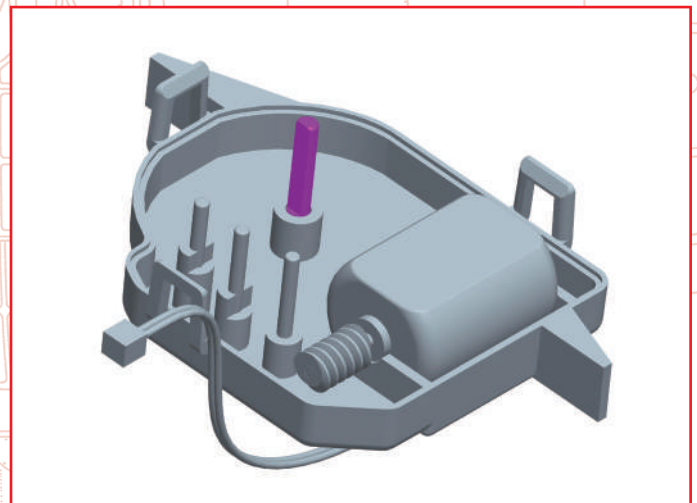
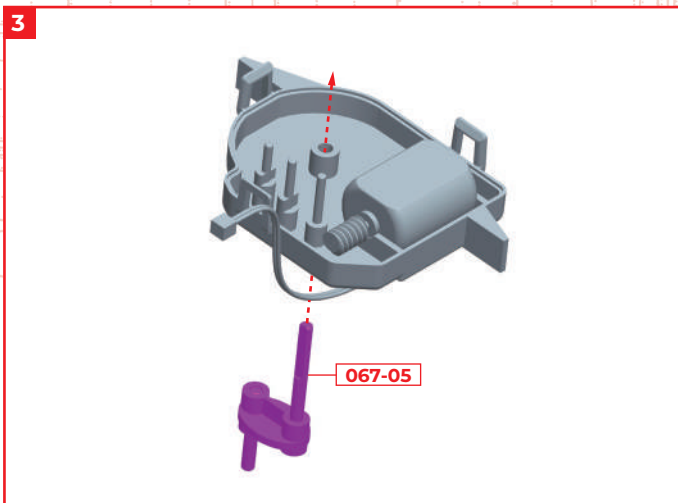

Insert the longer shaft of camshaft 067-05 from underneath gearbox 067-01.

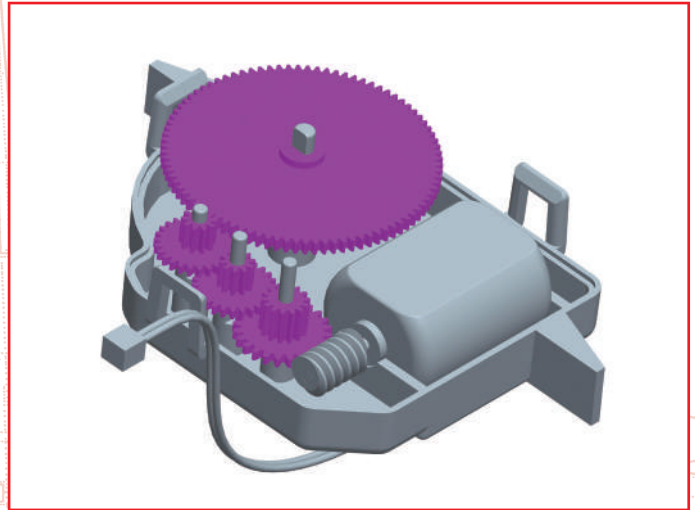
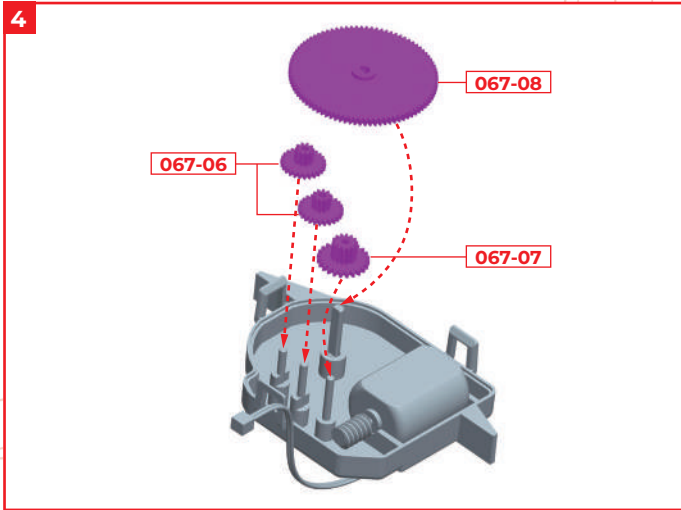

Insert two gears 067-06 and gear 067-07 onto the three shafts 067-03 inserted in 1, in the order shown in the figure with the smaller gear facing up. Finally, fit the gear 067-08 onto the camshaft 067-05 inserted in step 3 with the small gear facing down. Make sure the four gears are in good contact.

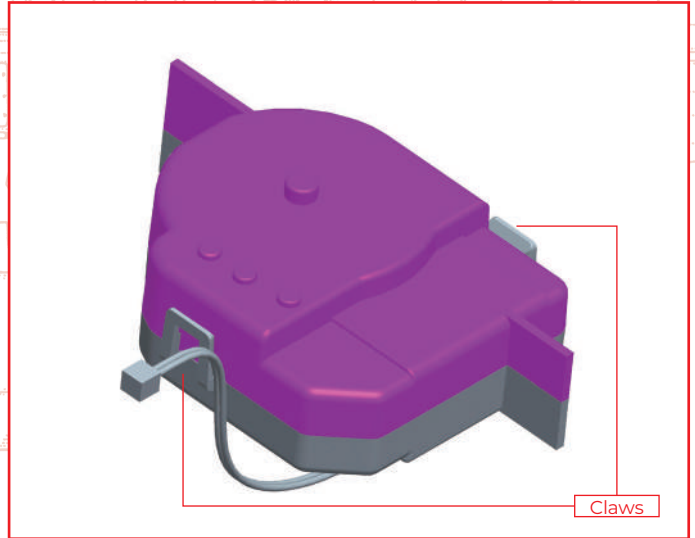
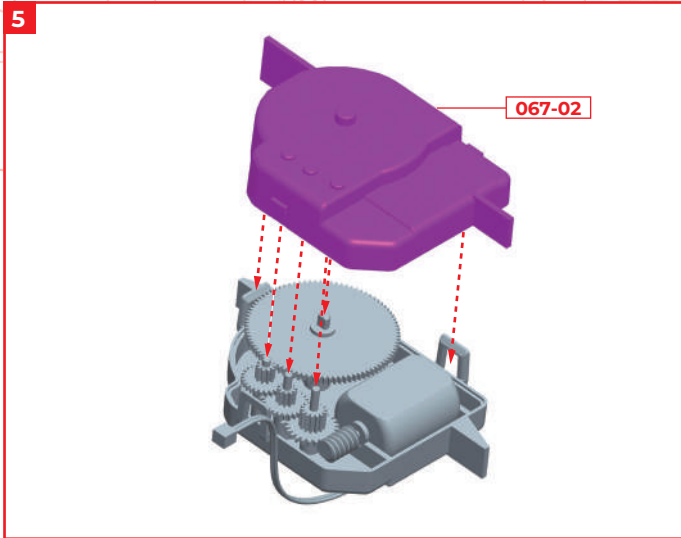

Cover the gearbox 067-01 with the gearbox cover 067-02 and fit the claws.

STAGE COMPLETE



Stage 68: Attaching the Underside Panel of the Left Wing

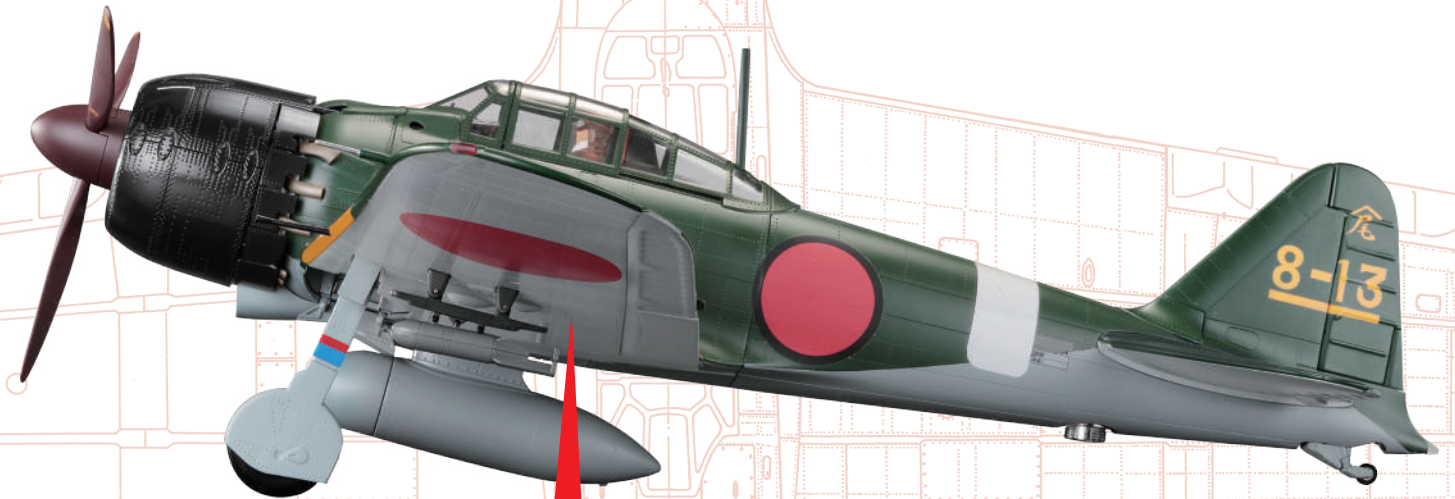

Stage 68 Assembly

Underside Panel

In this stage we'll be attaching the underside panel for the left wing.

STAGE 68 PARTS

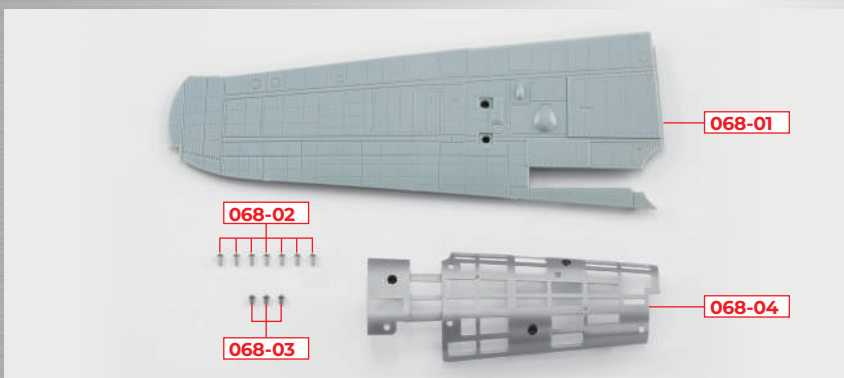

You will also need: screwdriver

*068-04 is not used in this stage. Keep it in a safe place until required.

*Parts may differ slightly from those shown but this will not affect assembly.

PARTS LIST

	PART	No.	MATERIAL
<input type="checkbox"/>	068-01	1	ABS resin
<input type="checkbox"/>	068-02	7 (1 spare)	Steel
<input type="checkbox"/>	068-03	3 (1 spare)	Steel
<input type="checkbox"/>	068-04	1	ABS resin

STEP 1

Installing the left wing underside panel

← : Glue
- - - : Don't Glue

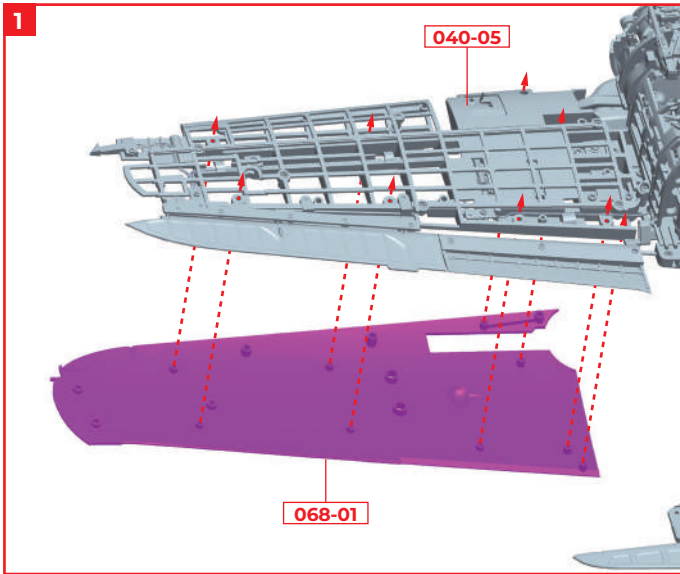

NOTE

When aligning the left wing bottom panel 068-01 with the left wing frame, make sure to align the 9 screw holes and protrusions to avoid distorting or damaging the parts.

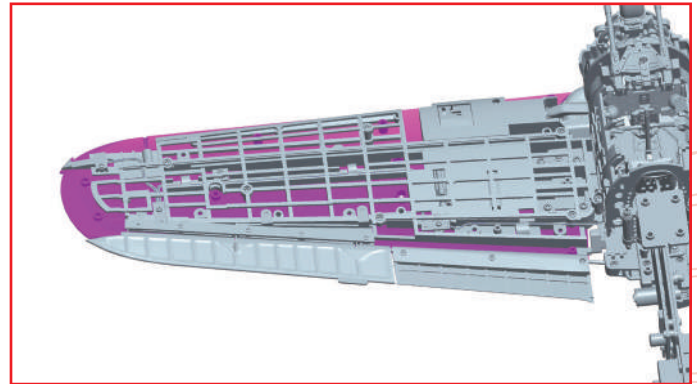

Align the left wing bottom panel 068-01 with the outer frame 040-05 of the left wing frame.

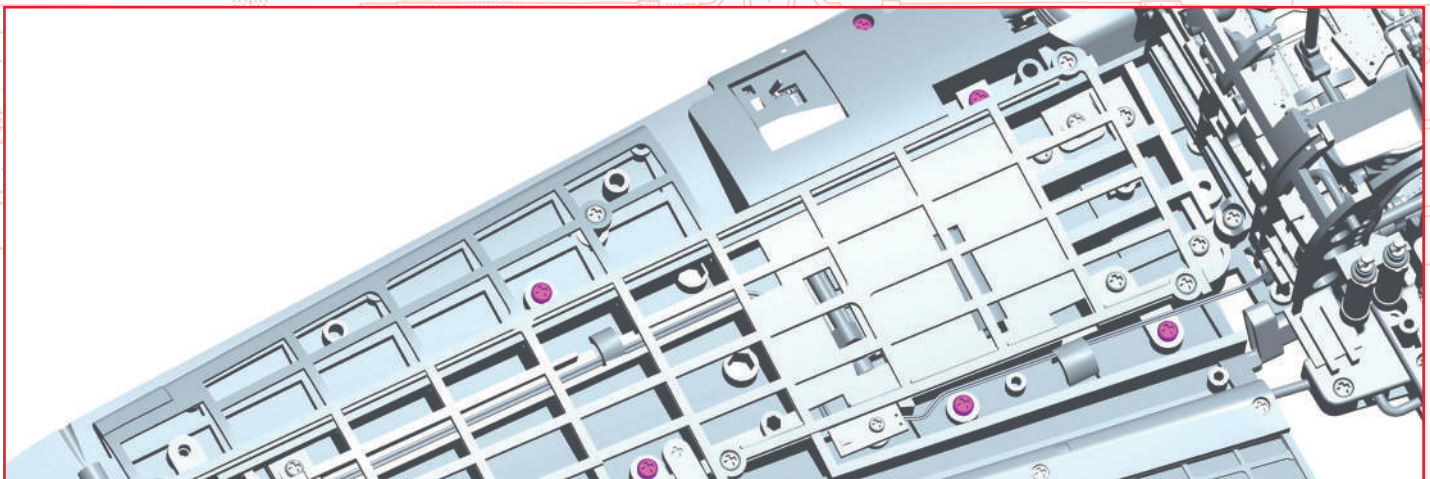
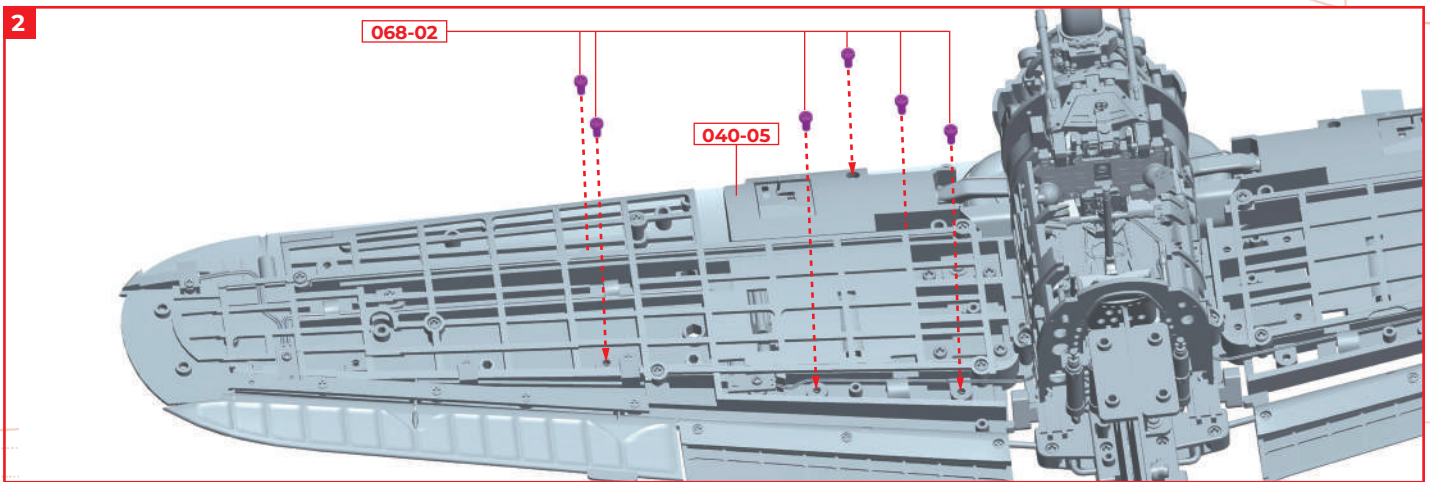

Fix the left wing bottom panel to the outer frame with 6 x screws 068-02. Try to tighten all the screws little by little.

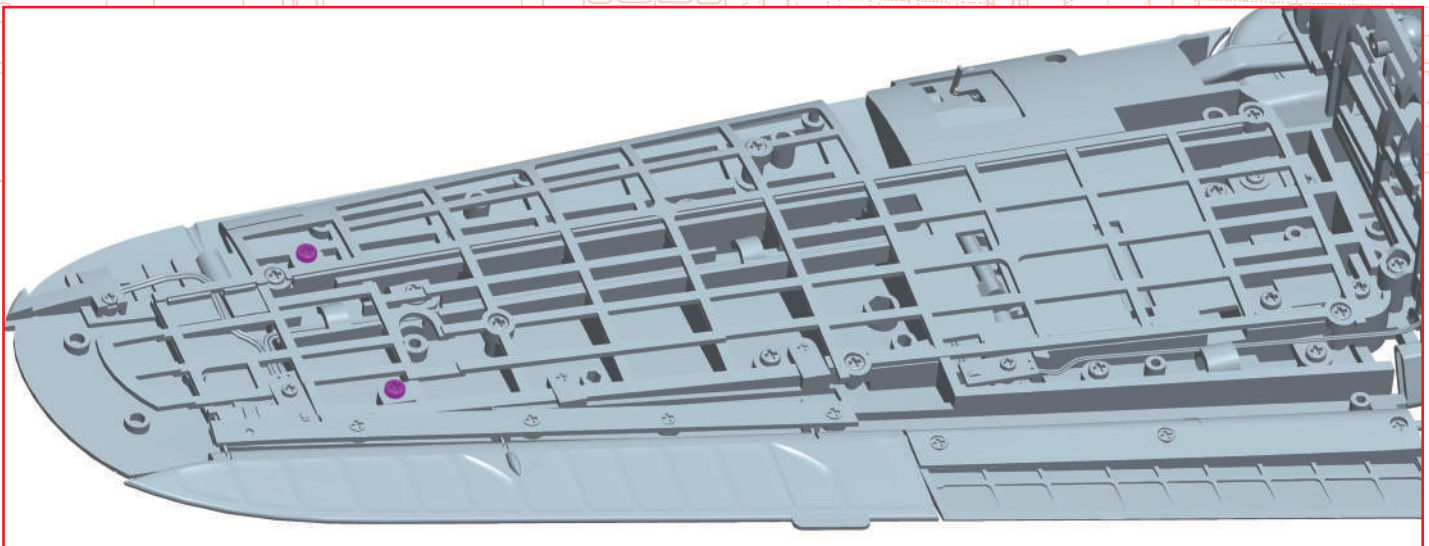
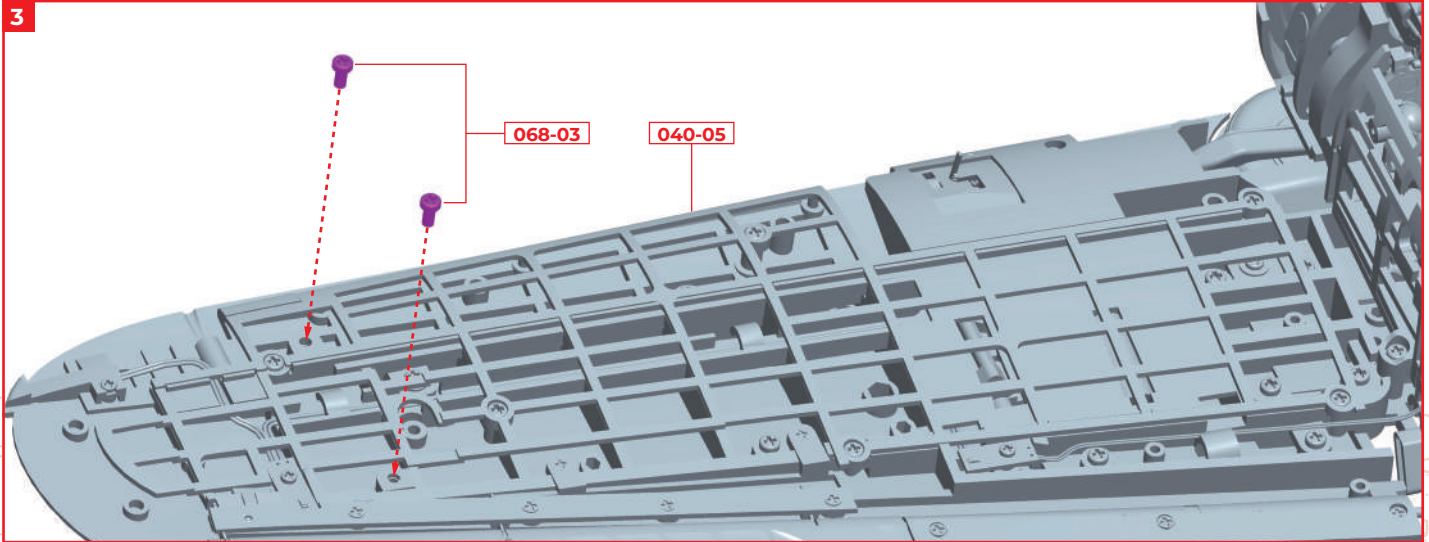

Fix two more parts of the left wing bottom panel 068-01 to the outer frame 040-05 of the left wing with 2 x screws 068-03. Try to tighten the two screws little by little.

STAGE COMPLETE

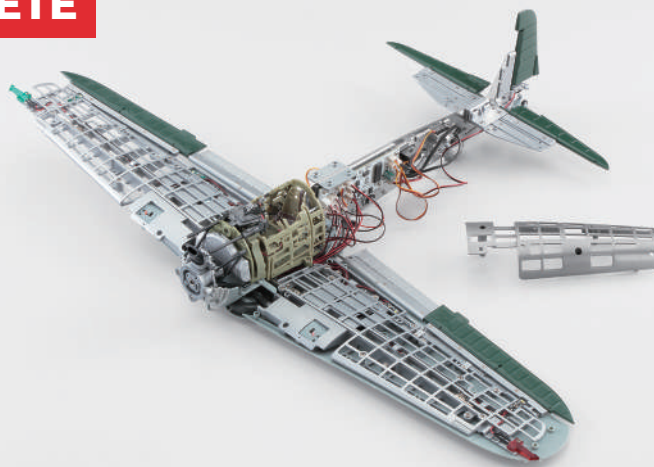

Stage 69: Assembling the Limit Switch and Display Pedestal



Stage 69 Assembly

Limit Switch & Pedestal

In this stage we'll be assembling the limit switch for the lifting device as well as carrying on working on the pedestal itself.

STAGE 69 PARTS

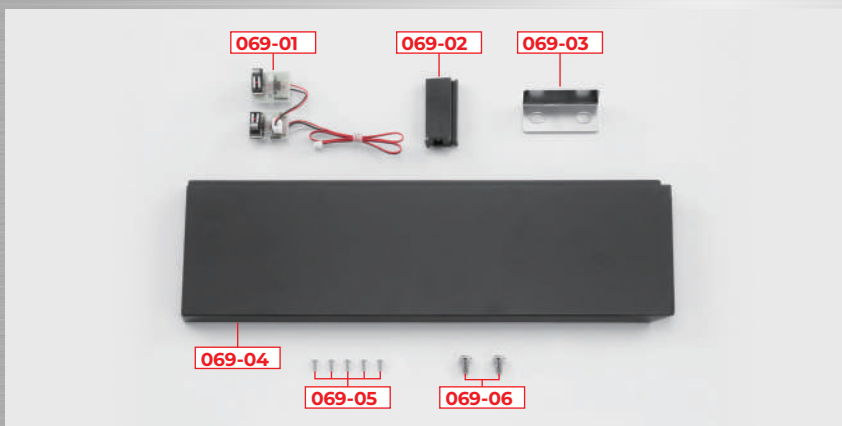

You will also need: screwdriver
 *Parts may differ slightly from those shown but this will not affect assembly.

PARTS LIST

	PART	No.	MATERIAL
<input type="checkbox"/>	069-01	1	Limit Switch
<input type="checkbox"/>	069-02	1	ABS resin
<input type="checkbox"/>	069-03	1	Steel
<input type="checkbox"/>	069-04	1	MDF
<input type="checkbox"/>	069-05	5 (1 spare)	Steel
<input type="checkbox"/>	069-06	2	Steel

STEP 1

Assembling the limit switch

← : Glue
- - - : Don't Glue

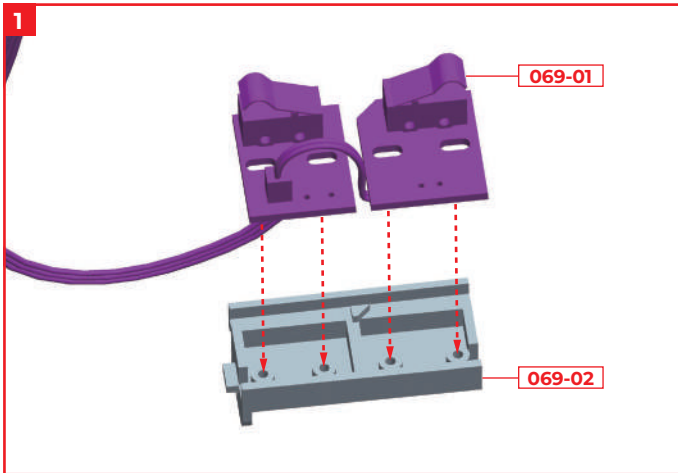

Align the oval screw holes of the limit switch 069-01 with the four screw holes of the frame 069-02 and fit them. Pay attention to the direction of the switch.

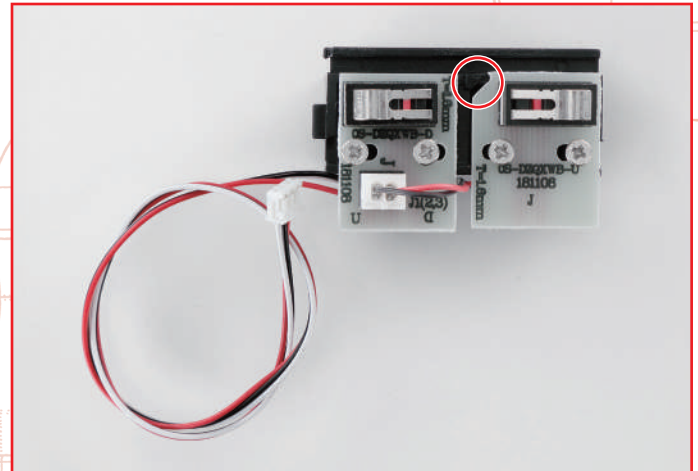
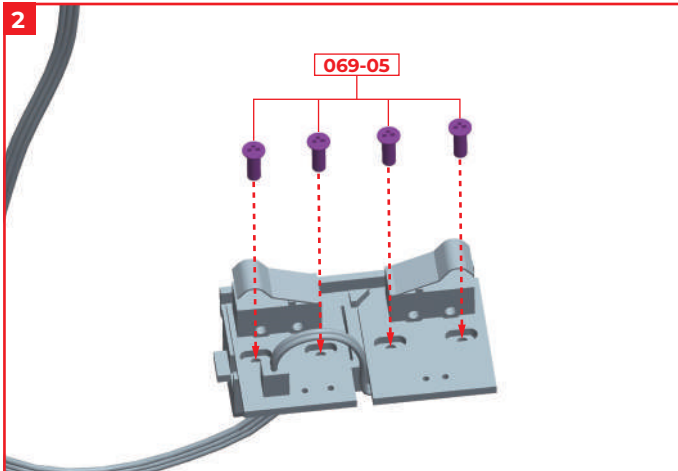

Fix the limit switch to the frame with 4 x screws 069-05.

STEP 2

Assembling the display pedestal

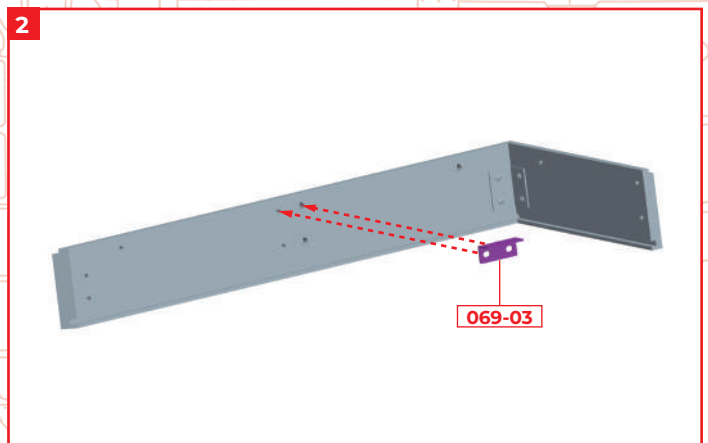
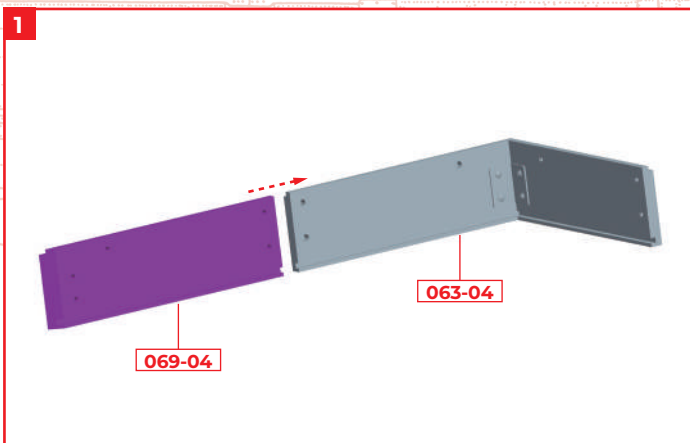

Align the pedestal frame 069-04 with the pedestal frame 063-04 as assembled in stage 63.

Align the holes in the pedestal frames 063-04 and 069-04 with the metal fittings 069-03.

3

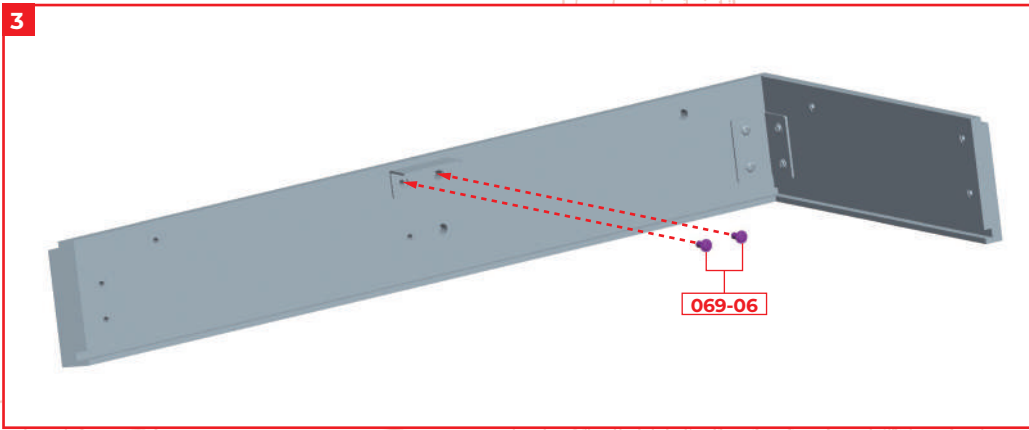

Fix the metal fittings in place with 2 x screws **069-06**, taking care not to shift the pedestal frame.

4

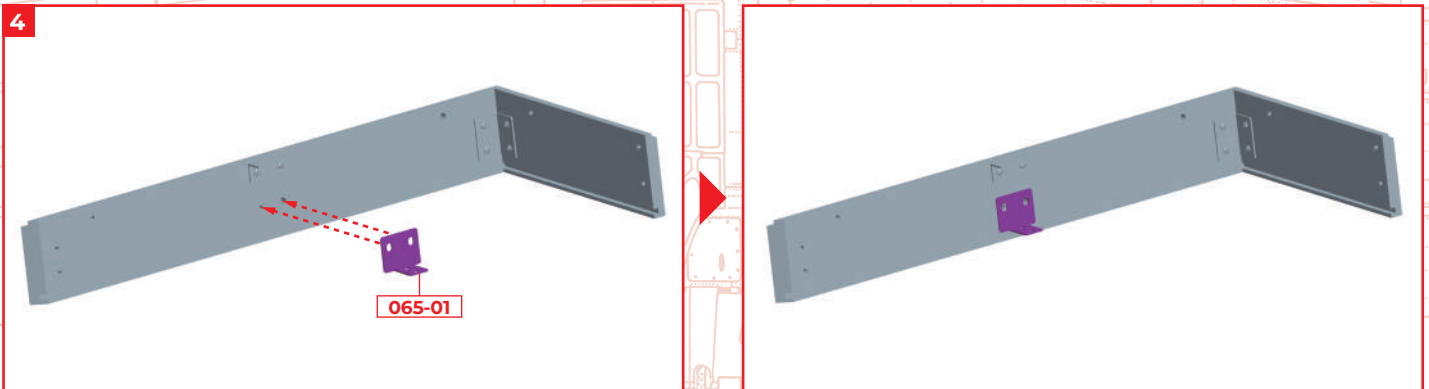

Align the holes in the pedestal frames **063-04** and **069-04** with the metal fittings **065-01** that came with stage 65.

5

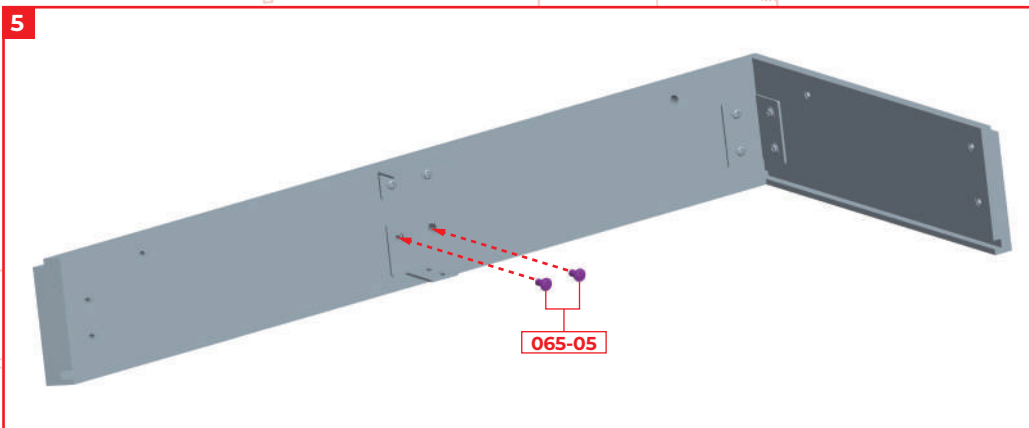

Fix the metal fittings in place with 2 x screws **065-05** that came with stage 65.

STAGE COMPLETE

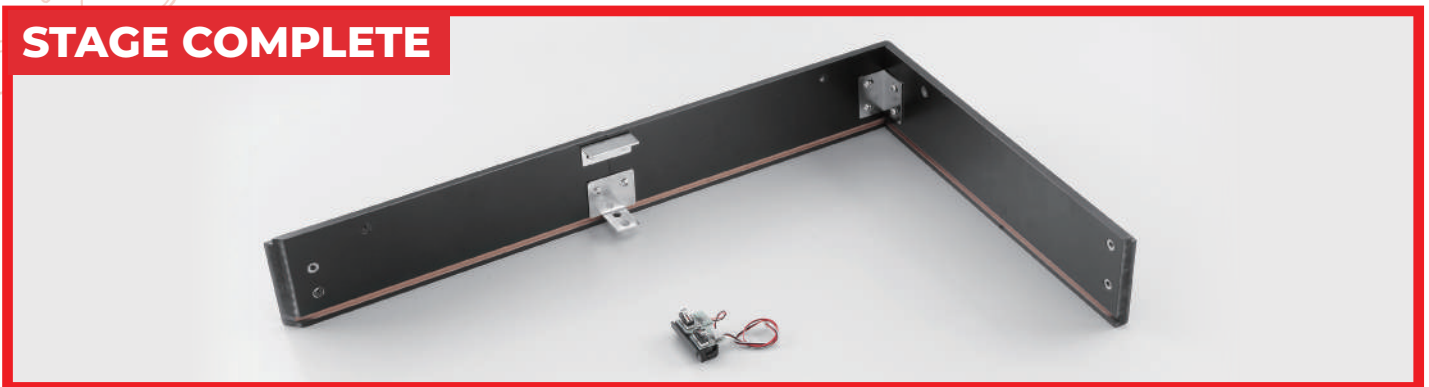

Stage 70: Attaching the Underside Panel of the Right Wing



Stage 70 Assembly

Underside Panel

In this stage we'll be attaching the underside panel for the right wing.

STAGE 70 PARTS

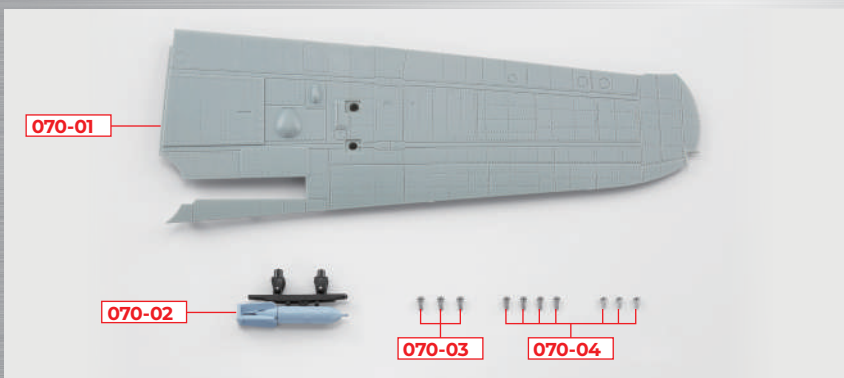

PARTS LIST

	PART	No.	MATERIAL
<input type="checkbox"/>	070-01	1	ABS resin
<input type="checkbox"/>	070-02	1	ABS resin
<input type="checkbox"/>	070-03	3 (1 spare)	Steel
<input type="checkbox"/>	070-04	7 (1 spare)	Steel

You will also need: screwdriver

* **070-02** will not be used in this stage. Keep it in a safe place until required in a later stage.

* Parts may differ slightly from those shown but this will not affect assembly.

STEP 1

Installing the right wing underside panel

← : Glue
 ← : Don't Glue

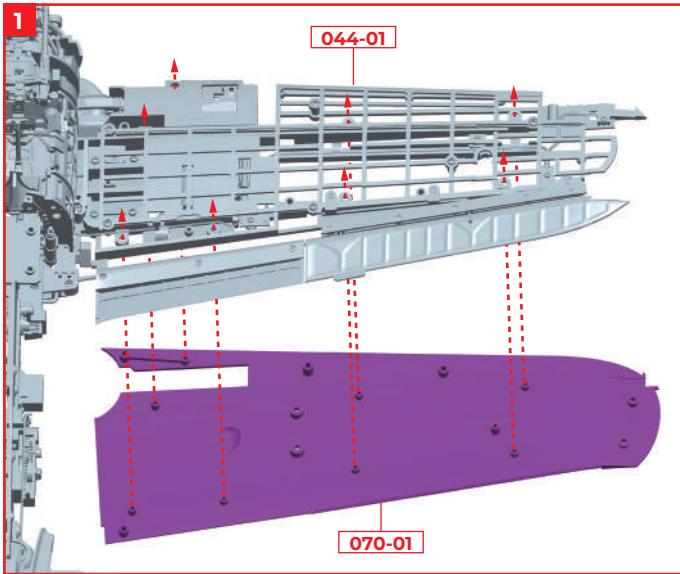

NOTE
 Before fastening everything together with screws, identify the eight holes and protrusions you'll be working with. Not doing so may result in the wing warping or breaking, so take due care.

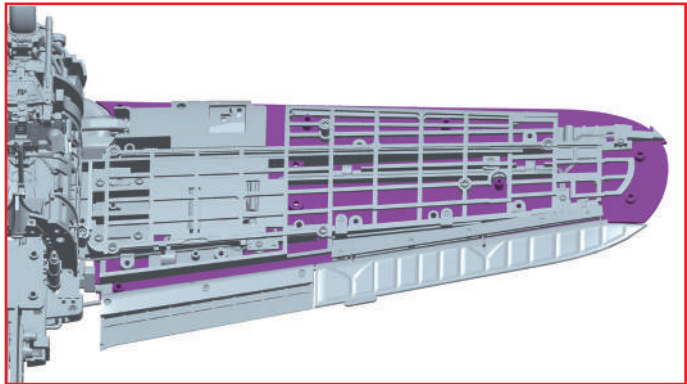

Align the right wing bottom panel 070-01 with the right wing frame 044-01.

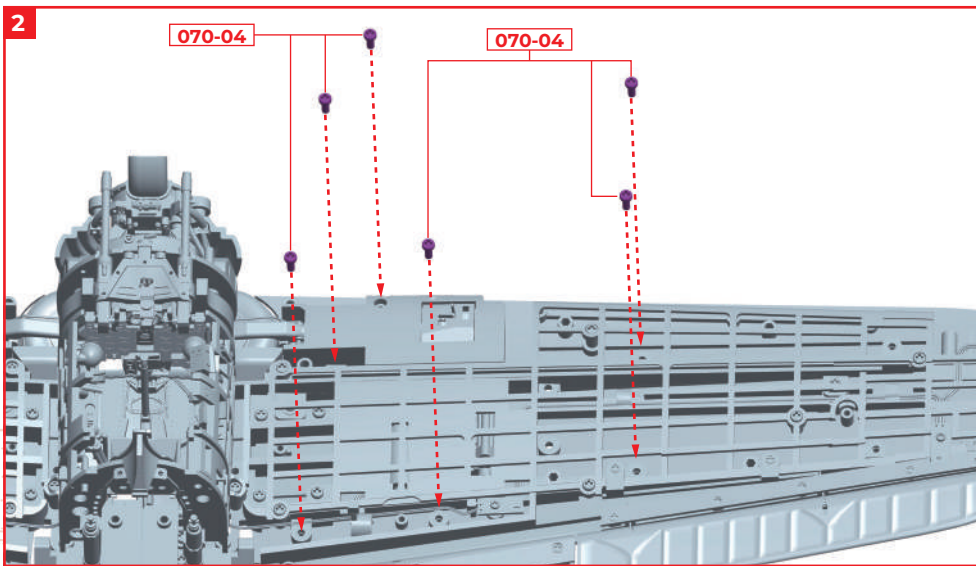

Fix the right wing bottom panel 070-01 to the right wing frame 044-01 with 6 x screws 070-04. Insert each screw a little way, and then tighten them little by little.

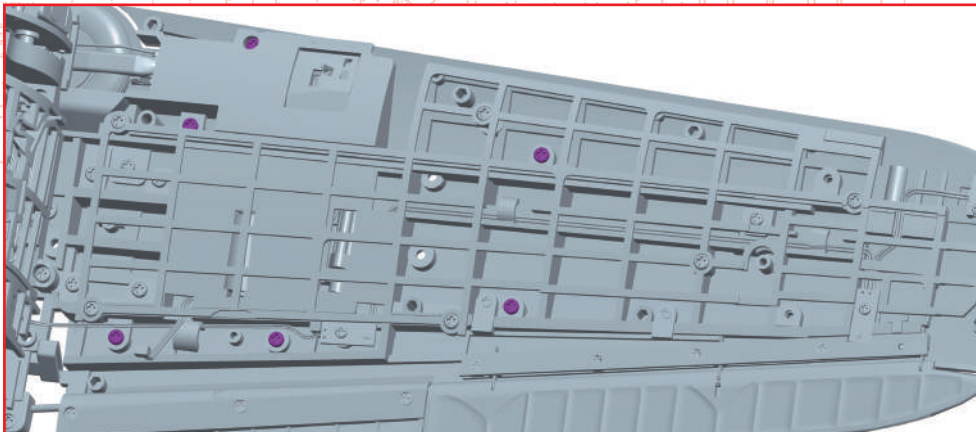

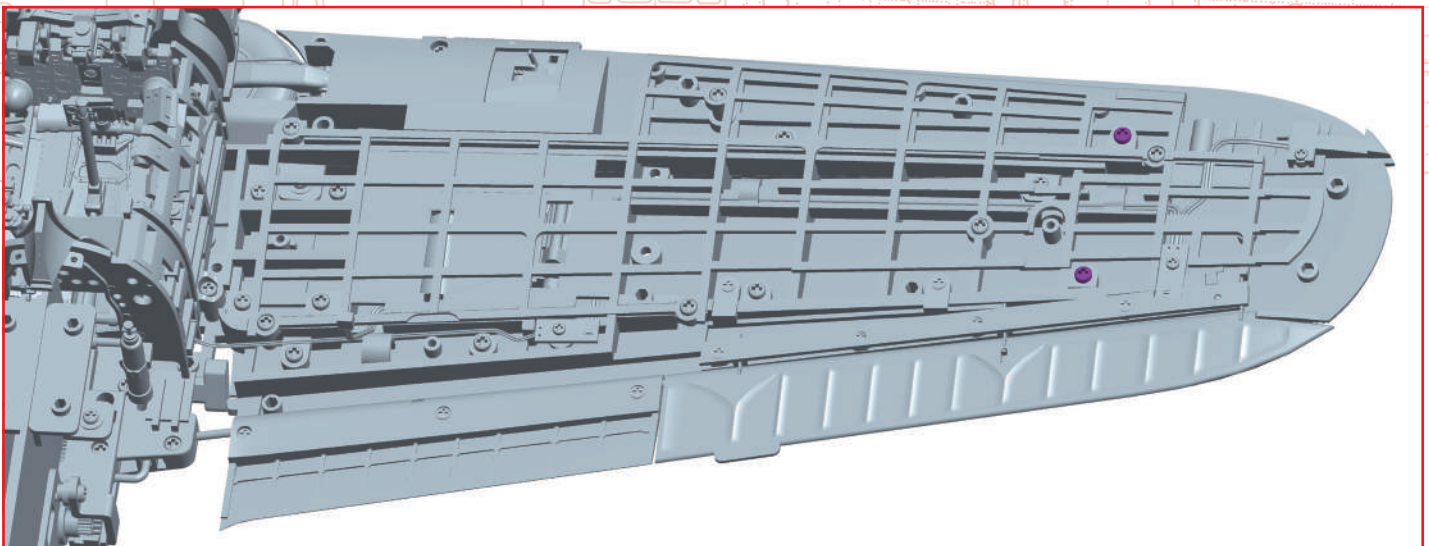
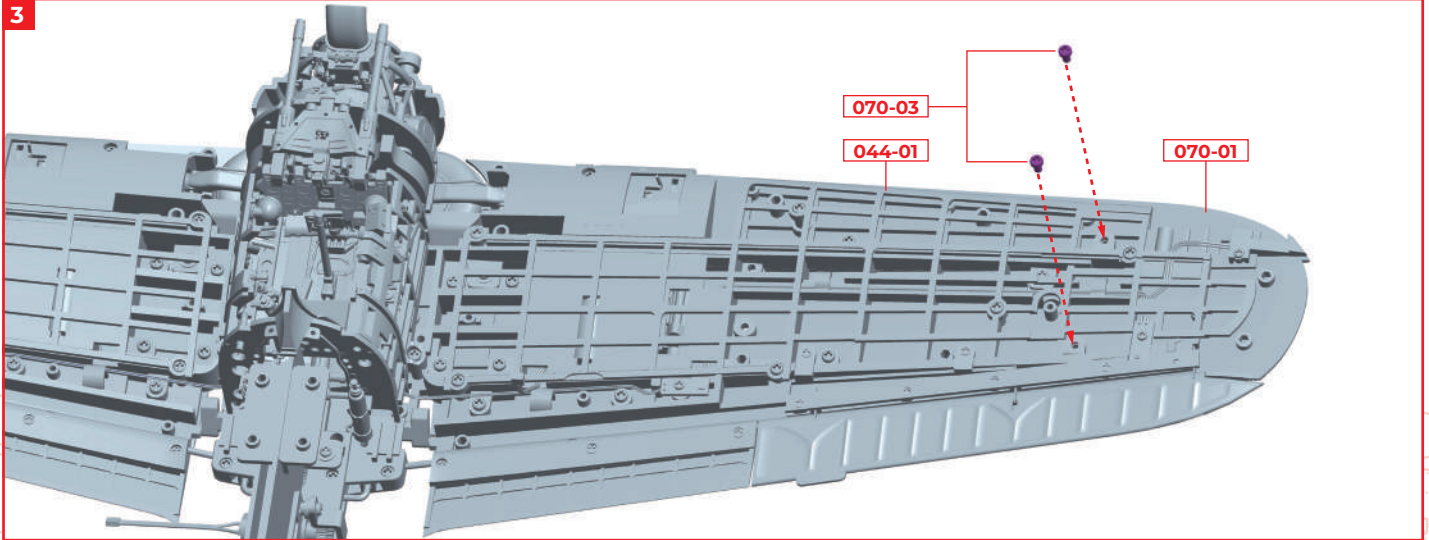

Continue to fix the two parts of the right wing bottom panel 070-01 to the right wing frame 044-01 now using 2 x crews 070-03. Try to tighten the two screws little by little.

STAGE COMPLETE

