

STEVE MCQUEEN'S ICONIC
PORSCHE
917KH



Pack 02

BUILD INSTRUCTIONS

STAGE 06: LEFT-SIDE OF GEARBOX AND TRANSMISSION JOINT

STAGE 07: RIGHT-SIDE OF ENGINE BLOCK

STAGE 08: PREPARING THE OIL PUMP AND CYLINDERS

STAGE 09: ATTACHING THE RIGHT CYLINDER HEAD

STAGE 10: ASSEMBLE AND FIT THE CRANKCASE TOP

STAGE 11: LEFT-SIDE OF ENGINE BLOCK

STAGE 12: BUILDING THE FUEL PUMP

Porsche, the Porsche shield and the distinctive design of Porsche cars are trademarks and trade dress of Porsche AG. Permission granted.

The Gulf trademarks are used under license from Gulf Oil International Ltd.

Personality rights of Steve McQueen are used with permission of Chadwick McQueen and The Terry McQueen Testamentary Trust.

Represented exclusively by Greenlight.

AGORA
MODELS

Advice from the experts

Spare screws are included with each part. Occasionally, you may be instructed to keep spare or unused screws for a later stage. Keep these spares in a safe place and label them correctly.

Please make sure you don't mix up the screws. They look quite similar, but the threads do vary slightly. Using the wrong screws may damage the parts.

When securing parts together using multiple screws, fit each screw loosely to ensure all the parts are correctly aligned before gently tightening them firmly, but not overtight, in the order in which you placed them.

The screwdriver can be magnetized by stroking it with a magnet (fridge magnet, etc.) enabling it to hold the screws and make assembly easier.

If a screw is tight going into a metal part, do not force it as you may shear the head off. Remove it and put a tiny smear of Vaseline, soap or light oil on the thread. That will lubricate it and make it easier to drive home.

During the course of this build, you will receive many pieces that you will assemble immediately – following the instructions in the corresponding stage – and other pieces that you should store safely to one side, for use in future assembly stages.

Left and Right! When building your Porsche 917KH, the left or right hand side refers to each side as you are sitting in the car.



WARNING: Some parts are assembled using magnets. These magnets can cause serious injury if they are swallowed. Keep away from children. If you suspect a magnet has been swallowed, seek medical help straight away.

STAGE 06: LEFT-SIDE OF GEARBOX AND TRANSMISSION JOINT

- 6A** Left gearbox housing
- 6B** Left-side mounting bracket
- 6C** Transmission seal
- 6D** Crosspiece
- 6E** Transmission flexible joint
- 6F** Flex disc (inner)
- 6G** Flex disc (outer)

- 6H** Cardan socket
- IM** Screw 1.7 x 3.5mm (x8)
- FM** Screw 1.7 x 4mm (x7)
- GM** Screw 1.7 x 5mm (x5)
- BM** Screw 2.0 x 4mm (x4)
- CM** Screw 2.0 x 3 x 5mm (x2)

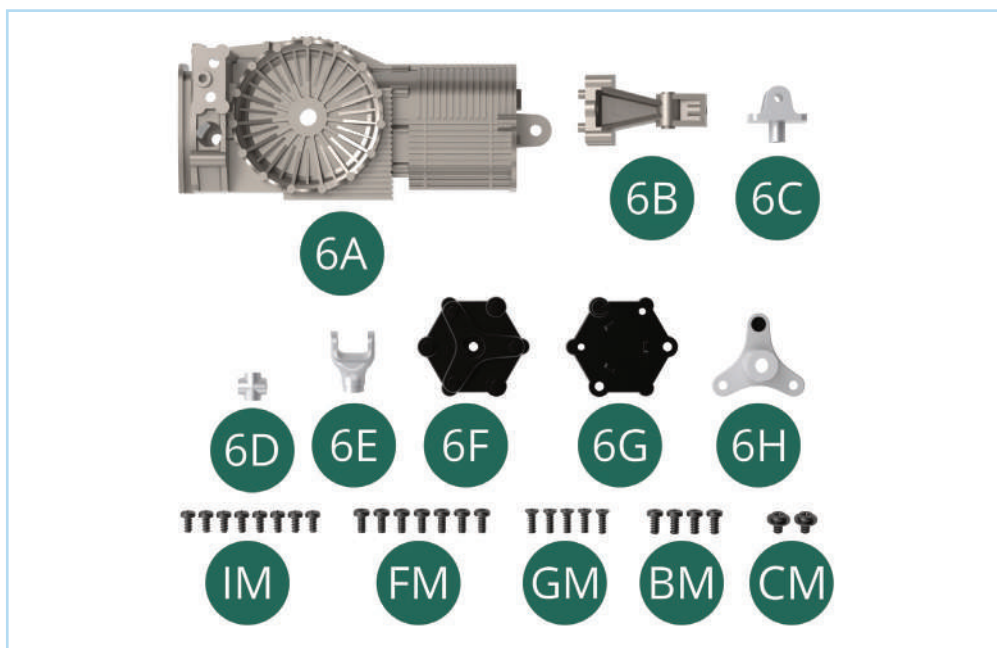

ASSEMBLY DIAGRAM

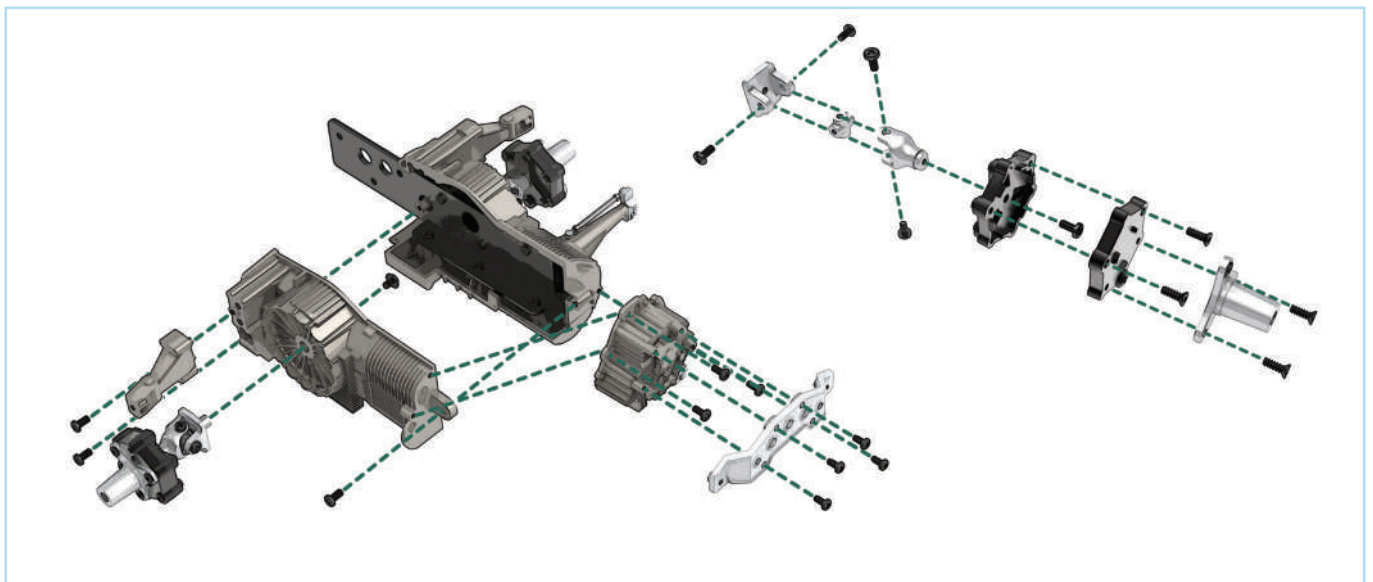

STAGE 06: LEFT-SIDE OF GEARBOX AND TRANSMISSION JOINT

STEP 1

Position the **left mounting bracket (6B)** on the **left gearbox housing (6A)** and secure it in place with a **BM** screw.

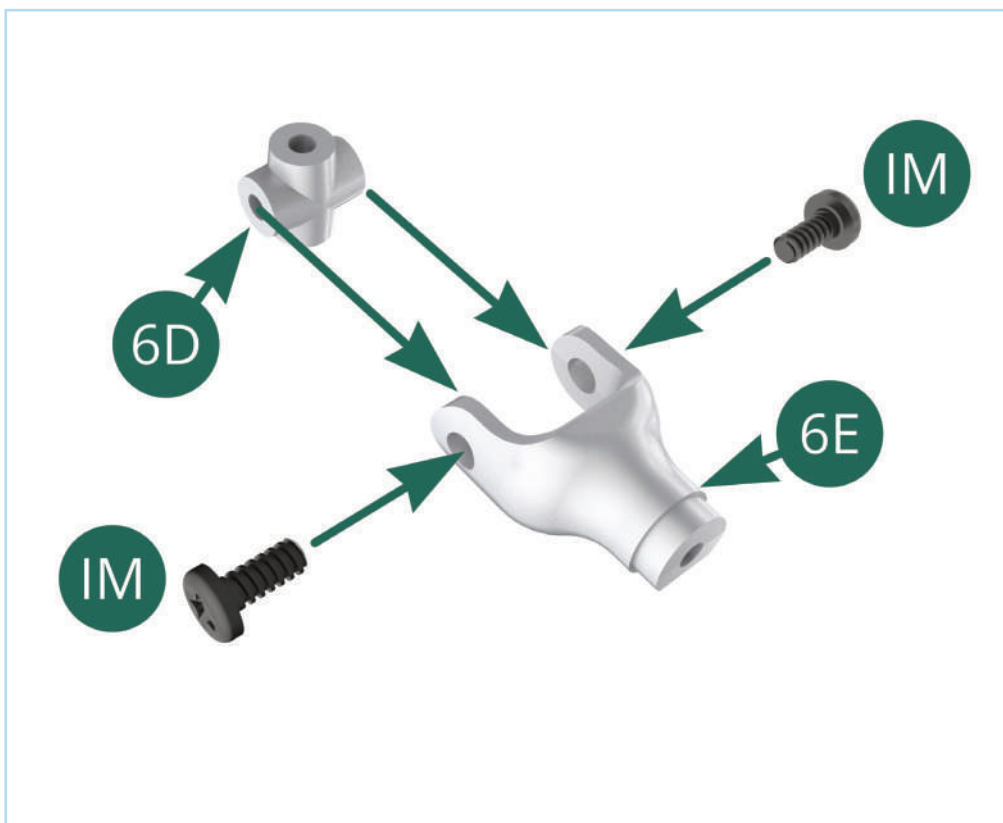
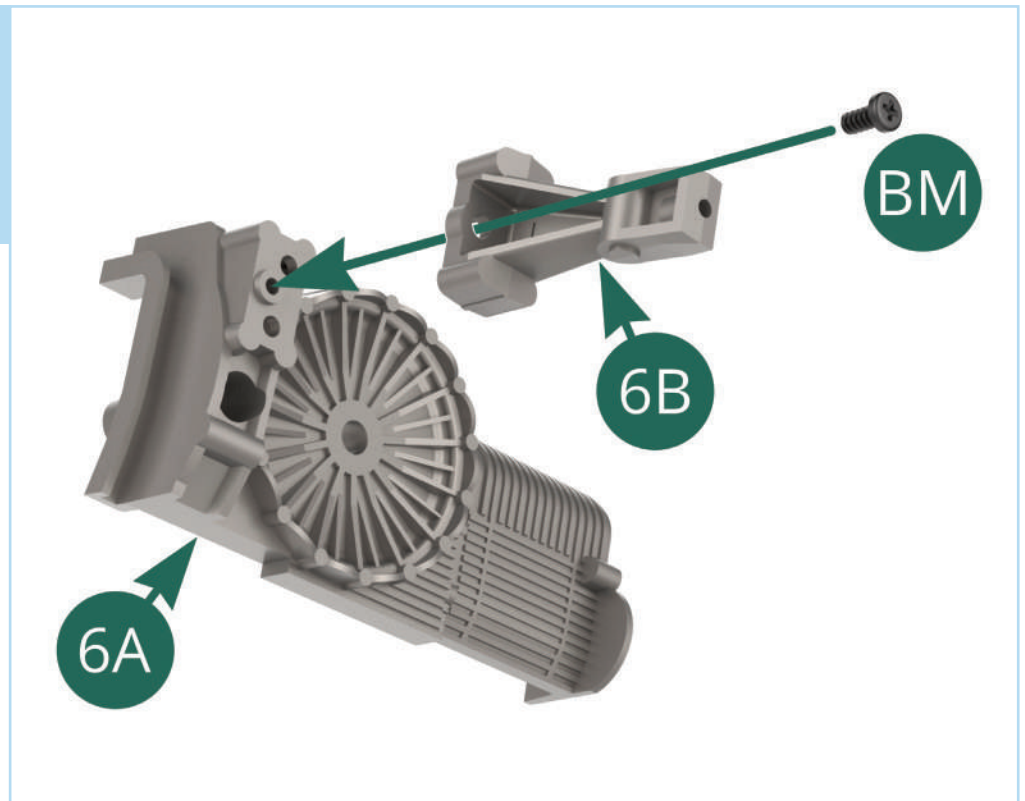

Take the **crosspiece (6D)** and fit it into the **transmission flexible joint (6E)** as shown. Secure the parts with two **IM** screws.

Tip: You may find it easier to partially tighten the screws at this step, then fully tighten after completing Step 2.

STAGE 06: LEFT-SIDE OF GEARBOX AND TRANSMISSION JOINT

STEP 2

Fit the **transmission seal (6C)** onto the **crosspiece (6D)** and secure it with two **FM** screws. Don't over tighten the **FM** screws as the joint should be free to move.

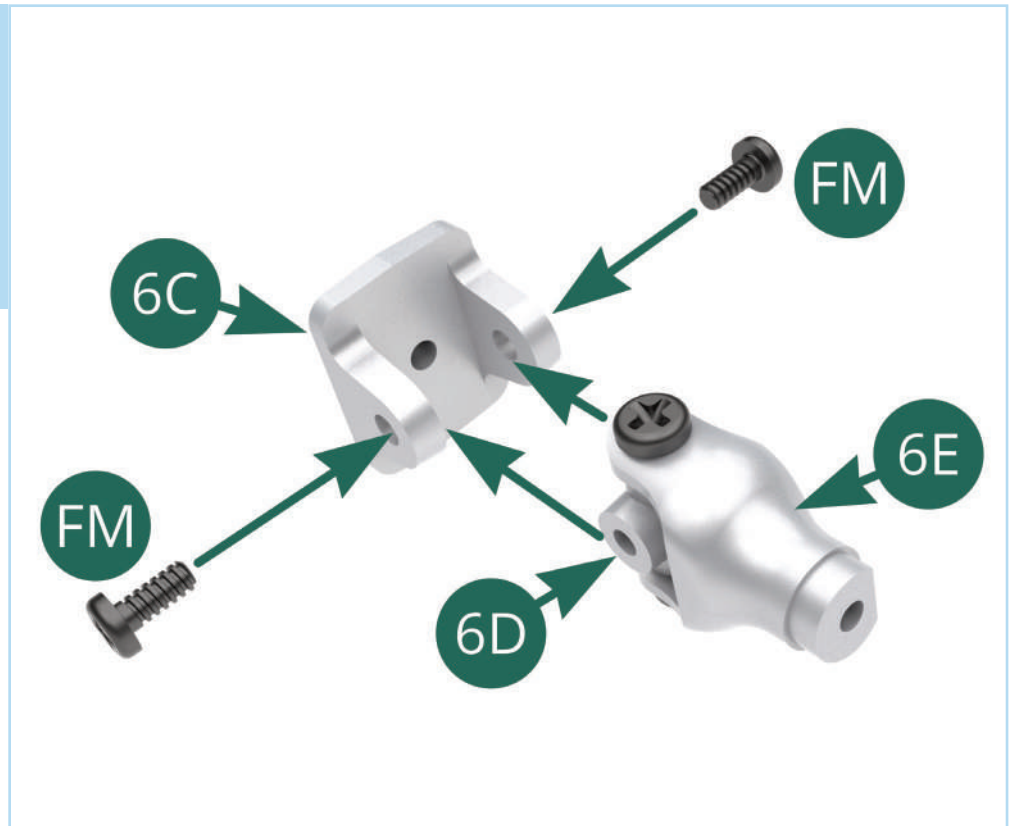

Fit the **inner flex disc (6F)** onto the **transmission flexible joint (6E)** as shown and secure it in place with an **IM** screw.

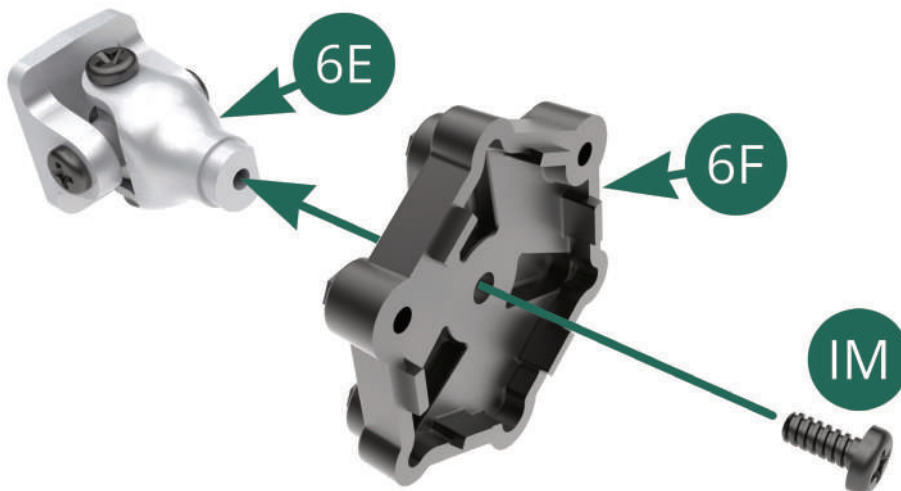

You can lubricate the thread of the screw with a drop of oil if it is difficult to screw in.

STAGE 06: LEFT-SIDE OF GEARBOX AND TRANSMISSION JOINT

STEP 3

Fit the **outer flex disc (6G)** onto the **inner flex disc (6F)** and secure it in place with two **GM** screws. Note the false 'screw' (orange arrow) on the outer disc.

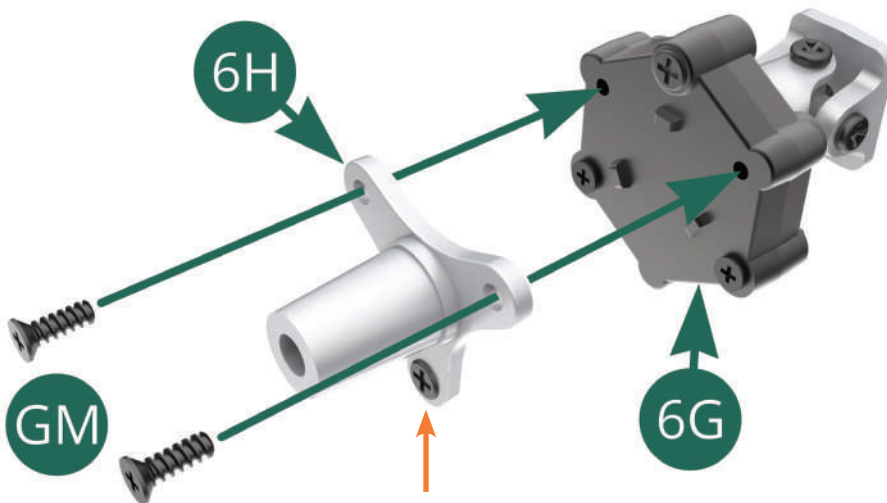
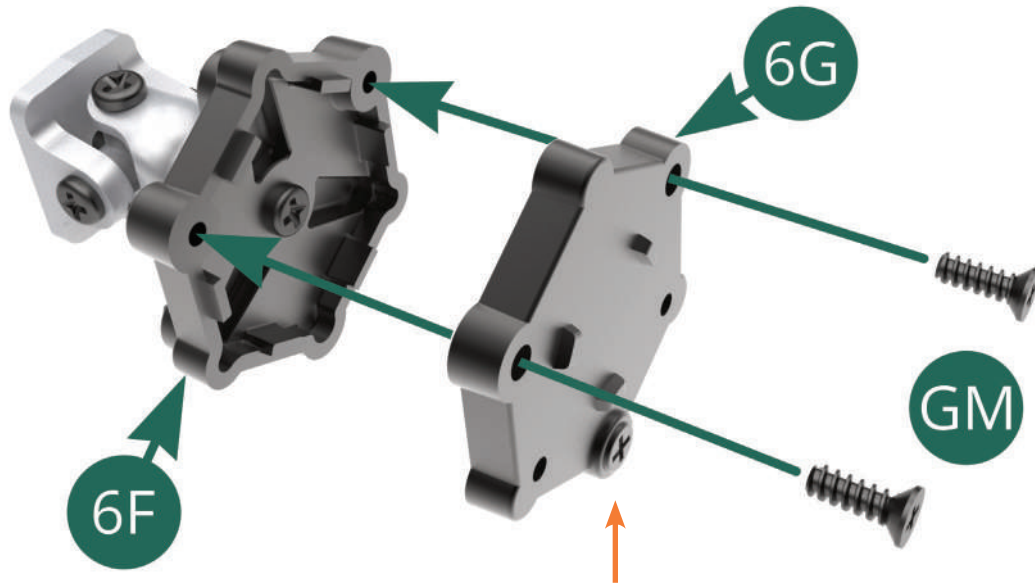

Take the **cardan socket (6H)** and align it with the **outer flex disc (6G)** as shown. Note the false 'screw' (orange arrow) on the socket is opposite the previous false 'screw'.

Hold the socket in place and secure it with two **GM** screws.

STAGE 06: LEFT-SIDE OF GEARBOX AND TRANSMISSION JOINT

STEP 4

Push the **transmission joint (6C)** through the hole in the **left gearbox housing (6A)**. Fix in place using a **CM** screw as shown.

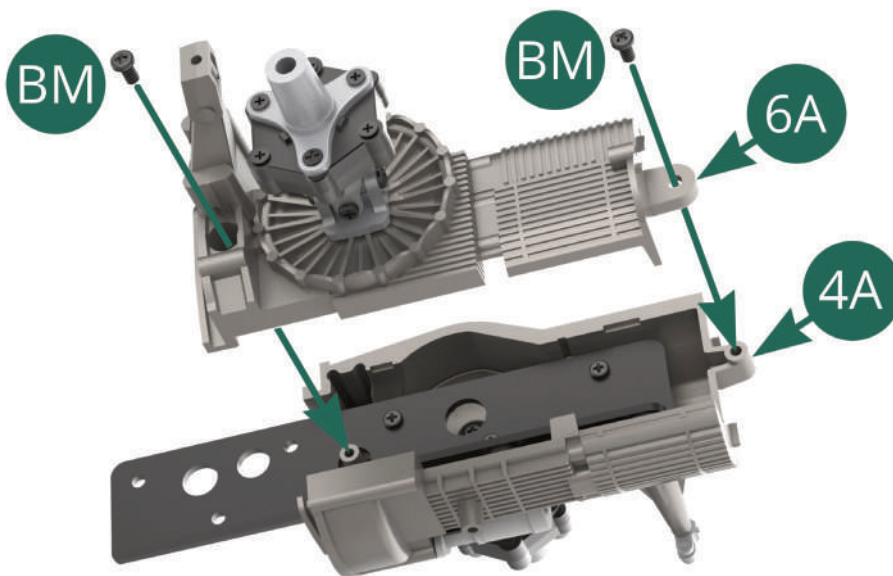
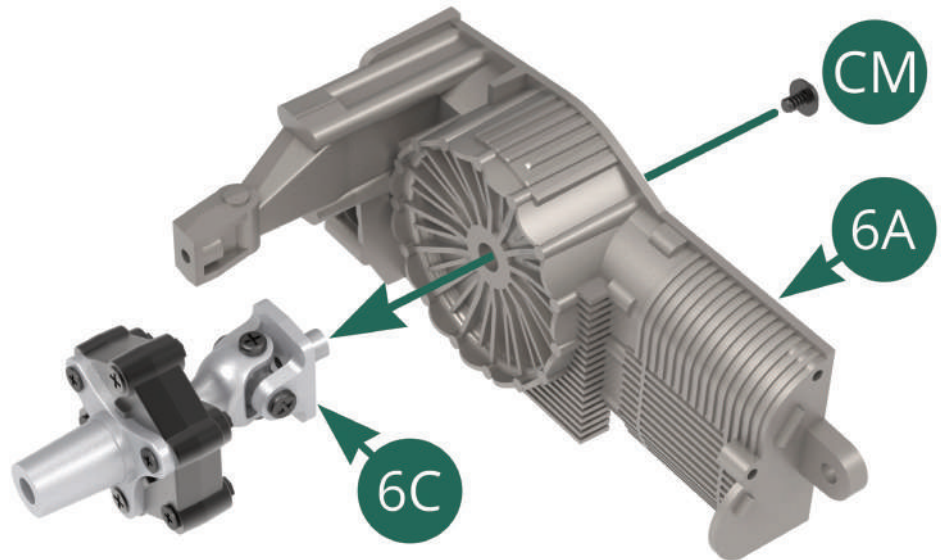

Position the **left gearbox cover (6A)** onto the **right gearbox cover (4A)** from Stage 4 and connect the two parts together using two of the **BM** screws.

STAGE 06: LEFT-SIDE OF GEARBOX AND TRANSMISSION JOINT

STEP 5

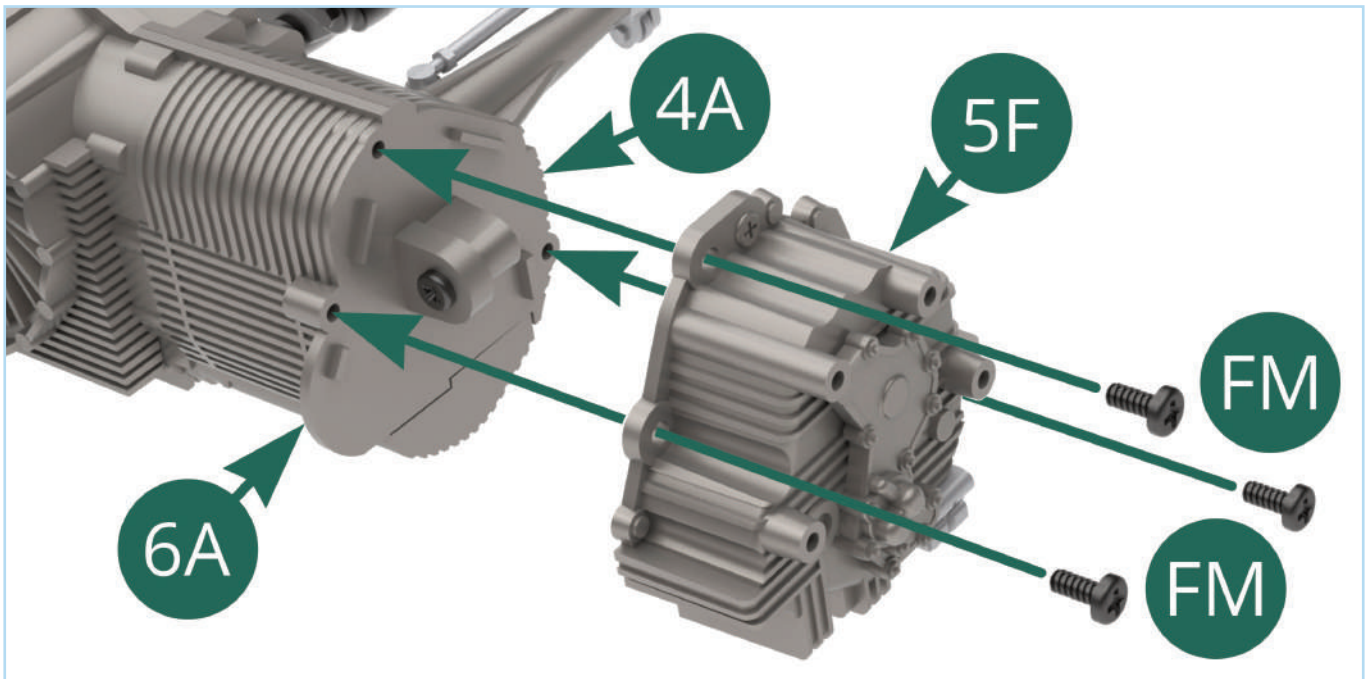

Take the **gearbox rear cover (5F)** from Stage 5 and place it onto the end of the gearbox cover assembly (**4A** and **6A**) as shown. Secure the rear cover using three **FM** screws.

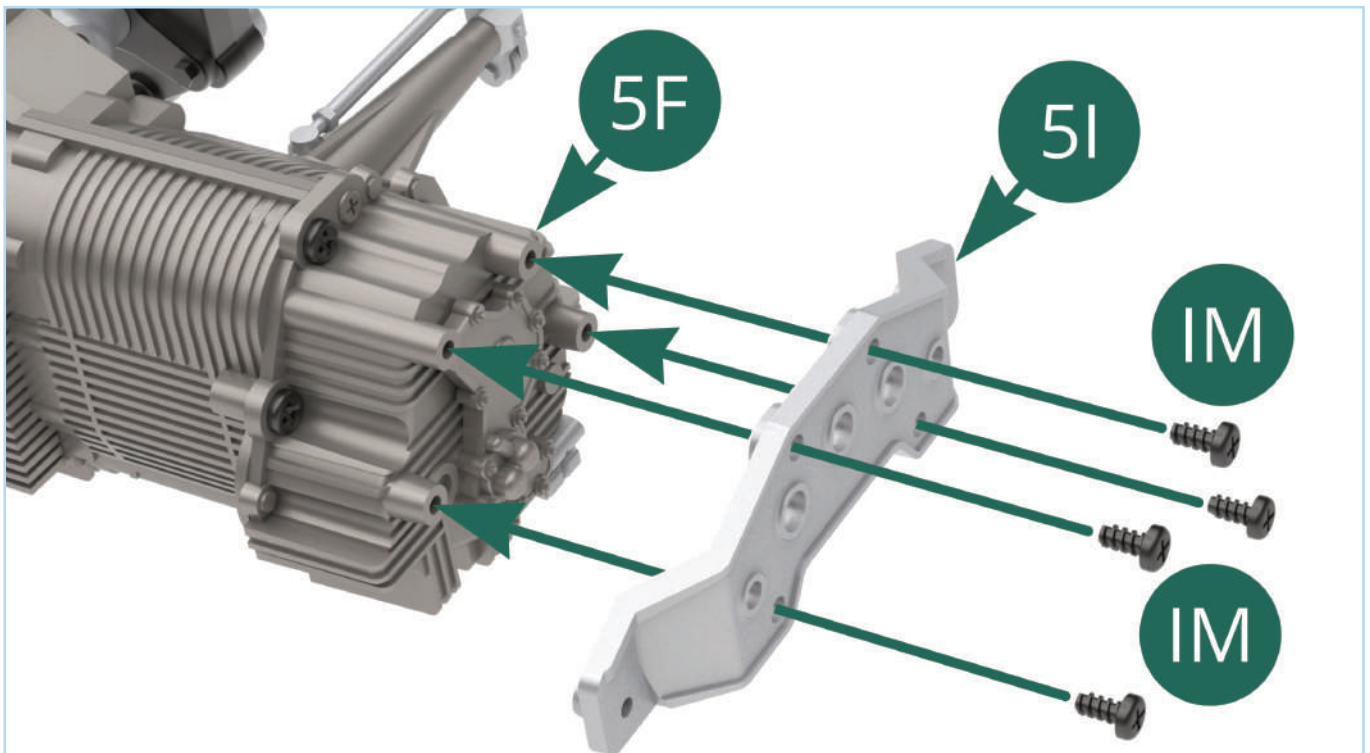

Next take the **exhaust pipe bracket (5I)** supplied in Stage 5 and fit it onto the **gearbox rear cover (5F)** as shown, then attach it using four **IM** screws.

STAGE 06: LEFT-SIDE OF GEARBOX AND TRANSMISSION JOINT

STAGE COMPLETE

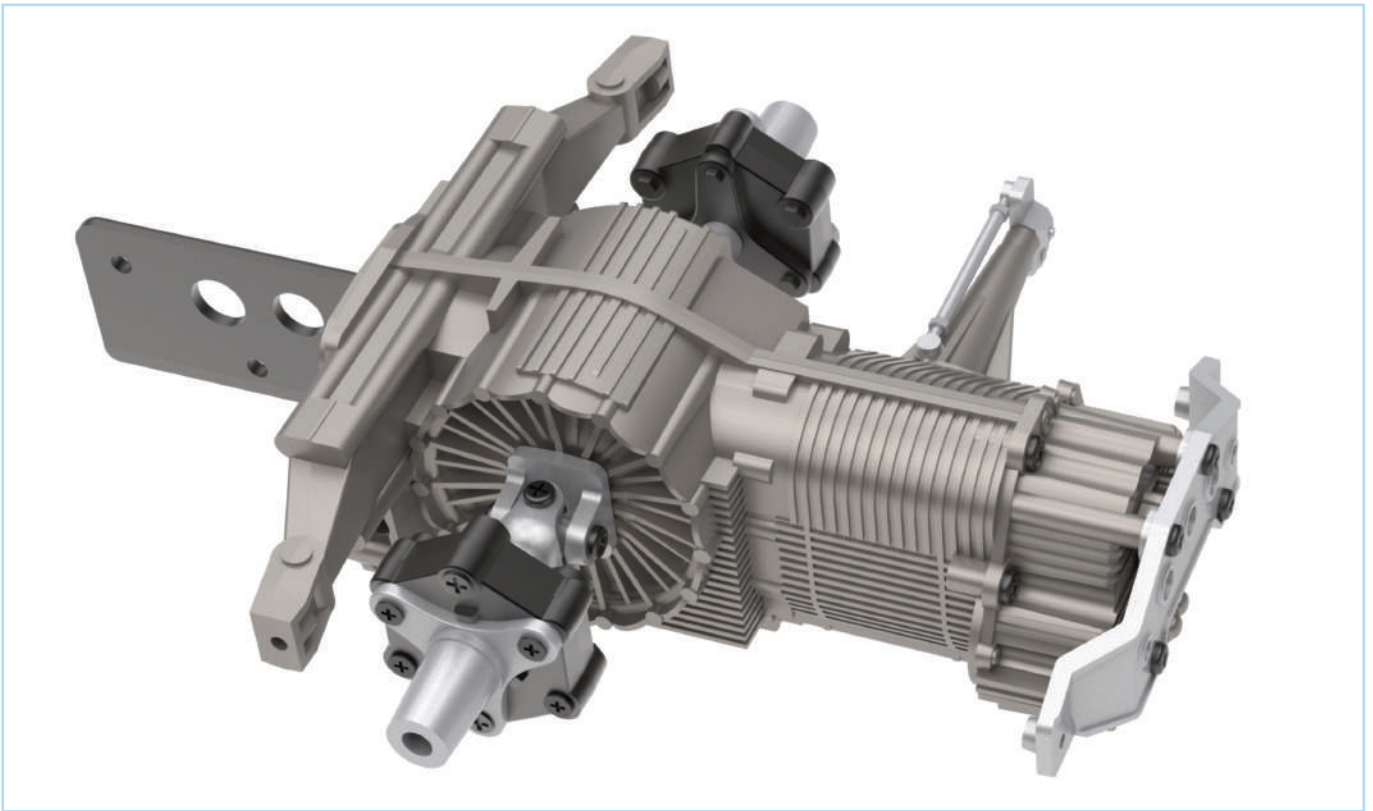

STAGE 07: RIGHT-SIDE OF ENGINE BLOCK

- 7A** Right engine block
- 7B** Camshaft gear housing
- 7C** Camshaft gear cover
- 7D** Cylinder top (x2)

- 7E** Cylinder bottom (x2)
- 7F** Linking bracket
- IM** Screw 1.7 x 3.5mm (x3)
- BM** Screw 2.0 x 4mm (x4)

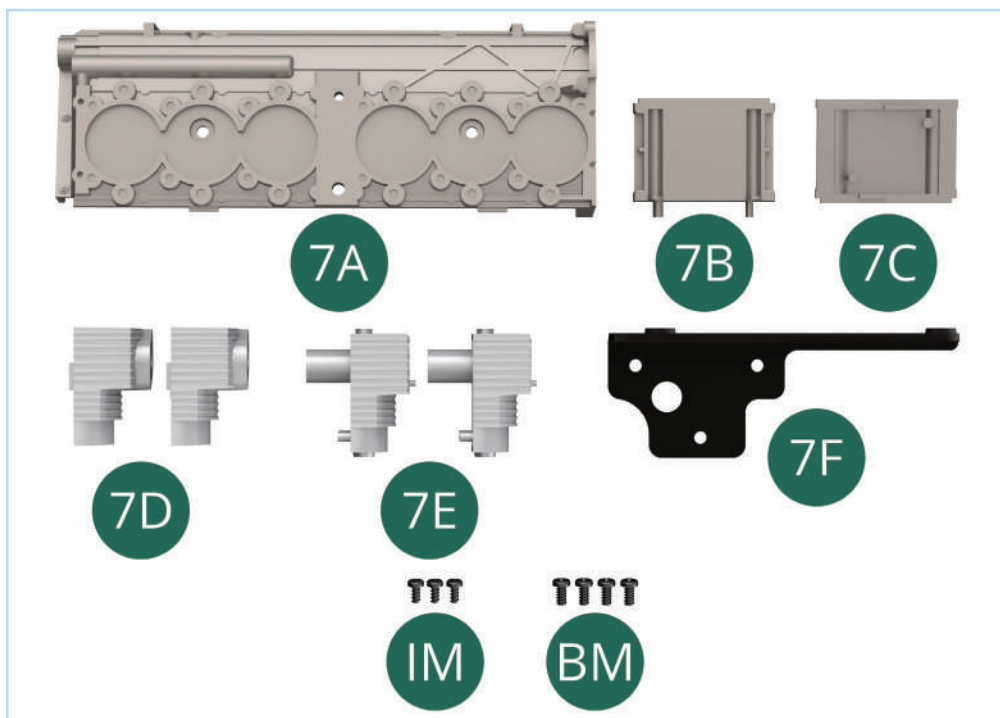

ASSEMBLY DIAGRAM

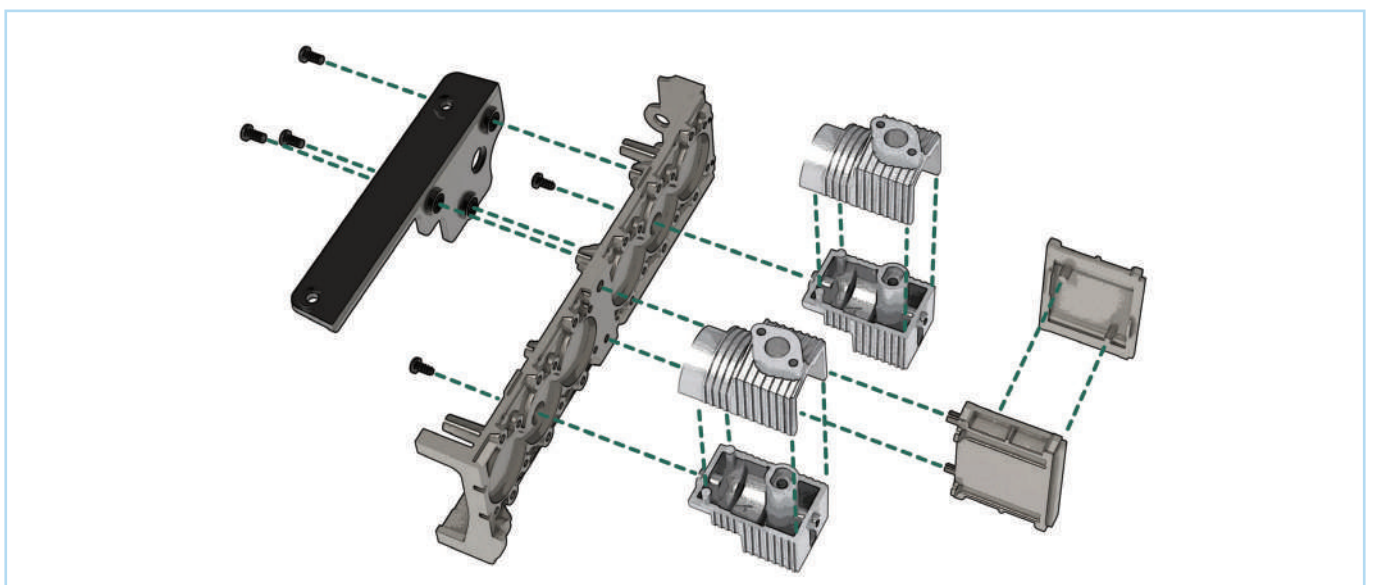

STAGE 07: RIGHT-SIDE OF ENGINE BLOCK

STEP 1

Fit the **cylinder tops (7D)** onto the **cylinder bottoms (7E)** to create two cylinders.

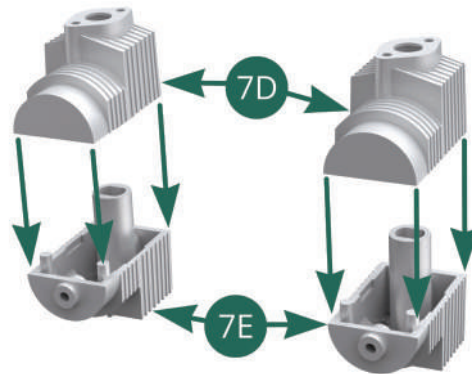

You may wish to super glue the cylinder parts to avoid splitting when securing them to the engine block.

Align the cylinders with the **right engine block (7A)** and secure them to the engine block by driving through two of the **IM** screws.

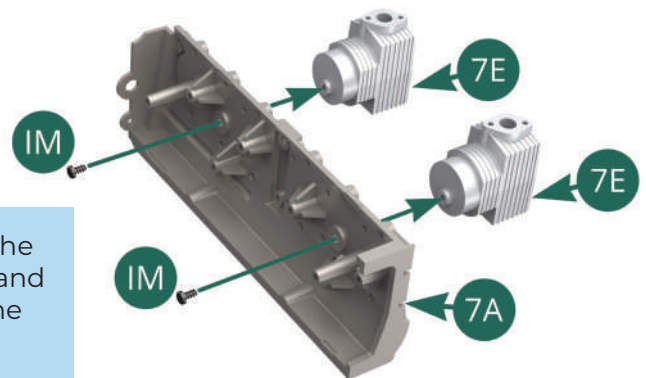

STEP 2

Fit the **linking bracket (7F)** onto the interior of the **right engine block (7A)** and fix in place with three **BM** screws as shown.

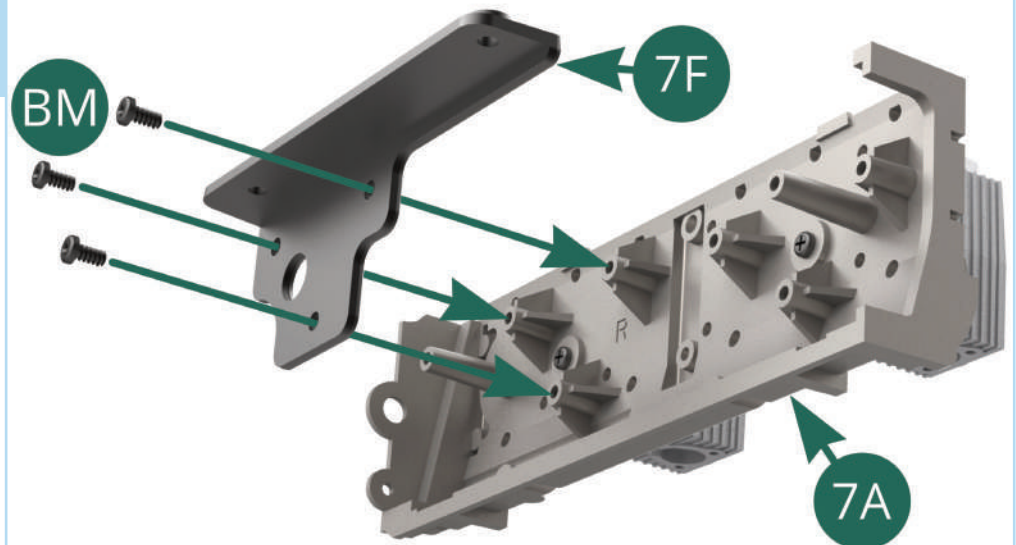

STAGE 07: RIGHT-SIDE OF ENGINE BLOCK

STEP 3

Press together the **camshaft gear housing (7B)** and **camshaft gear cover (7C)**, then fit it into the **right engine block (7A)** using the two pins on the housing as shown.

Note that one of the pins is larger than the other when fitting these parts together. You can use a little glue to stop them springing apart when fitting in place.

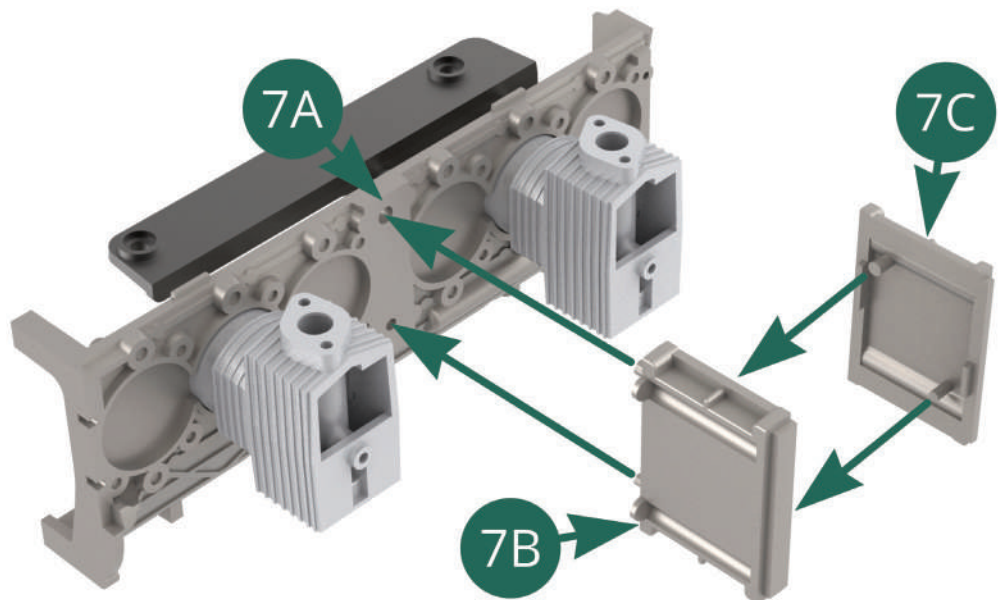

You may need to file excess paint off the camshaft gear box so that it fits flush with the engine block.

The camshaft gear box should look like this once in place on the engine block.

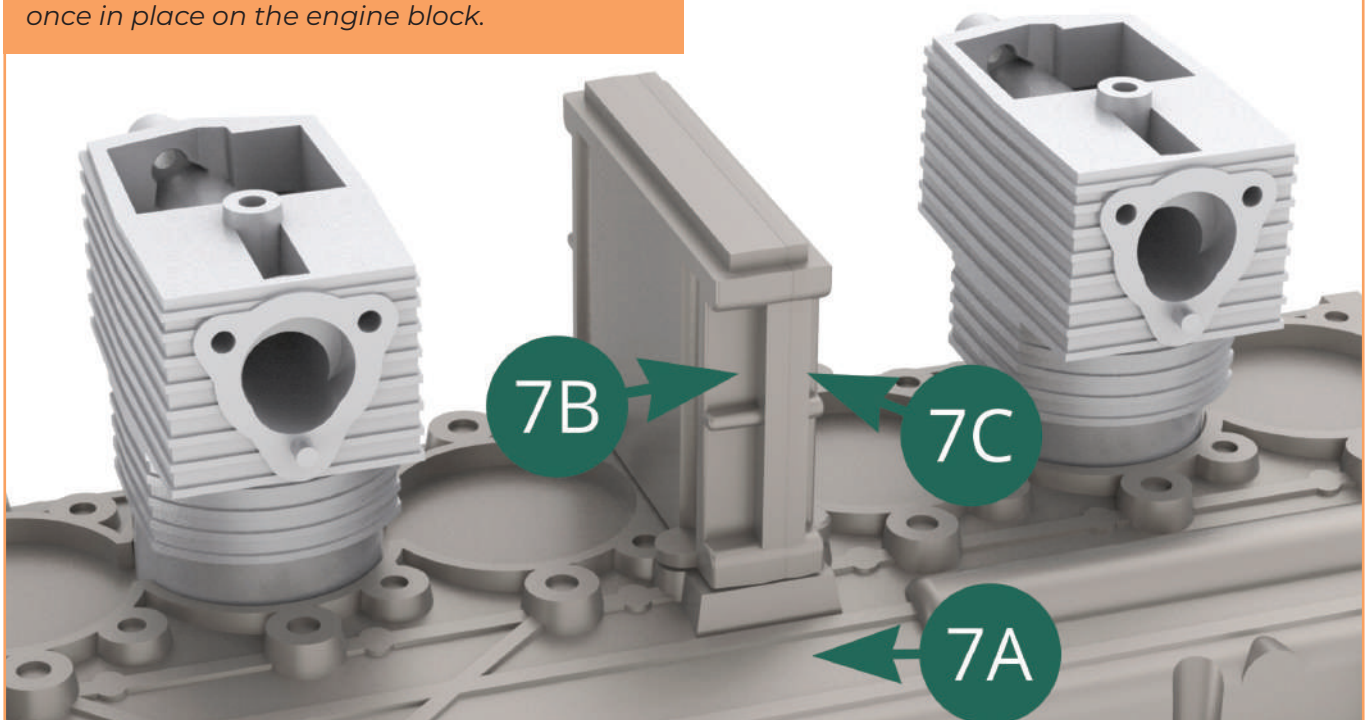

STAGE 07: RIGHT-SIDE OF ENGINE BLOCK

STAGE COMPLETE

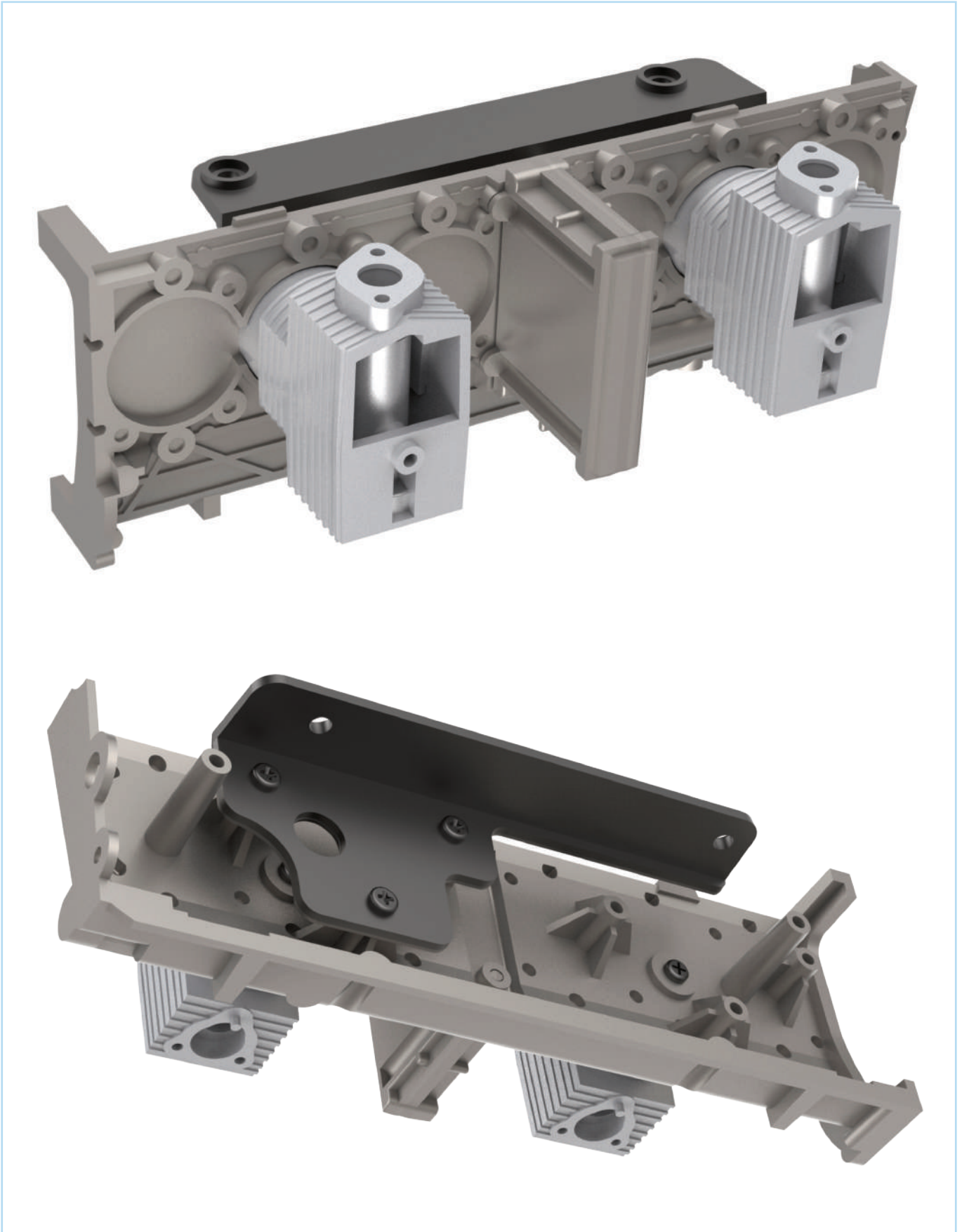

STAGE 08: PREPARING THE OIL PUMP AND CYLINDERS

8A Oil pump housing

8B Oil pump

8C Oil hose (x2)

8D Oil filter bracket

8E Oil filter cover

8F Cylinder top (x8)

8G Cylinder bottom (x8)

BM Screw 2.0 x 4mm (x4)

CM Screw 2.0 x 3 x 5mm (x2)

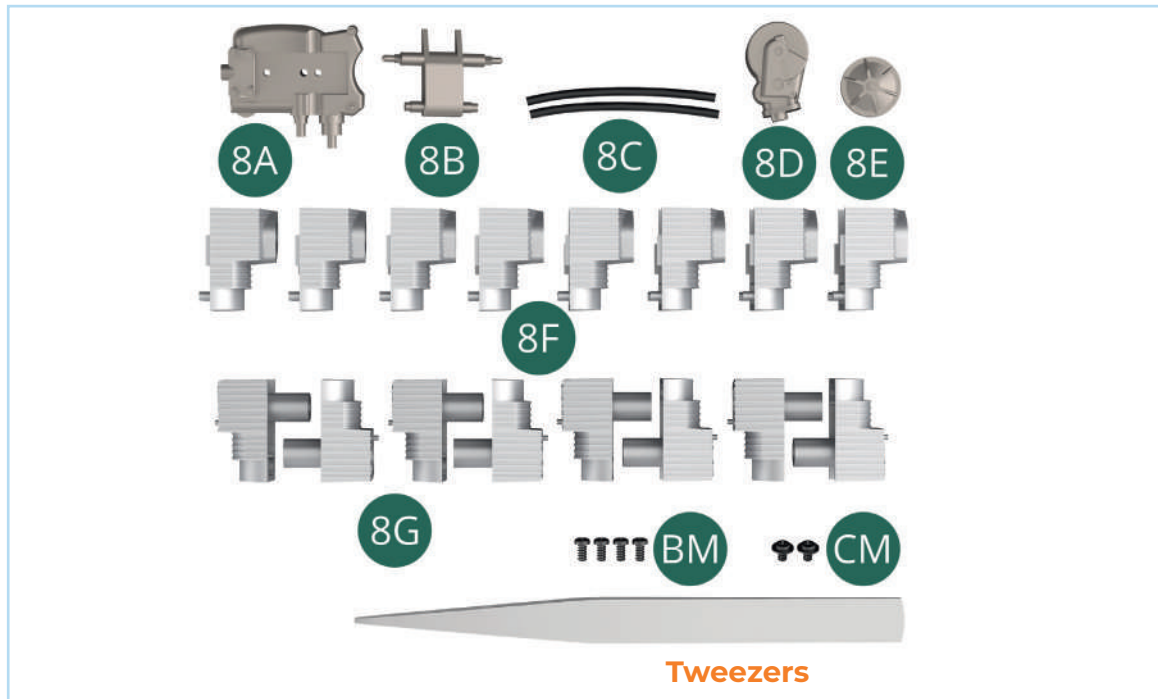

ASSEMBLY DIAGRAM

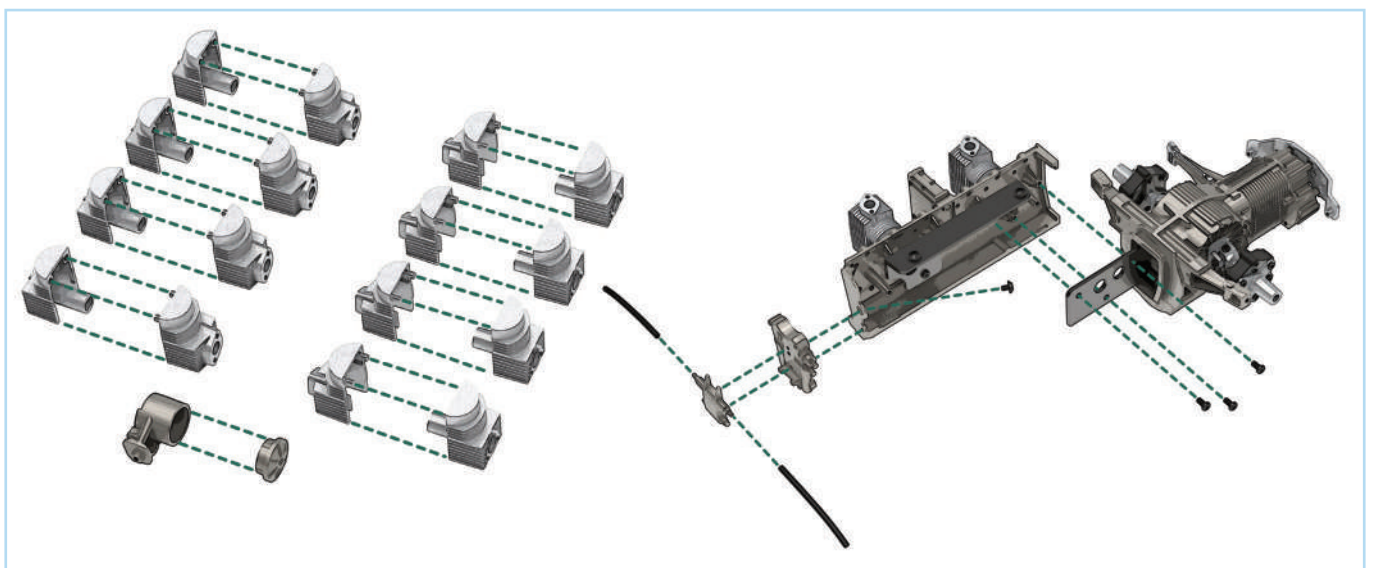

STAGE 08: PREPARING THE OIL PUMP AND CYLINDERS

STEP 1

Press the pins of the **cylinder tops (8F)** into the corresponding holes in the **cylinder bottoms (8G)** to create eight cylinders.

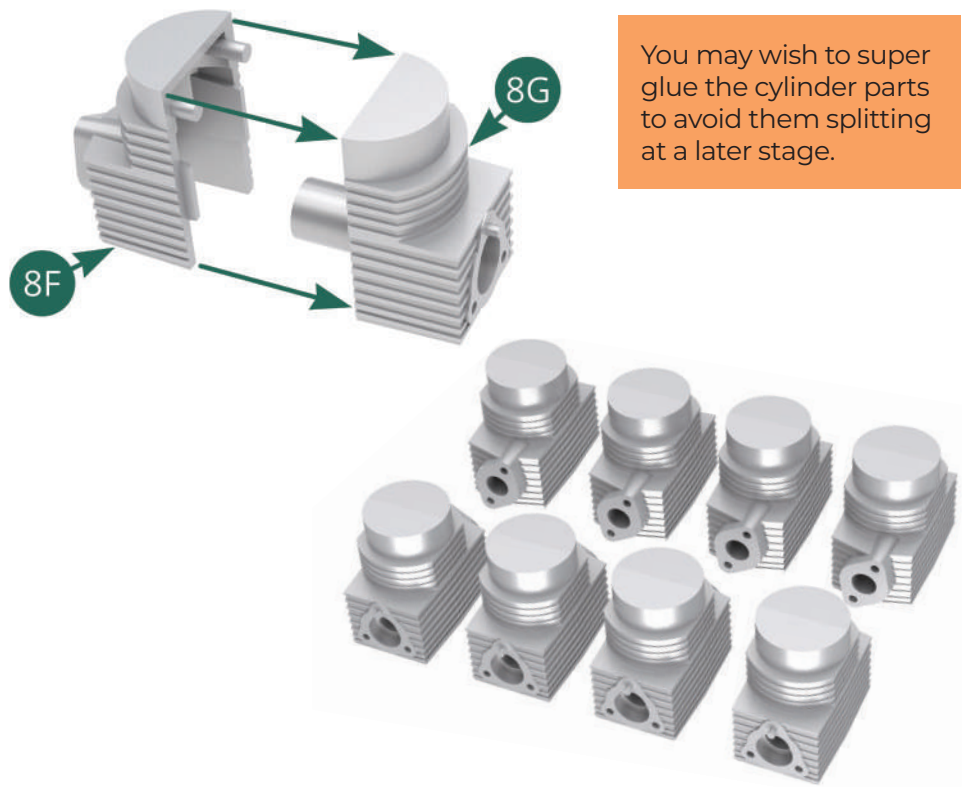

STEP 2

Push the **oil filter cover (8E)** into the **oil filter bracket (8D)**.

Take the two **oil hoses (8C)** and connect them to the lugs on the **oil pump (8B)**, then press the oil pump into the **oil pump housing (8A)**.

Tip: if the hoses are bent, try dipping them in hot water and bending them back to into shape.

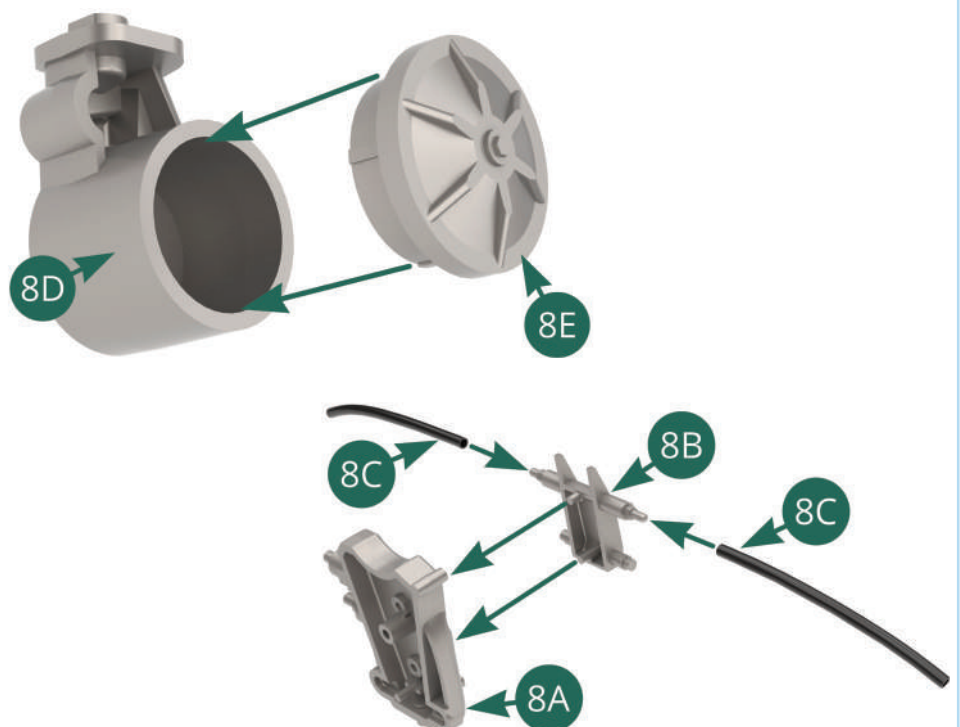

STAGE 08: PREPARING THE OIL PUMP AND CYLINDERS

STEP 3

Position the **oil pump housing (8A)** on the end of the **right engine block (7A)**. Press the housing firmly while securing it in place with a **CM** screw as shown.

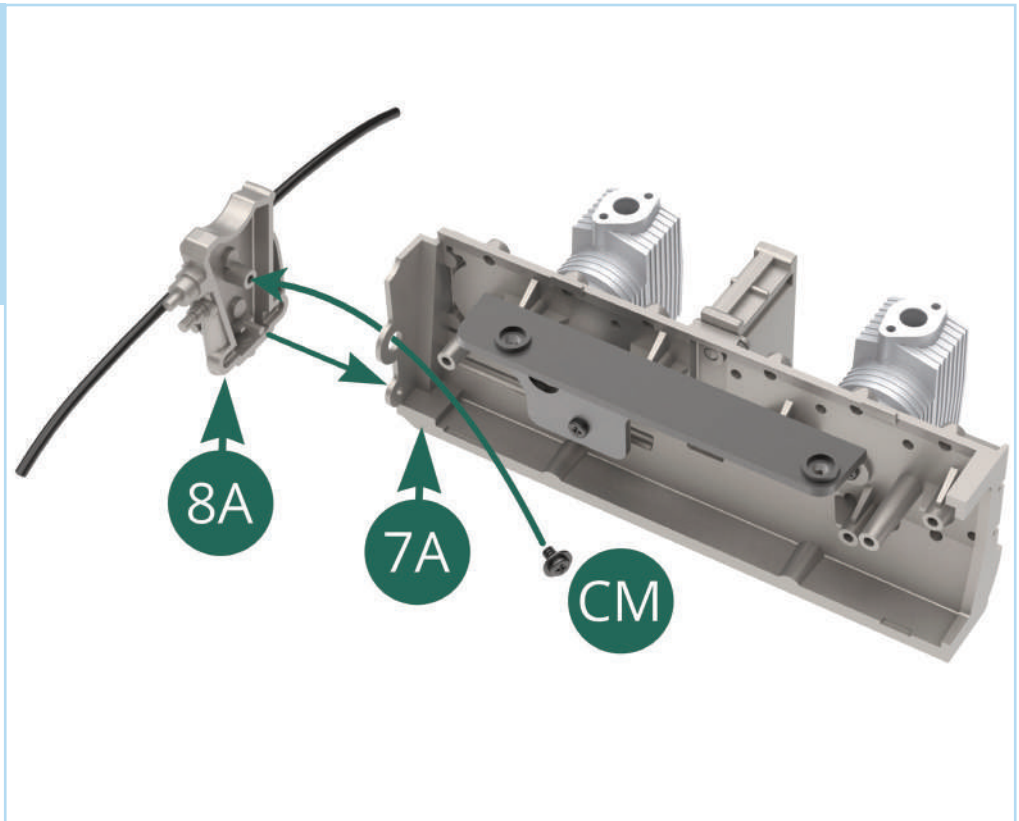

Press the **right engine block (7A)** firmly into the **internal support (5B)** of the gearbox assembly and attach with three **BM** screws.

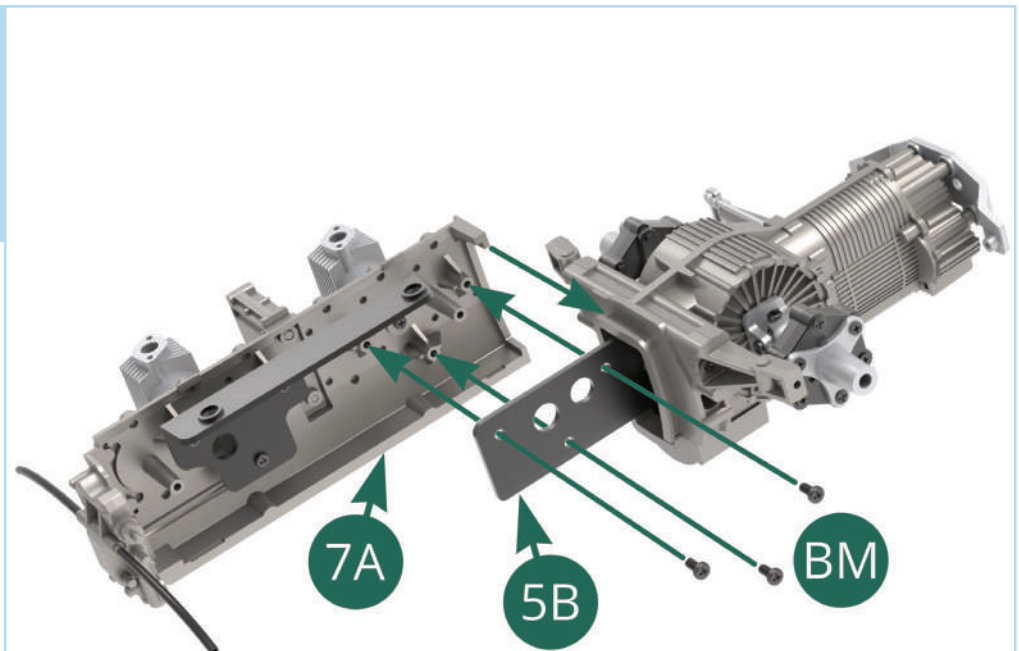

Make sure the two parts are pressed together tightly so that the connection is flush.

STAGE 08: PREPARING THE OIL PUMP AND CYLINDERS

The right engine block mounted on the gearbox assembly.

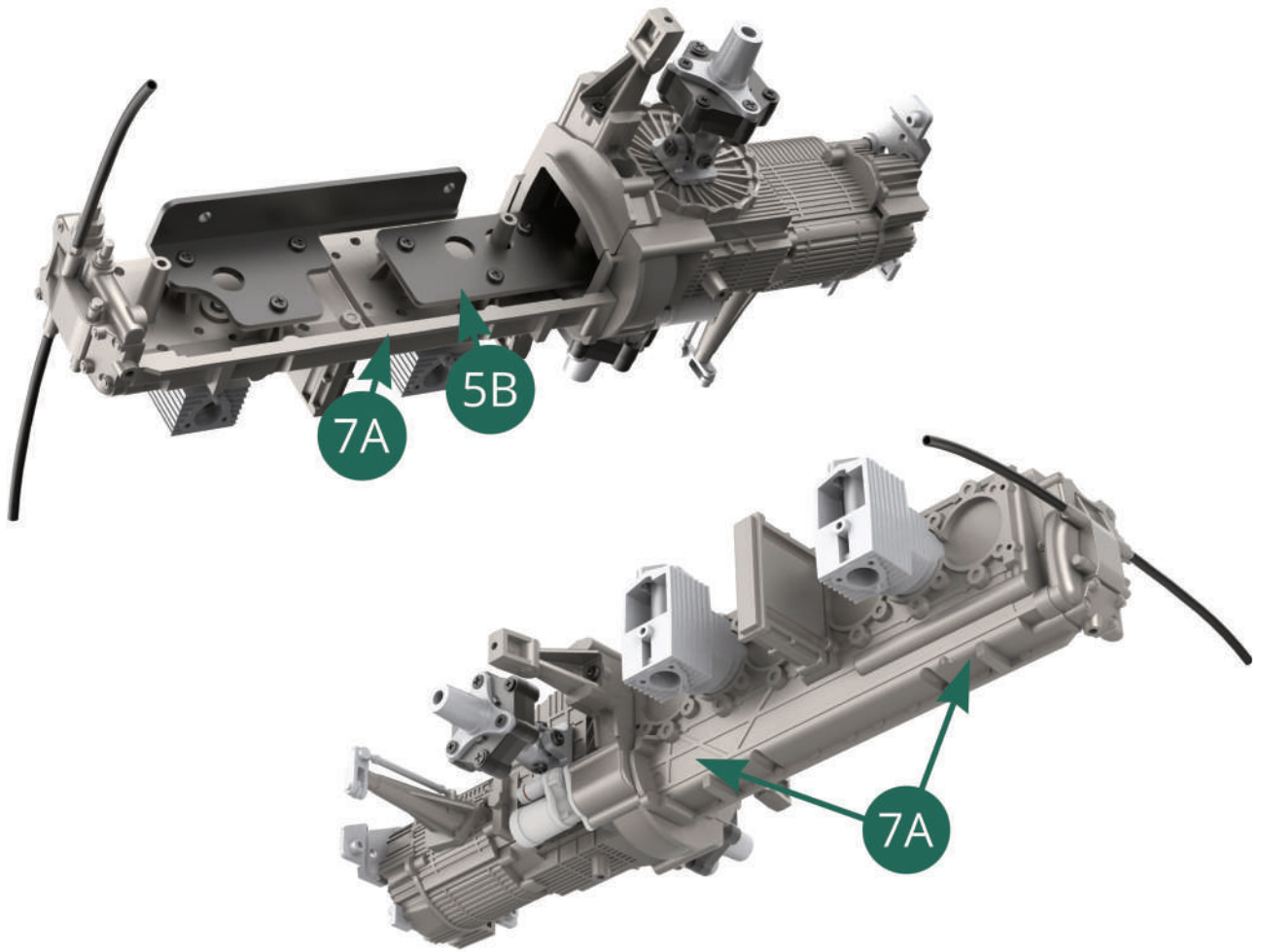

STAGE COMPLETE

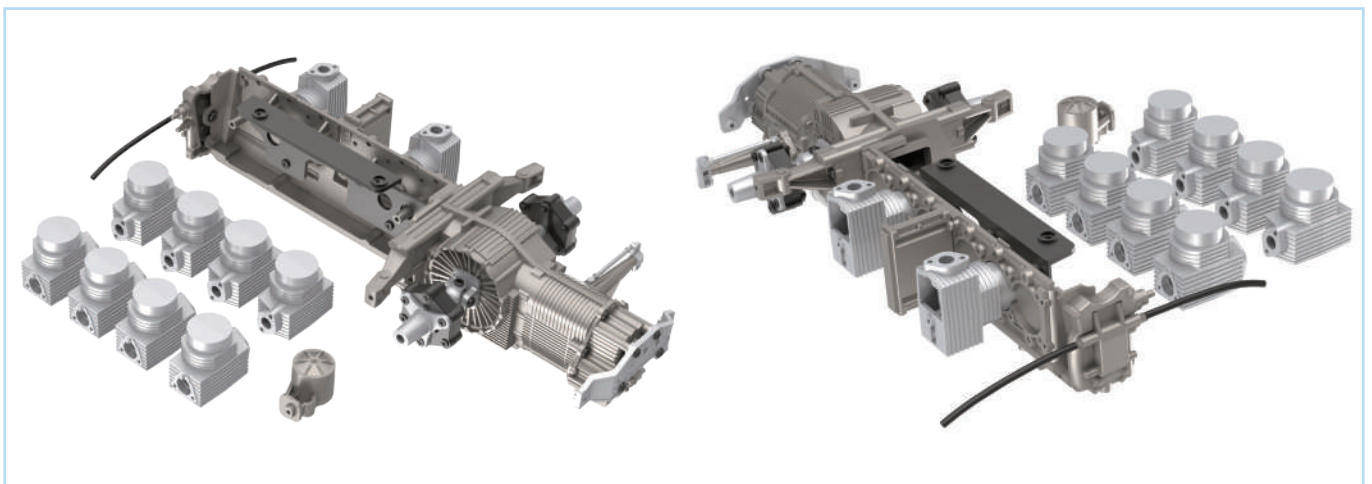

STAGE 09: ATTACHING THE RIGHT CYLINDER HEAD

9A Right cylinder head

9B Spark plugs (x12 + 6 spares)

9C Intake cam cover

9D Exhaust cam cover

9E End shield (x 2)

IM Screw 1.7 x 3.5mm (x3)

EP Screw 1.7 x 5mm (x5)

To differentiate the **intake cam cover (9C)** from the **exhaust cam cover (9D)**, note the appearance of the faces for each part.

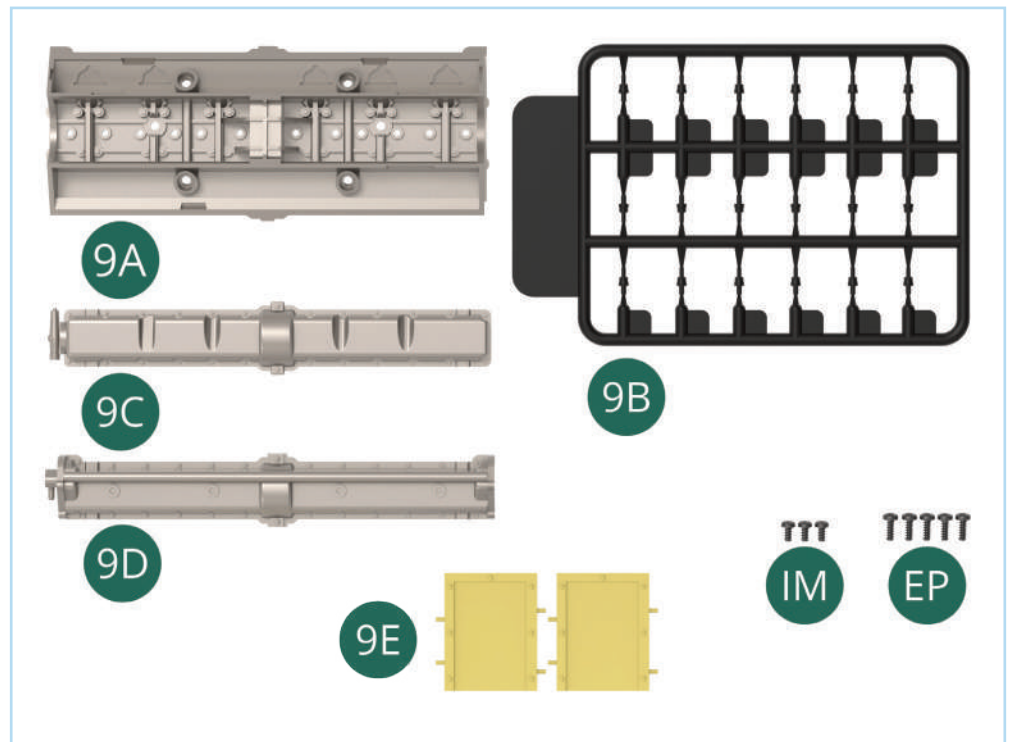

ASSEMBLY DIAGRAM

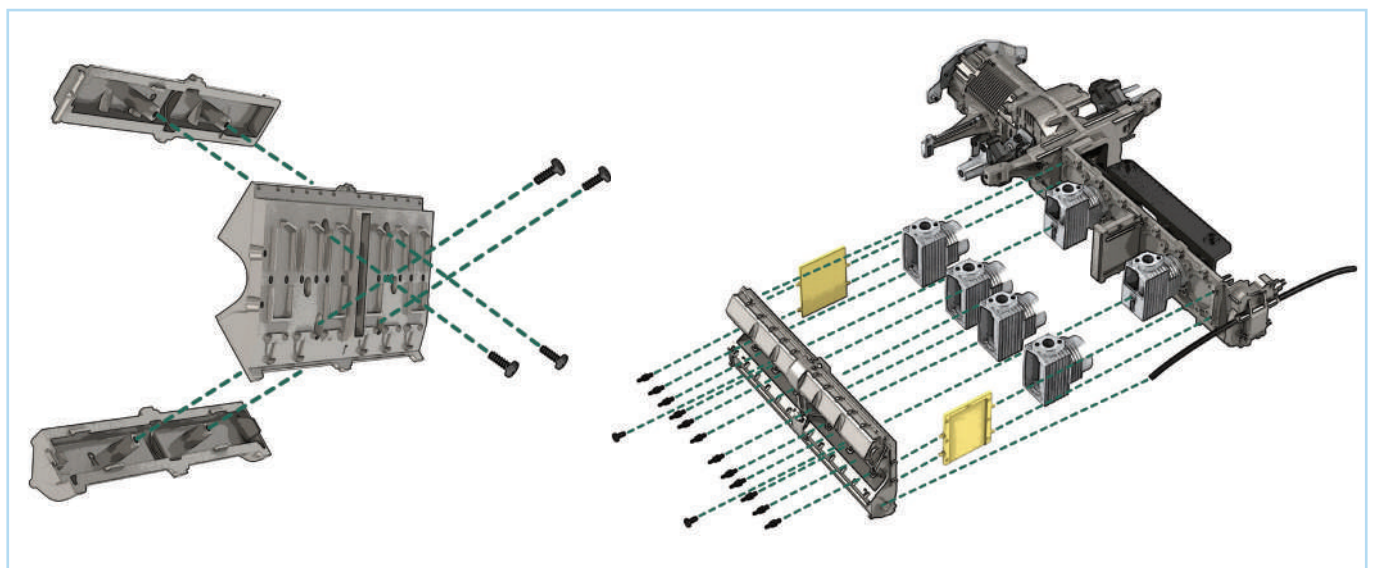

STAGE 09: ATTACHING THE RIGHT CYLINDER HEAD

STEP 1

Align the **right cylinder head (9A)** with the **exhaust cam cover (9D)** and fix the parts together with two **EP** screws.

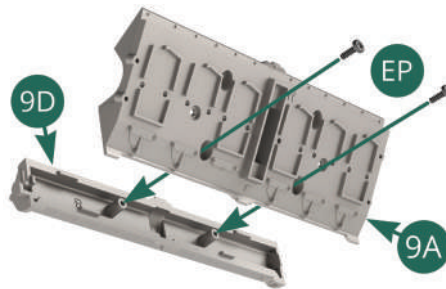

The two cam covers have different tabs to ensure they are fitted the right way round.

Push the **intake cam cover (9C)** onto the other side of the **right cylinder head (9A)** and secure with two **EP** screws.

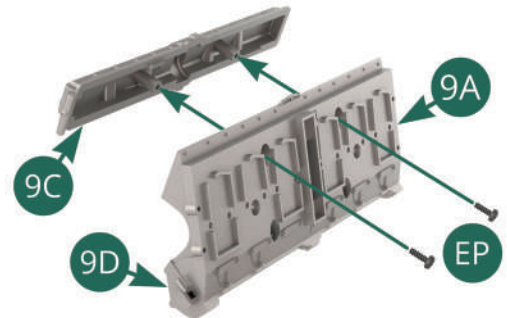

STEP 2

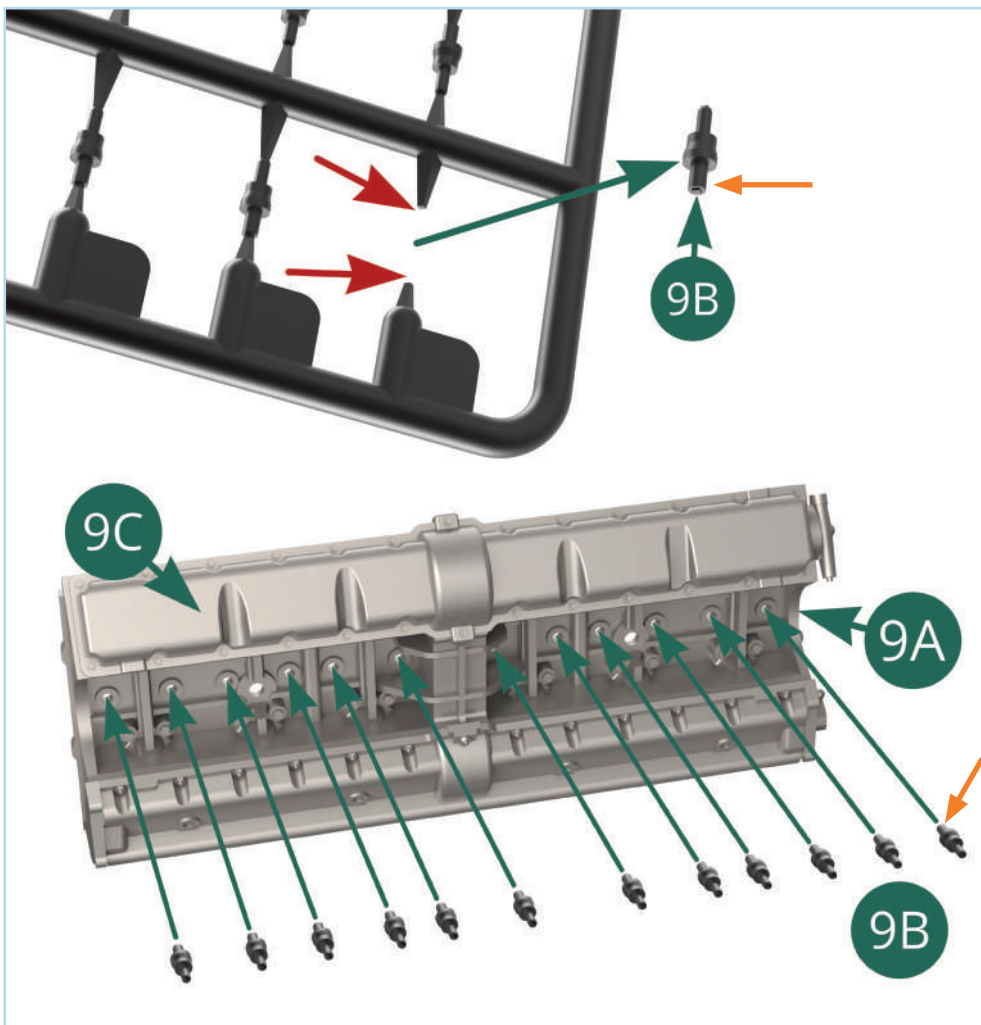

Remove twelve **spark plugs (9B)** from their frame at the points indicated with red arrows. Push them into the **right cylinder head (9A)** using the wider lug (orange arrows) as shown.

We recommend using a pair of sprue cutters for removing and a pair of tweezers for fitting these small parts. If any of the plugs are loose, use a small amount of super glue to hold it in place.

STAGE 09: ATTACHING THE RIGHT CYLINDER HEAD

The cam covers and spark plugs should look like this once fitted.

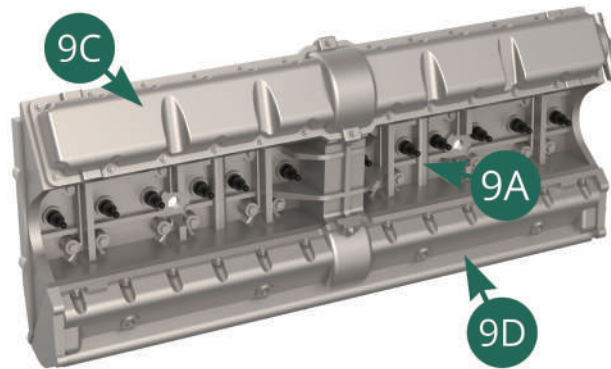

STEP 3

Push one of the **end shields (9E)** into the end of the **cylinder head (9A)** with the rivets facing outwards (red arrow).

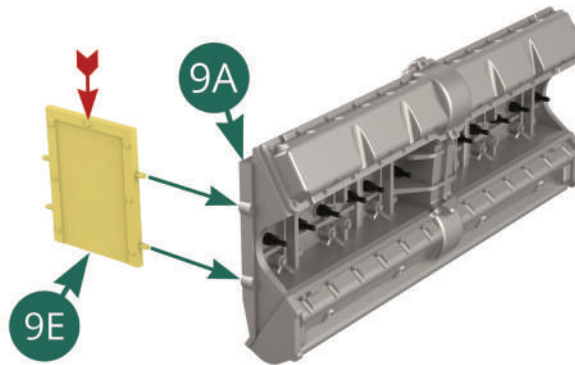

STEP 4

Push the remaining **end shield (9E)** into the opposite end of the **cylinder head (9A)**, with the rivets facing as shown (red arrow).

Next fit four of the cylinders assembled in the previous stage (**8F** and **8G**) onto the raised guides located on the **cylinder head (9A)**.

You can glue the end shields and cylinders in place if needed.

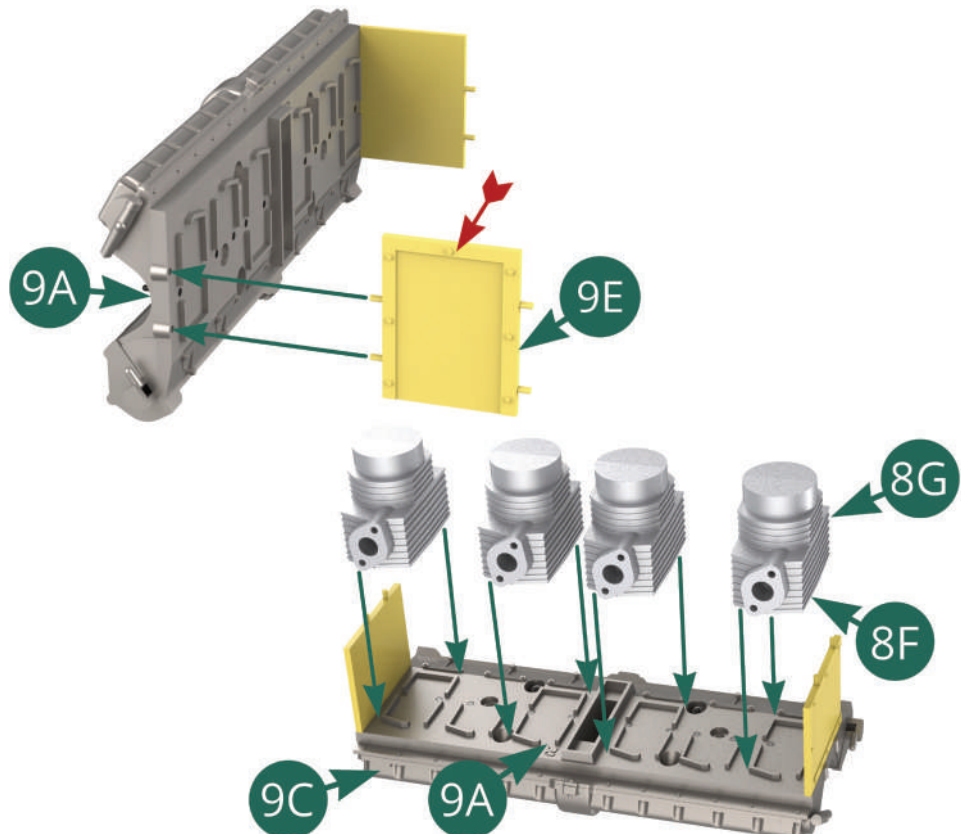

STAGE 09: ATTACHING THE RIGHT CYLINDER HEAD

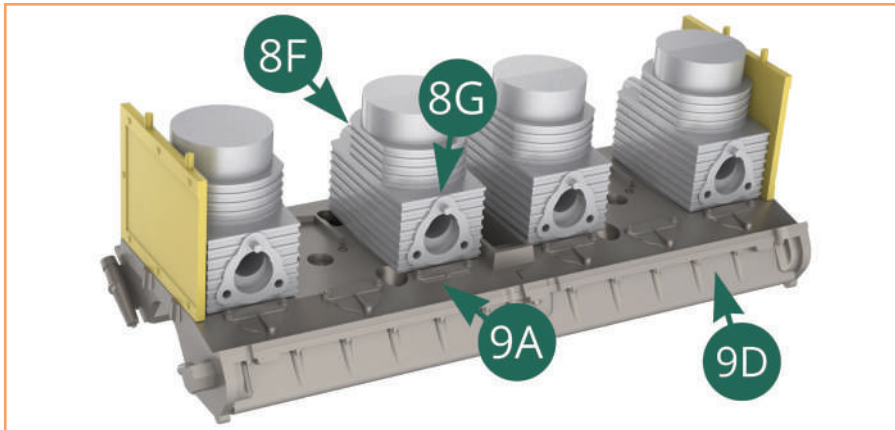

The cylinders and end shields should look like this once they have been fitted.

STEP 5

Align the cylinder head assembly with the **right engine block (7A)** as shown. Carefully fit in place, ensuring that the lugs from the two **end shields (9E)** fit into the corresponding holes and that the screw holes from the cylinder head assembly align with the screw holes in the **lower cylinders (7E)**. Attach the two assemblies together with two **IM** screws.

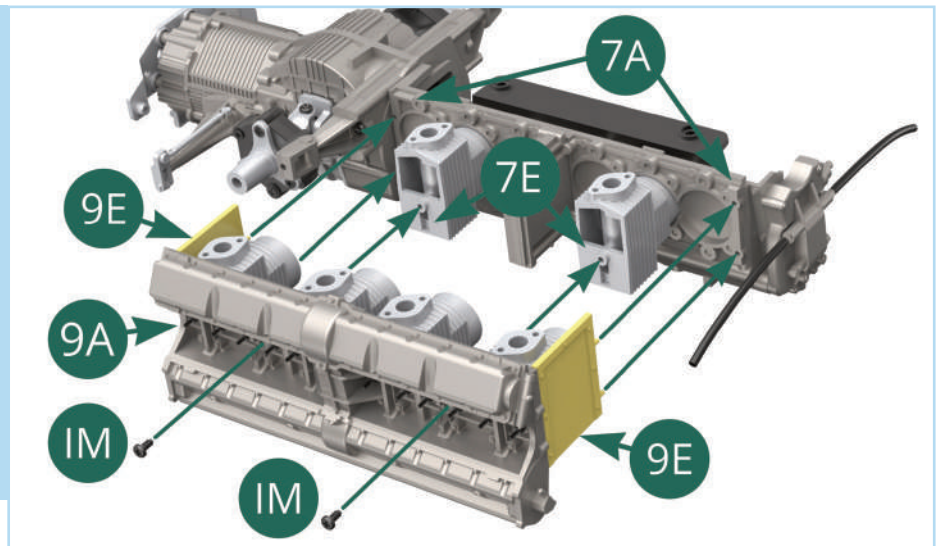

STEP 6

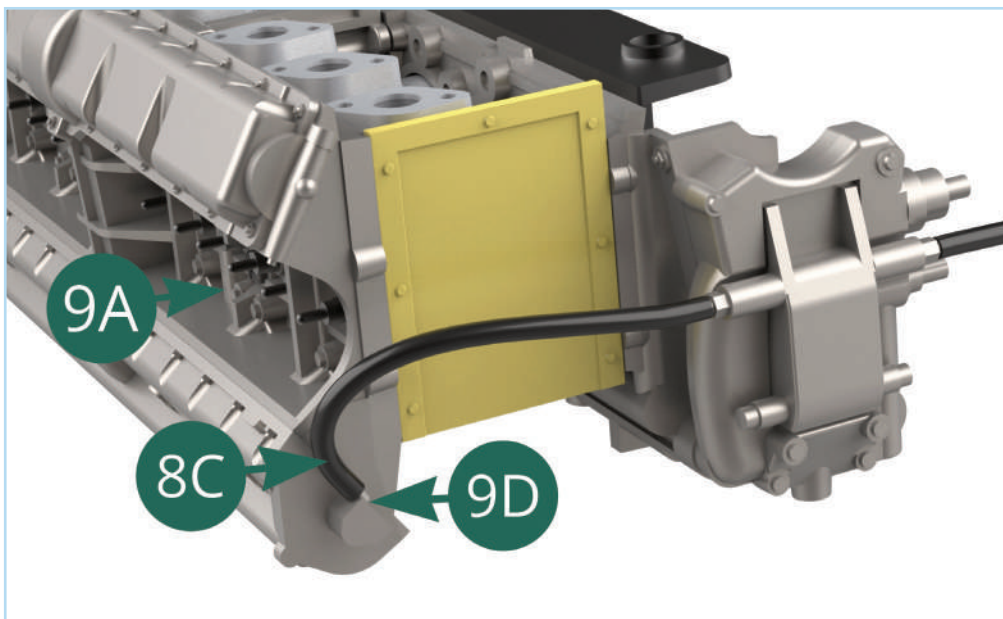

Connect the loose end of the **oil hose (8C)** on the engine block onto the lug at the end of the **exhaust cam cover (9D)** as shown.

If necessary, you can glue the hose in place with a small amount of super glue.

STAGE 09: ATTACHING THE RIGHT CYLINDER HEAD

STAGE COMPLETE

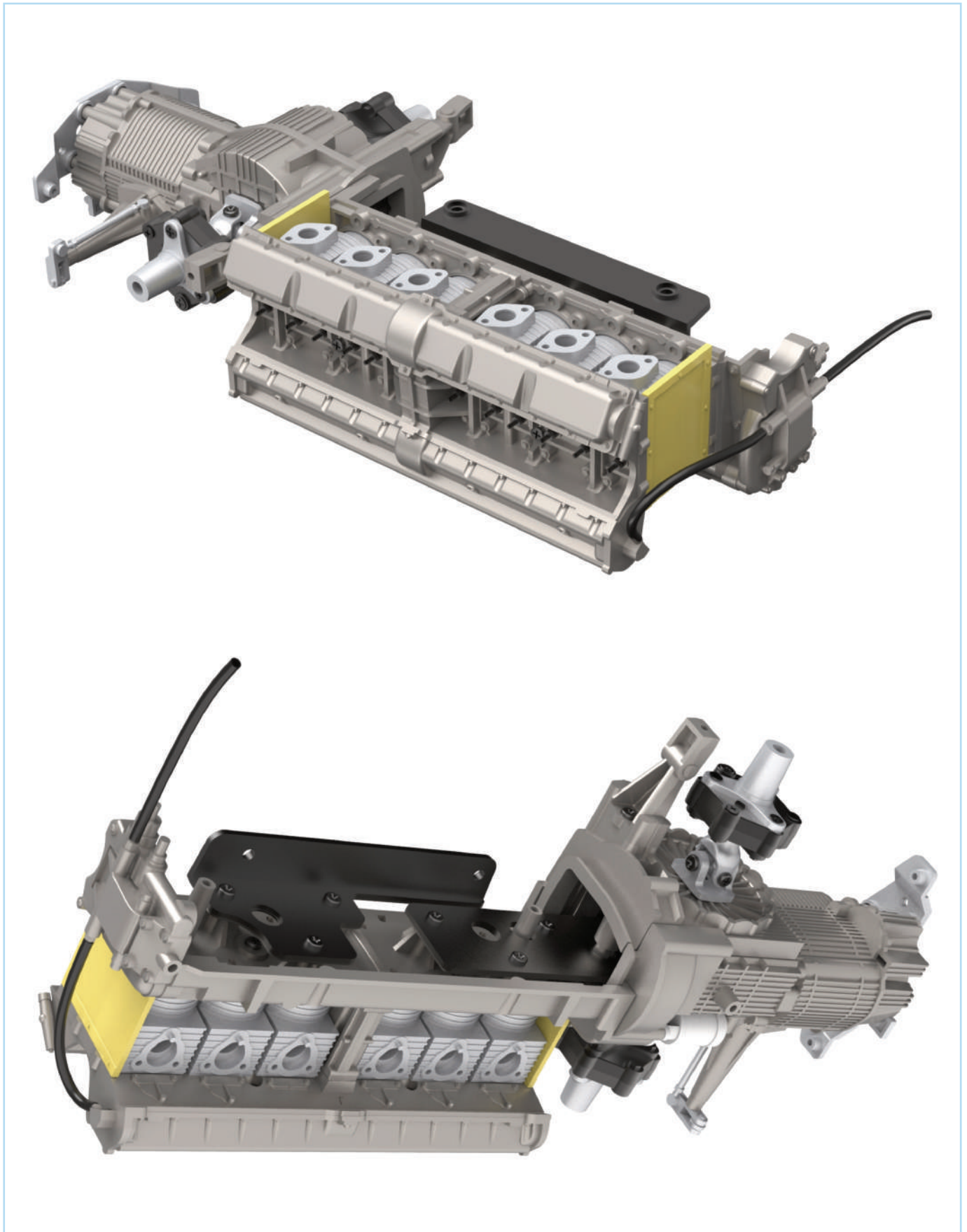

STAGE 10: ASSEMBLE AND FIT THE CRANKCASE TOP

10A Crankcase top

10B Large pulley front

10C Large pulley back

10D Alternator (x2)

10E Front cover and shaft (x2)

10F Small pulley front (x2)

10G Small pulley back (x2)

10H Distributor base (x2)

BM Screw 2.0 x 4mm (x3)

KM Screw 1.7 x 3 x 5mm (x2)

DP Screw 1.7 x 3 x 5mm (x3)

EP Screw 1.7 x 5mm (x6)

AP Screw 1.7 x 4mm (x2)

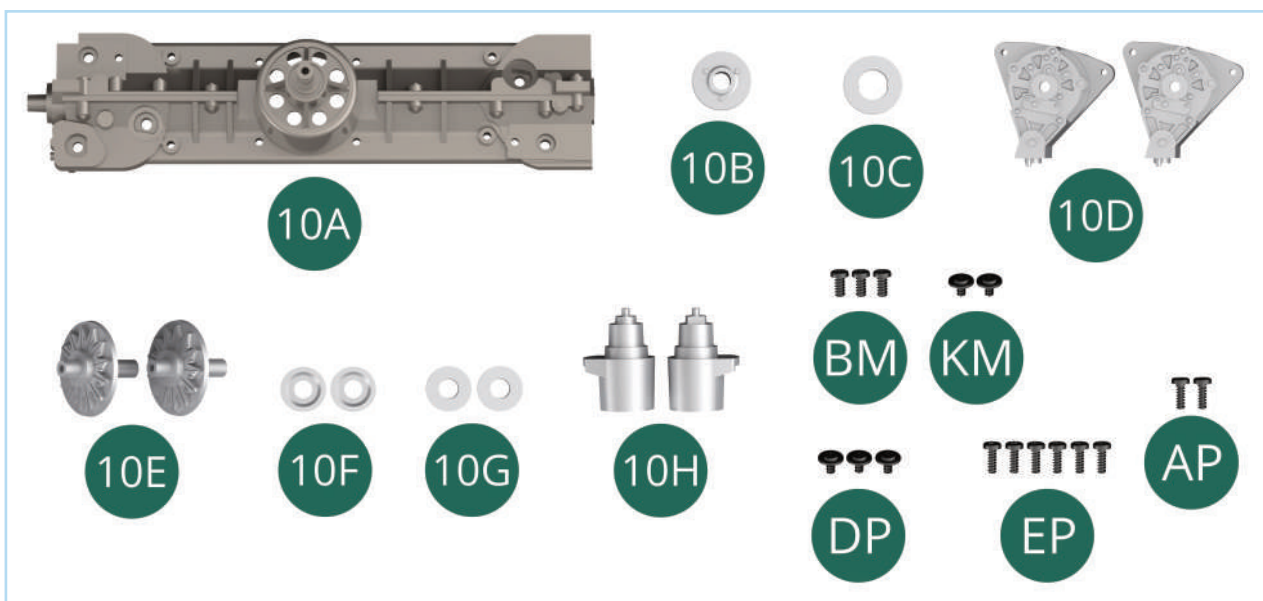

ASSEMBLY DIAGRAM

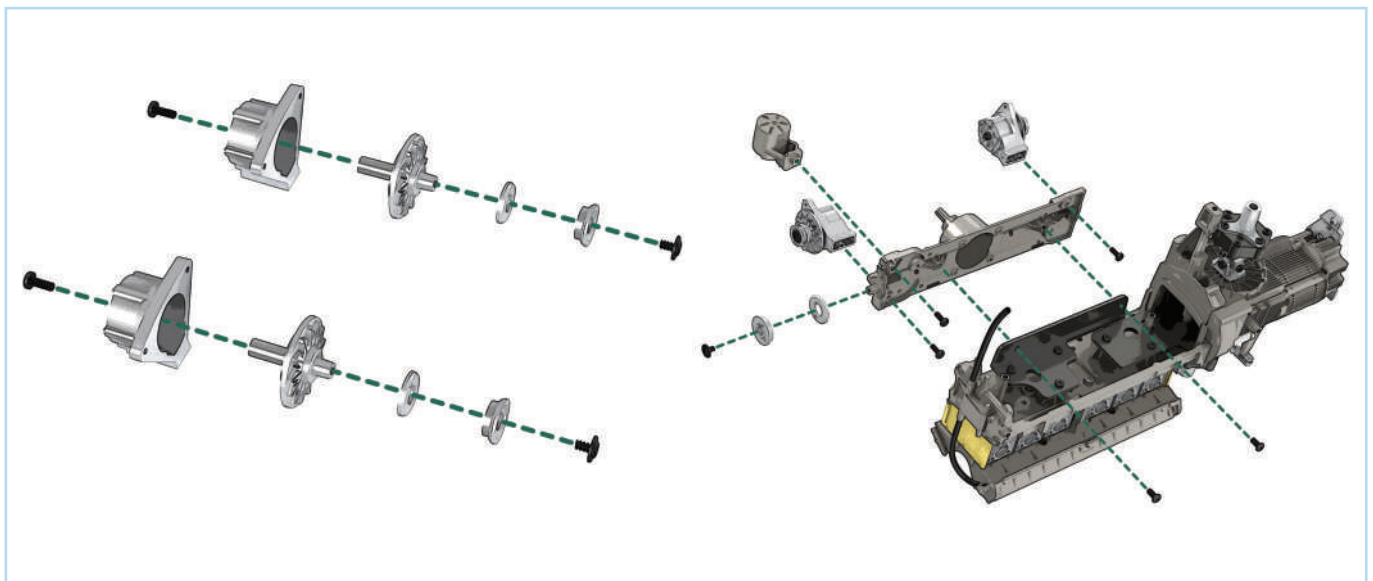

STAGE 10: ASSEMBLE AND FIT THE CRANKCASE TOP

STEP 1

Place a **small pulley back (10G)** over the short shaft of a **front cover and shaft (10E)**, followed by a **small pulley front (10F)**. Fix the parts together with a **DP** screw, then fit the assembly into the **alternator (10D)** and secure in place by driving an **EP** screw through the alternator.

Repeat this process to build a second alternator assembly.

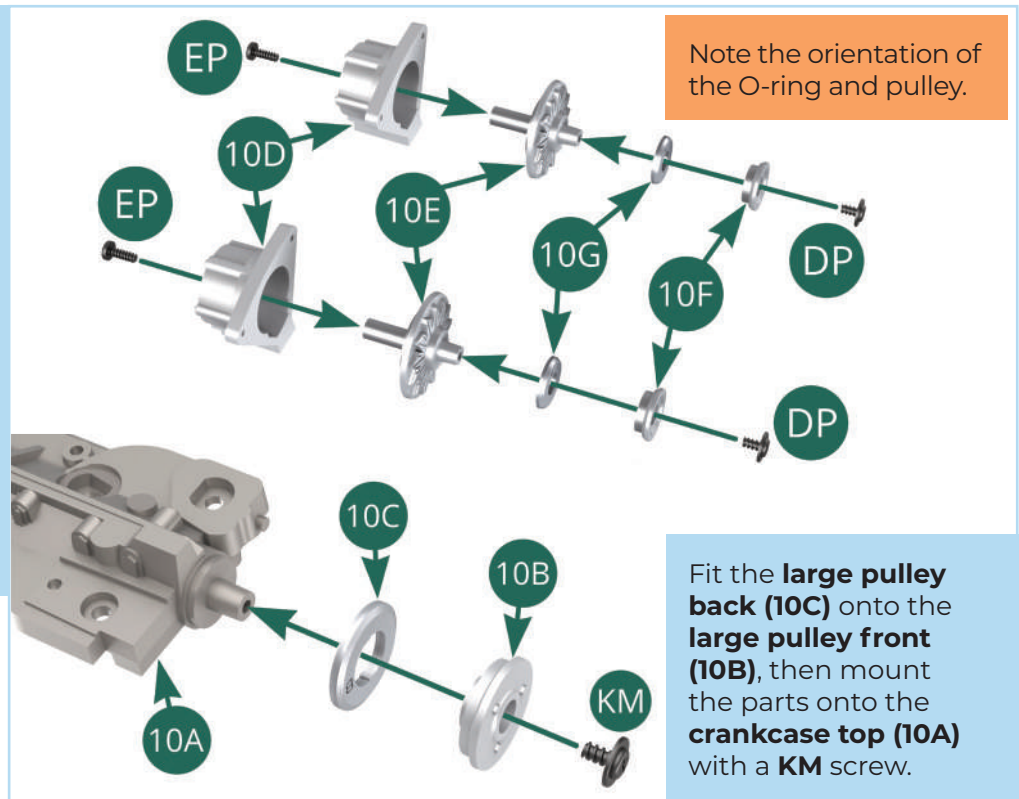

STEP 2

Align one of the alternators with the end of the **crankcase top (10A)** as shown. Using the pin and screw hole on the alternator as a guide, fit and secure it to the crankcase with an **EP** screw.

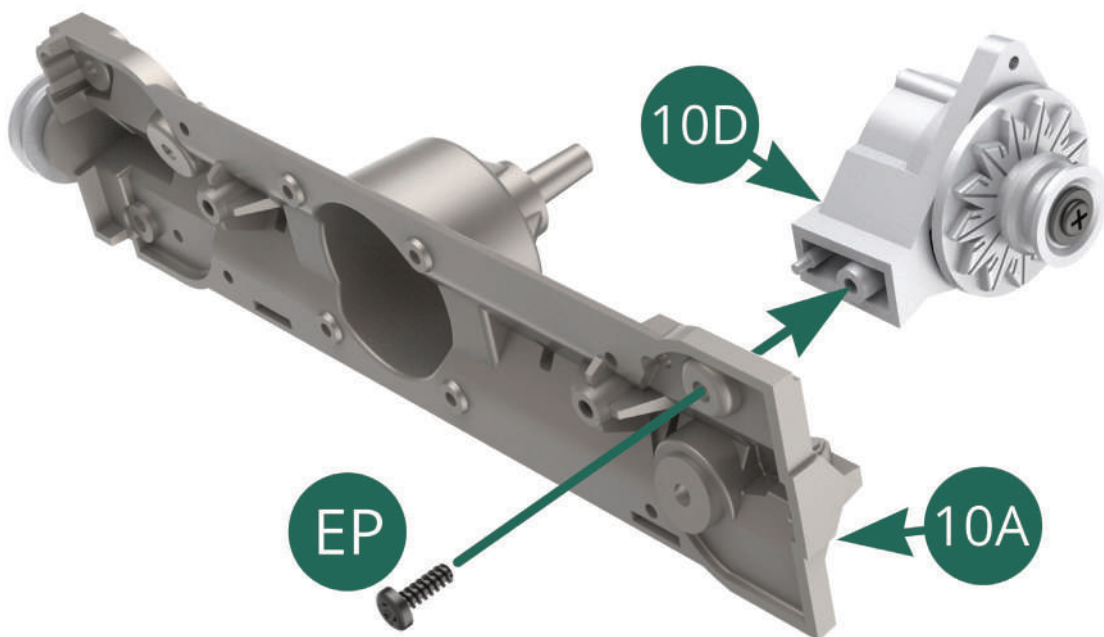

STAGE 10: ASSEMBLE AND FIT THE CRANKCASE TOP

The second alternator fits at the other end of the crankcase top in the same way. Drive an **EP** screw through to attach it.

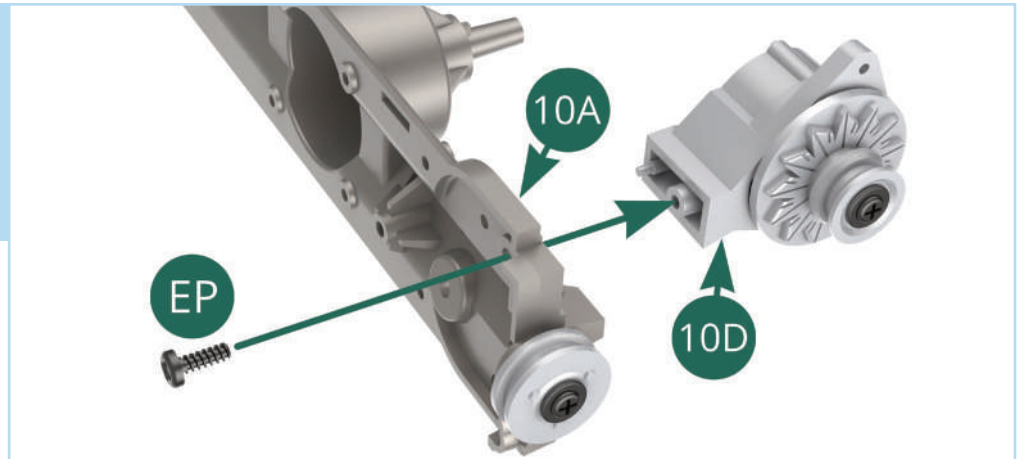

STEP 3

Using the D-shaped plug as a guide, add the **oil filter (8D)** from Stage 8 onto the crankcase above the pulley. Secure in place with an **AP** screw.

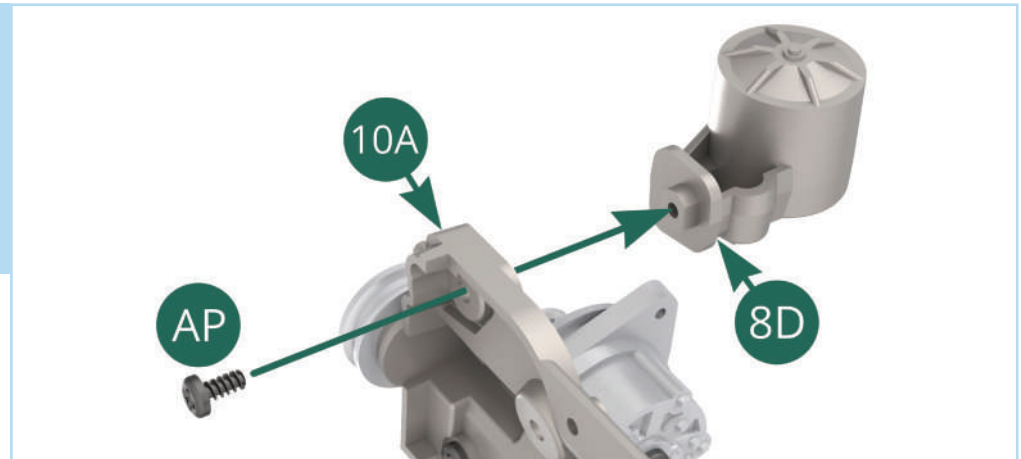

Position the crankcase top onto the **linking bracket (7F)** of the engine block assembly then drive two **BM** screws through as shown.

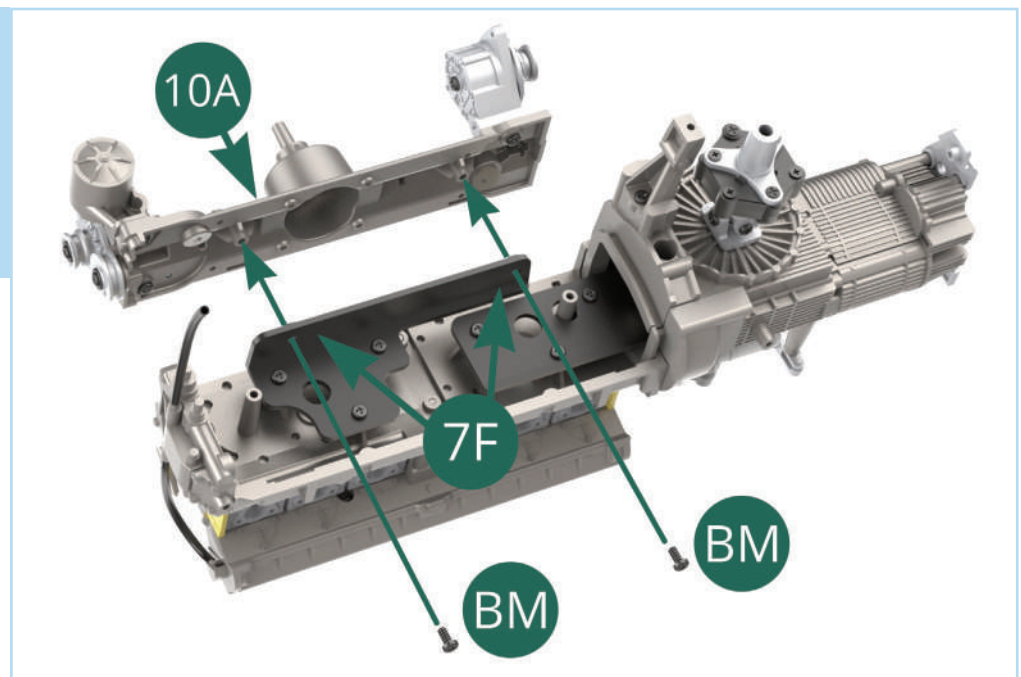

STAGE 10: ASSEMBLE AND FIT THE CRANKCASE TOP

STAGE COMPLETE

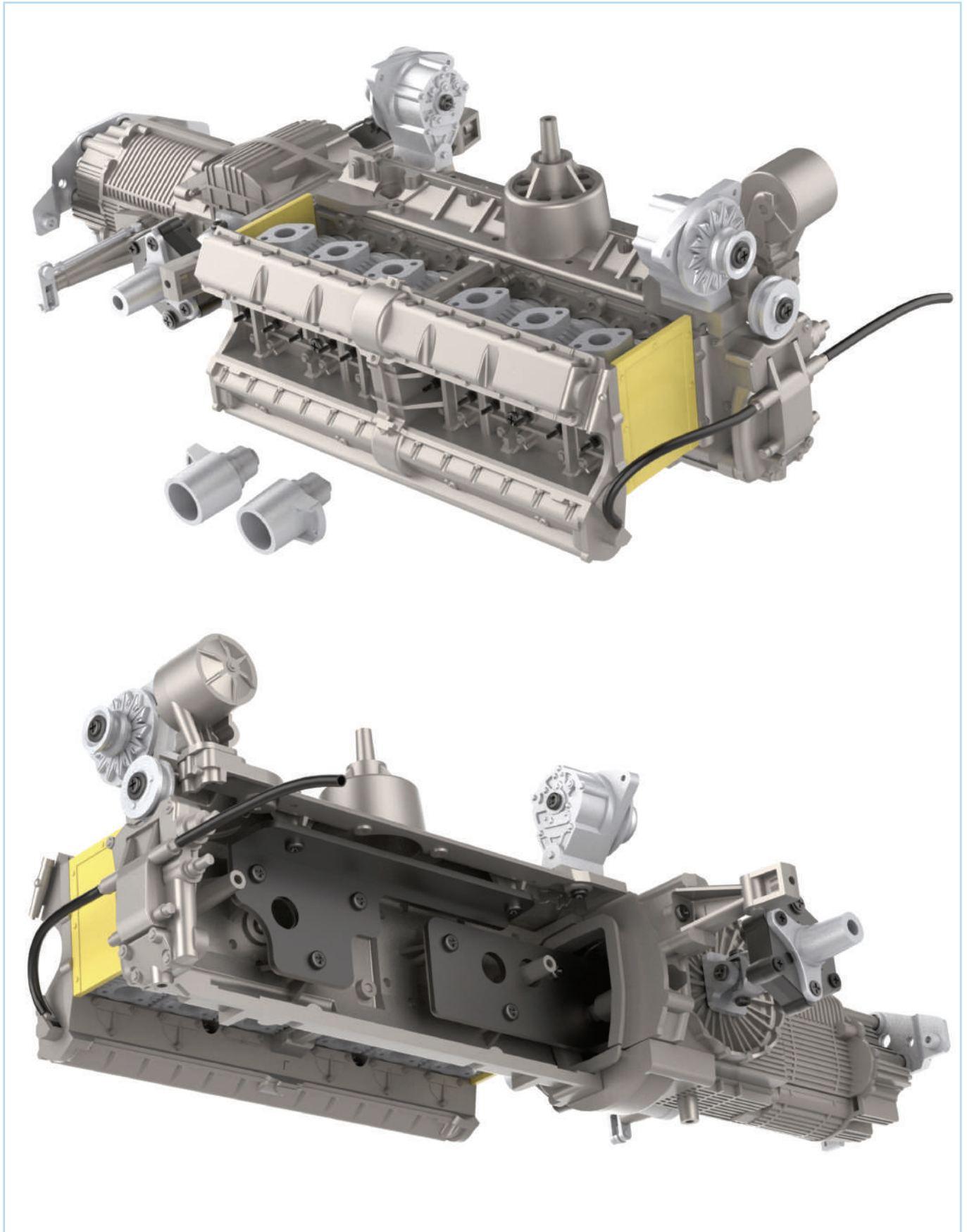

STAGE 11: LEFT-SIDE OF ENGINE BLOCK

11A Left engine block

11B Camshaft gear housing

11C Camshaft gear cover

11D Cylinder top (x2)

11E Cylinder bottom (x2)

IM Screw 1.7 x 3.5mm (x3)

JM Screw 2.0 x 5mm (x3)

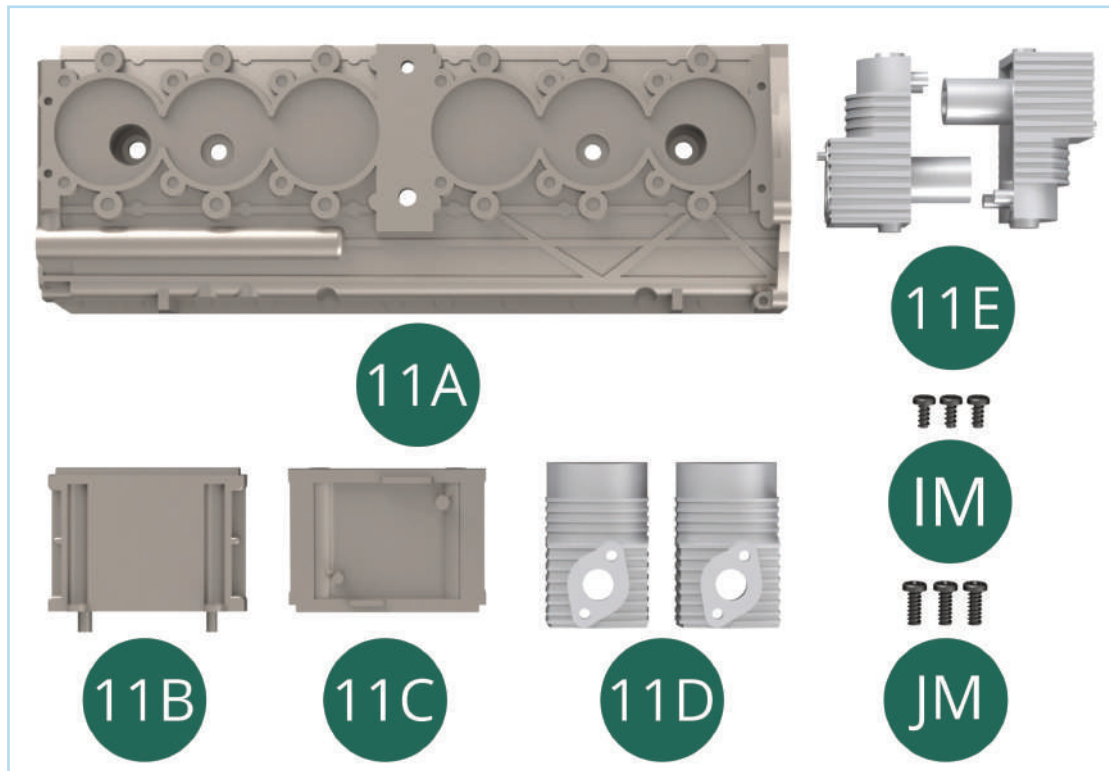

ASSEMBLY DIAGRAM

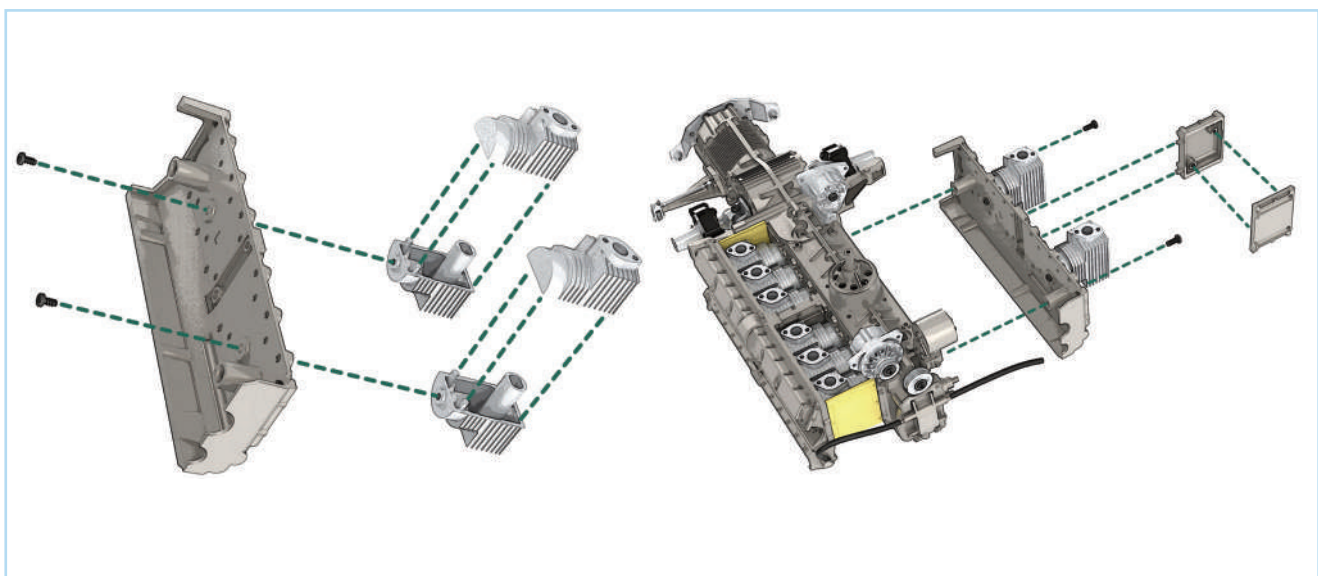

STAGE 11: LEFT-SIDE OF ENGINE BLOCK

STEP 1

Press the pins of the **cylinder bottoms (11E)** into the corresponding holes in the **cylinder tops (11D)** to create two cylinders.

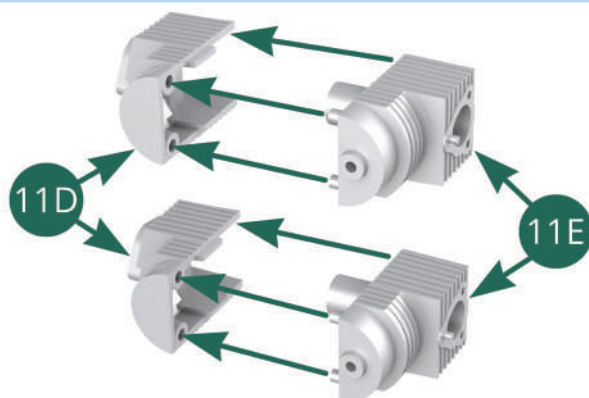

You may wish to super glue the cylinder parts to avoid splitting when fixing them in place.

Align the two cylinders with the **left engine block (11A)** and fix them in place by driving two **IM** screws through the engine block.

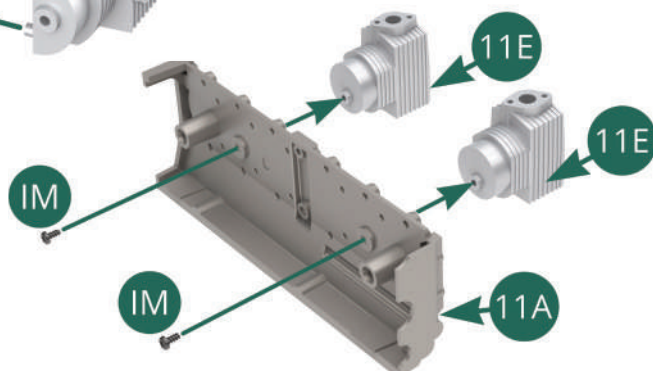

STEP 2

Fit the **camshaft gear cover (11C)** onto the **camshaft gear housing (11B)** by pressing the small and large pins into the corresponding holes (blue arrows). Then push the assembled camshaft gear box into the engine block, so that the small and large pins fit into the corresponding holes as shown.

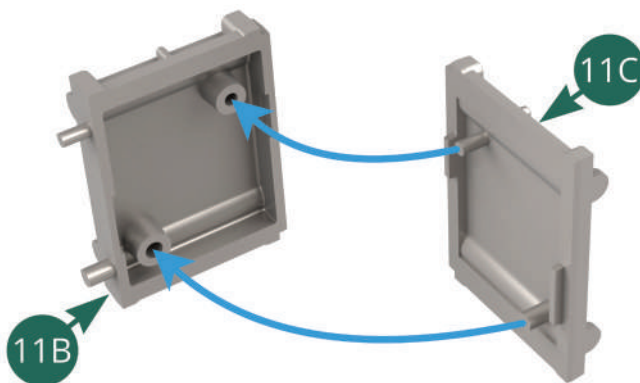

You may need to file excess paint off the camshaft gear box so that it fits flush with the engine block.

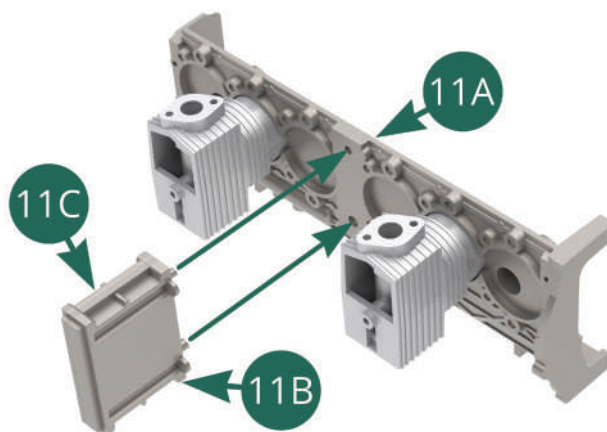

STAGE 11: LEFT-SIDE OF ENGINE BLOCK

STEP 3

Align the left engine block assembly with the **right engine block (7A)** as shown. Firmly push into position then attach with two **JM** screws.

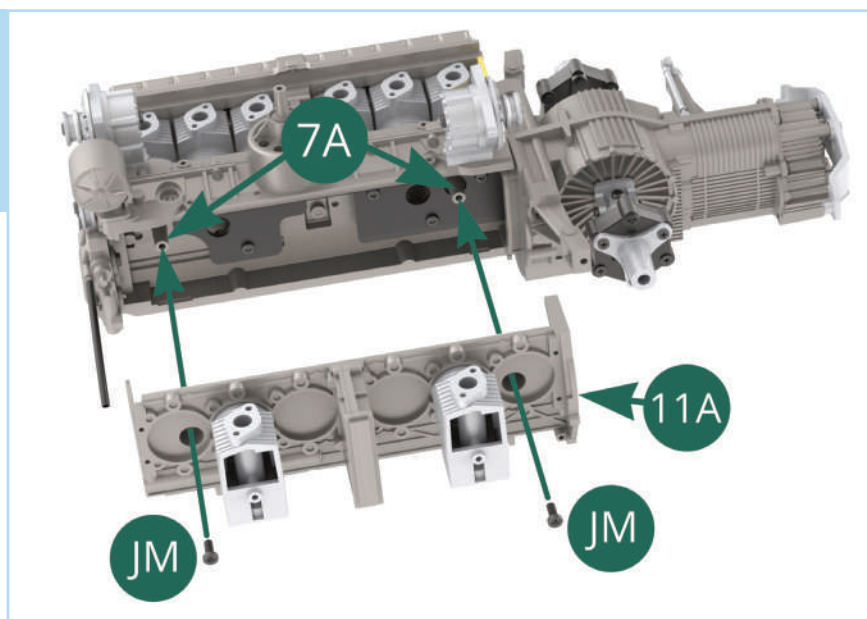

STAGE COMPLETE

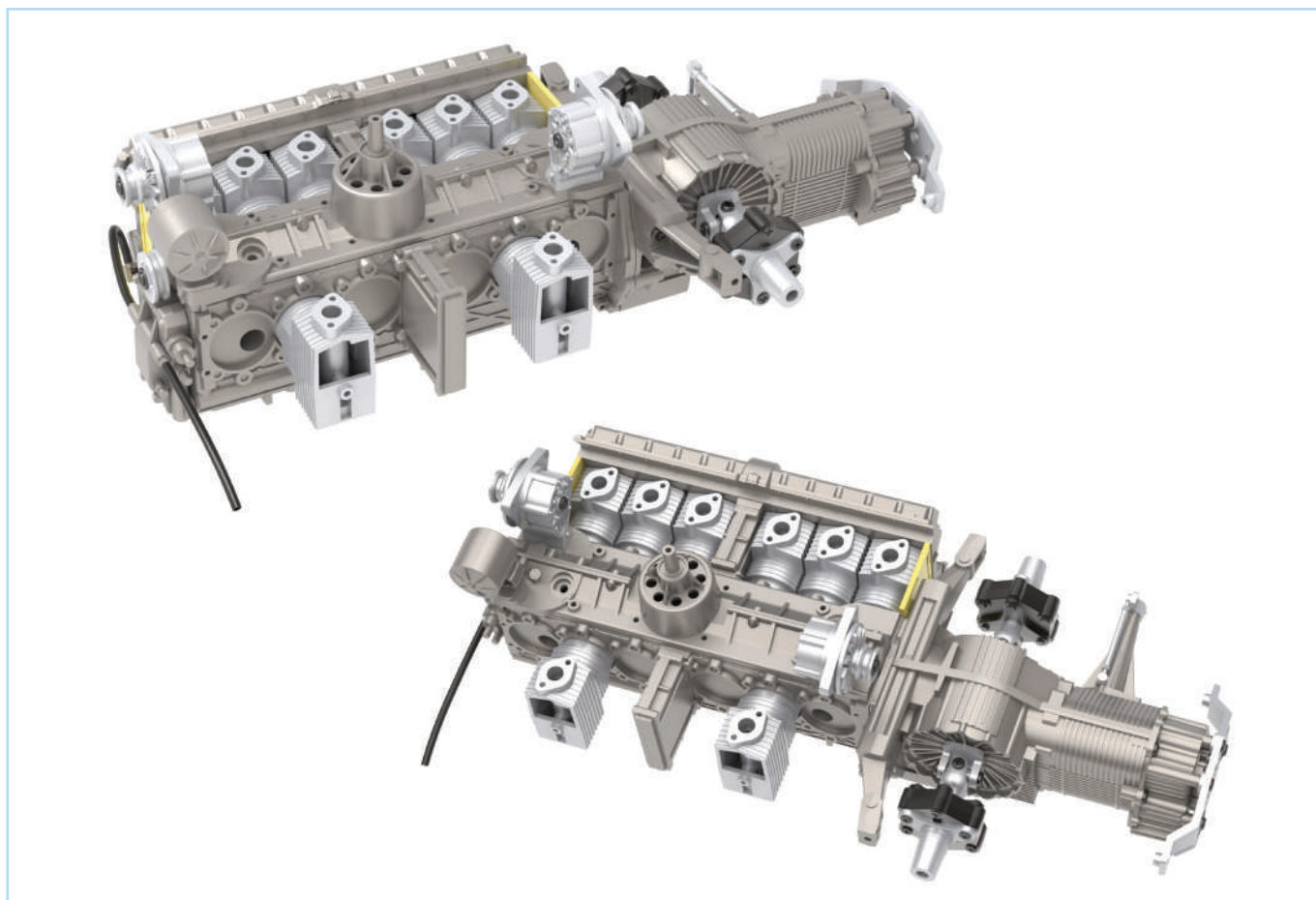

STAGE 12: BUILDING THE FUEL PUMP

12A Intake cam cover

12B Main gear

12C Fuel pump

12D Side cover (x2)

12E Fuel pump housing

12F Secondary gear

12G Fuel pump base

12H Panel

12I Fuel pump outer body

12J Connector

12K Toothed belt

12L Injector nozzle (x15)

12M Housing cover

AP Screw 1.7 x 4mm (x6)

DP Screw 1.7 x 3 x 5mm (x3)

JP Screw 1.7 x 4mm (x3, silvered)

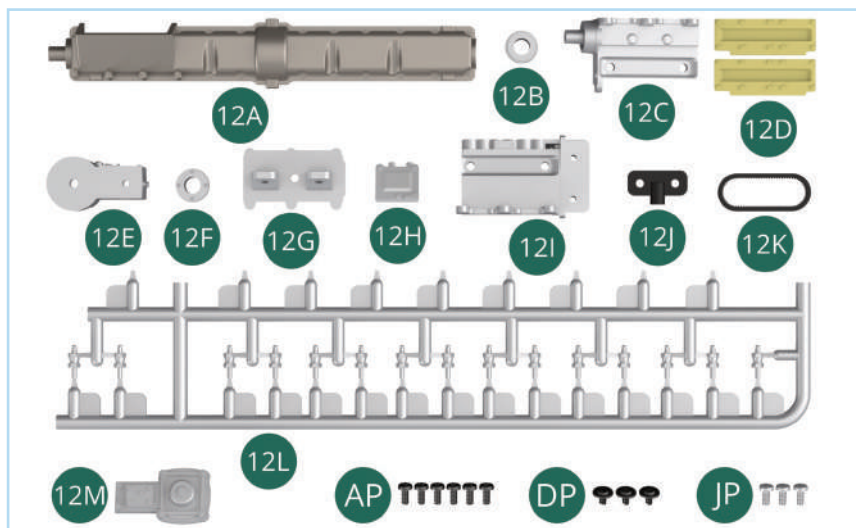

To distinguish the **main gear (12B)** from the **secondary gear (12F)**, note the four rivets on the secondary gear, and that it is larger than the main gear.

ASSEMBLY DIAGRAM

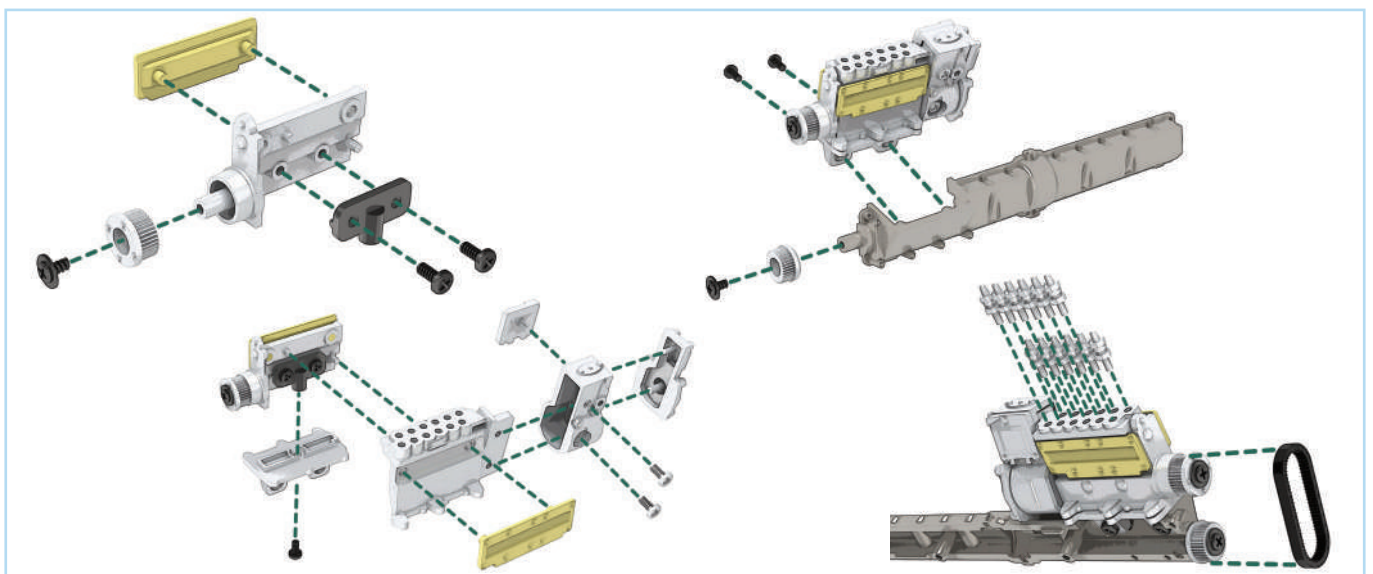

STAGE 12: BUILDING THE FUEL PUMP

STEP 1

Fit the **secondary gear (12F)** onto the shaft of the **fuel pump (12C)** in the orientation shown and secure in place with a **DP** screw.

Align the **connector (12J)** with the **fuel pump (12C)**, placing the two semi-circular notches (orange arrow) over the screw holes on the fuel pump and secure it using two **AP** screws.

Take one of the **side covers (12D)** and fit it onto the side of the fuel pump by pressing firmly into place.

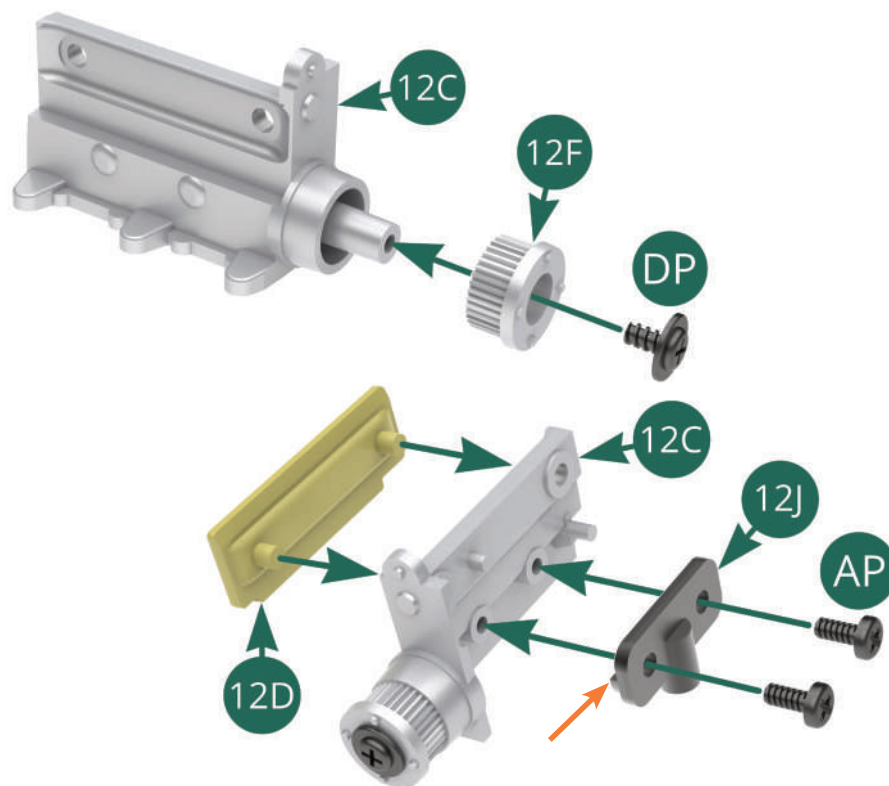

STEP 2

Fit the fuel pump into the **fuel pump outer body (12I)**, then press the remaining **side cover (12D)** into the outer body.

You may need to remove excess paint from the outer body to ensure a flush fit.

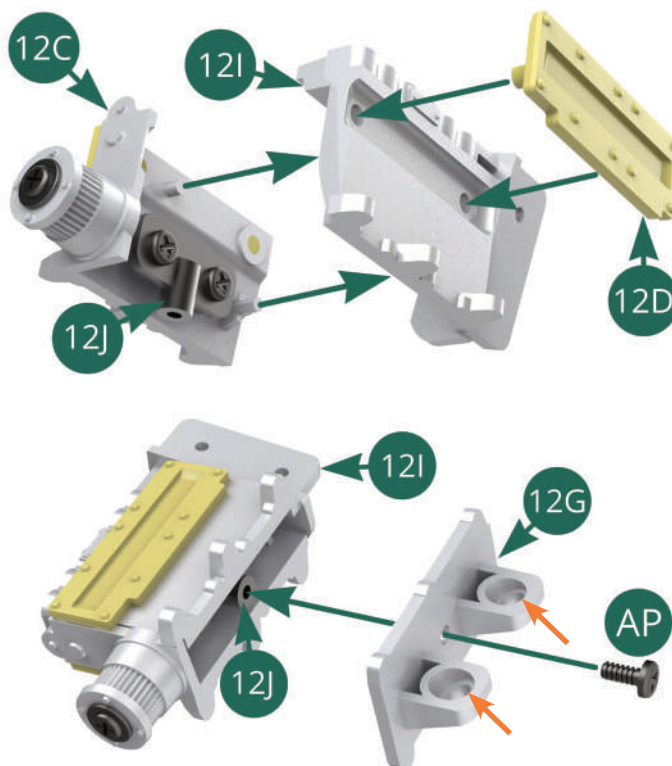

Align the **fuel pump base (12G)** as shown and push into position. Secure the base with an **AP** screw.

Note the wide holes (orange arrows) when aligning the fuel pump base.

STAGE 12: BUILDING THE FUEL PUMP

STEP 3

Fit the assembly into the **fuel pump housing (12E)** and secure the parts together using two of the silvered **JP** screws.

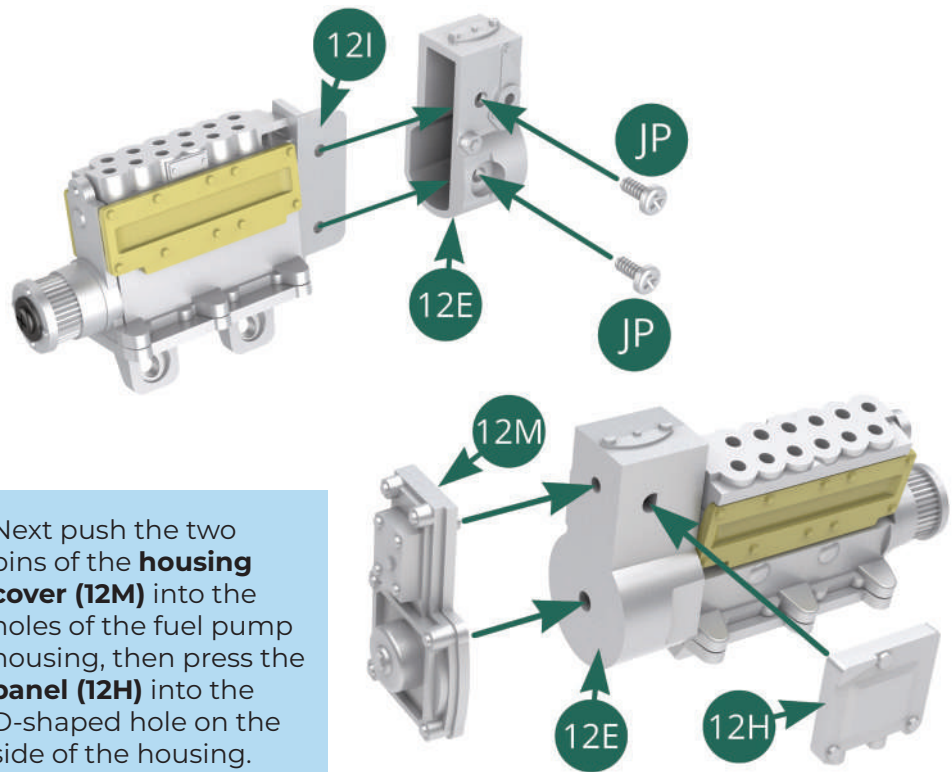

STEP 4

Fit the **main gear (12B)** onto the shaft of the **intake cam cover (12A)** and attach it with a **DP** screw. Take the fuel pump assembly and fit the holes of the **fuel pump base (12G)** over the corresponding screw holes of the cam cover. Holding it in place, secure the fuel pump to the cover using two **AP** screws.

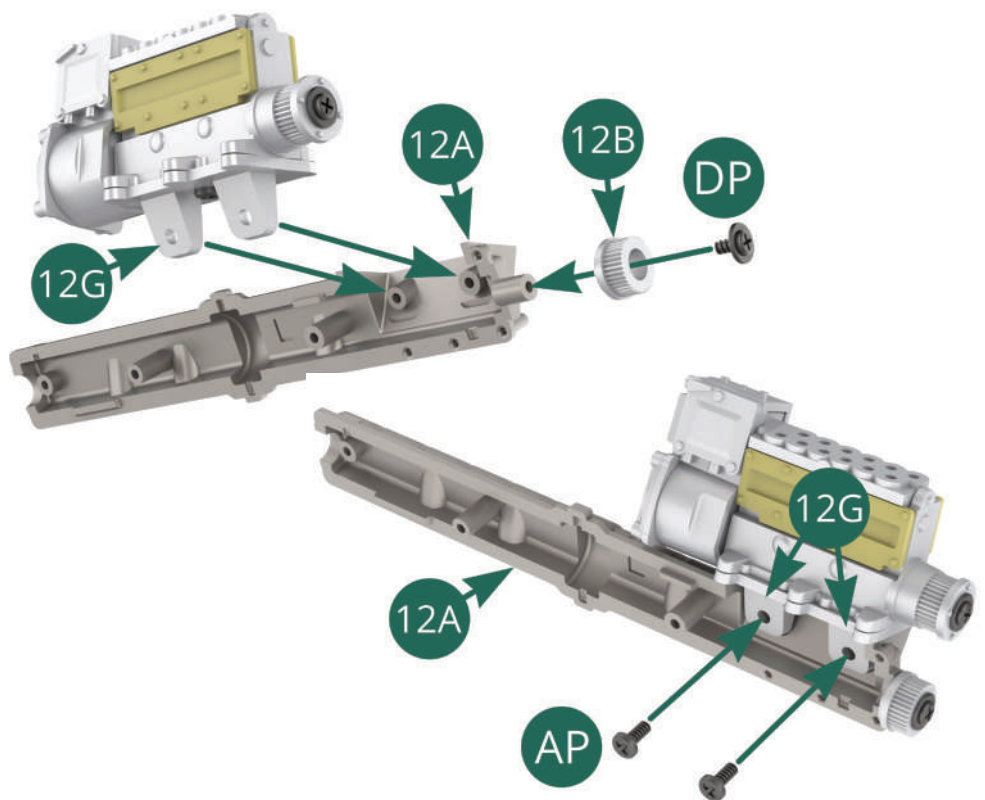

STAGE 12: BUILDING THE FUEL PUMP

STEP 5

Take the **toothed belt (12K)** and place it around the main and secondary gear (**12B** and **12F**) of the fuel pump as shown.

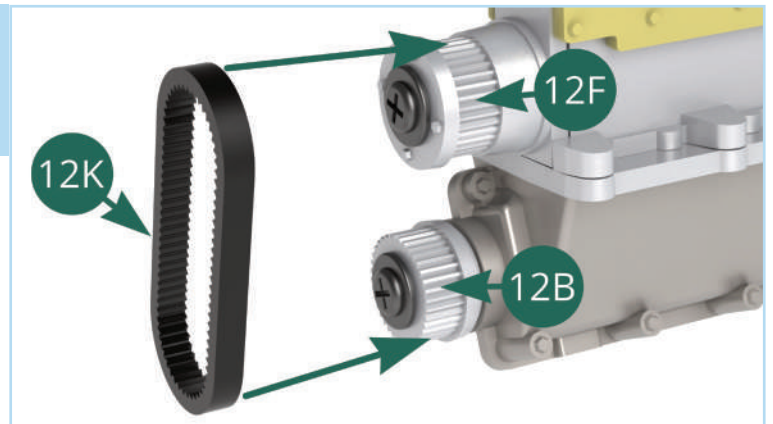

STEP 6

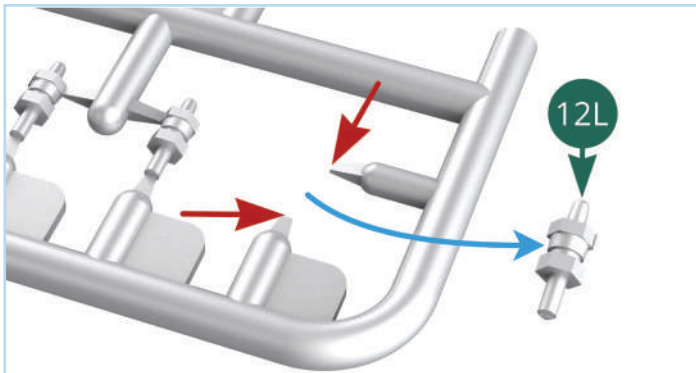

Using sprue cutters, carefully detach twelve **injector nozzles (12L)** from their sprue at the points indicated by the red arrows.

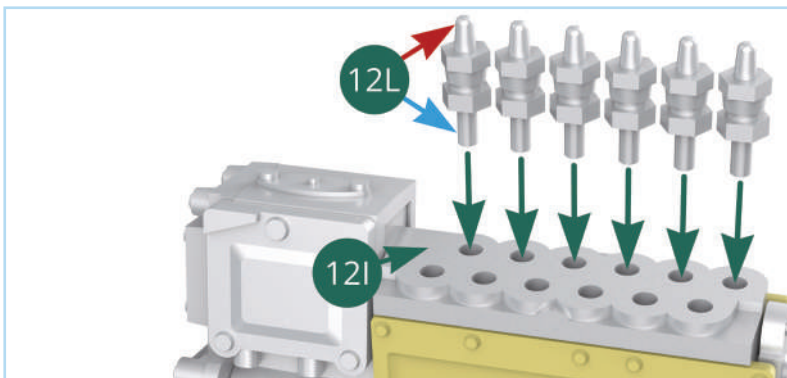

Push six of the injector nozzles into the **fuel pump outer body (12I)**. Note the rounded end (red arrow) points up and the flat end (blue arrow) fits into the hole when fitting an injector in place.

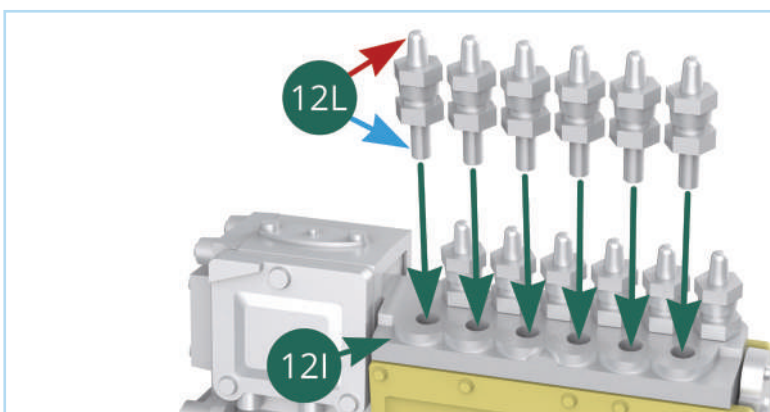

Push the other six injector nozzles into the remaining holes on the fuel pump.

STAGE 12: BUILDING THE FUEL PUMP

STAGE COMPLETE

