

STEVE MCQUEEN'S ICONIC **PORSCHE** **917KH**



Pack 05

BUILD INSTRUCTIONS

**STAGE 29: INSTALLING THE
FRONT RIGHT SUSPENSION**

**STAGE 30: FITTING THE BRAKES,
STEERING AND FRONT SUSPENSION**

**STAGE 31: ADDING THE LEFT COCKPIT
TUBULAR FRAME TO THE CHASSIS**

**STAGE 32: ATTACHING THE LEFT FUEL TANK
WITH THE CIRCUIT BOARD**

**STAGE 33: ATTACHING THE RIGHT FUEL TANK
AND CABLES**

**STAGE 34: ADDING THE RIGHT COCKPIT
TUBULAR FRAME TO THE CHASSIS**

**STAGE 35: FIXING THE MUDGUARDS AND
ADDING THE ELECTRICAL CABLES**

**STAGE 36: ASSEMBLING AND ATTACHING
THE RIGHT FRONT WHEEL**

**STAGE 37: FITTING THE COCKPIT PARTITION
FRAME AND THE OIL HOSES**

Porsche, the Porsche shield and the distinctive design of Porsche cars are trademarks and trade dress of Porsche AG. Permission granted.

The Gulf trademarks are used under license from Gulf Oil International Ltd.

Personality rights of Steve McQueen are used with permission of Chadwick McQueen and The Terry McQueen Testamentary Trust.

Represented exclusively by Greenlight.

AGORA
MODELS

Advice from the experts

Spare screws are included with each part. Occasionally, you may be instructed to keep spare or unused screws for a later stage. Keep these spares in a safe place and label them correctly.

Please make sure you don't mix up the screws. They look quite similar, but the threads do vary slightly. Using the wrong screws may damage the parts.

When securing parts together using multiple screws, fit each screw loosely to ensure all the parts are correctly aligned before gently tightening them firmly, but not overtight, in the order in which you placed them.

The screwdriver can be magnetized by stroking it with a magnet (fridge magnet, etc.) enabling it to hold the screws and make assembly easier.

If a screw is tight going into a metal part, do not force it as you may shear the head off. Remove it and put a tiny smear of Vaseline, soap or light oil on the thread. That will lubricate it and make it easier to drive home.

During the course of this build, you will receive many pieces that you will assemble immediately – following the instructions in the corresponding stage – and other pieces that you should store safely to one side, for use in future assembly stages.

Left and Right! When building your Porsche 917KH, the left or right hand side refers to each side as you are sitting in the car.



WARNING: Some parts are assembled using magnets. These magnets can cause serious injury if they are swallowed. Keep away from children. If you suspect a magnet has been swallowed, seek medical help straight away.

STAGE 29: INSTALLING THE FRONT RIGHT SUSPENSION

- 29A** Upper control arm
- 29B** Bracket (x2)
- 29C** Shock absorber upper bracket '1'
- 29D** Shock absorber piston
- 29E** Shock absorber spring
- 29F** Shock absorber cylinder
- 29G** Shock absorber lower bracket '2'
- 29H** Hub carrier top
- 29I** Hub carrier bottom
- 29J** Lower control arm
- 29K** Lower control arm bracket '3' (x2)
- 29L** Hub carrier joint (x2)
- BM** Screw 2.0 x 4 mm (x8)
- CM** Screw 2.0 x 3 x 5 mm (x3)
- DM** Screw 2.0 x 8 mm (x4)
- EM** Screw 2.0 x 9 mm (x4)

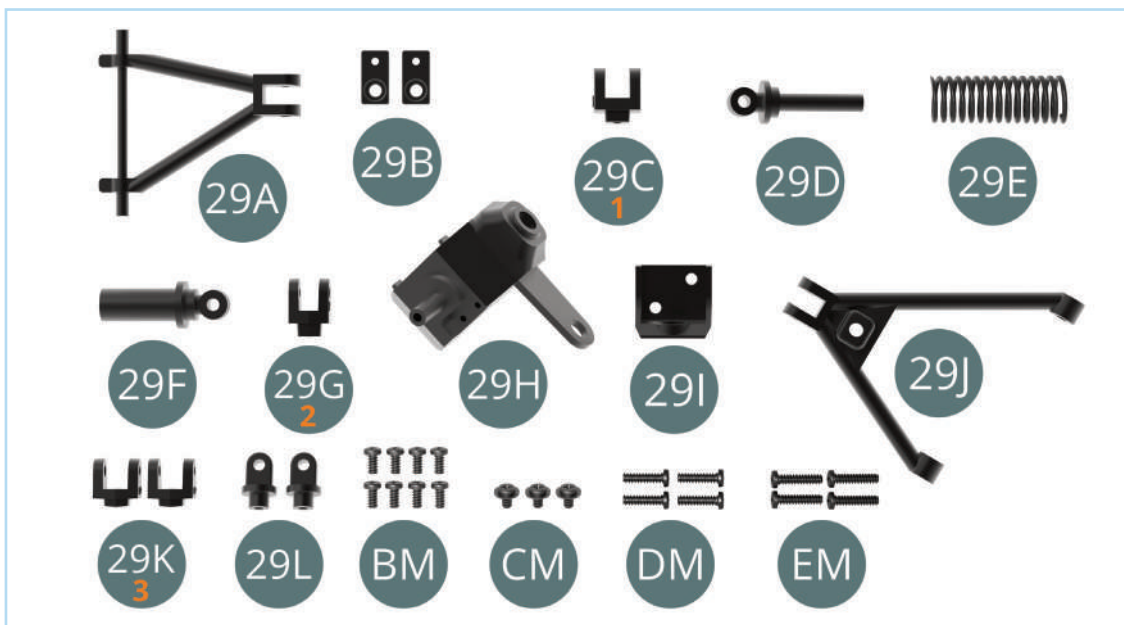

ASSEMBLY DIAGRAM

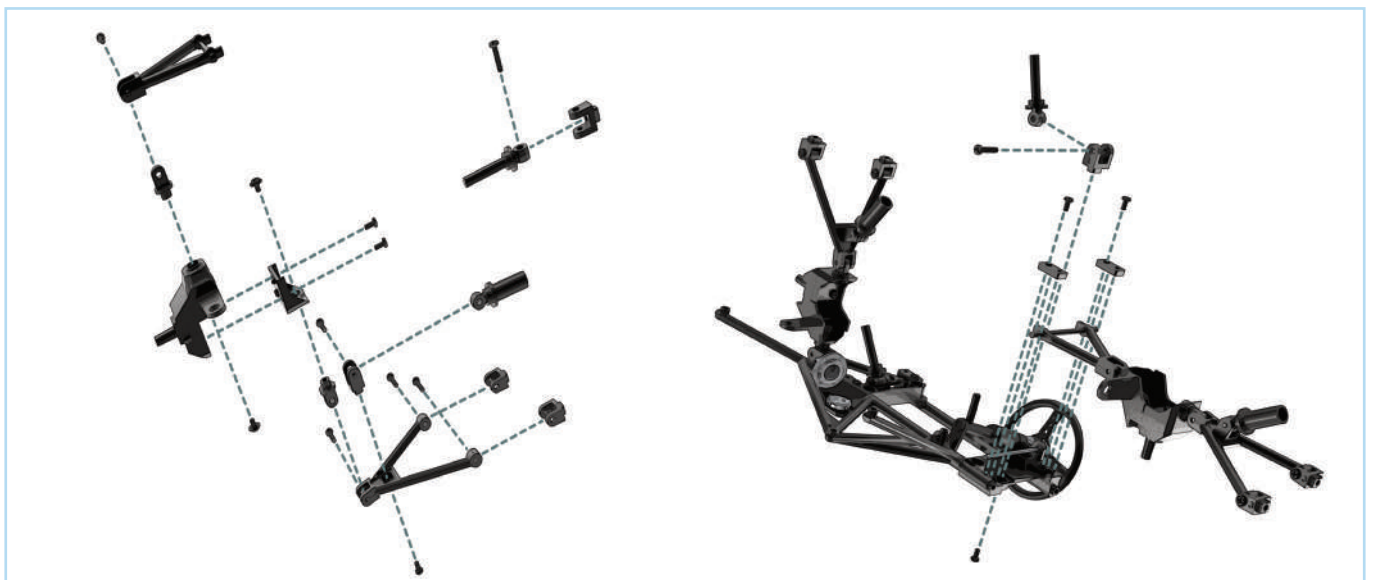

STAGE 29: INSTALLING THE FRONT RIGHT SUSPENSION

STEP 1

Take the **hub carrier joint (29L)** and fit it into the **upper control arm (29A)**, then secure by driving a **DM** screw through the larger hole (red arrow).

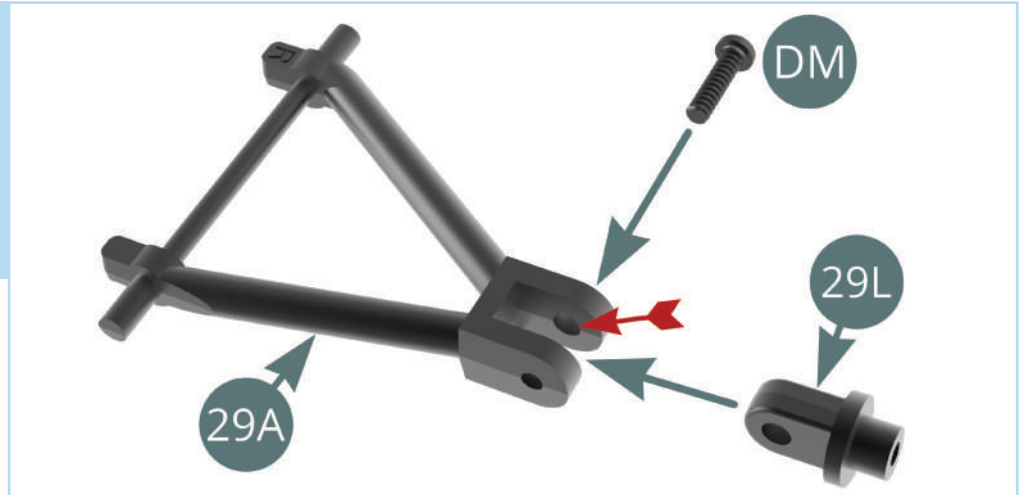

Fit the lug of the **hub carrier joint (29L)** into the hole at the top of the **hub carrier top (29H)**. Fix the parts together using a **CM** screw as shown.

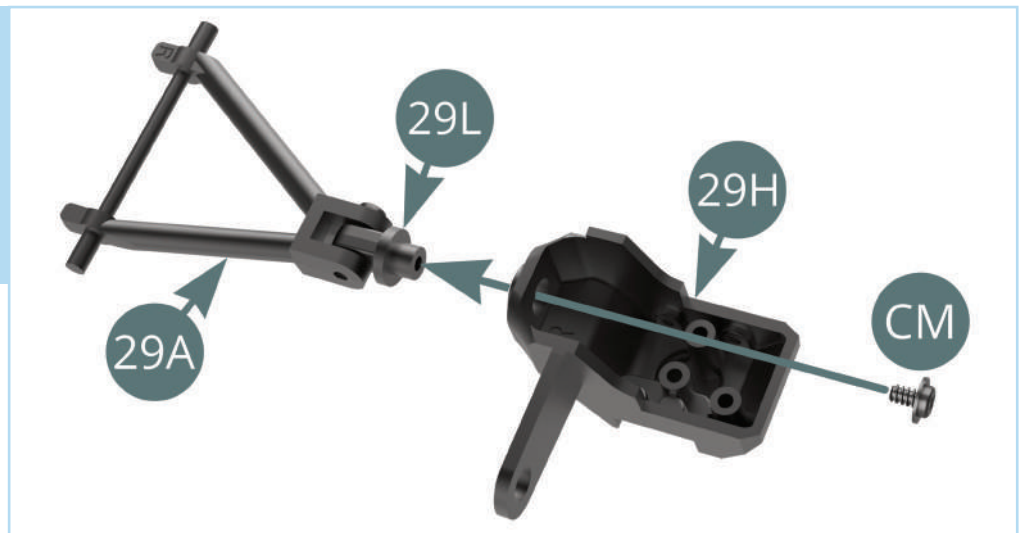

STEP 2

Next fit the two **lower control arm brackets (29K)**, marked with a '3', onto the ends of the **lower control arm (29J)** as shown. Secure each in place by driving an **EM** screw through the larger hole of each bracket (red arrows).

If the screws are hard to drive through, use a drop of oil to lubricate them.

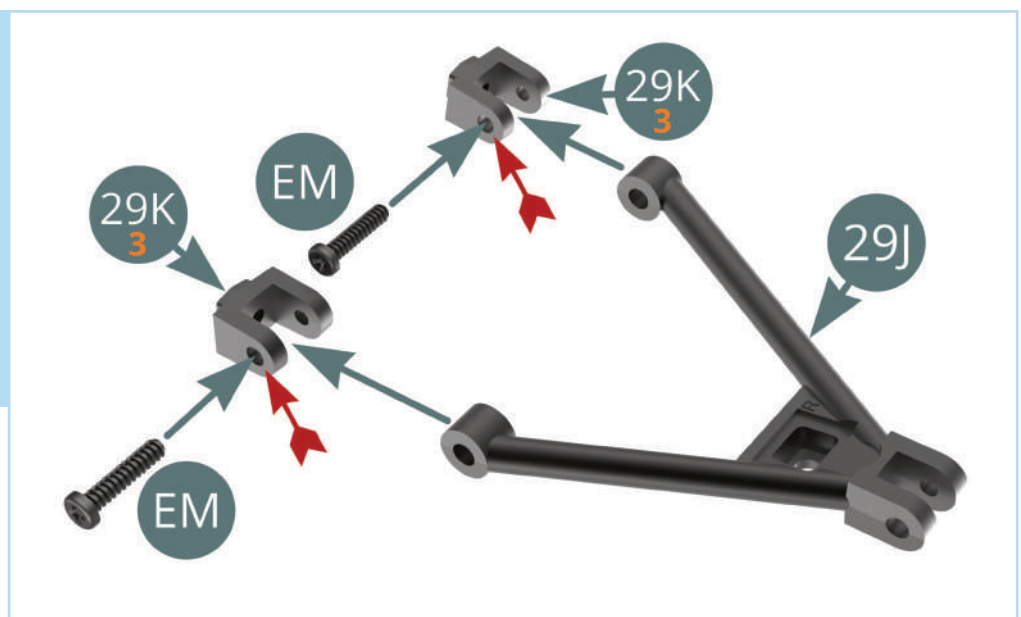

STAGE 29: INSTALLING THE FRONT RIGHT SUSPENSION

Now take the other **hub carrier joint (29L)** and fit it into the end of the **lower control arm (29J)** as shown. Fix the parts together using a **DM** screw, driving it through the larger hole (red arrow) of the control arm.

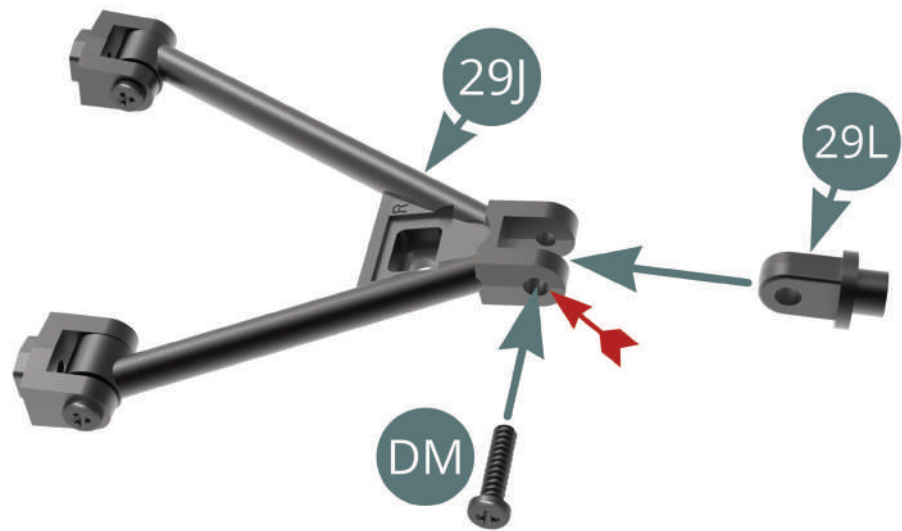

Take the **shock absorber cylinder (29F)** and the **shock absorber lower bracket (29G)**, marked with a '2'. Push the parts together as shown, then drive a **DM** screw through the larger hole of the bracket (red arrow).

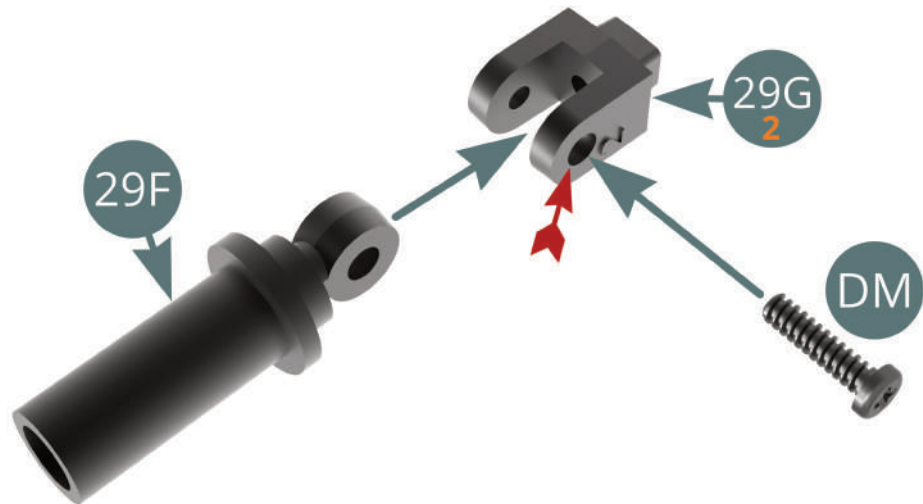

Fit the square lug of the **shock absorber lower bracket (29G)** into the corresponding hole in the **lower control arm (29J)**. Secure using a **BM** screw as shown.

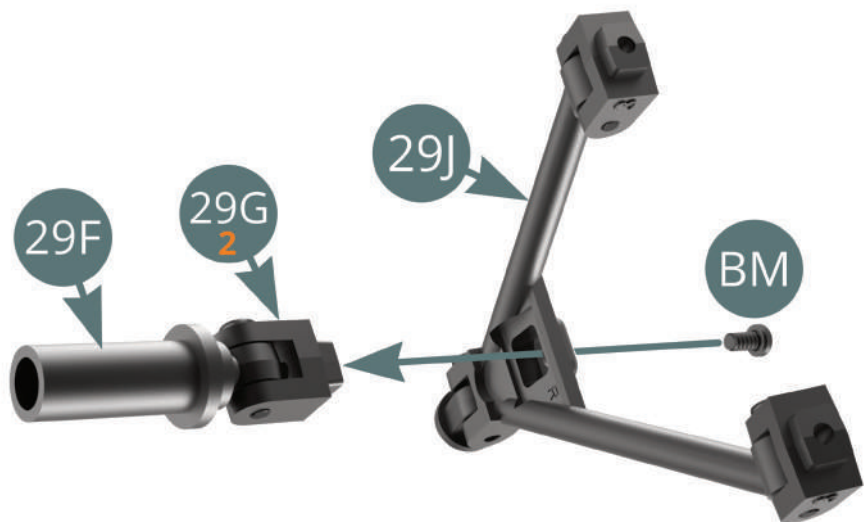

STAGE 29: INSTALLING THE FRONT RIGHT SUSPENSION

STEP 3

Fit the **hub carrier bottom (29I)** onto the top of the **lower control arm (29J)**, then secure together using a **CM** screw.

Note the control arm should be able to rotate freely.

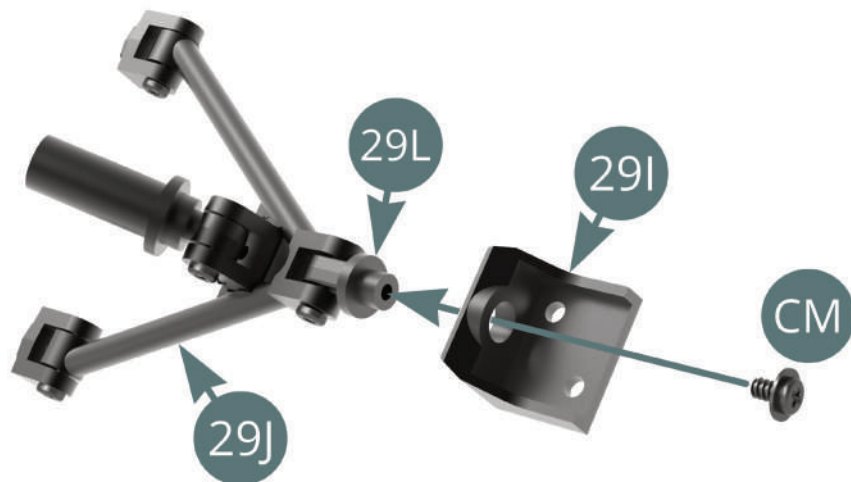

Now place the **hub carrier bottom (29I)** onto the **hub carrier top (29H)**, then secure together using two **BM** screws.

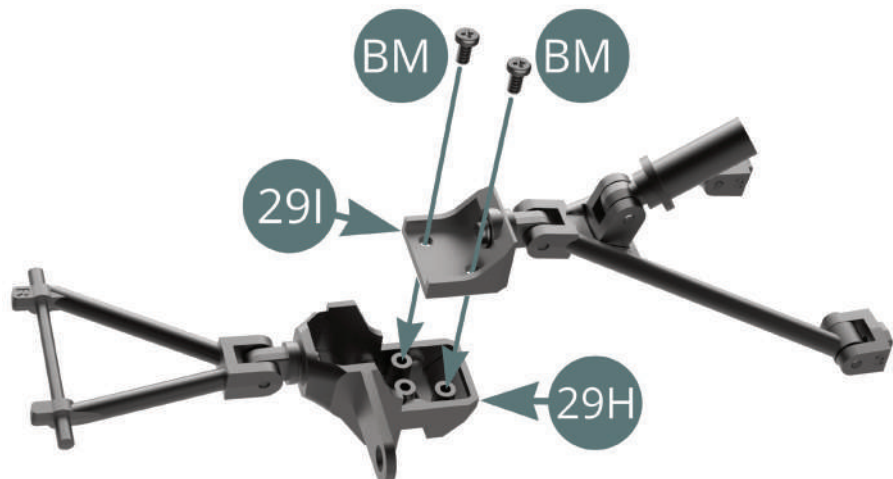

The front right suspension assembly should now look like this.

STAGE 29: INSTALLING THE FRONT RIGHT SUSPENSION

STEP 4

Position the **shock absorber upper bracket (29C)**, marked with a '1', onto the top of the **shock absorber piston (29D)**. Drive an **EM** screw through the larger hole of the bracket (red arrow).

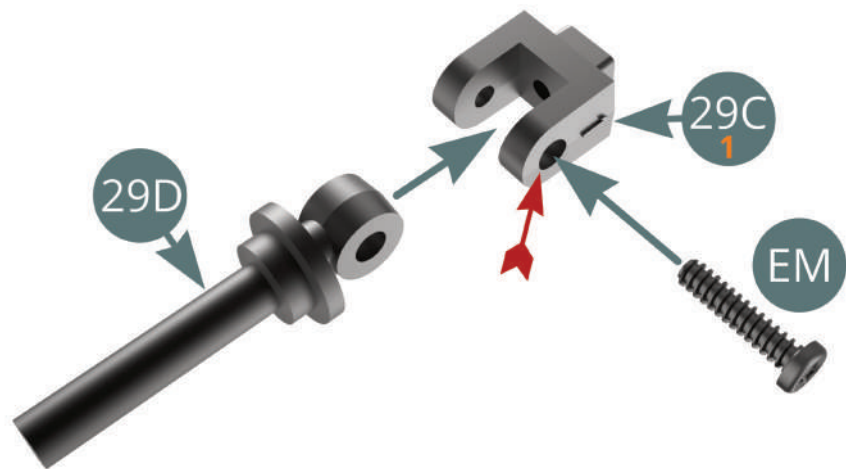

Take the dashboard frame assembly from Stage 28 and fit the **shock absorber upper bracket (29C)** in place on the side of the frame. Secure in place using a **BM** screw.

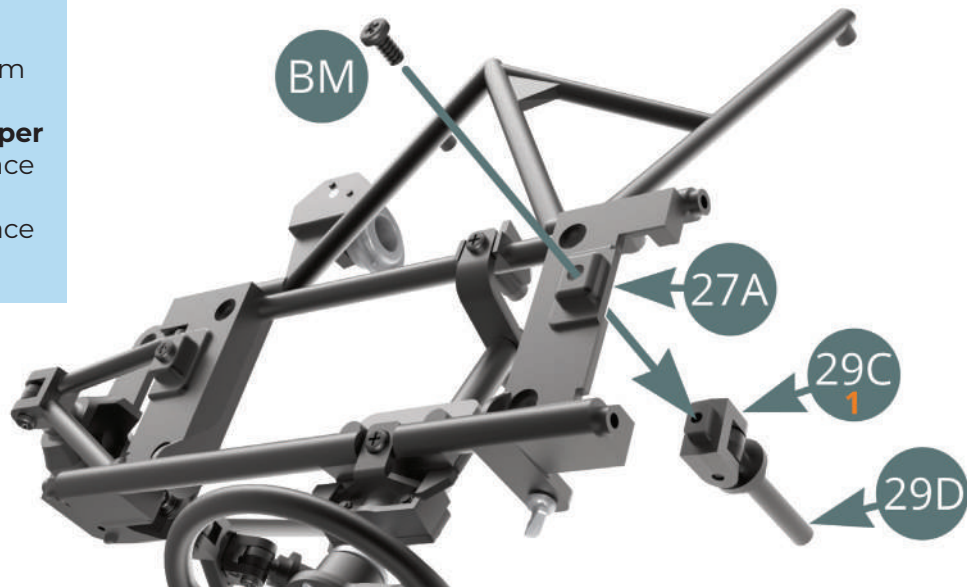

Position the **upper control arm (29A)** on the **dashboard frame (27A)** in the orientation shown, then fit the **brackets (29B)** in place over the ends of the upper control arm.

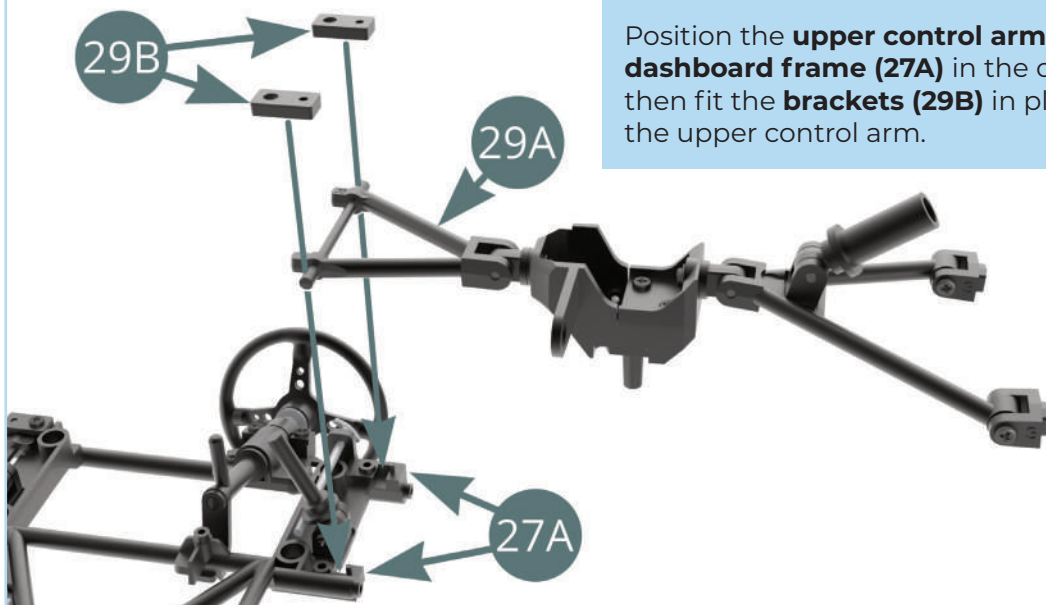

STAGE 29: INSTALLING THE FRONT RIGHT SUSPENSION

Secure the brackets firmly in place using two **BM** screws. The suspension should be able to move, so be sure not to overtighten the screws.

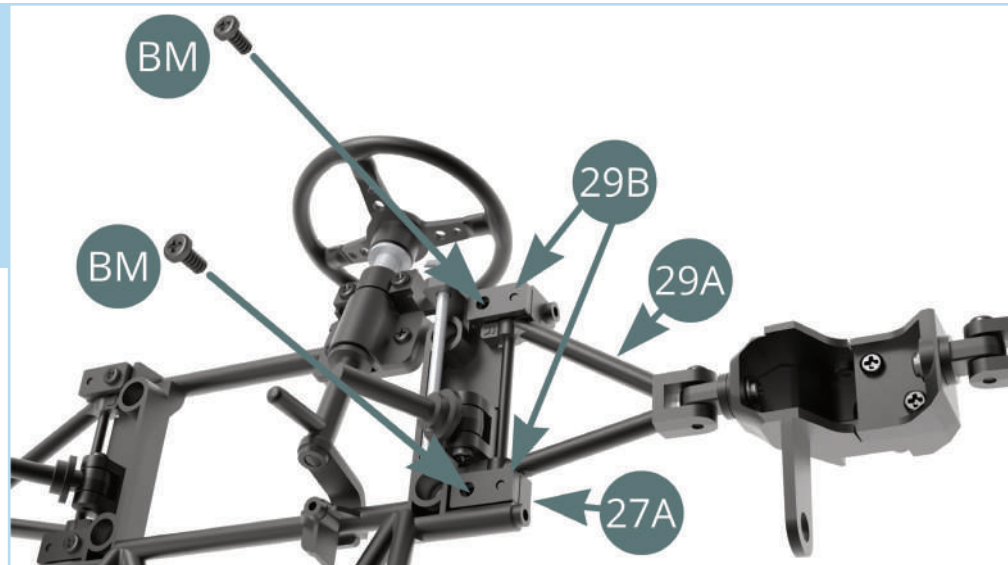

STAGE COMPLETE



STAGE 30: FITTING THE BRAKES, STEERING AND FRONT SUSPENSION

30A Left brake caliper

30B Brake piston cover (x2)

30C Left brake disc cooling air duct

30D Right brake disc inner surface (red arrows indicate direction of ventilation holes)

30E Right brake disc outer surface (red arrows indicate direction of ventilation holes)

30F Brake disc rotor (inner half)

30G Brake disc rotor (outer half)

30H Right brake caliper

30I Right brake disc cooling air duct

30J Steering rod

30K Steering bar

BM Screw 2.0 x 4 mm (x8)

CM Screw 2.0 x 3 x 5 mm (x3)

IM Screw 1.7 x 3.5 mm (x10)

KM Screw 1.7 x 3 x 5 mm (x2)

CP Screw 1.7 x 3 x 5 mm (x3)



STAGE 30: FITTING THE BRAKES, STEERING AND FRONT SUSPENSION

ASSEMBLY DIAGRAM

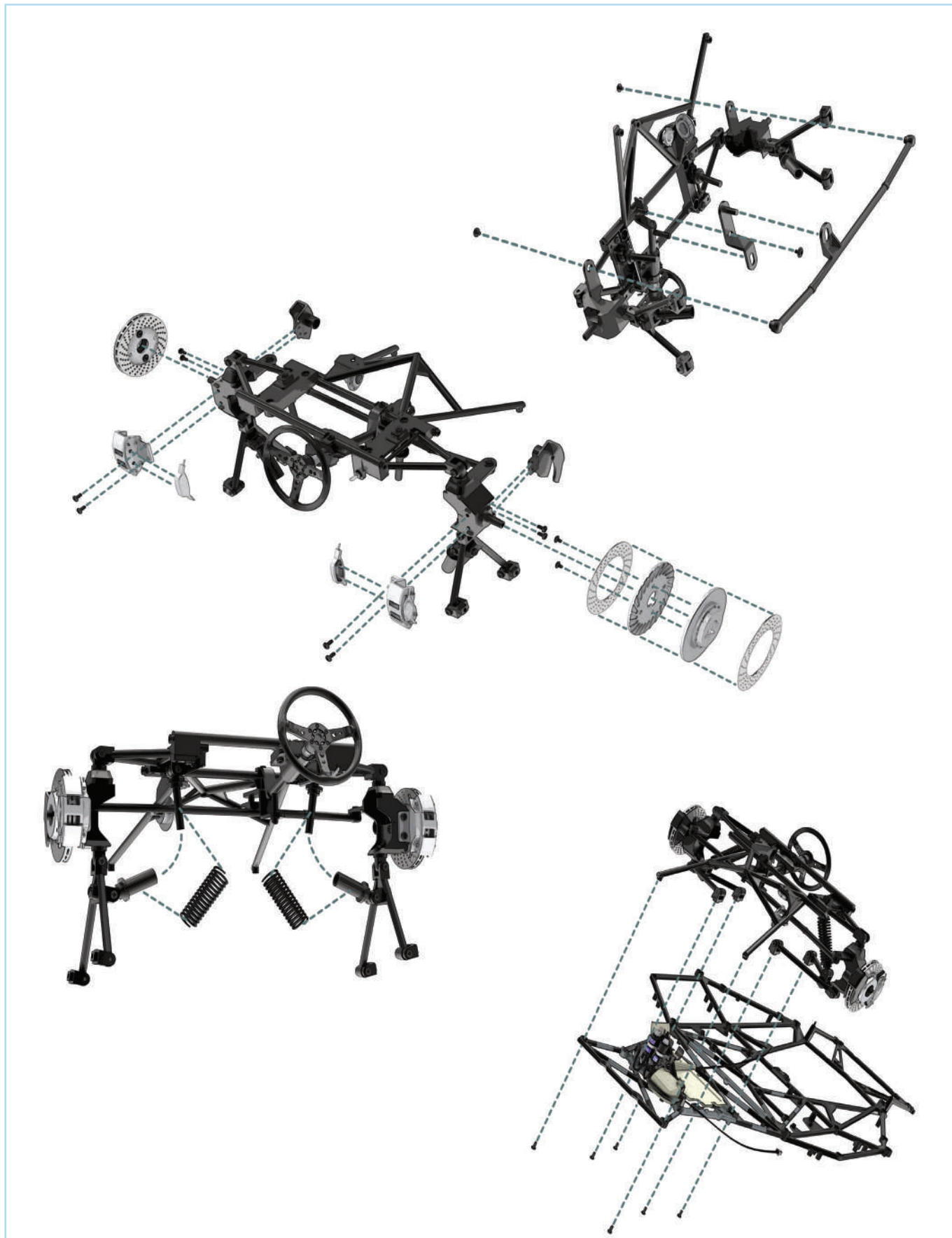

STAGE 30: FITTING THE BRAKES, STEERING AND FRONT SUSPENSION

STEP 1

Take the dashboard frame assembly and position the **steering link (30J)** in place. Ensure that the pin at the end of the steering wheel column (**2B**) fits in the slot as shown by the red arrow. Secure the link using a **KM** screw, making sure it is able to move freely when turning the steering wheel.

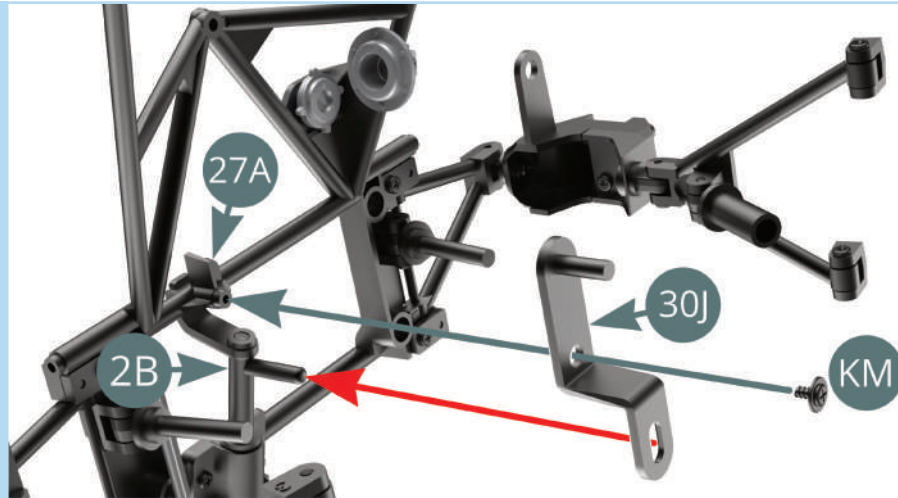

Align the **steering bar (30K)** with the dashboard frame as shown. Press the lugs at the end of the bar into the holes of the **hub carriers (3G and 29H)**. At the same time, fit the slot onto the pin of the **steering link (30J)** as shown by the red arrow. Fix the bar to the hub carriers by driving a **CM** screw in at each end.

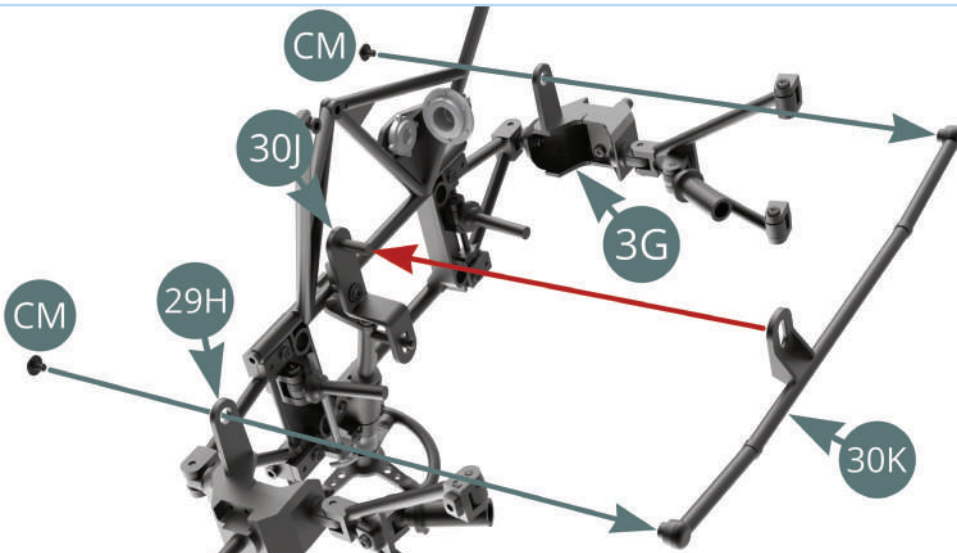

The dashboard frame should look like this once the steering link and bar have been attached to it.



STAGE 30: FITTING THE BRAKES, STEERING AND FRONT SUSPENSION

STEP 2

Position the **left brake disc cooling air duct (30C)** onto the **left hub carrier (3G)** in the orientation shown then secure it in place using two **IM** screws.

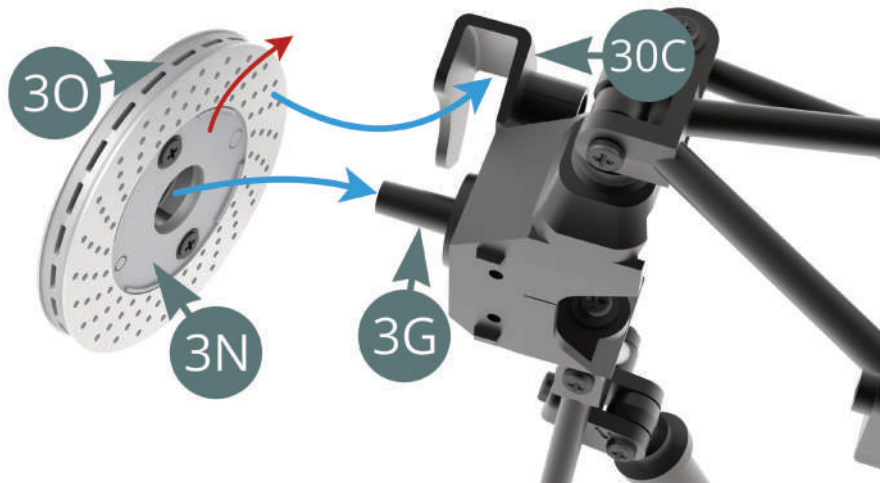

Retrieve the **left brake disc (30 and 3N)** from Stage 3 and fit it onto the **hub carrier (3G)** and **left brake disc cooling air duct (30C)** as shown by the blue arrows.

Note the orientation of the ventilation holes (red arrow).

This image shows left brake disc fitted in place.

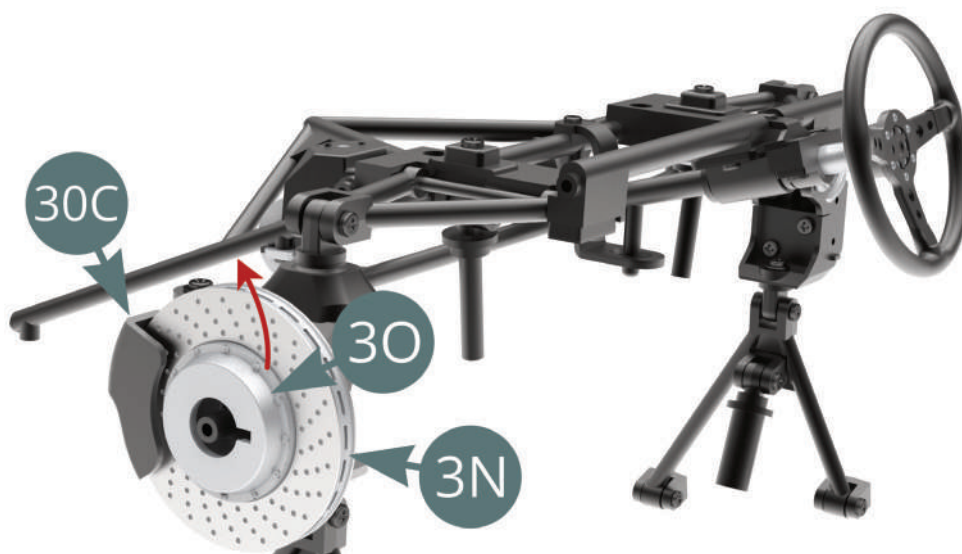

STAGE 30: FITTING THE BRAKES, STEERING AND FRONT SUSPENSION

STEP 3

Fit the **left brake caliper (30A)**, marked with an 'L', onto the **hub carrier (3G)** and fix it in place using two **IM** screws.

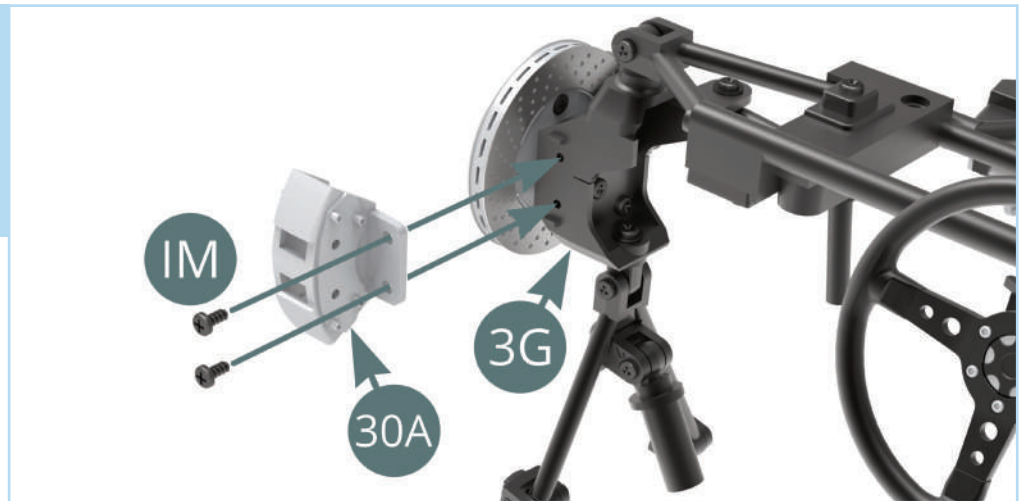

Attach one of the **brake piston covers (30B)** to the **left brake caliper (30A)** by pressing the two small pins on the cover into the corresponding holes on the caliper. Make sure that the cover is oriented the correct way as shown in the image, following the curve of the brake caliper.

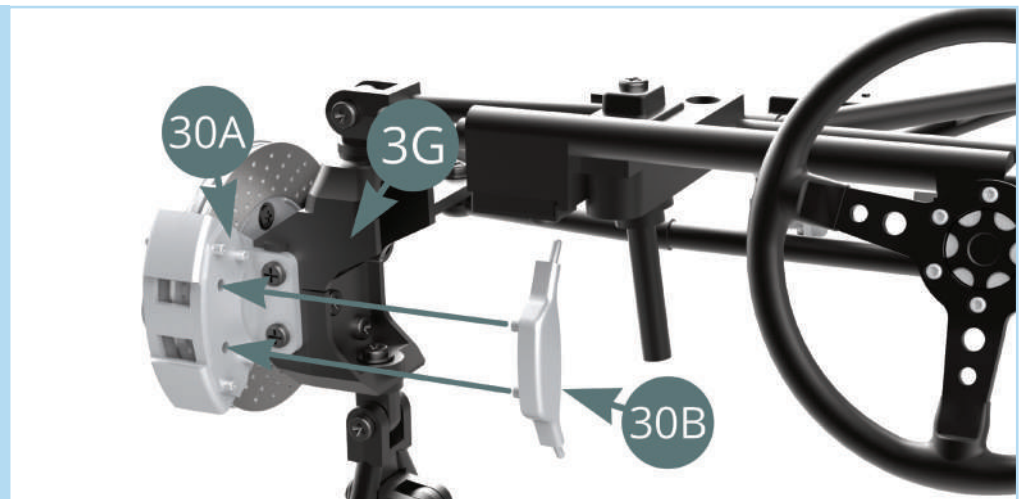

STEP 4

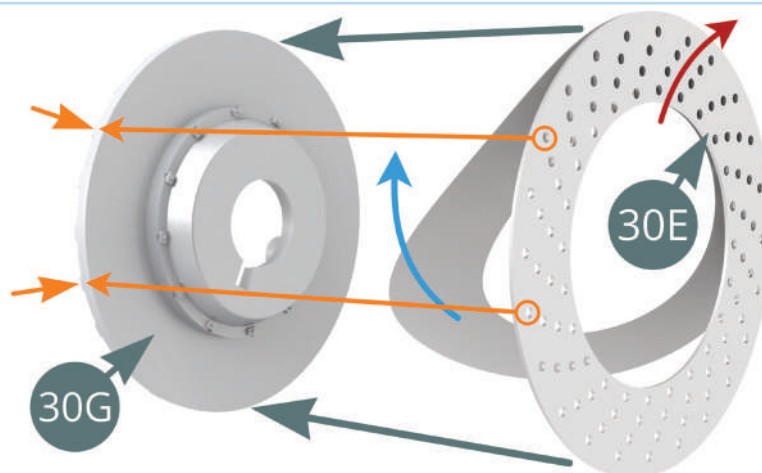

Next take the **right brake disc outer surface (30E)** and remove the backing paper (blue arrow). Stick it to the **brake disc rotor (outer half) (30G)** using the adhesive side. Take note of the direction of the ventilation holes (red arrow). Ensure the outer holes align with the ribs of the disc (orange arrows).

STAGE 30: FITTING THE BRAKES, STEERING AND FRONT SUSPENSION

In the same manner, peel the backing paper from the **right brake disc inner surface (30D)** and stick it to the **brake disc rotor (inner half) (30F)**.

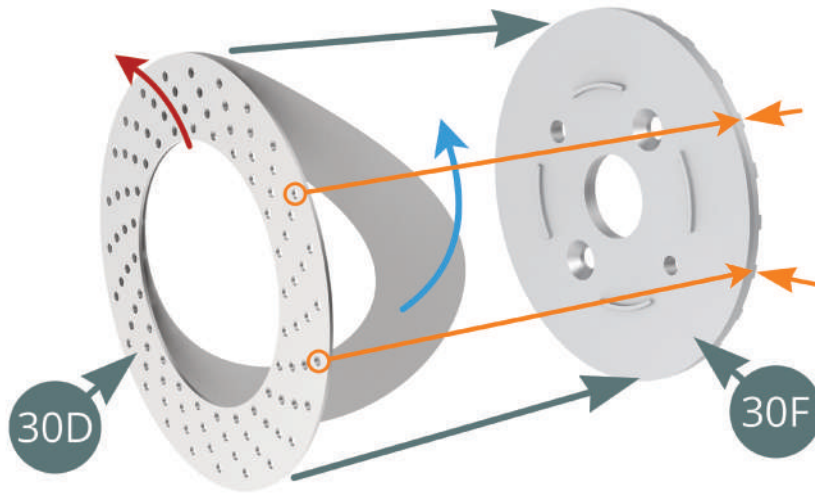

Fit the two halves of the brake disc (**30F and 30G**) together as shown and fix them using two **CP** screws.

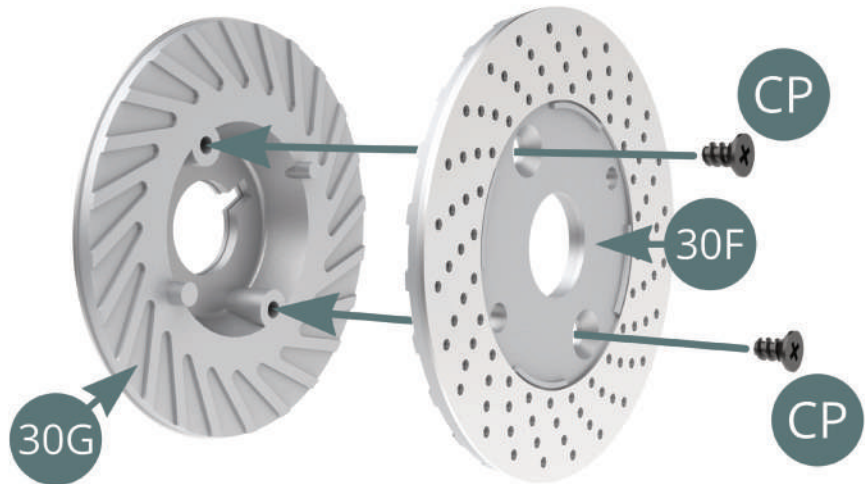

The right brake disc has been assembled.

STAGE 30: FITTING THE BRAKES, STEERING AND FRONT SUSPENSION

STEP 5

Now fit the **left brake disc cooling air duct (30I)** onto the **hub carrier (29H)** and secure in place using two **IM** screws.

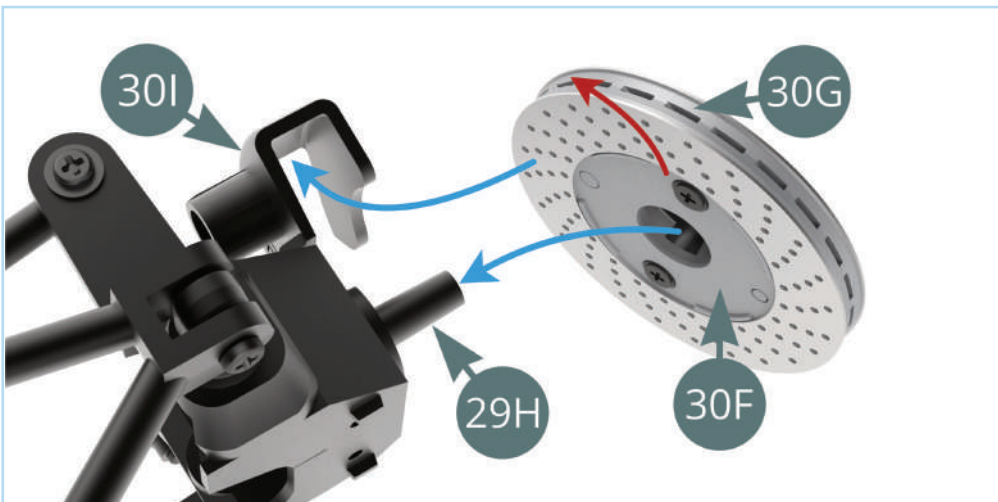

Fit the right brake disc (**30F and 30G**) onto the **hub carrier (29H)** and **left brake disc cooling air duct (30I)** as shown by the blue arrows.

Note the orientation of the ventilation holes (red arrow).

This image shows the right brake disc fitted in place.

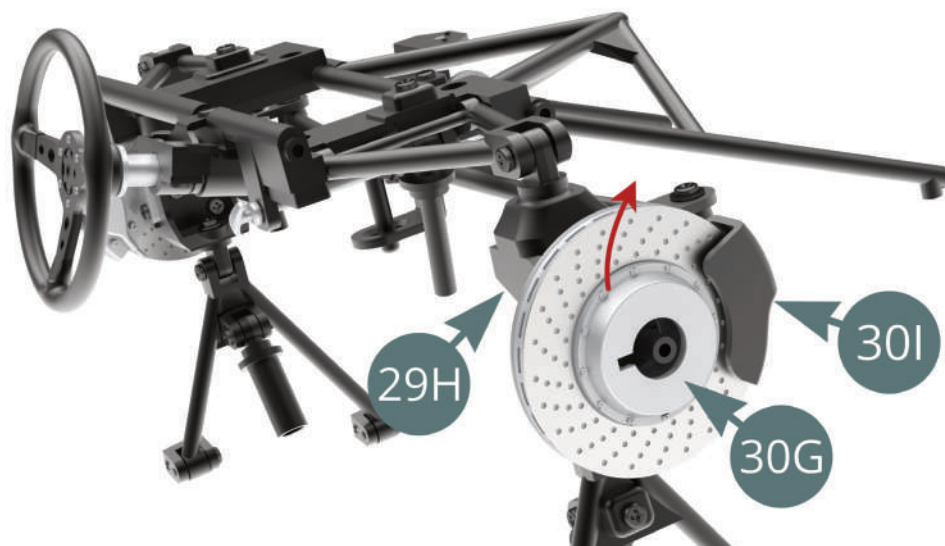

STAGE 30: FITTING THE BRAKES, STEERING AND FRONT SUSPENSION

STEP 6

Fit the **right brake caliper (30H)** onto the **hub carrier (29H)** and fix it in place using two **IM** screws.

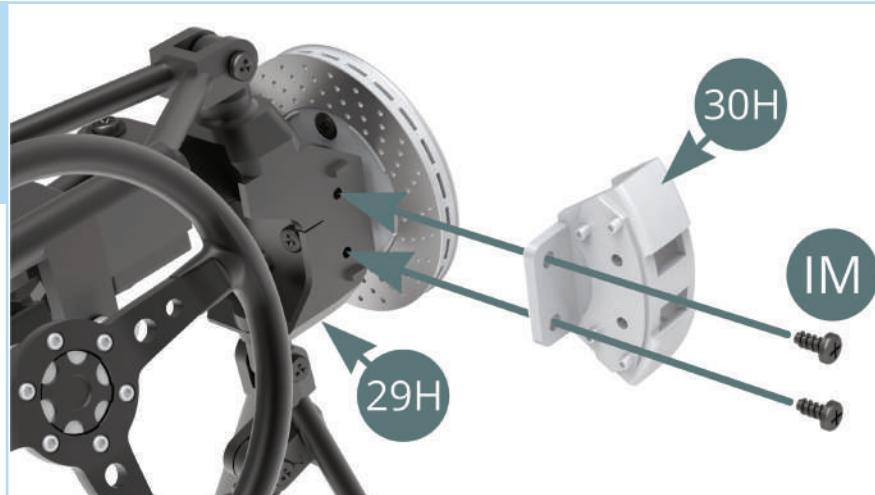

Push the remaining **brake piston cover (30B)** into the **right brake caliper (30H)** in the same manner as the previous one.

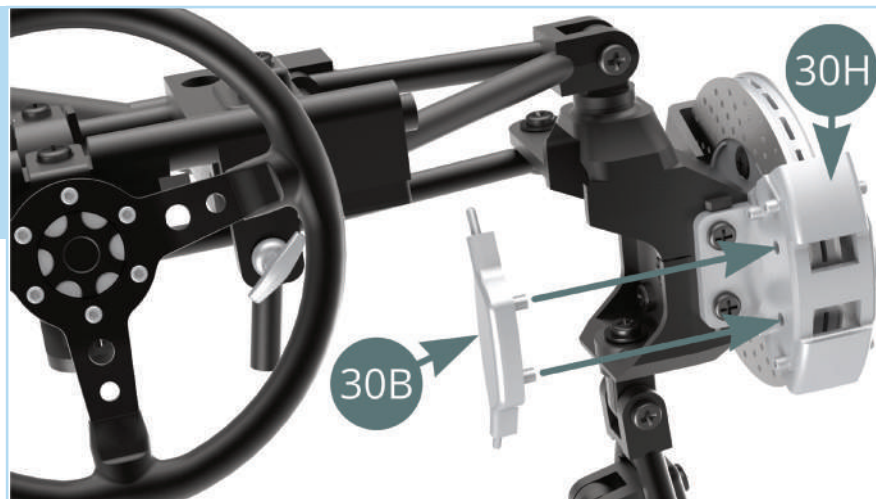

The brakes, steering and front suspension have been fitted to the dashboard frame .



STAGE 30: FITTING THE BRAKES, STEERING AND FRONT SUSPENSION

STEP 7

Take the chassis assembly. To attach the dashboard frame, start by fitting the two **lower control arm brackets (3J)** into the **chassis (25A)** and secure them using two **BM** screws.

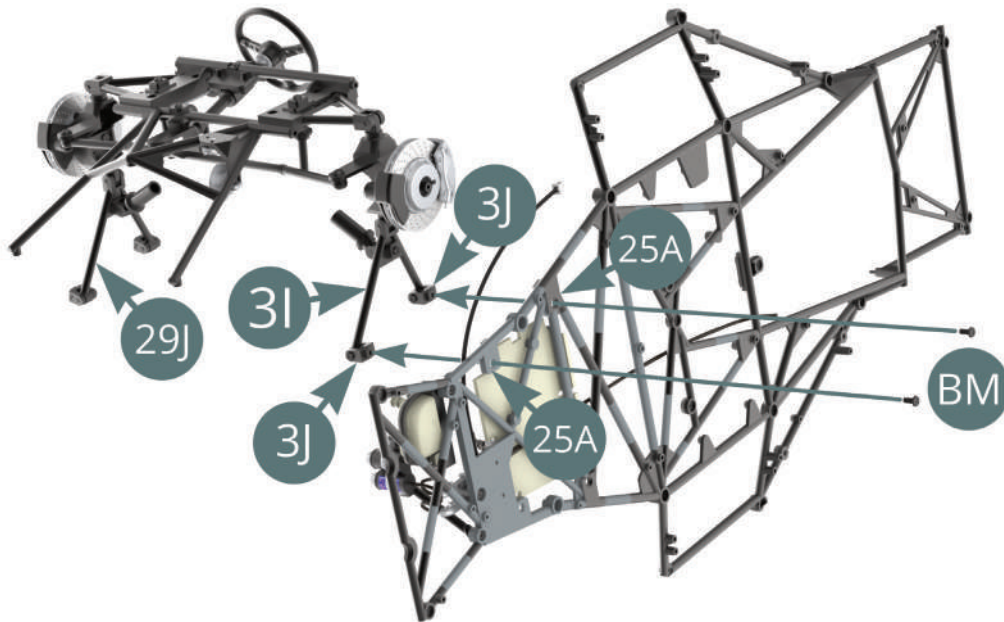

For the next two sections of this step, the two shock absorber springs (**29E and 3D**) are interchangeable. You can use either spring when instructed.

Fit the **shock absorber spring (29E)** over the **shock absorber cylinder (29F)**. Tilt the assembly (green arrow) to fit the **shock absorber piston (29D)** through the spring and into the cylinder (blue arrow).

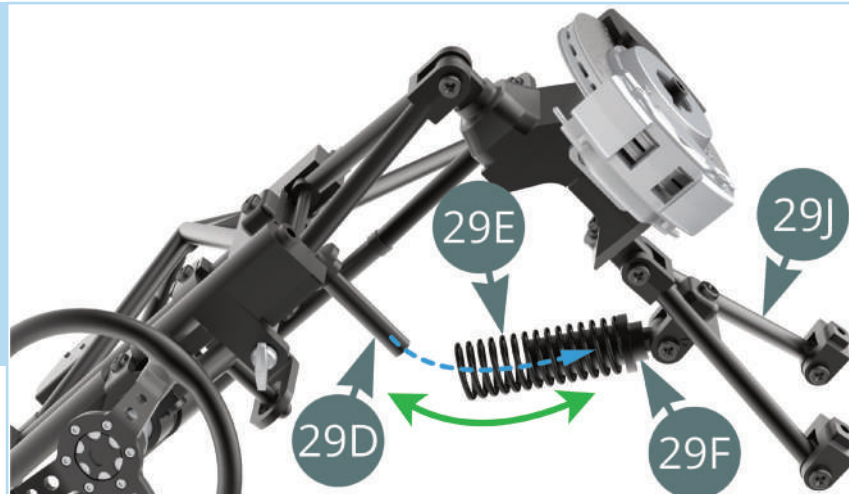

STAGE 30: FITTING THE BRAKES, STEERING AND FRONT SUSPENSION

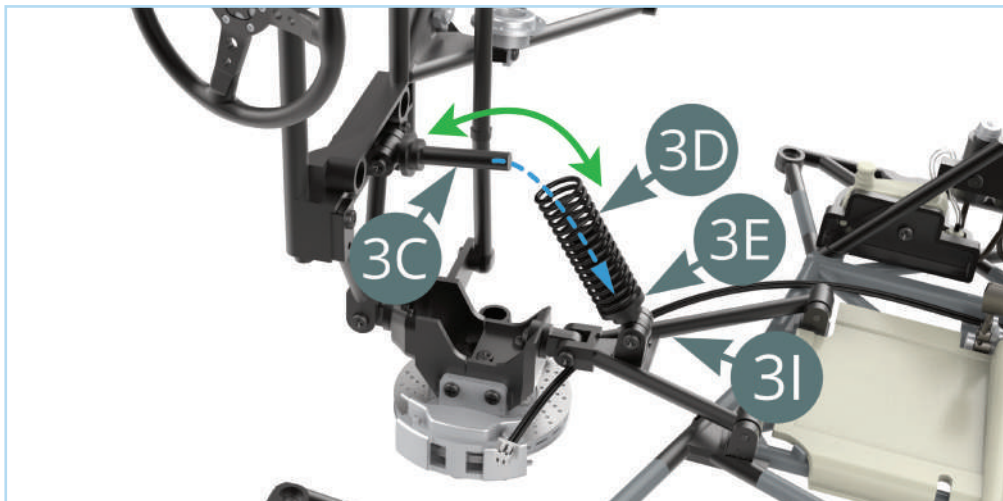

Fit the other **shock absorber spring (3D)** over the **shock absorber cylinder (3E)**. Tilt the assembly (green arrow) to fit the **shock absorber piston (3C)** through the spring and into the cylinder (blue arrow).

At the same time, fit the two arms of the **dashboard frame (27A)** (blue arrows) and the two **lower control arm brackets (29K)** (red arrows) into the corresponding holes in the **chassis (25A)**.

Note there is also a pin on the V-frame (orange arrow) that the dashboard frame will connect with. Take care not to damage or knock off the brake fluid tanks attached to the V-frame while positioning the dashboard frame!

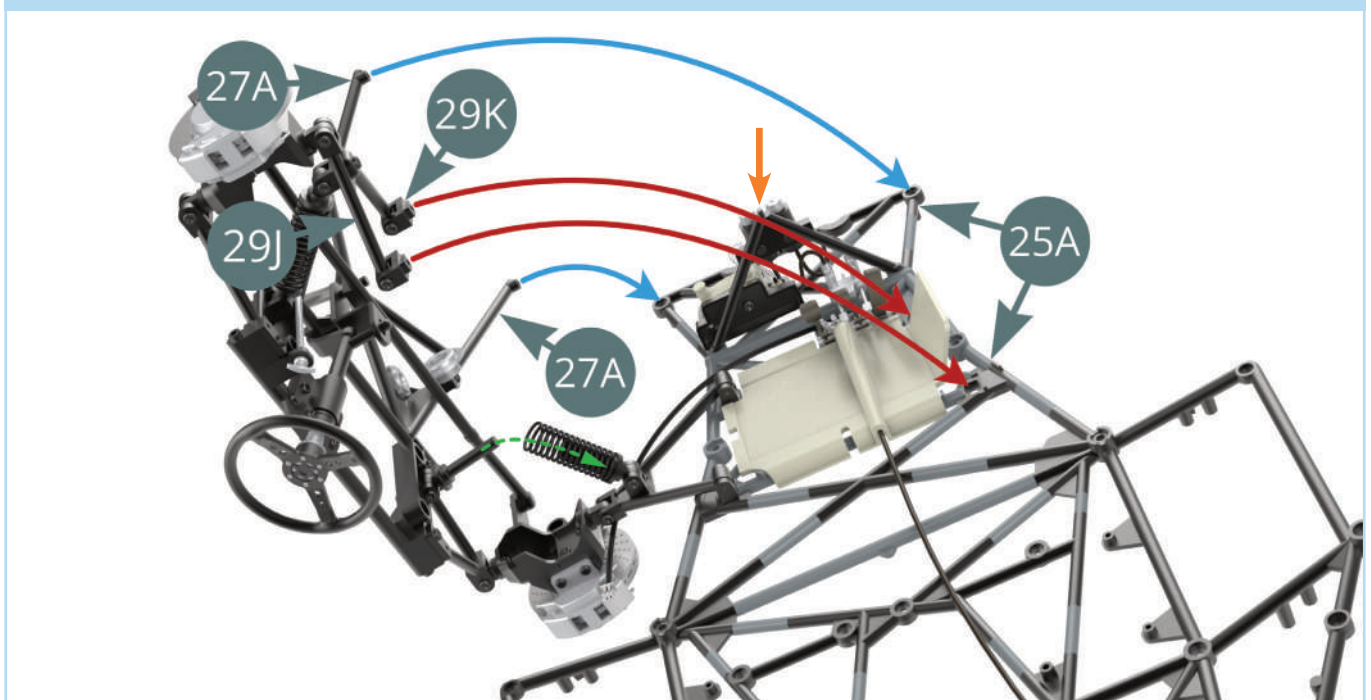

STAGE 30: FITTING THE BRAKES, STEERING AND FRONT SUSPENSION

STEP 8

Attach the arms of the **dashboard frame (27A)** to the **chassis (25A)** using two **BM** screws.

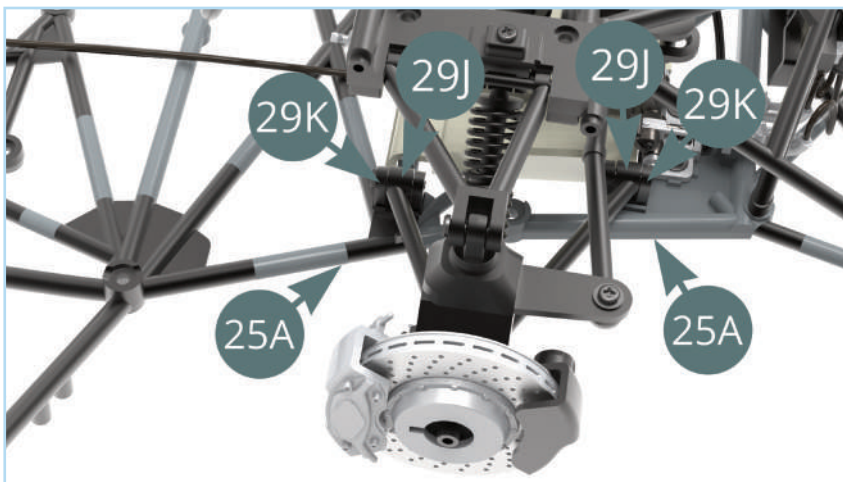
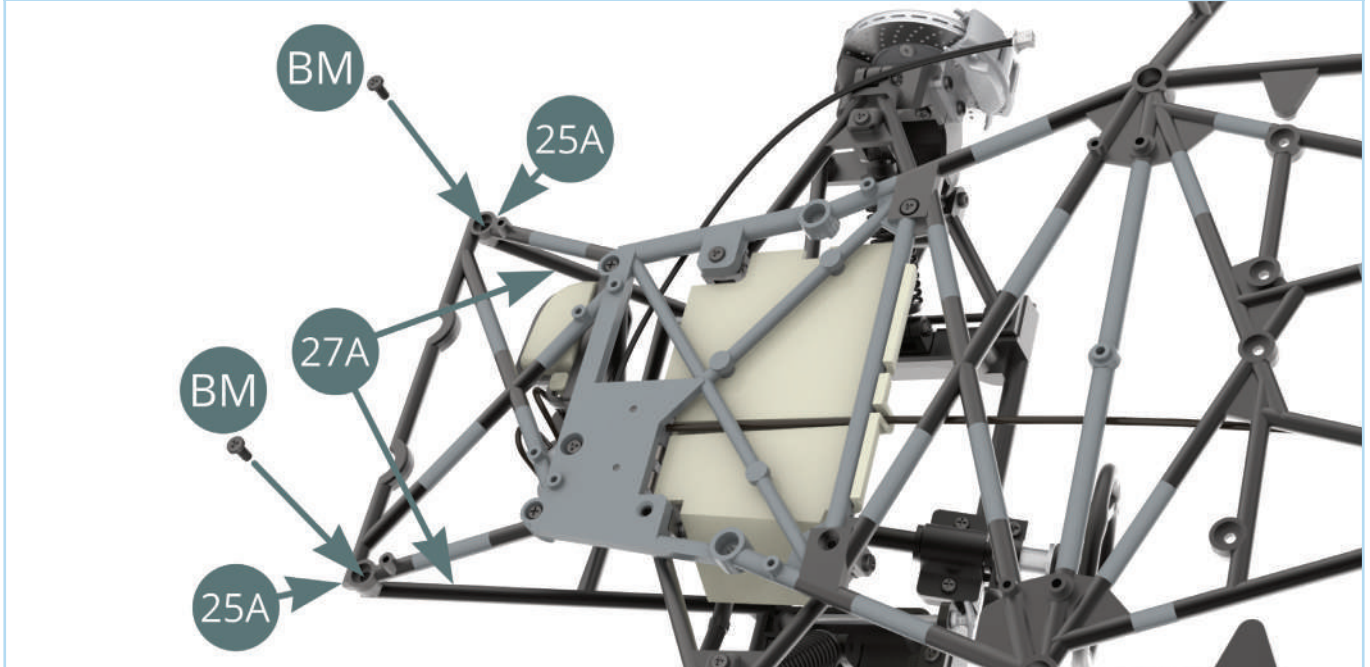

Check that the two **lower control arm brackets (29K)** are located properly in the holes of the **chassis (25A)**.

Attach the **lower control arm brackets (29K)** to the chassis using two **BM** screws.

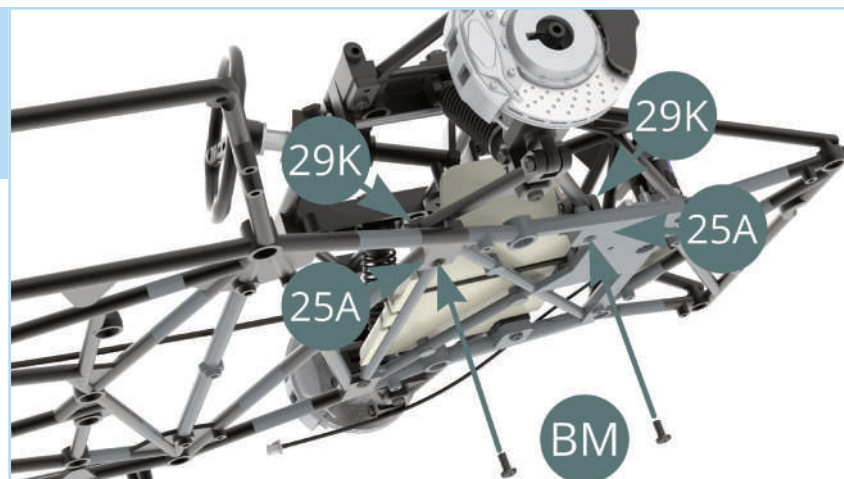

STAGE 30: FITTING THE BRAKES, STEERING AND FRONT SUSPENSION

The dashboard frame has now been connected onto the chassis.



STAGE COMPLETE

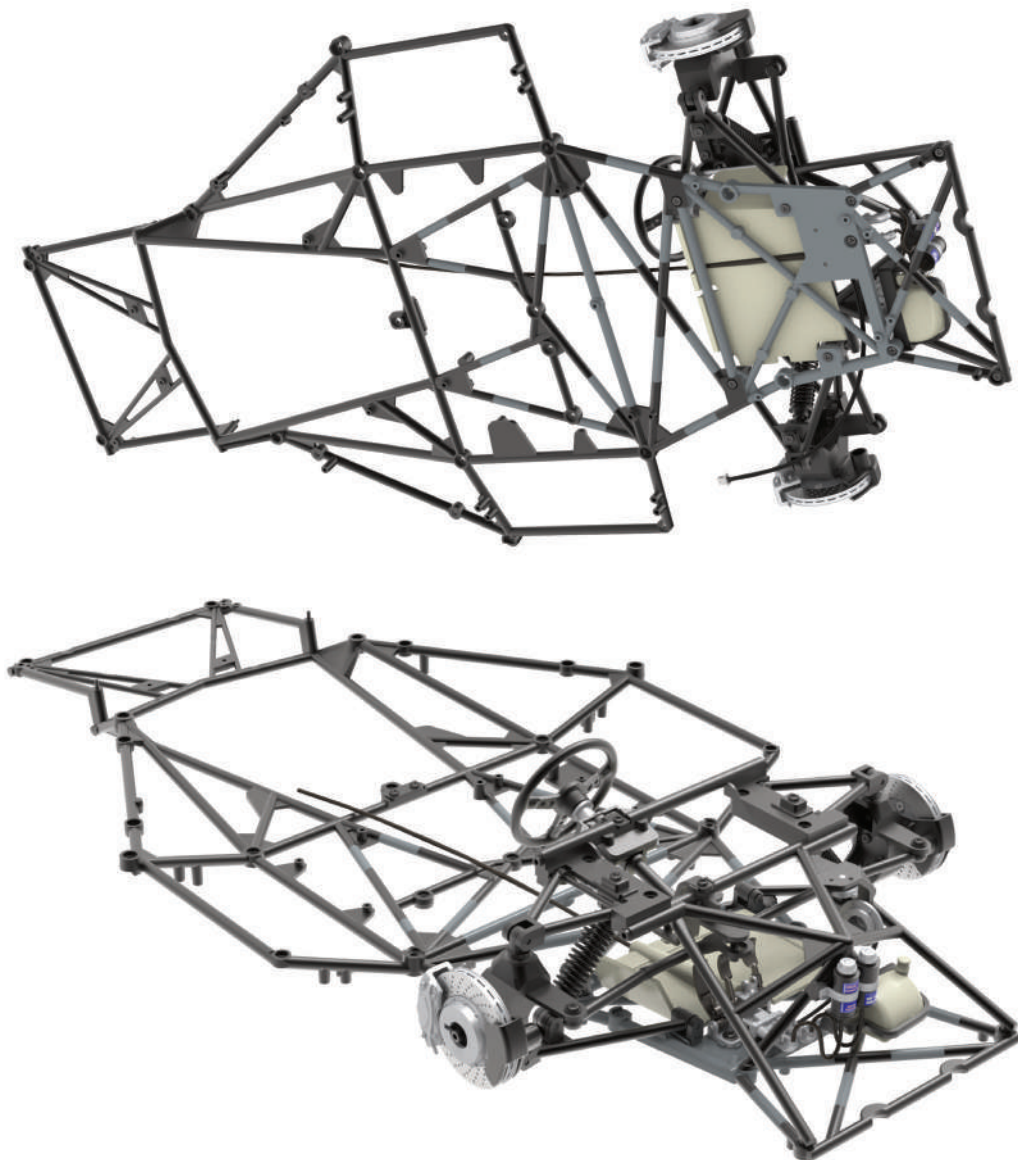

STAGE 31: ADDING THE LEFT COCKPIT TUBULAR FRAME TO THE CHASSIS

31A Tubular frame

31B Tubular frame

31C Wiring board

BM Screw 2.0 x 4 mm (x5)

IM Screw 1.7 x 3.5 mm (x5)

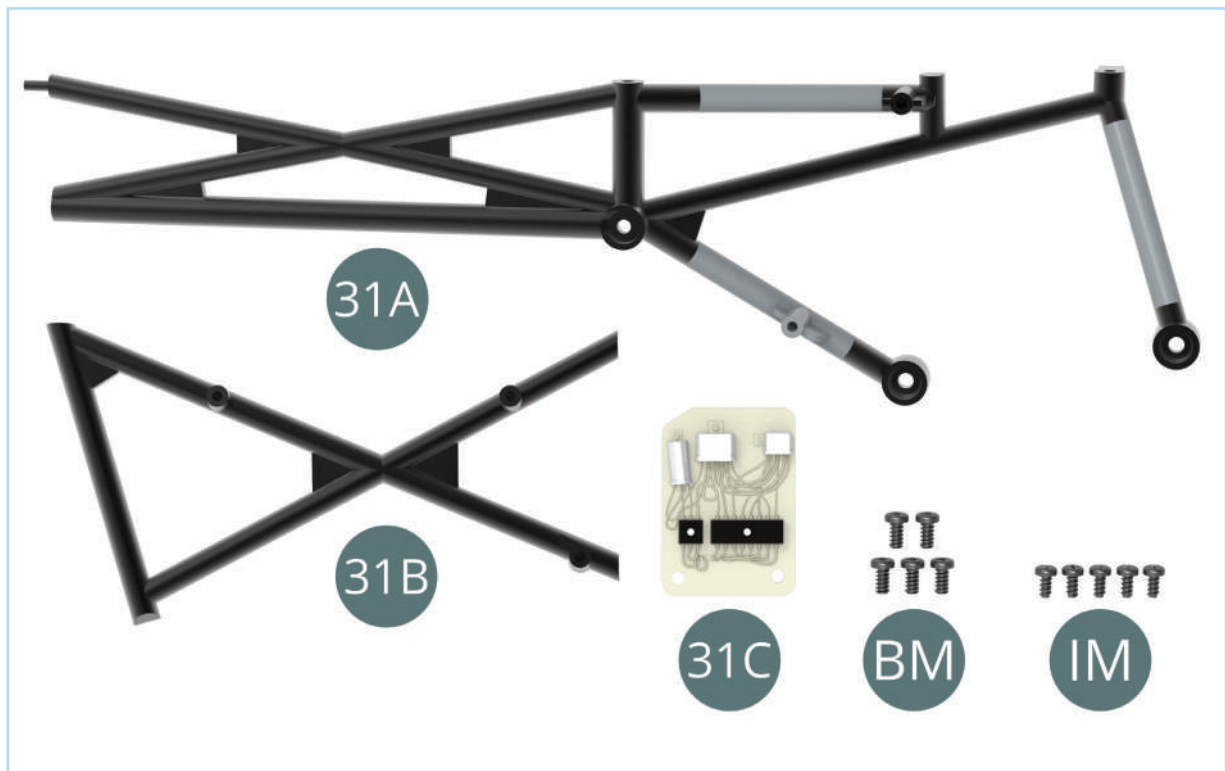

ASSEMBLY DIAGRAM



STAGE 31: ADDING THE LEFT COCKPIT TUBULAR FRAME TO THE CHASSIS

STEP 1

Fit the **wiring board (31C)** onto the larger **tubular frame (31A)** as shown. Attach the board in place using two **IM** screws.

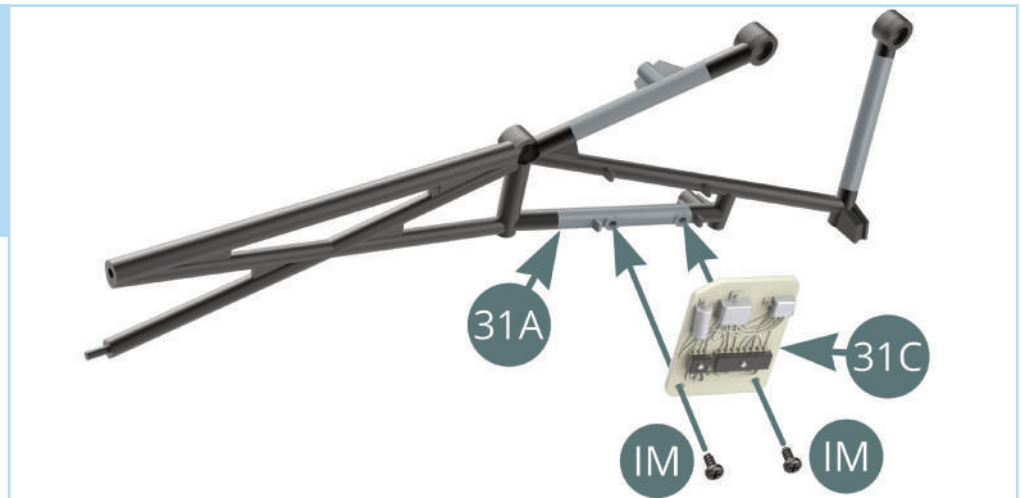

Take the smaller **tubular frame (31B)** and align it with the assembly as shown. Fit it in place and secure the parts together using an **IM** screw.

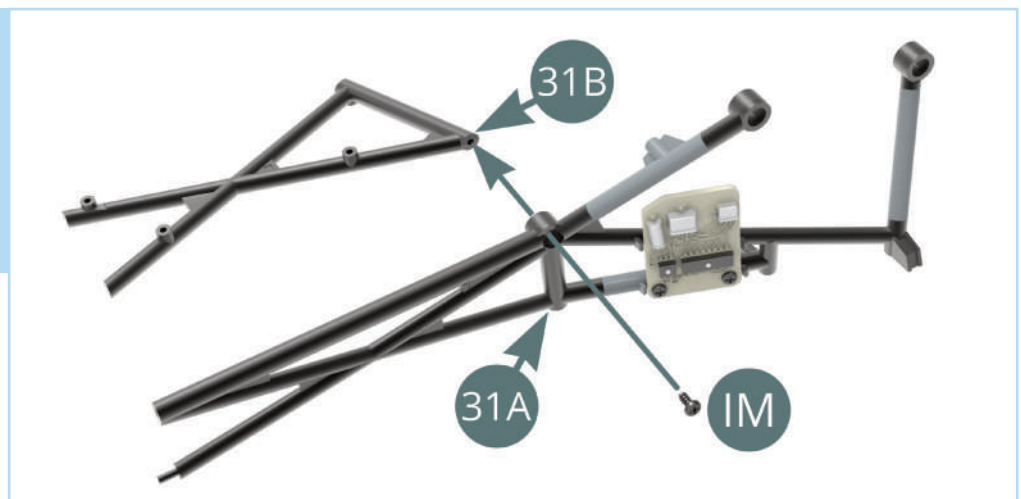

The tubular frame assembly, made up of the frame parts and wiring board, should look like this.

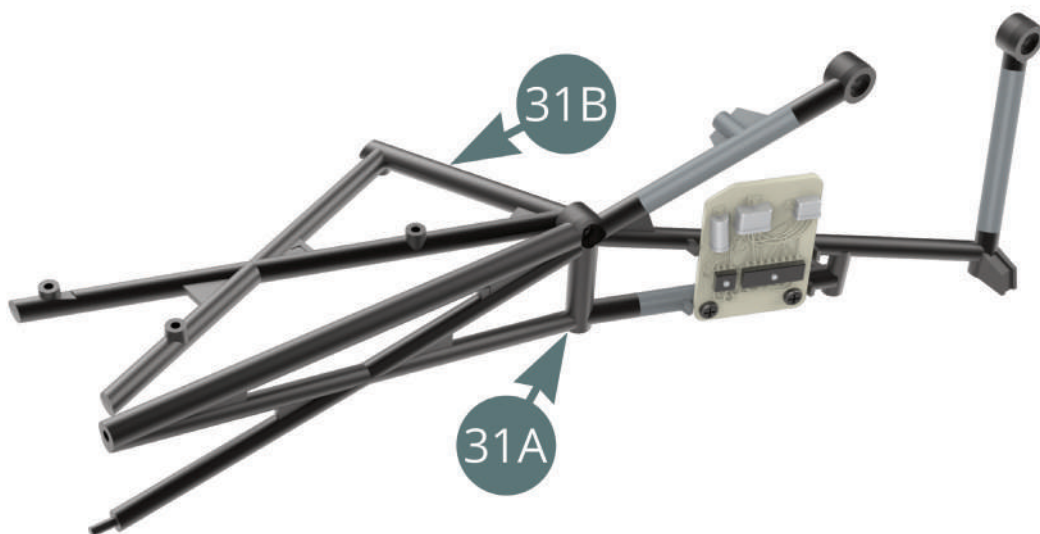

STAGE 31: ADDING THE LEFT COCKPIT TUBULAR FRAME TO THE CHASSIS

STEP 2

Fit the tubular frame assembly onto the **chassis (25A)** (blue arrows) and **dashboard frame (27A)** (red arrow).

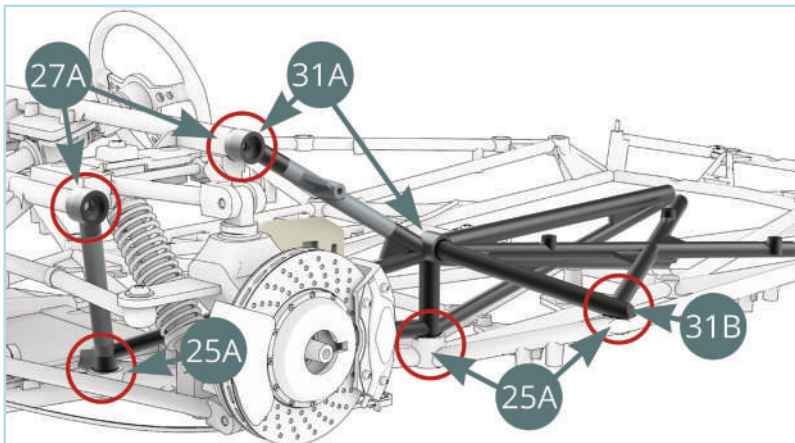
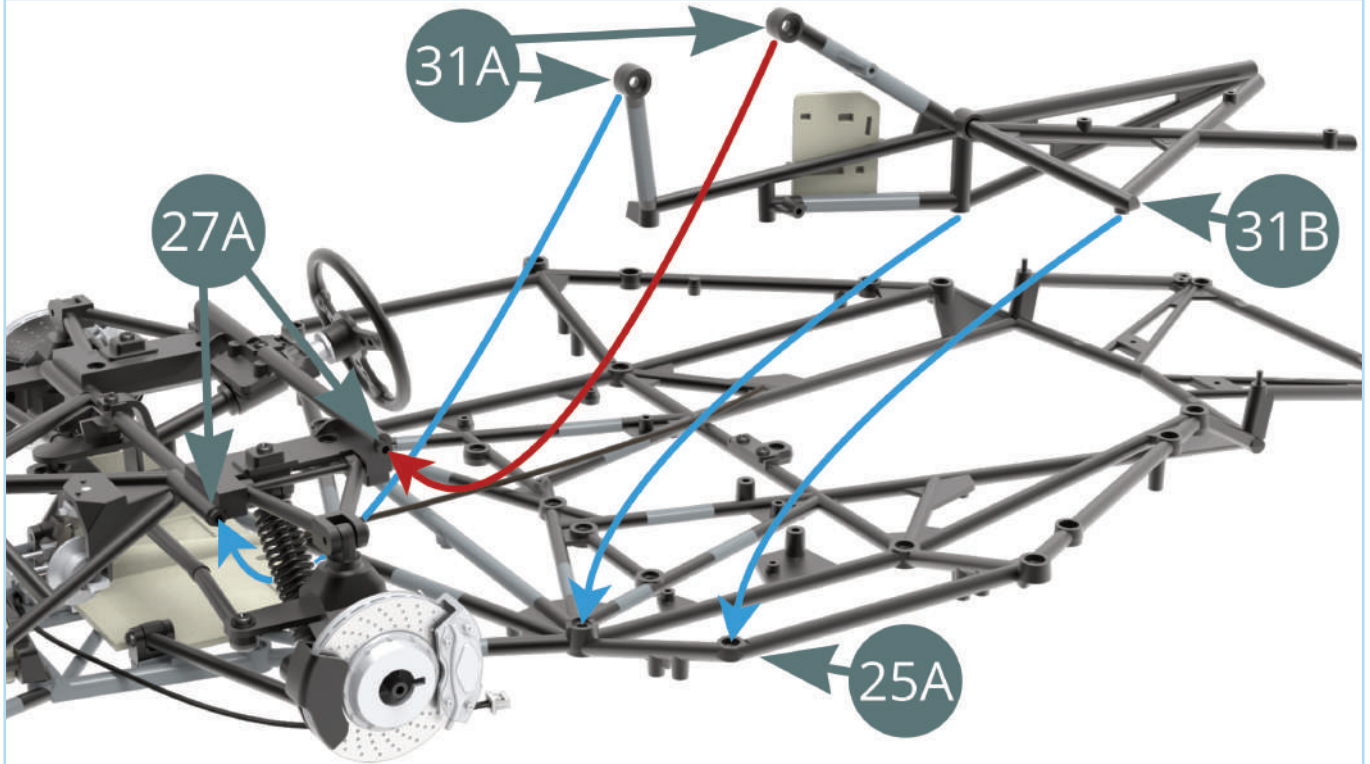

Using the images opposite, locate the five connection points (red circles) between the two assemblies. Ensure that each point is connected properly before proceeding. In the next step, these points will be fixed with their respective screws.

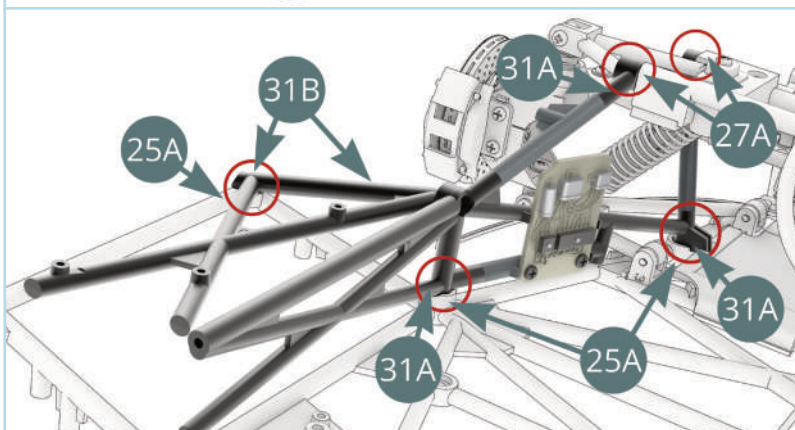

STAGE 31: ADDING THE LEFT COCKPIT TUBULAR FRAME TO THE CHASSIS

STEP 3

Fix the two connection points between the **tubular frame (31A)** and the **dashboard frame (27A)** using two **BM** screws.

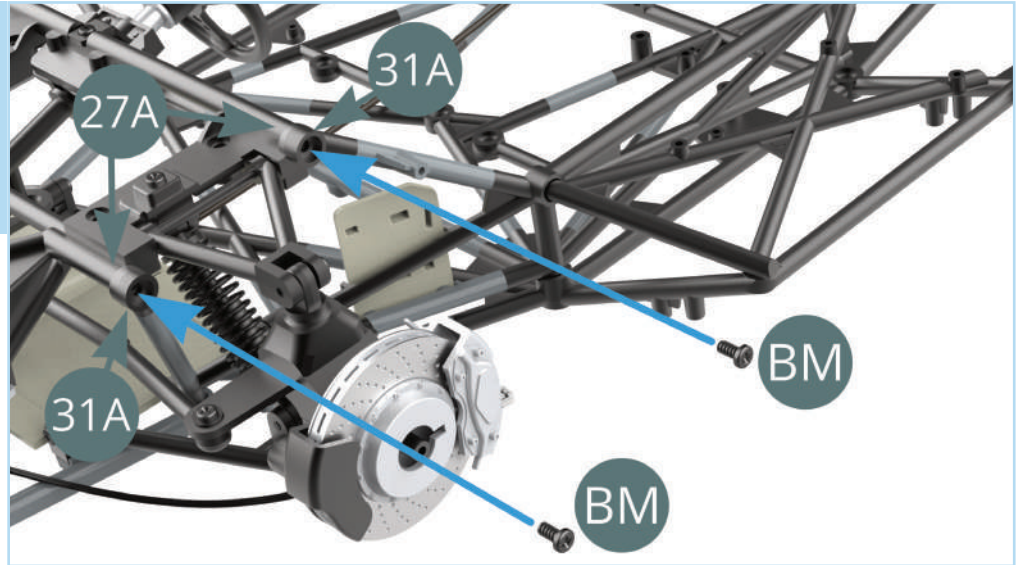

Press the **tubular frame (31A)** down onto the **chassis (25A)** and drive two **BM** screws into the two connection points located underneath the assembly.

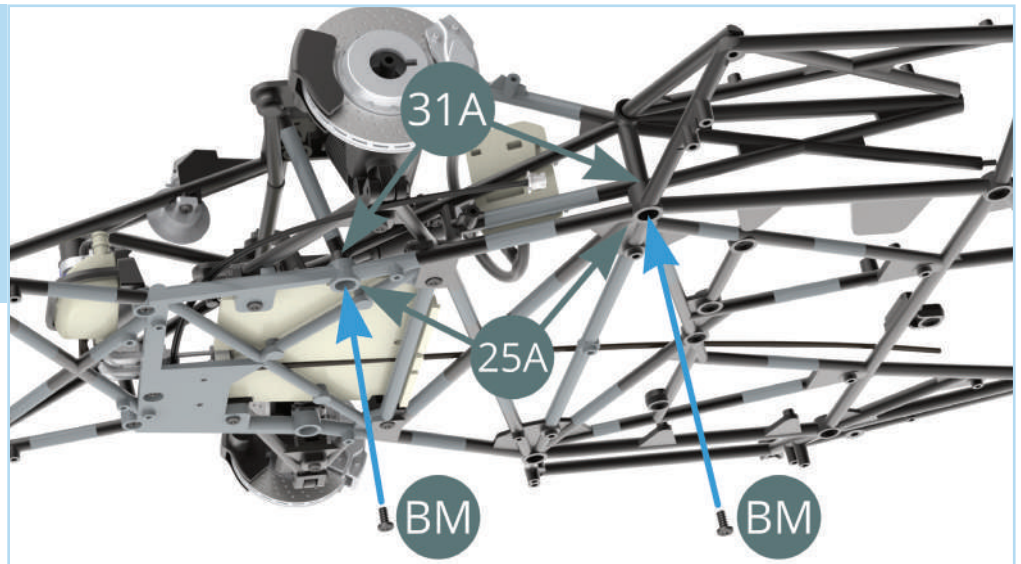

Finally, use one **IM** screw to secure the connection point between the smaller **tubular frame (31B)** and the **chassis (25A)**.

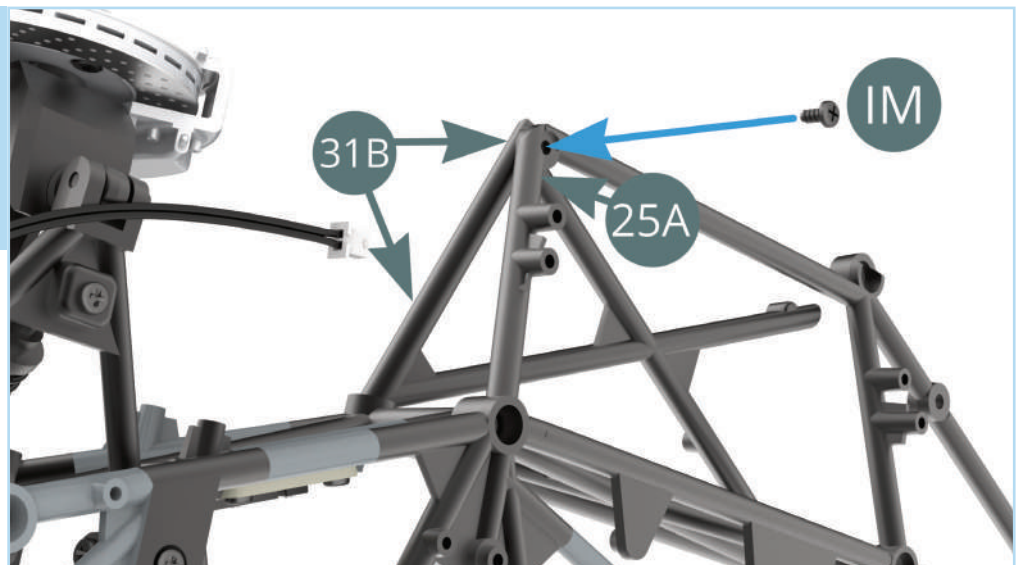

STAGE 31: ADDING THE LEFT COCKPIT TUBULAR FRAME TO THE CHASSIS

STAGE COMPLETE

Tip: Check the steering of your model by turning the steering wheel. If any of the parts are not fixed in place fully, loosen the corresponding screw(s), add a drop of oil then tighten the screw.

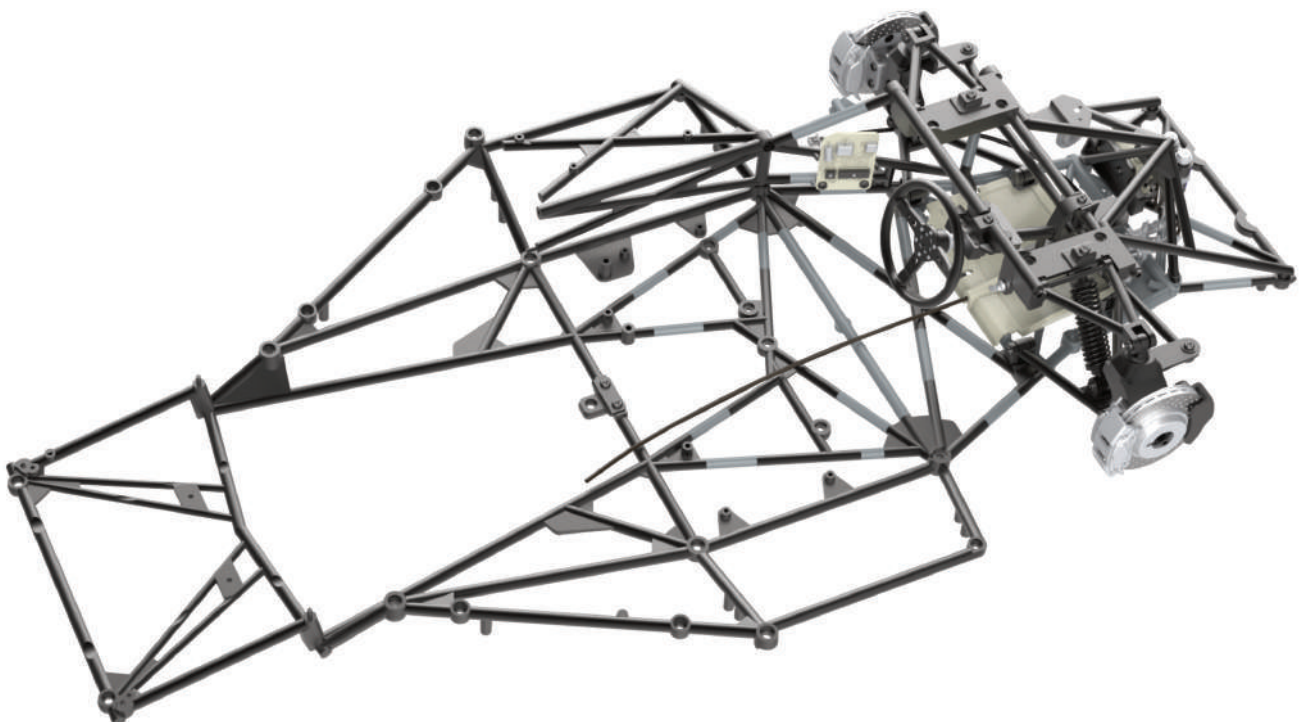
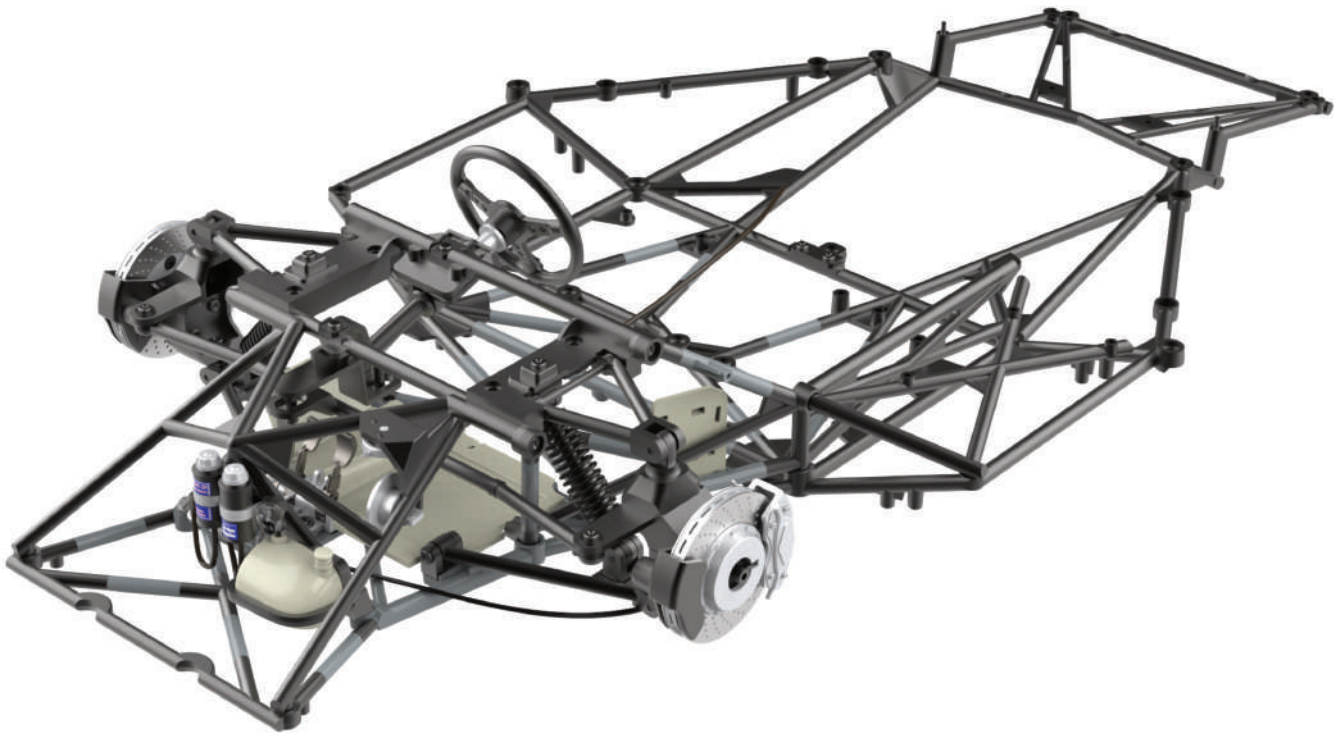

STAGE 32: ATTACHING THE LEFT FUEL TANK WITH THE CIRCUIT BOARD

32A Left fuel tank top

32B Left fuel tank bottom

32C Filling pipe/neck

32D Circuit board with wires

32E Washer (x4)

BP Screw 1.7 x 4 x 5 mm (x5)

CM Screw 2.0 x 3 x 5 mm (x2)

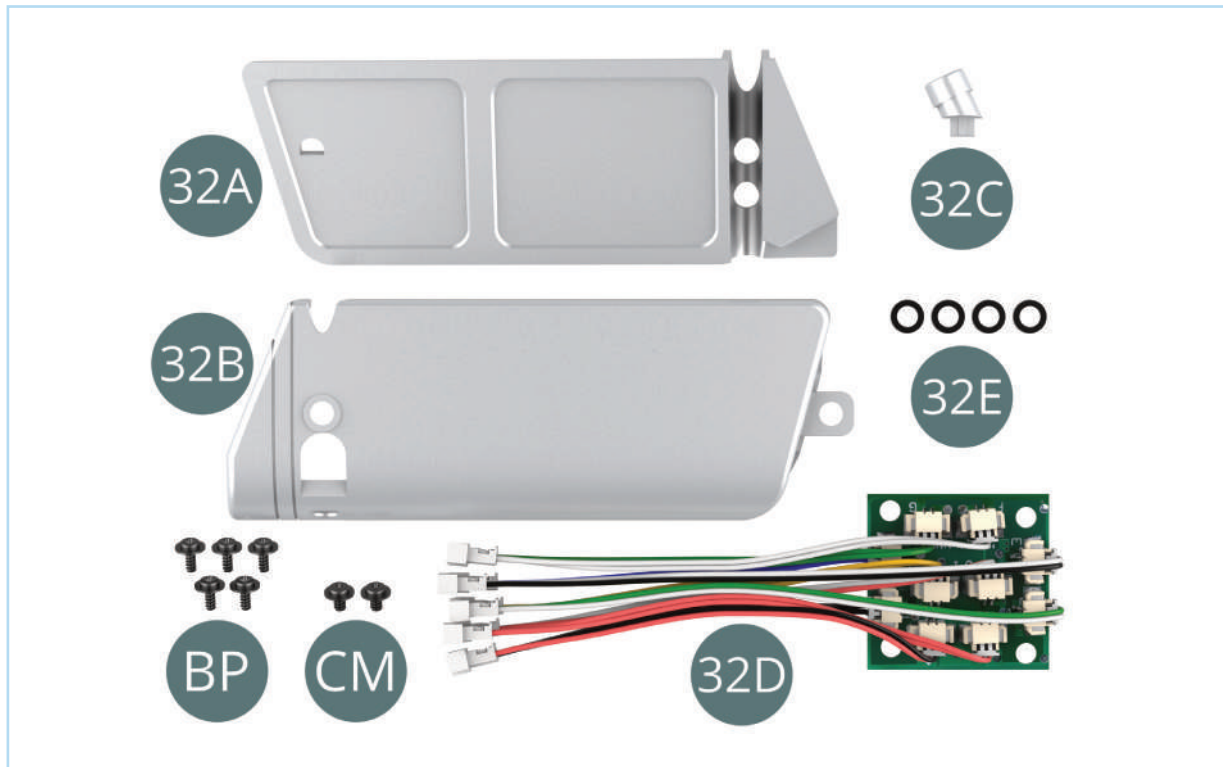

ASSEMBLY DIAGRAM

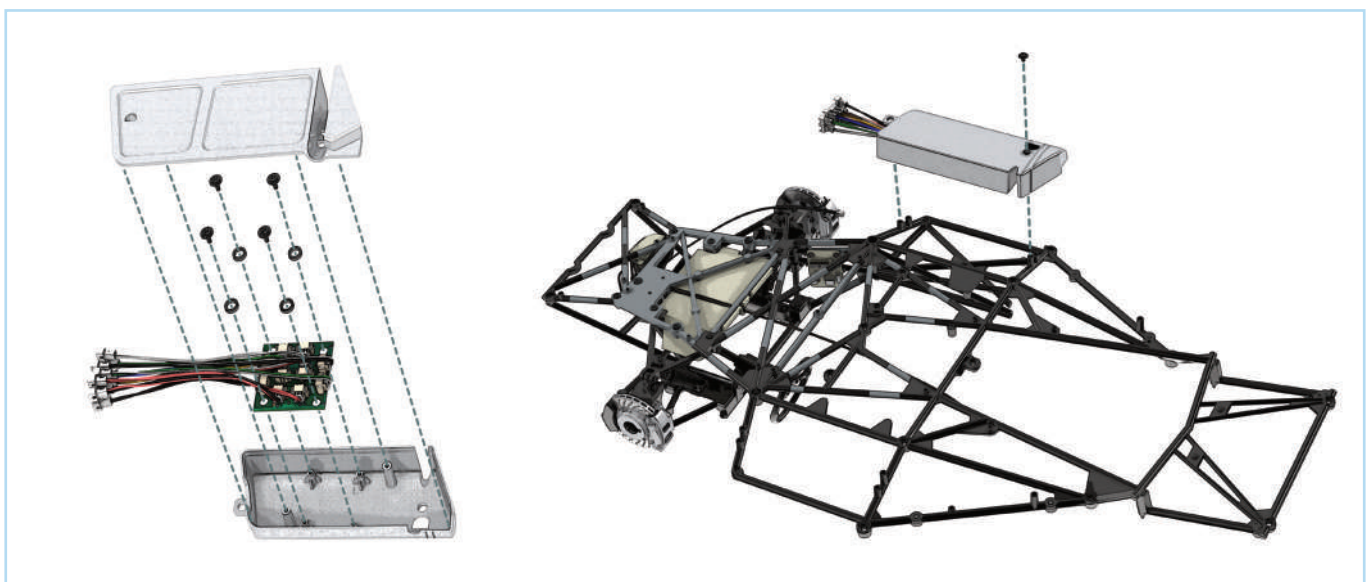

STAGE 32: ATTACHING THE LEFT FUEL TANK WITH THE CIRCUIT BOARD

STEP 1

Align the **circuit board with wires (32D)** with the **left fuel tank bottom (32B)** as shown. Press the board in place by fitting the four holes at the edges over the four columns in the tank bottom.

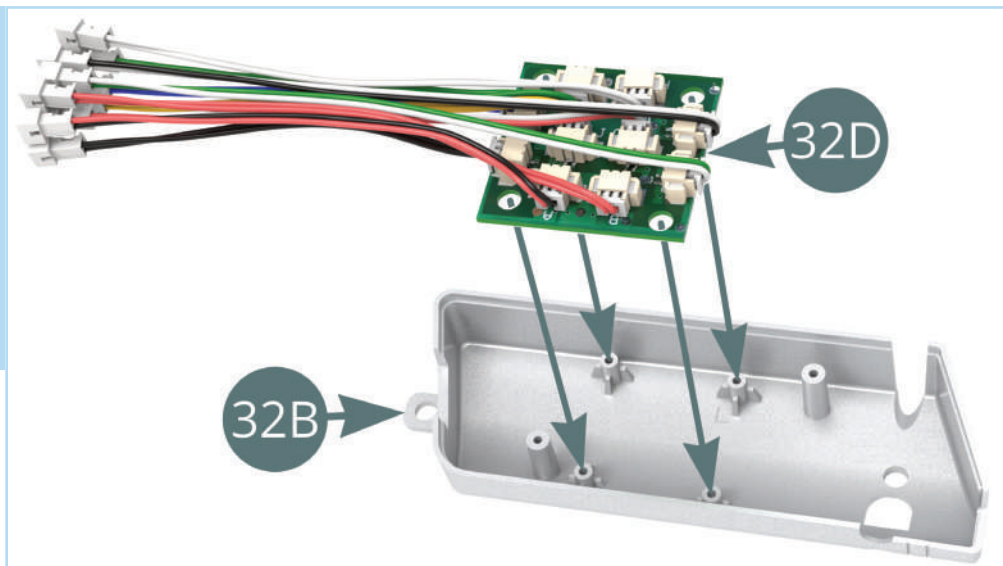

Place a **washer (32E)** over each of the protruding columns.

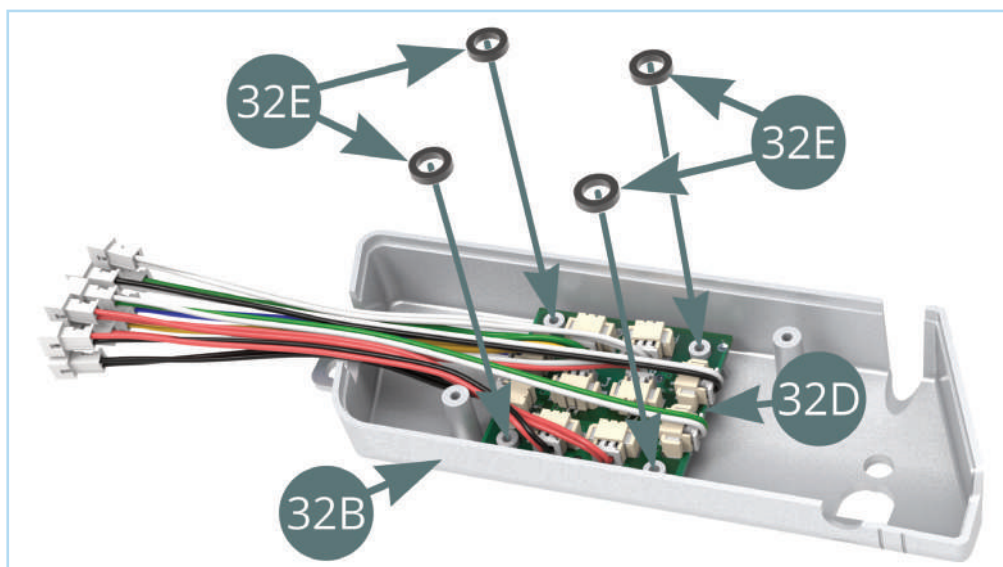

Fix the circuit board in place using four **BP** screws.

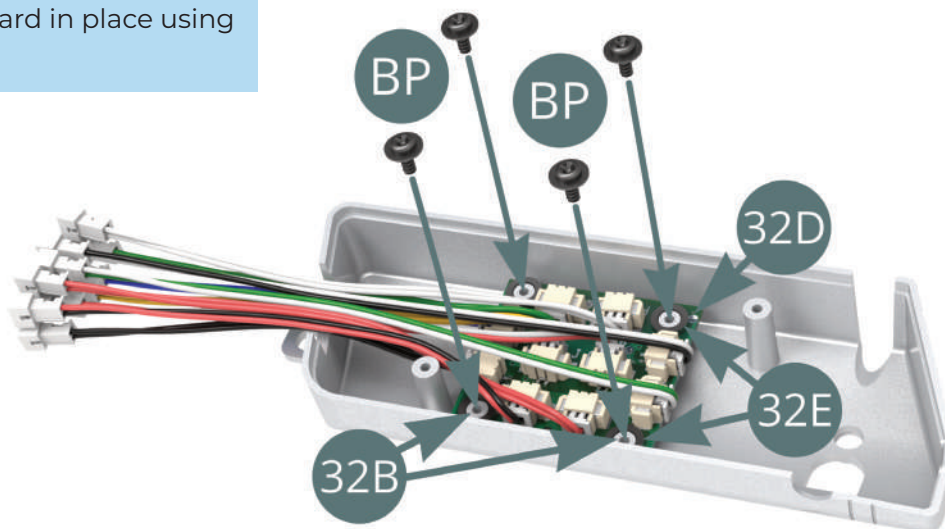

STAGE 32: ATTACHING THE LEFT FUEL TANK WITH THE CIRCUIT BOARD

STEP 2

Fit the **left fuel tank top (32A)** onto the **left fuel tank bottom (32B)**, pushing the connections highlighted by the red arrows firmly in place.

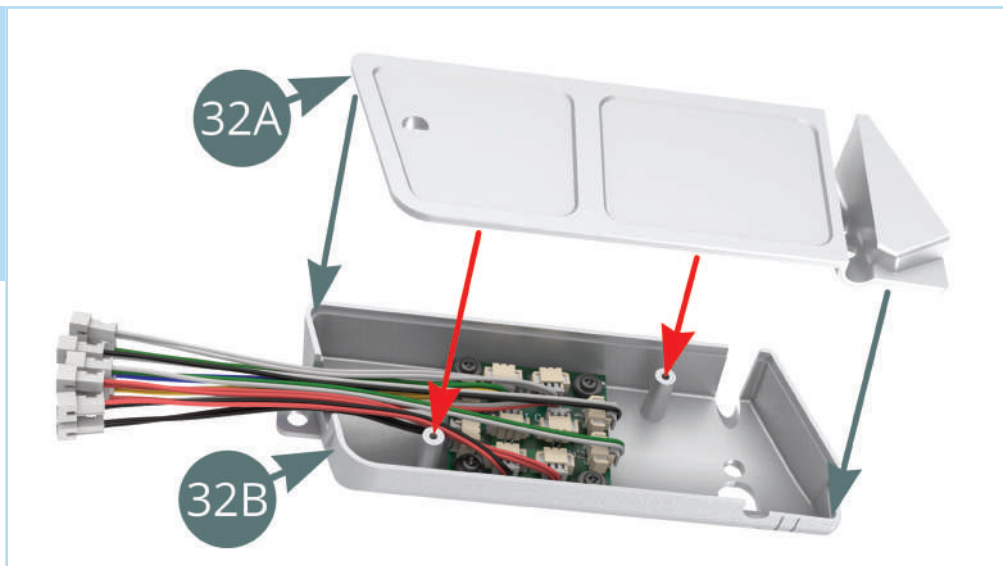

Push the D-shaped lug of the **filling pipe/neck (32C)** into the corresponding hole in the fuel tank top.

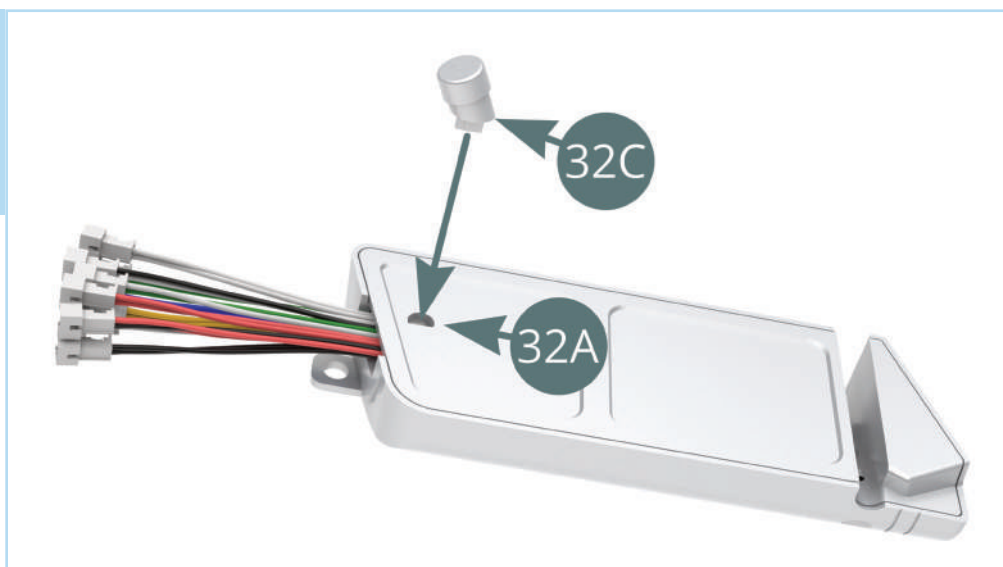

STEP 3

Take the chassis assembly and turn it upside down. Align the left fuel tank with it and fit onto the lugs of the chassis as shown. The wires should be threaded through the gap between the chassis and the tubular frame fitted in the previous stage (red arrow).

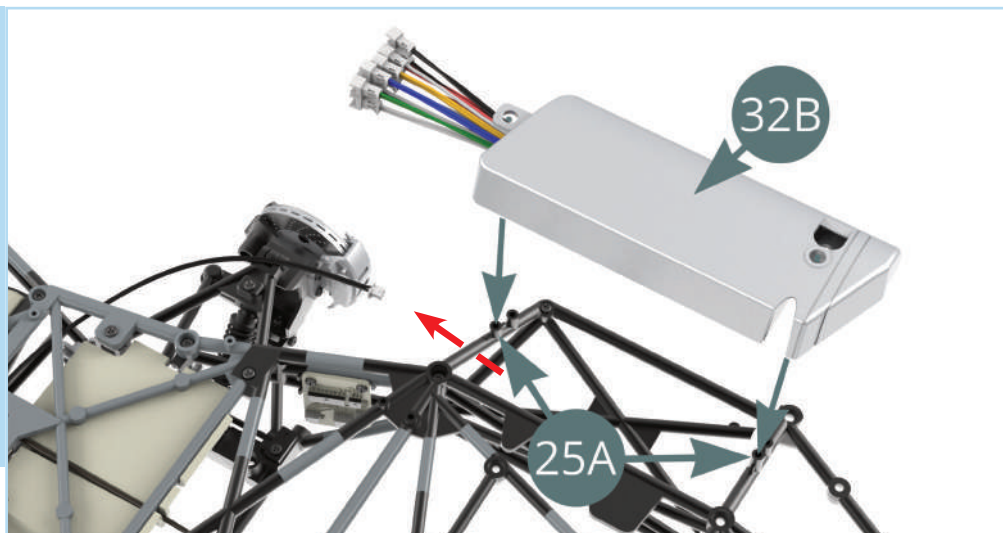

STAGE 32: ATTACHING THE LEFT FUEL TANK WITH THE CIRCUIT BOARD

Drive a **CM** screw into the chassis lug visible at the back of the fuel tank as shown.

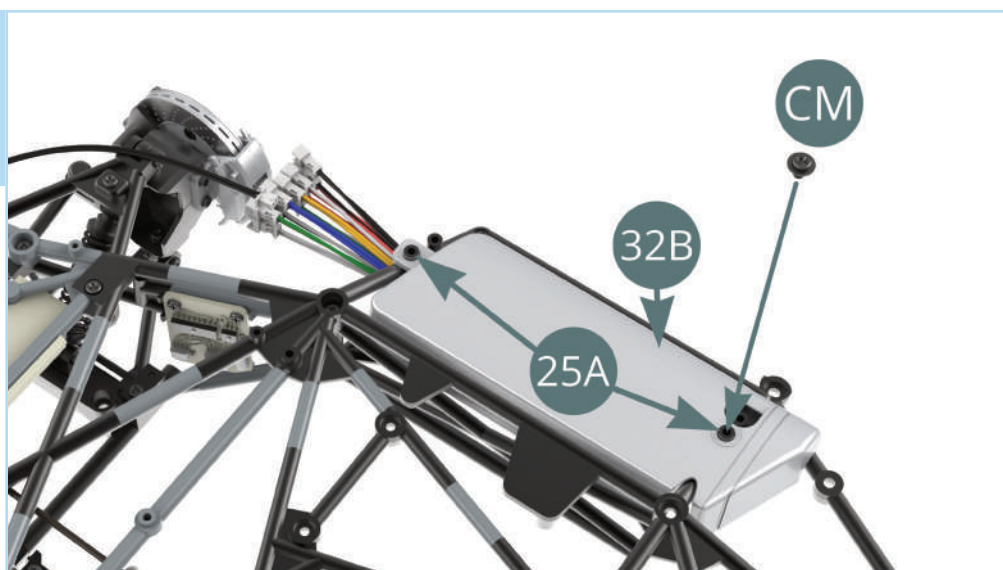

The wires of the circuit board should run between the **chassis (25A)** and the **tubular frame (31B)**.

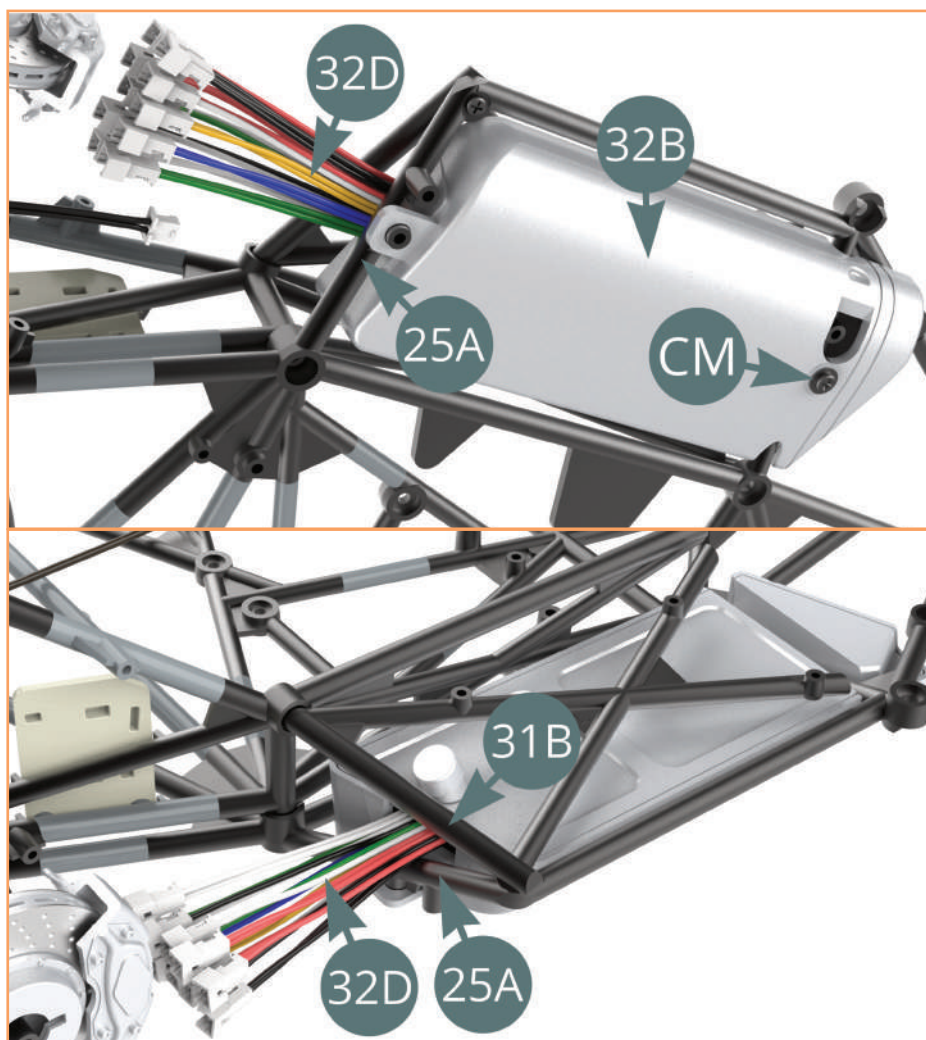

STAGE 32: ATTACHING THE LEFT FUEL TANK WITH THE CIRCUIT BOARD

STAGE COMPLETE

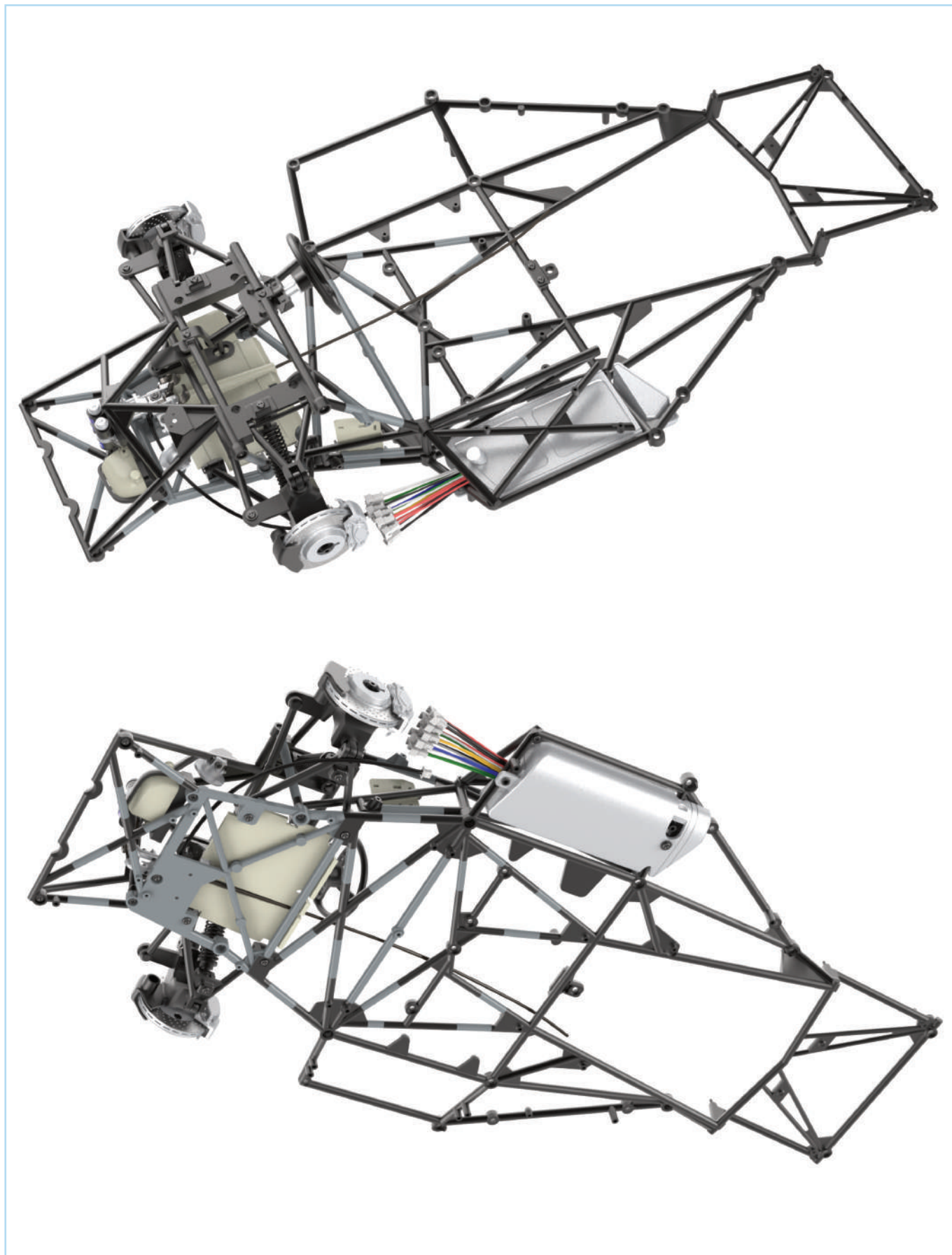

STAGE 33: ATTACHING THE RIGHT FUEL TANK AND CABLES

33A Right fuel tank top

IM Screw 1.7 x 3.5 mm (x2)

33B Right fuel tank bottom

33C Filling pipe/neck

33D Switch cable (red-red)

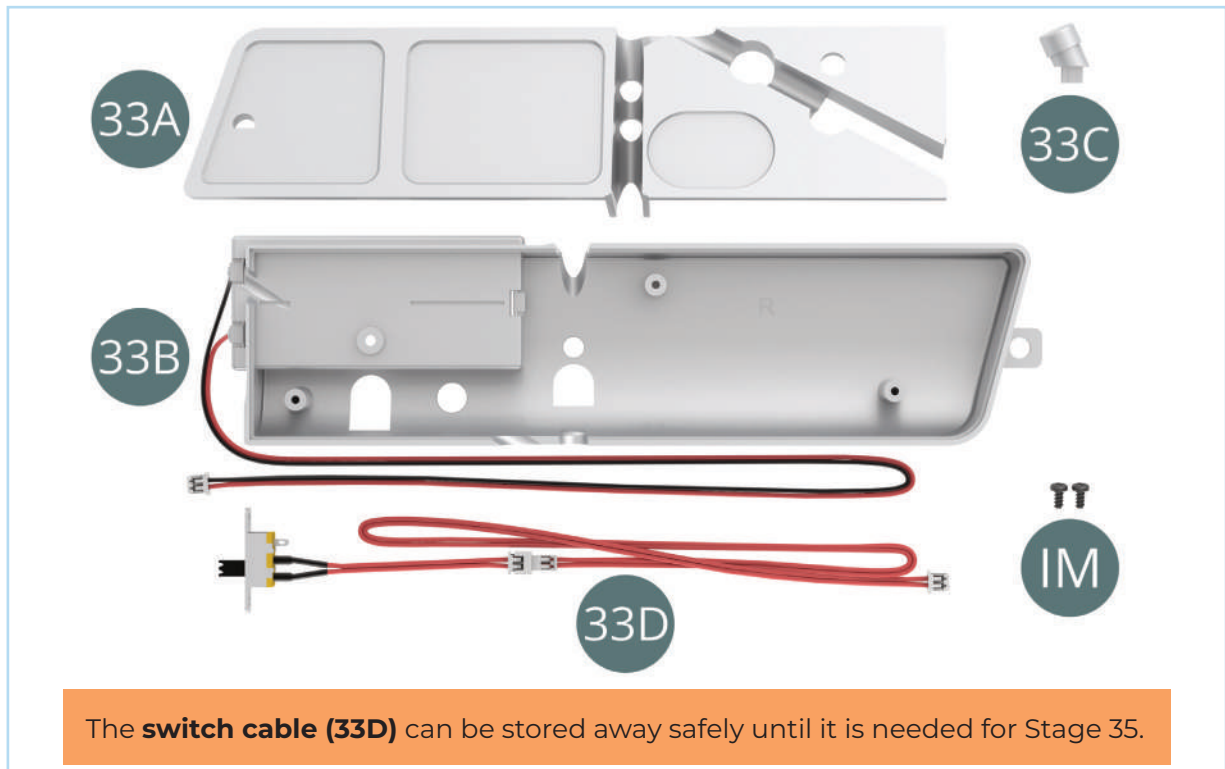

ASSEMBLY DIAGRAM

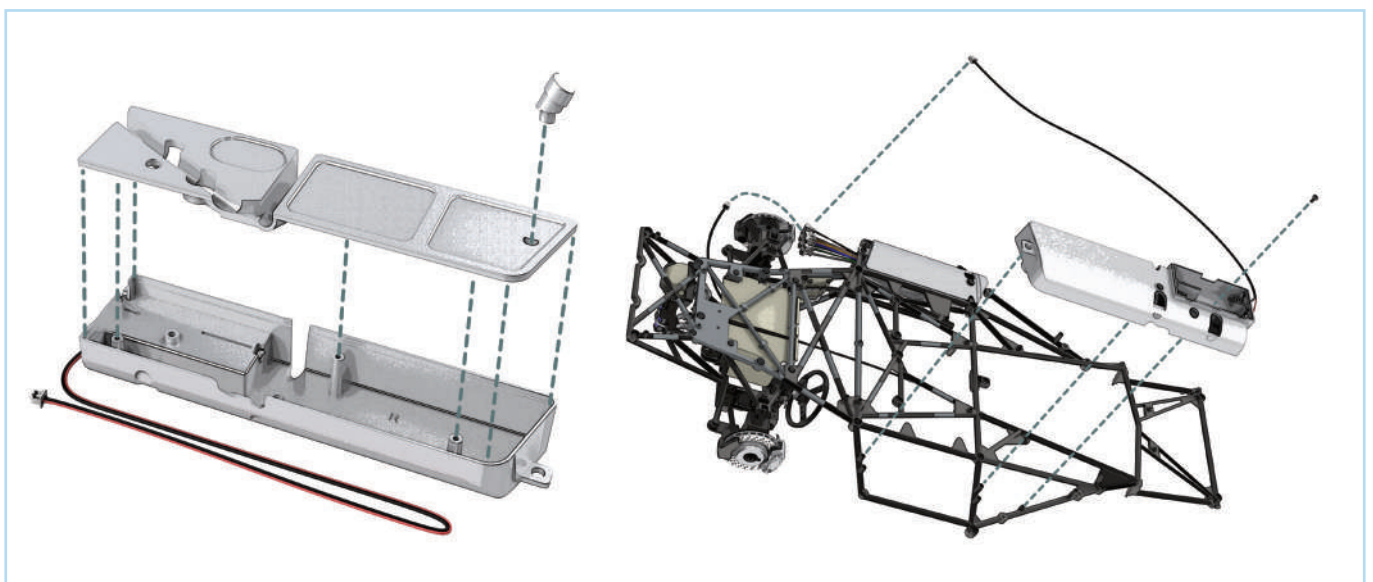

STAGE 33: ATTACHING THE RIGHT FUEL TANK AND CABLES

STEP 1

Align the **right fuel tank top (33A)** with the **right fuel tank bottom (33B)** as shown and push into place using the three pins (red arrows).

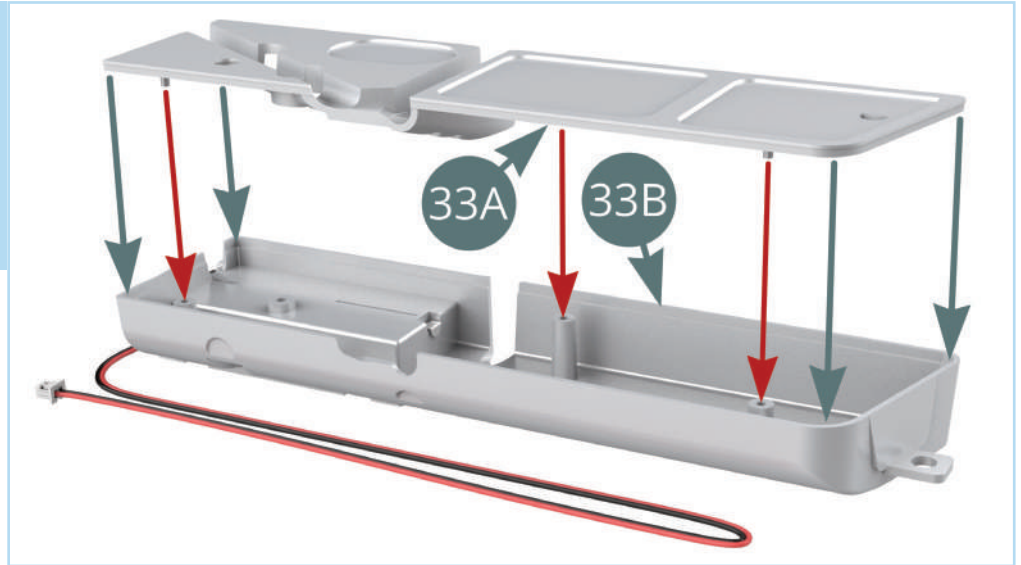

Press the **filling pipe/neck (33C)** into the D-shaped hole in the fuel tank top.

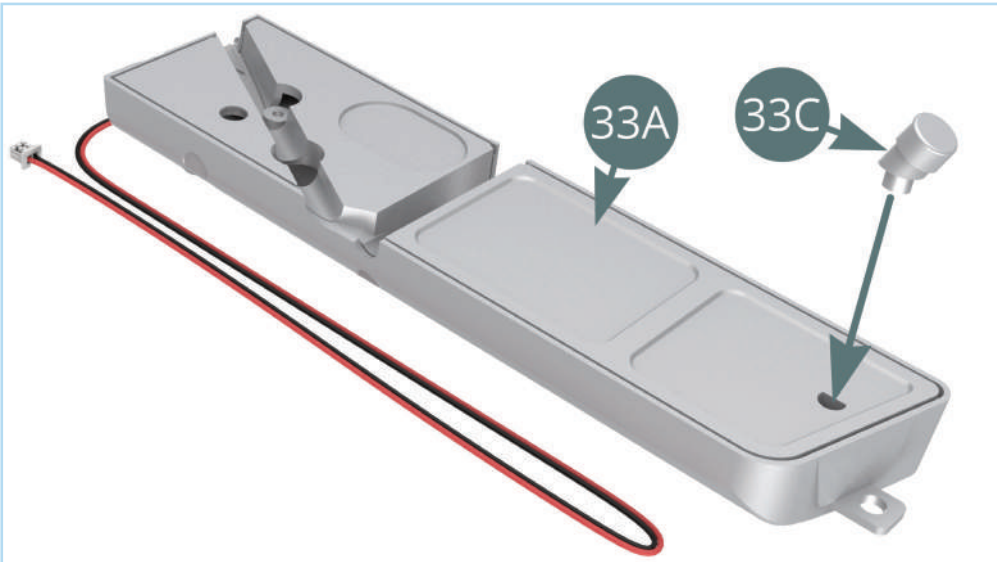

STEP 2

Take the chassis assembly and turn it upside down. Align the right fuel tank with it and fit onto the lugs as shown.

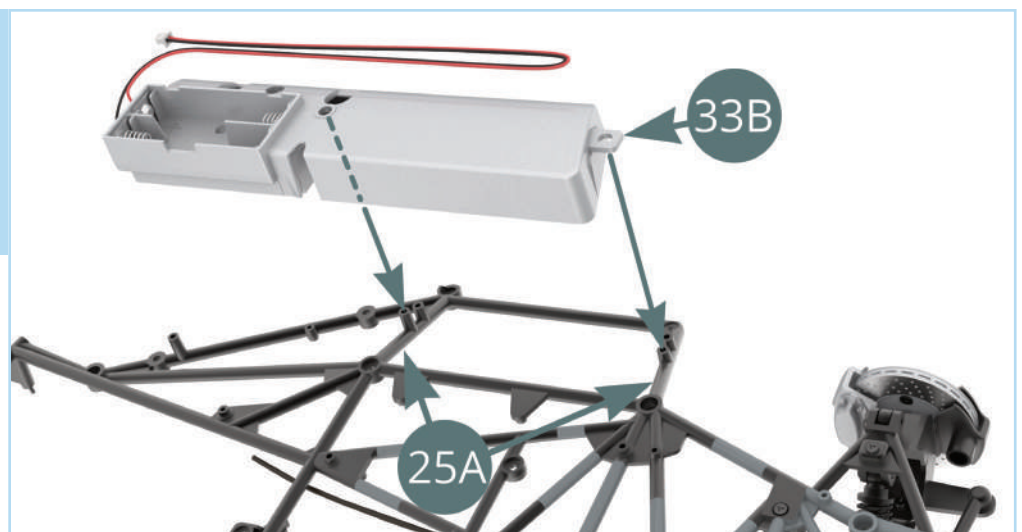

STAGE 33: ATTACHING THE RIGHT FUEL TANK AND CABLES

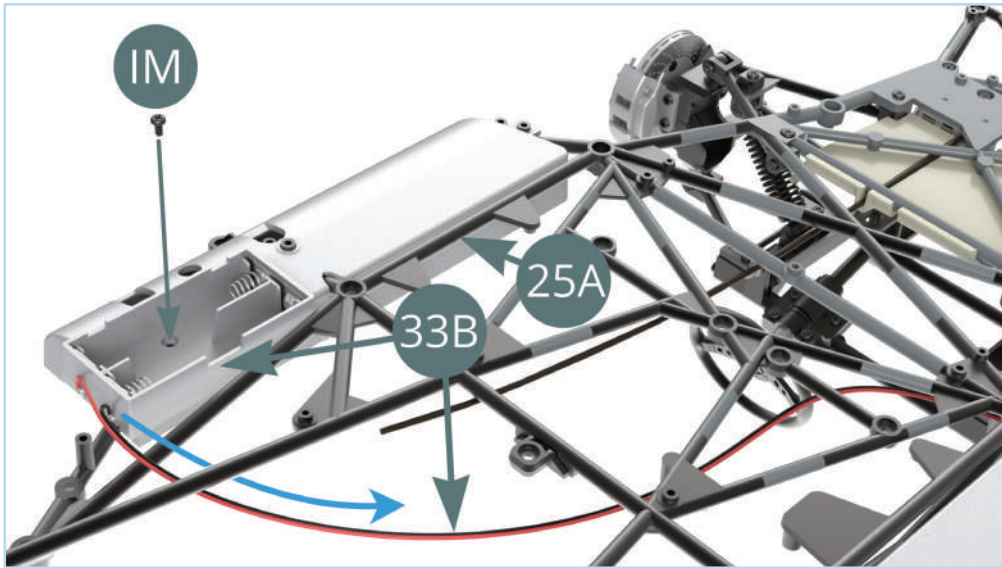

Secure the right fuel tank to the chassis using an **IM** screw.

Route the red and black cable from the fuel tank through the chassis as shown by the blue arrow.

STEP 3

Pass the red and black cable through the tubular frames and connect it to the red and black socket protruding from the left fuel tank (red arrow).

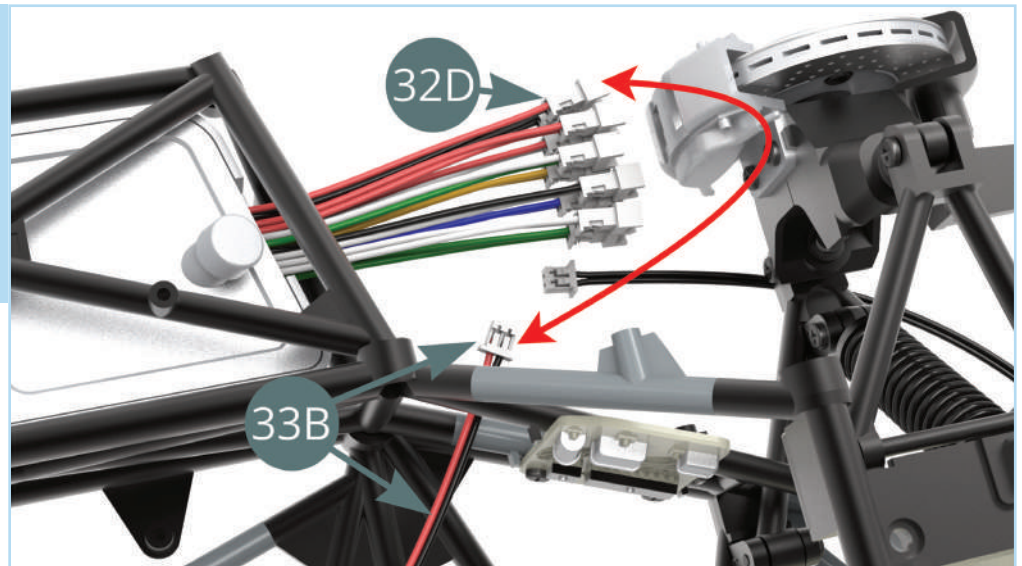

The cables from the left fuel tank (**32D**) and right fuel tank (**33B**) have been connected. Locate the **brake light switch cable (26K)** for the next step.

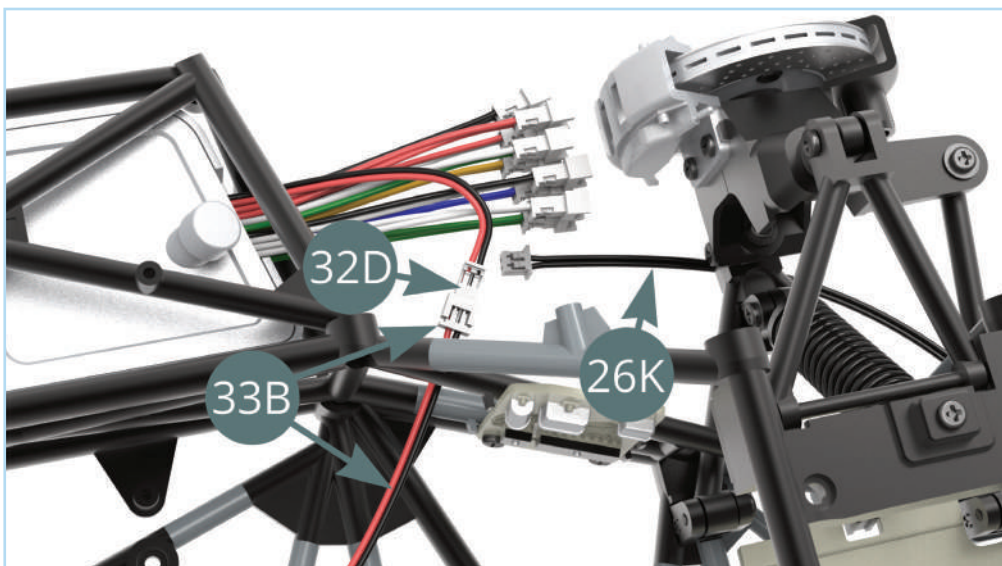

STAGE 33: ATTACHING THE RIGHT FUEL TANK AND CABLES

STEP 4

Guide the black **brake light switch cable (26K)** along the **footrest (26A)** and through the tubular frame as shown. Connect it to the black socket protruding from the left fuel tank.

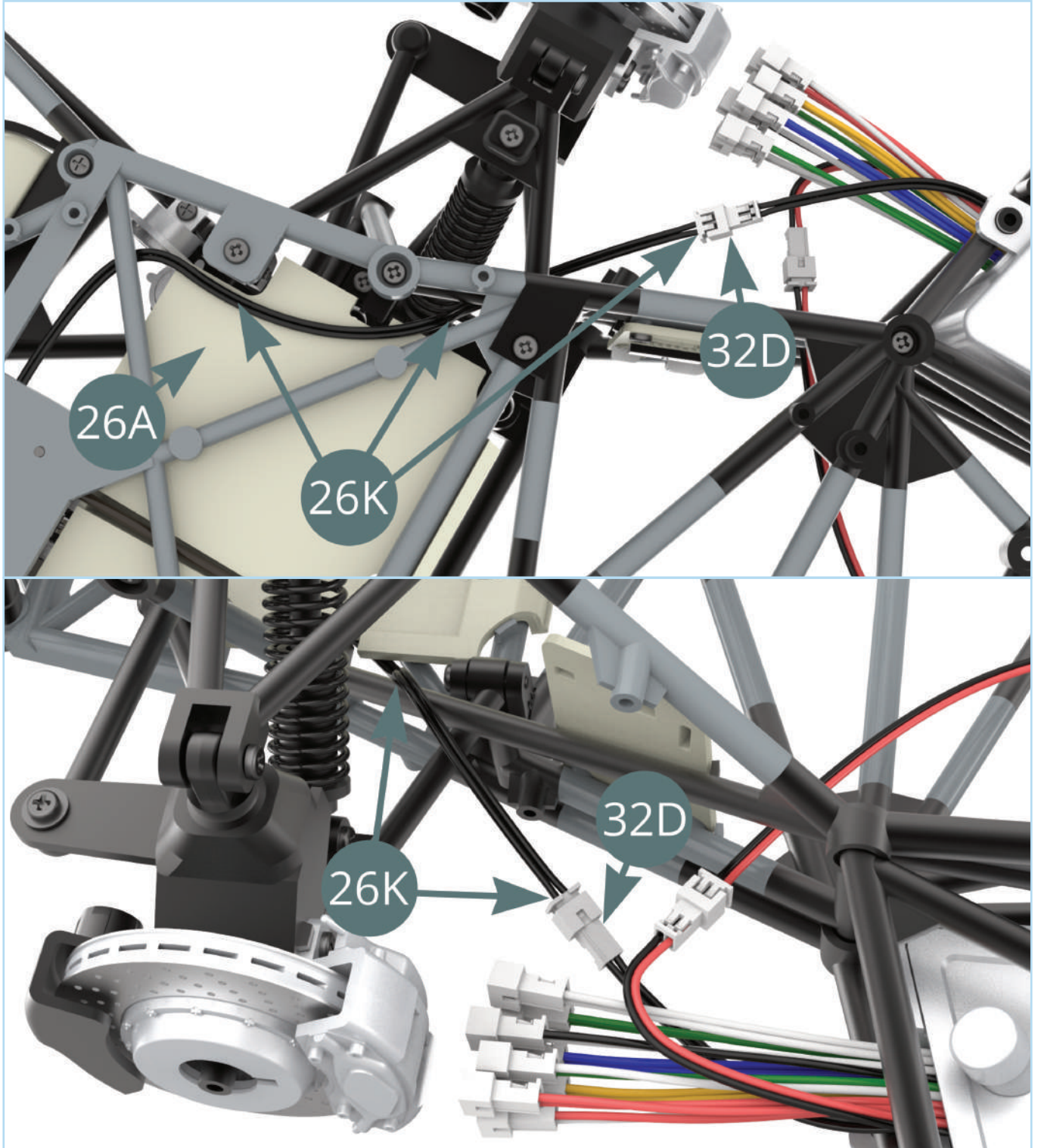

STAGE 33: ATTACHING THE RIGHT FUEL TANK AND CABLES

STAGE COMPLETE

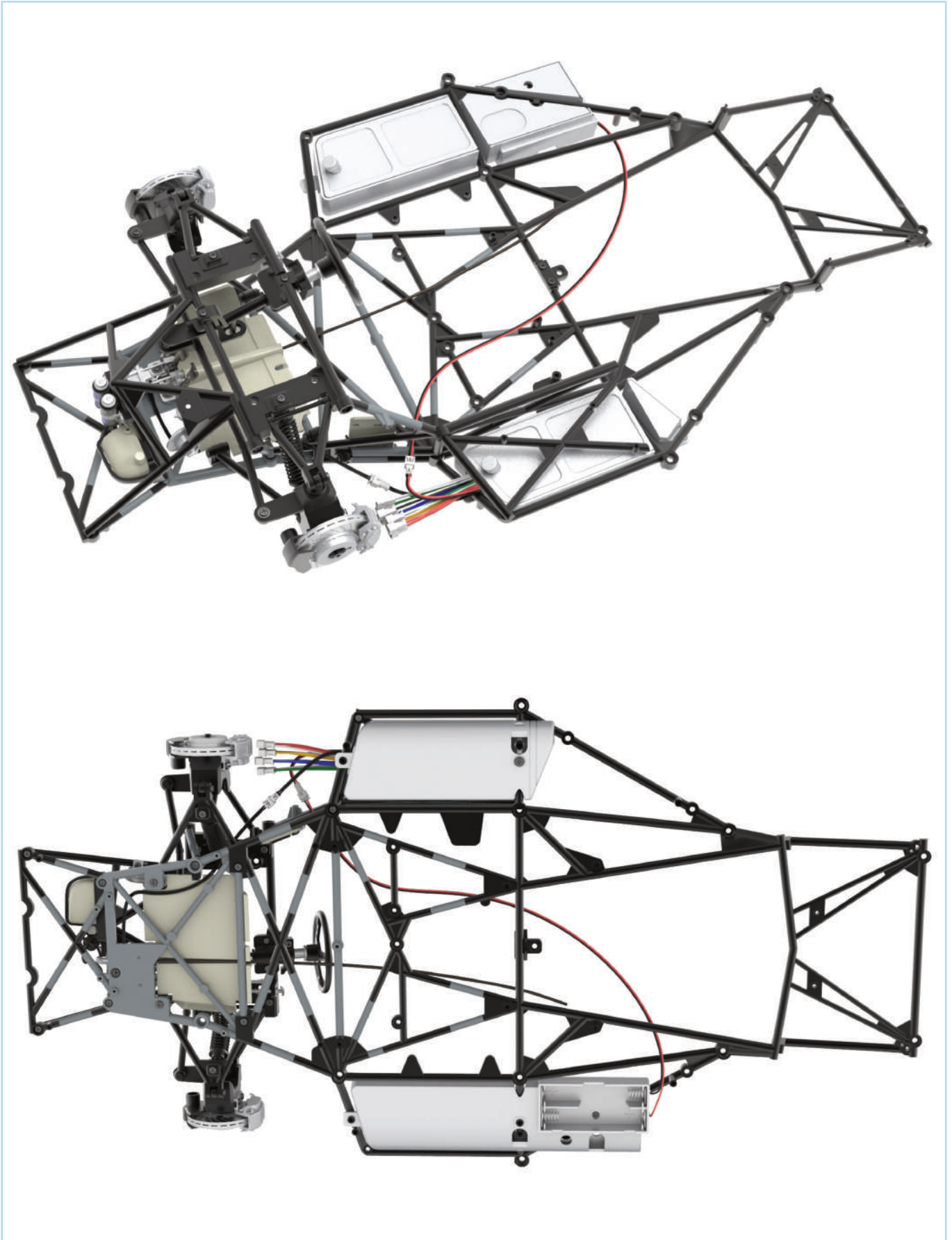

STAGE 34: ADDING THE RIGHT COCKPIT TUBULAR FRAME TO THE CHASSIS

34A Tubular frame

34B Tubular frame

34C Speaker (with yellow cable)

34D Engine sound switch cable (blue)

34E Horn switch cable (green)

BM Screw 2.0 x 4 mm (x5)

IM Screw 1.7 x 3.5 mm (x3)

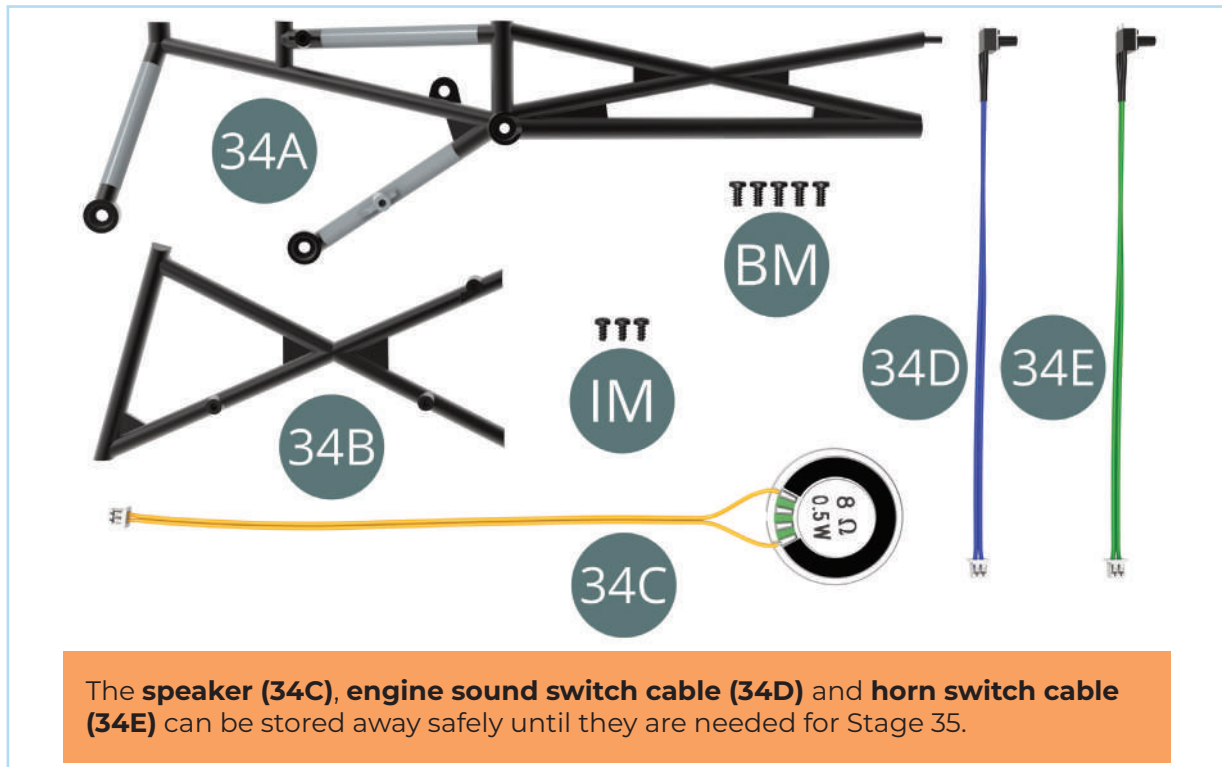

ASSEMBLY DIAGRAM

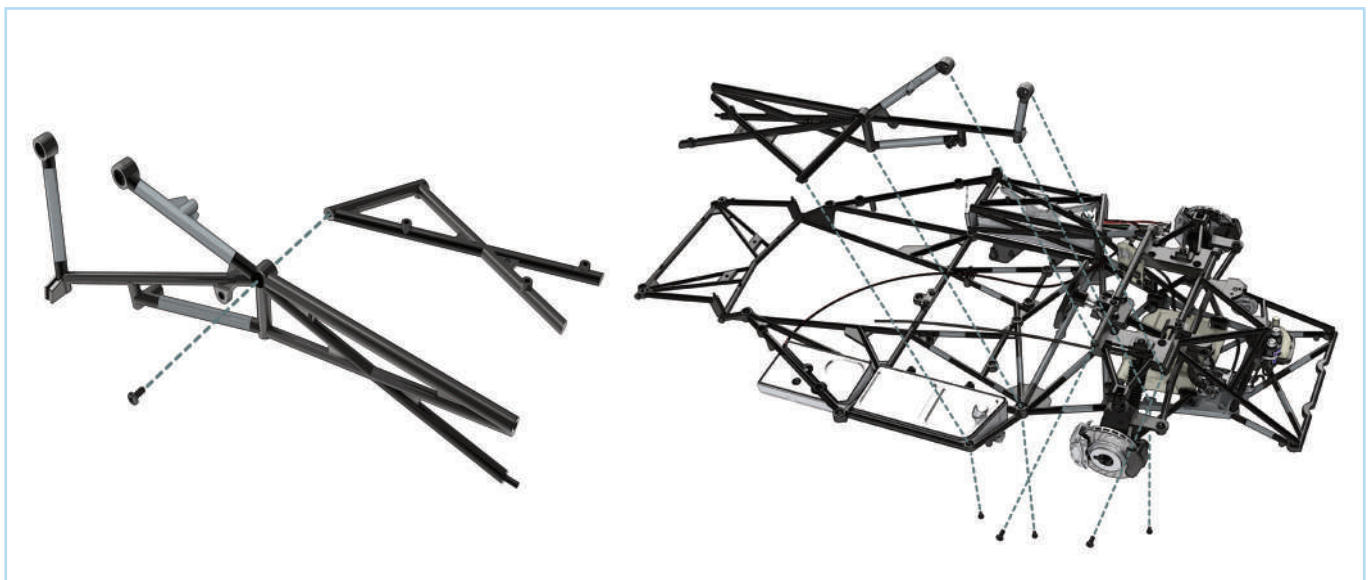

STAGE 34: ADDING THE RIGHT COCKPIT TUBULAR FRAME TO THE CHASSIS

STEP 1

Align the **tubular frames (34A and 34B)** with each other as shown and fit together. Secure using an **IM screw**.

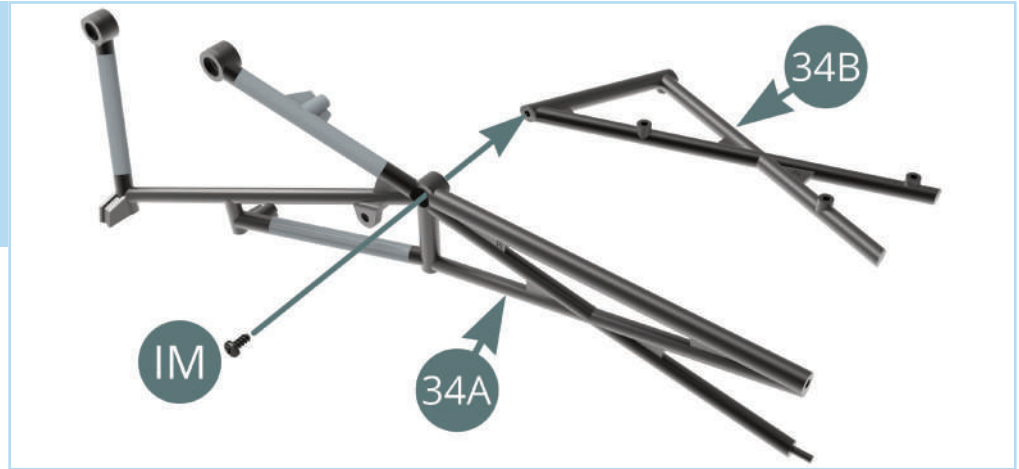

STEP 2

Align the tubular frame assembly with the chassis assembly as shown. Fit into the **dashboard frame (27A)** (red arrows) and the **chassis (25A)**. Check the diagram below for the five connection points circled in red.

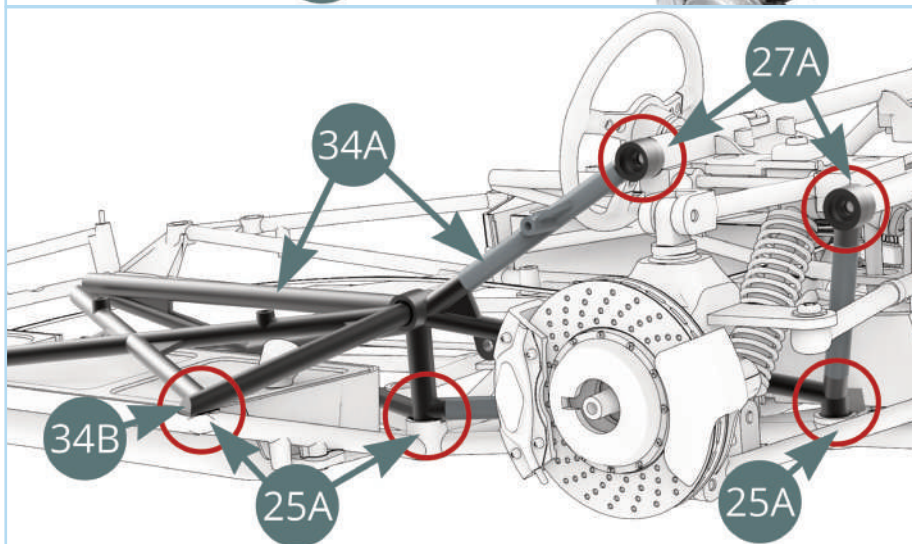
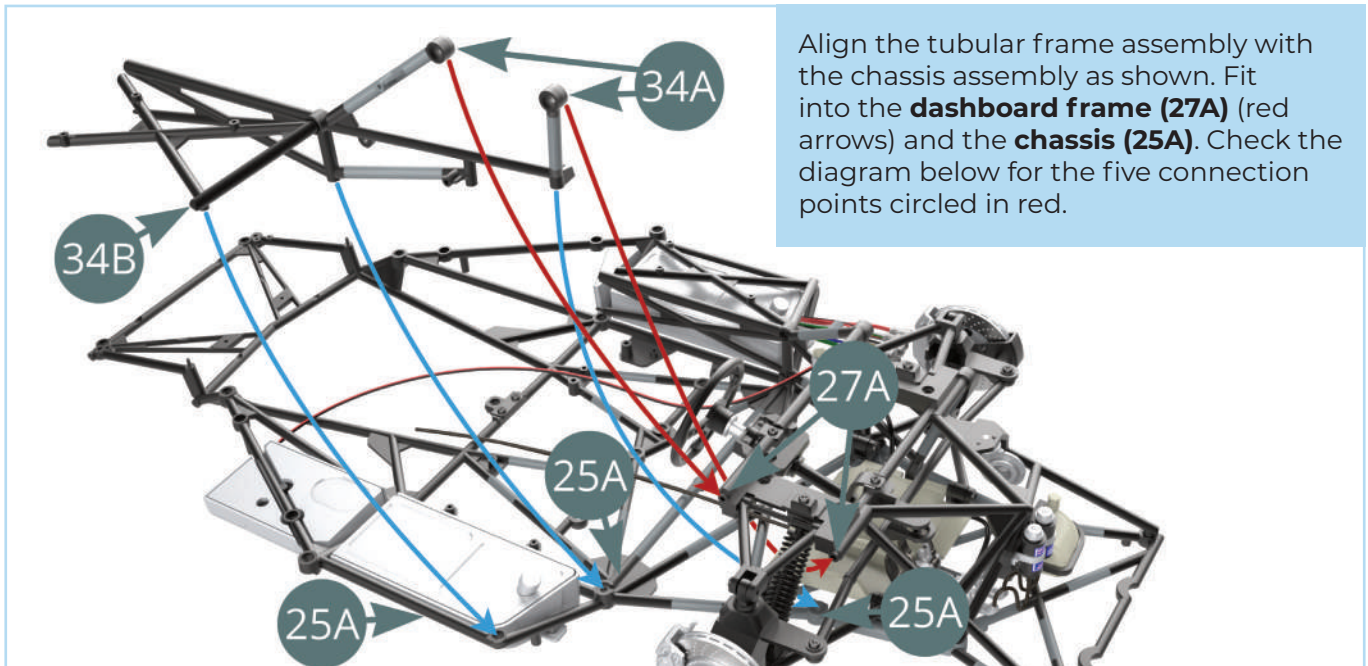

STAGE 34: ADDING THE RIGHT COCKPIT TUBULAR FRAME TO THE CHASSIS

STEP 3

To attach the tubular frame in place, start by driving two **BM** screws into the dashboard frame connection points as shown.

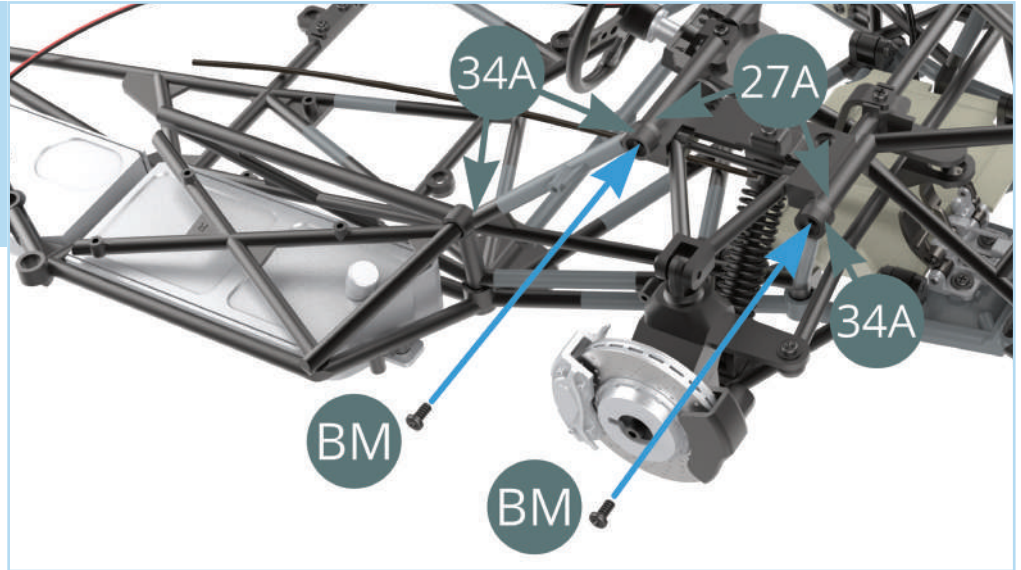

Turn the assembly over carefully and use two more **BM** screws to secure the connection points at the base of the chassis.

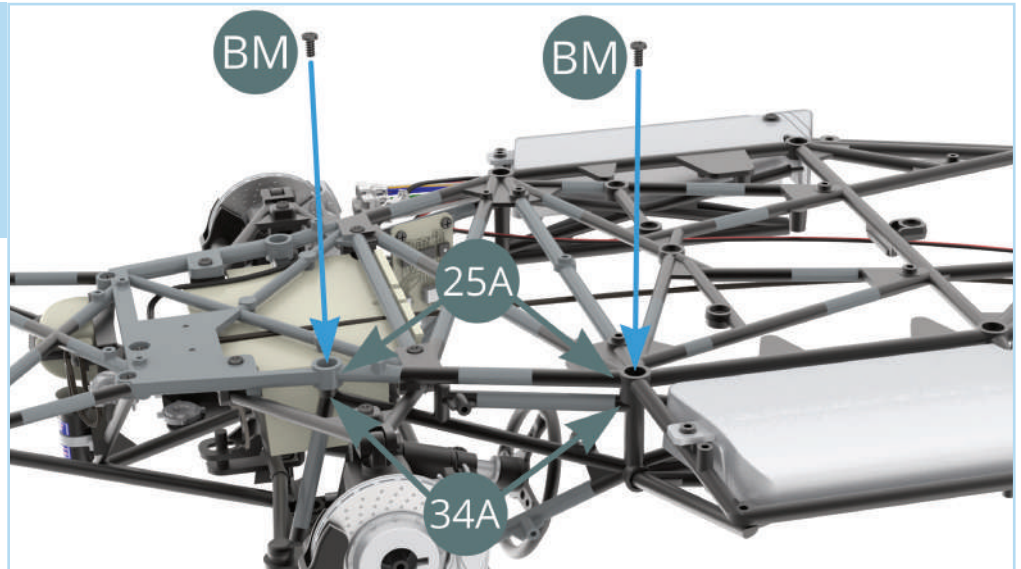

Use an **IM** screw to fix the connection point located next to the right tank.



STAGE 34: ADDING THE RIGHT COCKPIT TUBULAR FRAME TO THE CHASSIS

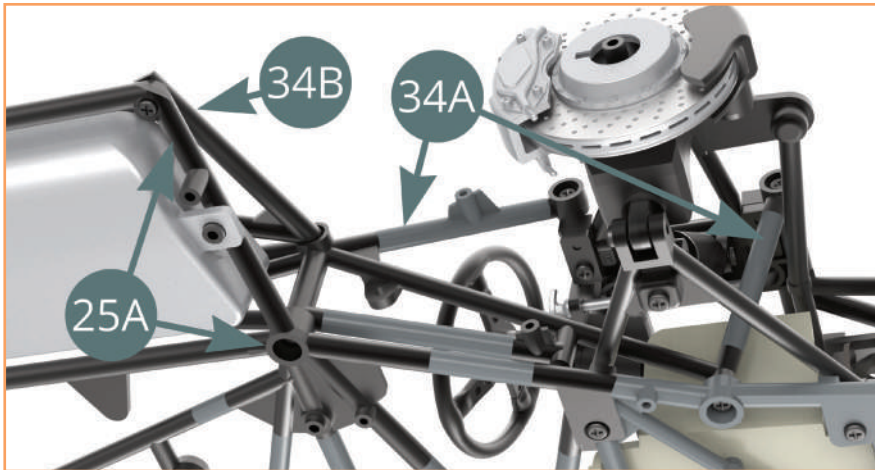

The tubular frame has been fixed to the chassis and dashboard frame.

STAGE COMPLETE

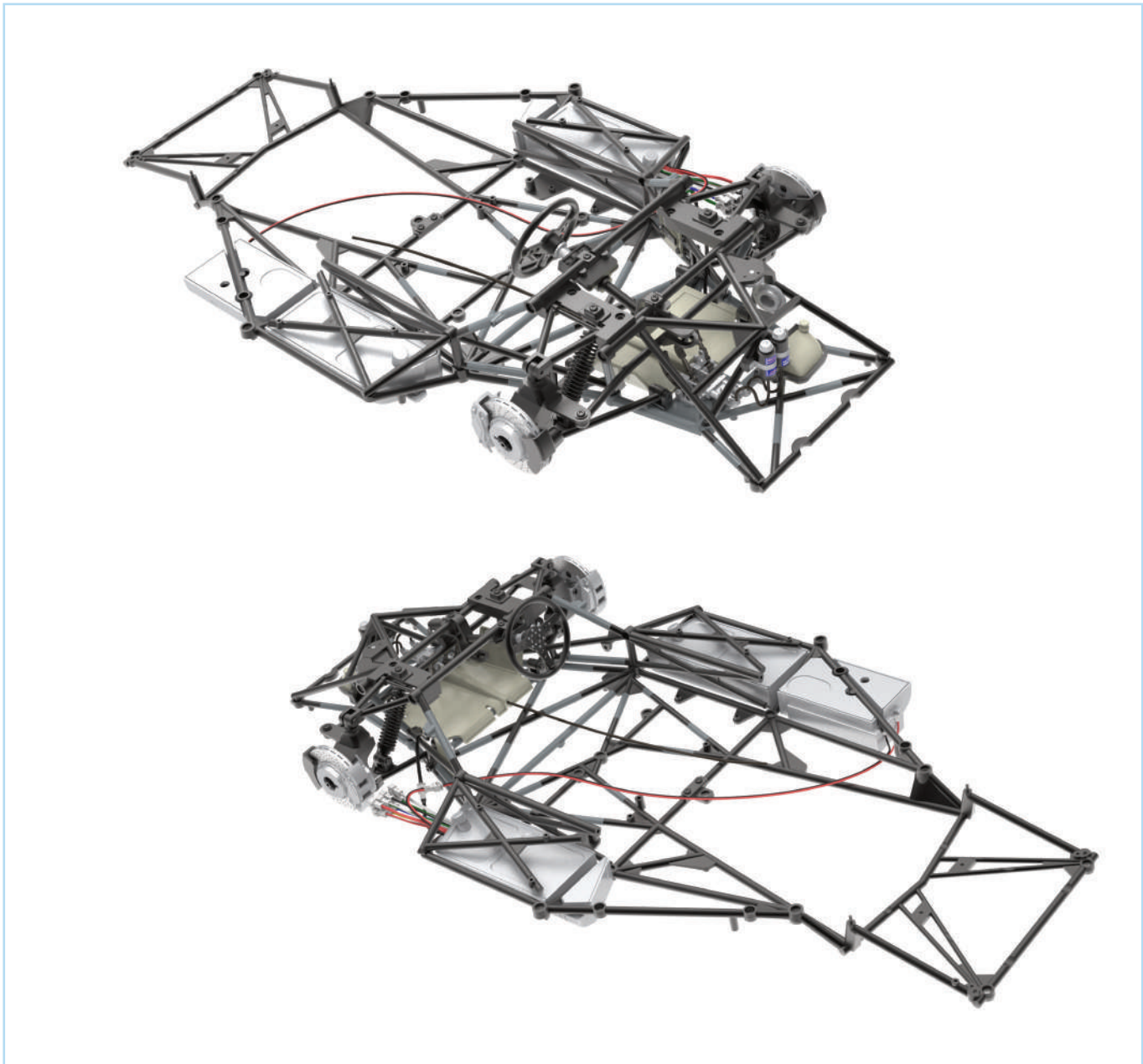

STAGE 35: FIXING THE MUDGUARDS AND ADDING THE ELECTRICAL CABLES

35A Left mudguard

35B Right mudguard

35C Washer

35D Left brake hose

35E Right brake hose

35F Headlight LED cable (white-green)

35G Tail lights LED cable (black-white)

35H Light switch cable (white)

35I Instrument backlight LED cable (red-white)

35J Adhesive tape strip (x6)

IM Screw 1.7 x 3.5 mm (x5)

MM Screw 2.0 x 4 x 5 mm (x2)

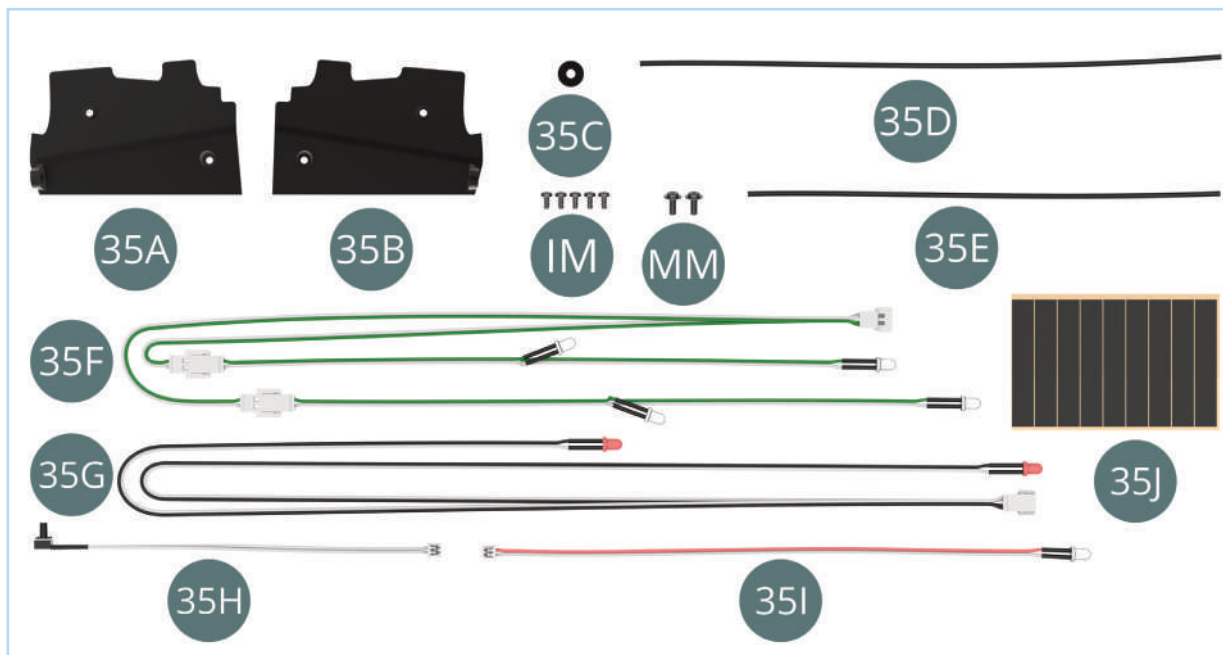

ASSEMBLY DIAGRAM

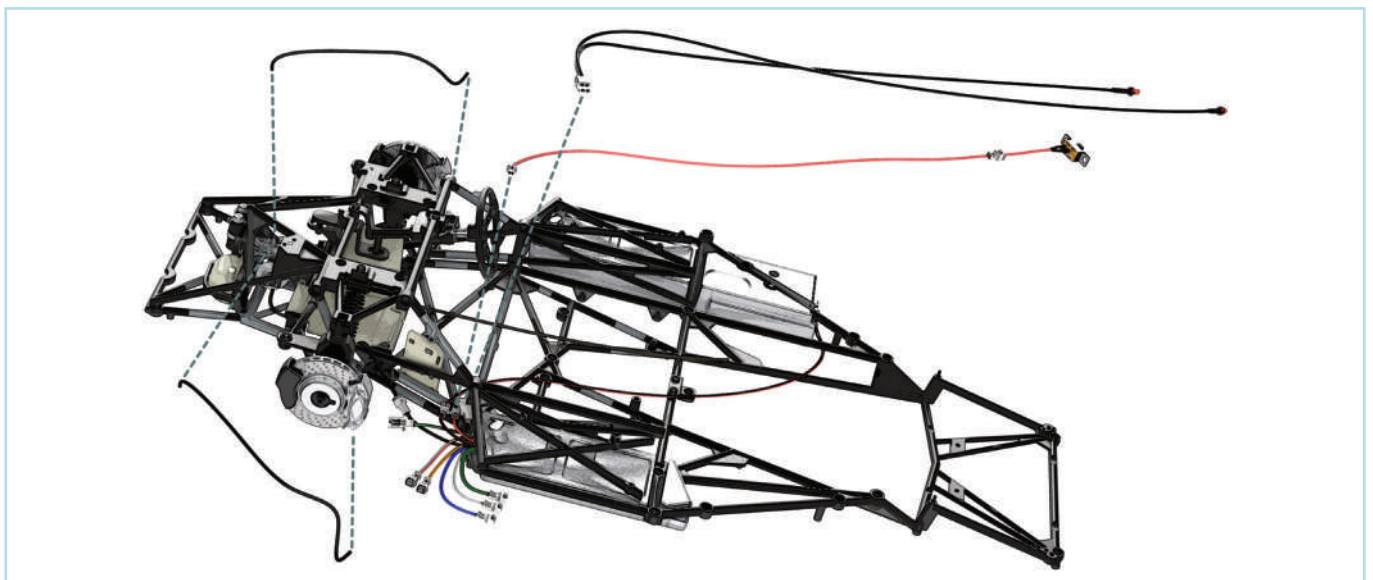

STAGE 35: FIXING THE MUDGUARDS AND ADDING THE ELECTRICAL CABLES

ASSEMBLY DIAGRAM

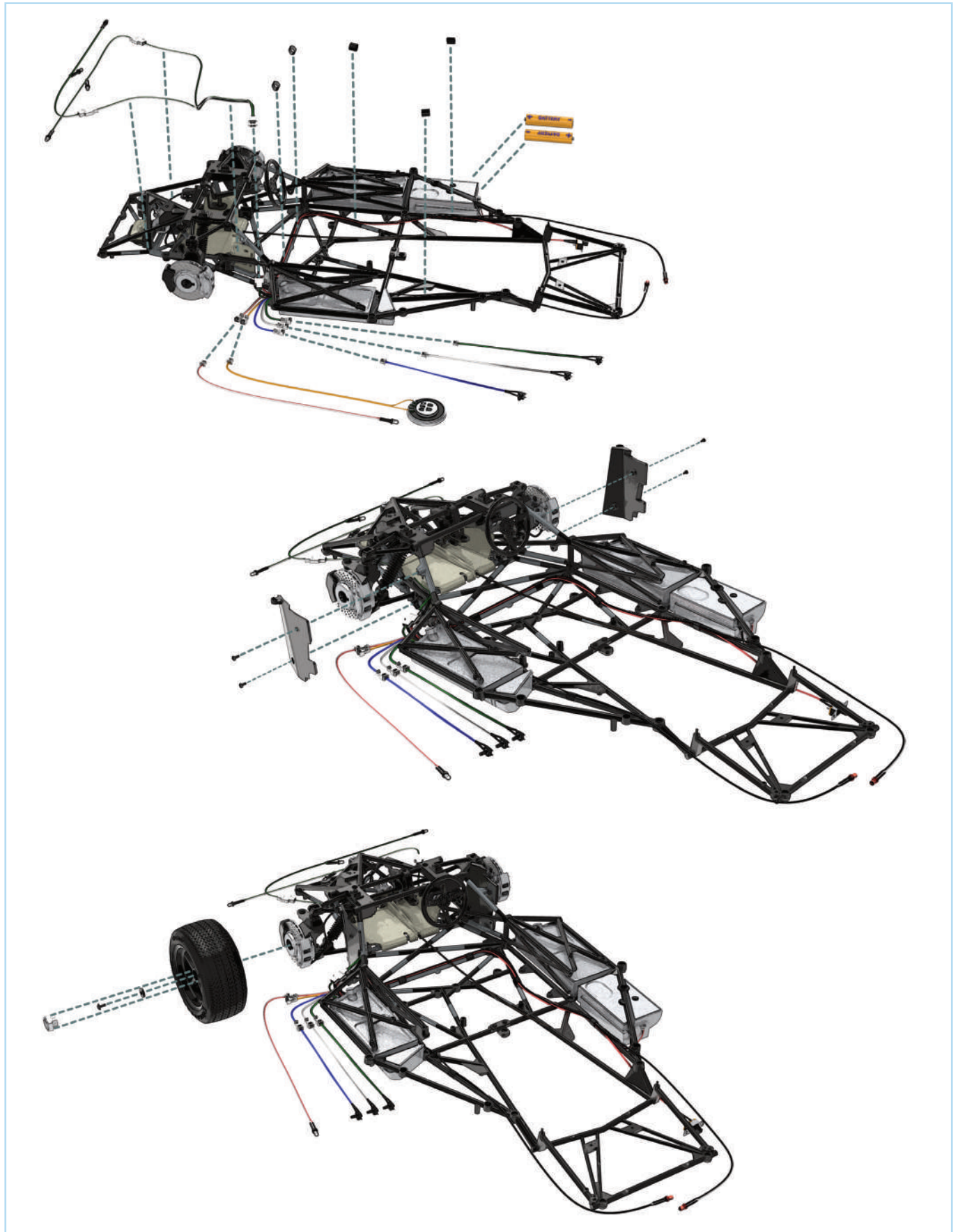

STAGE 35: FIXING THE MUDGUARDS AND ADDING THE ELECTRICAL CABLES

The left (35D) and right (35E) brake hoses will be installed for the first two steps of this stage. This image shows the hoses already installed – you can use this as a reference.

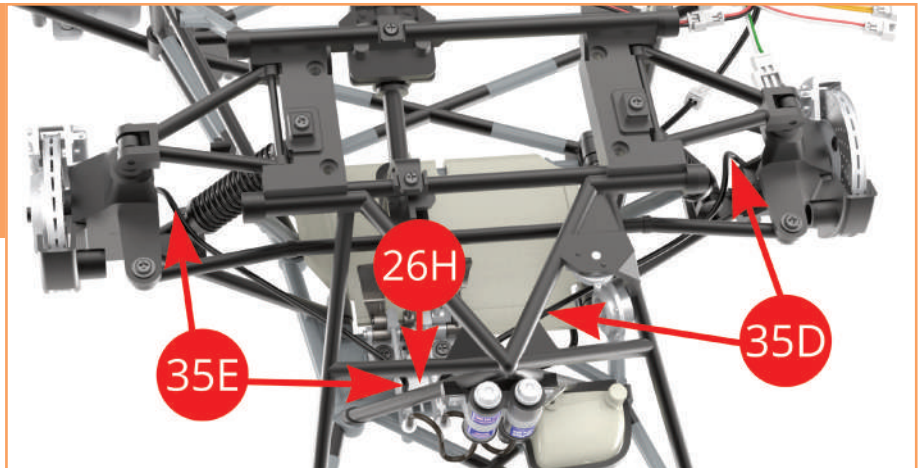

STEP 1

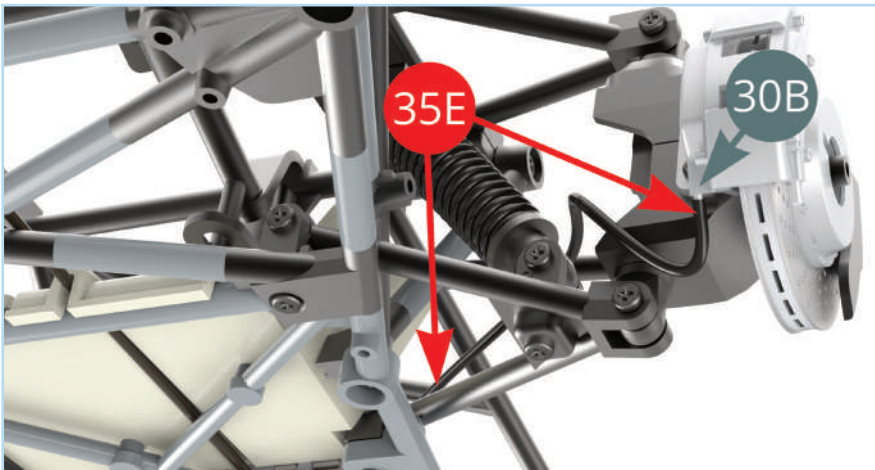

Take the shorter **right brake hose (35E)** and fit one end of it onto the small pin located under the right **brake piston cover (30B)**. Pass the other end around the shock absorber.

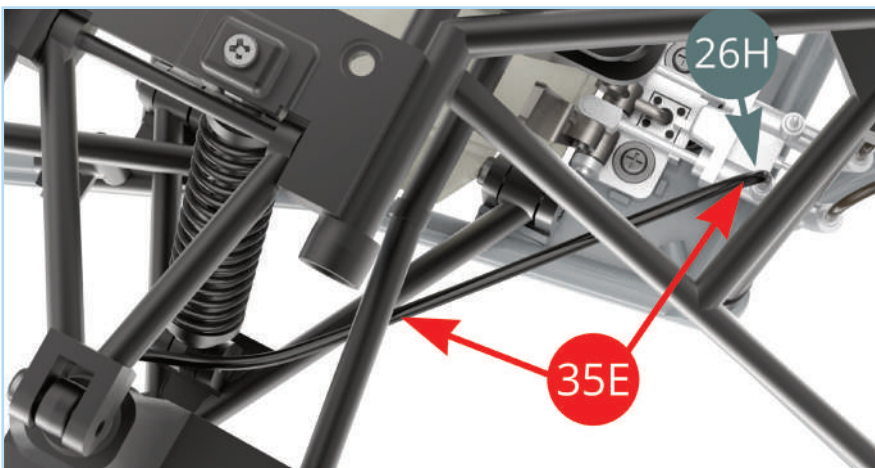

Guide the other end towards the **master cylinder (26H)** and attach it to the closest pin of the cylinder as shown.

STAGE 35: FIXING THE MUDGUARDS AND ADDING THE ELECTRICAL CABLES

STEP 2

Now fit one end of the **left brake hose (35D)** onto the small pin located under the **left brake piston cover (30B)**. Pass the other end around the shock absorber as shown.

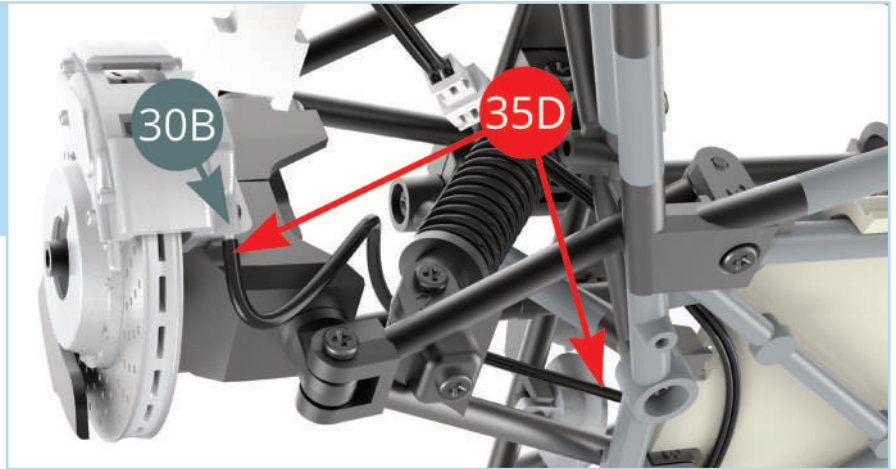

Guide the other end towards the **master cylinder (26H)** and attach it to the remaining pin of the cylinder as shown.

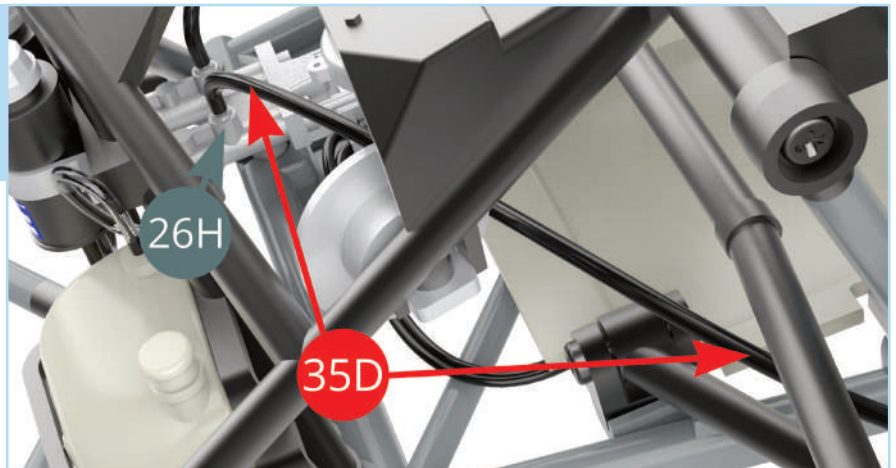

STEP 3

Moving to the left fuel tank, locate the black-white socket along with the red-red socket protruding from the circuit board (**32D**) inside the tank.

Retrieve the **switch cable (red-red) (33D)** supplied with Stage 33. Connect it to the corresponding red-red socket. Plug the **tail light LED cable (black-white) (35G)** into the black-white socket.

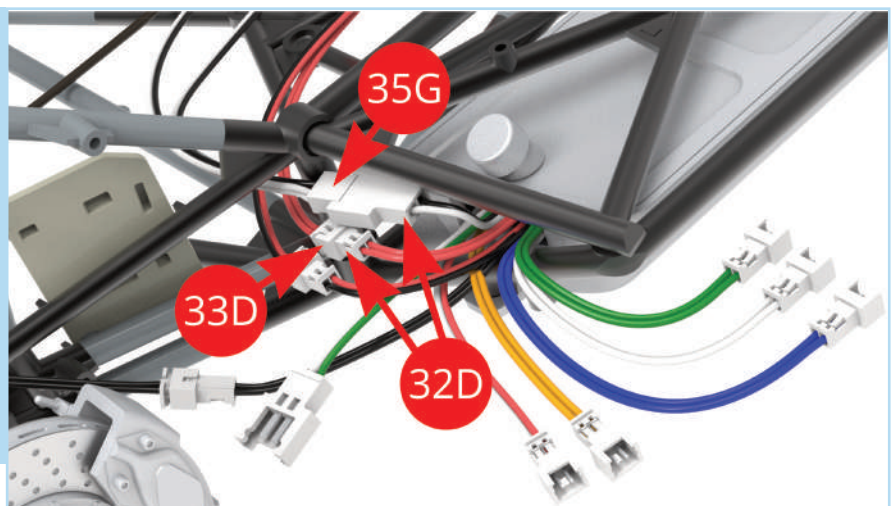

STAGE 35: FIXING THE MUDGUARDS AND ADDING THE ELECTRICAL CABLES

Pull the bulb end of each cable towards the rear of the chassis as shown. Identify the longest (blue arrow) and shortest (green arrow) of the two **tail light LED cables (black-white) (35G)**.

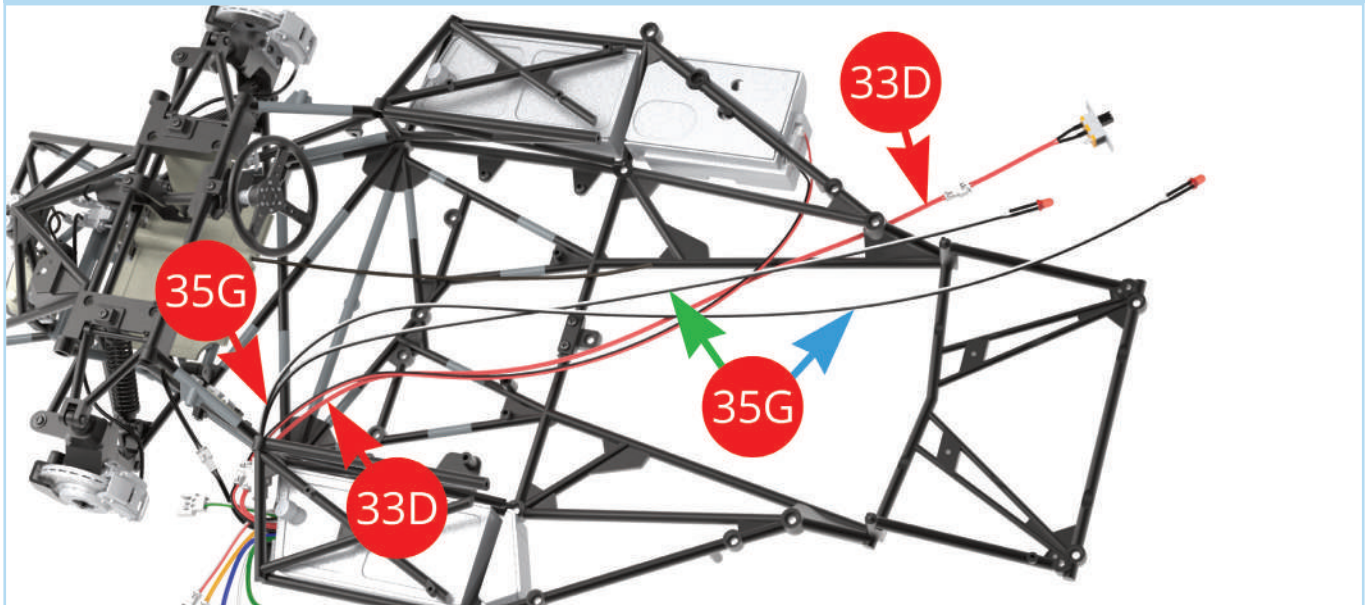

STEP 4

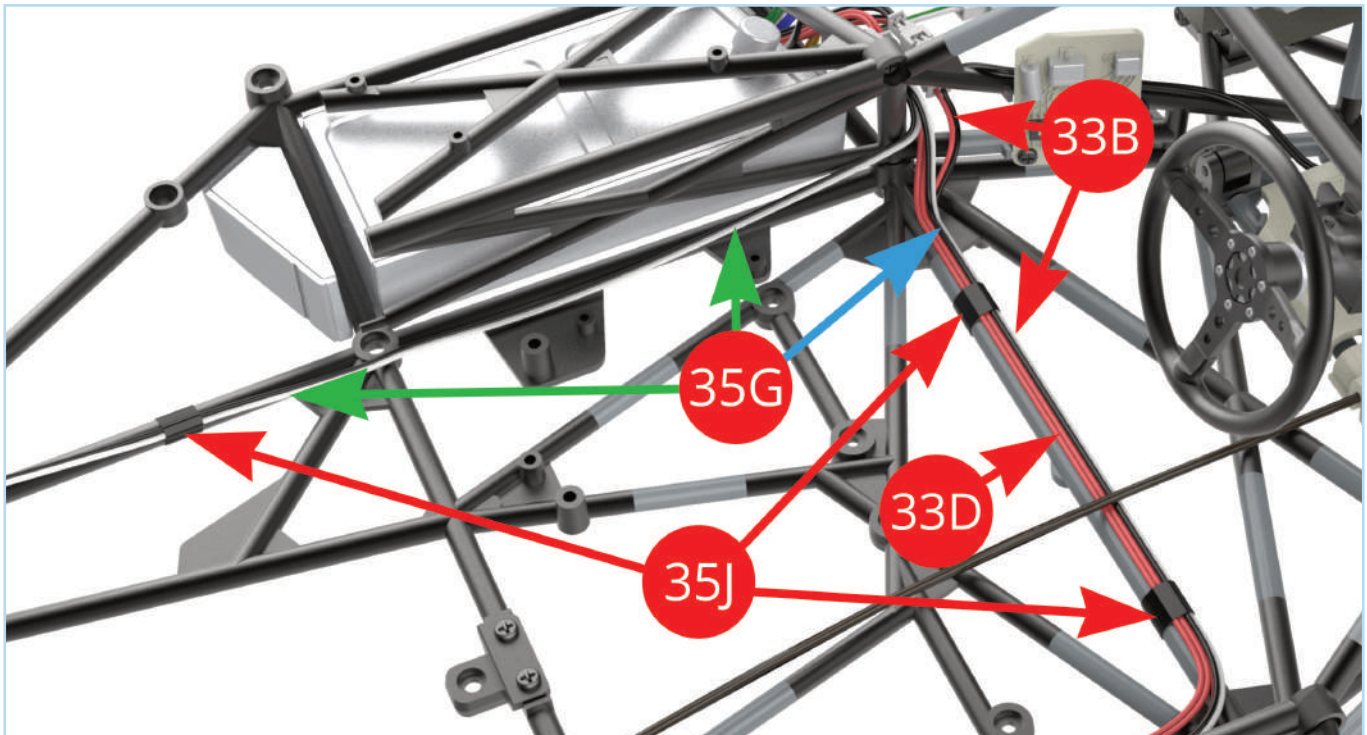

Guide the **right fuel tank cable (black-red) (33B)**, the **switch cable (red-red) (33D)** and the longer (blue arrow) **tail light LED cable (black-white) (35G)** along the right side of the chassis, then tape them together on the tube with two pieces of **adhesive tape (35J)**.

Run the shorter (green arrow) **tail light LED cable (black-white) (35G)** along the left side of the chassis and tape it to the tube with one piece of **adhesive tape (35J)**.

STAGE 35: FIXING THE MUDGUARDS AND ADDING THE ELECTRICAL CABLES

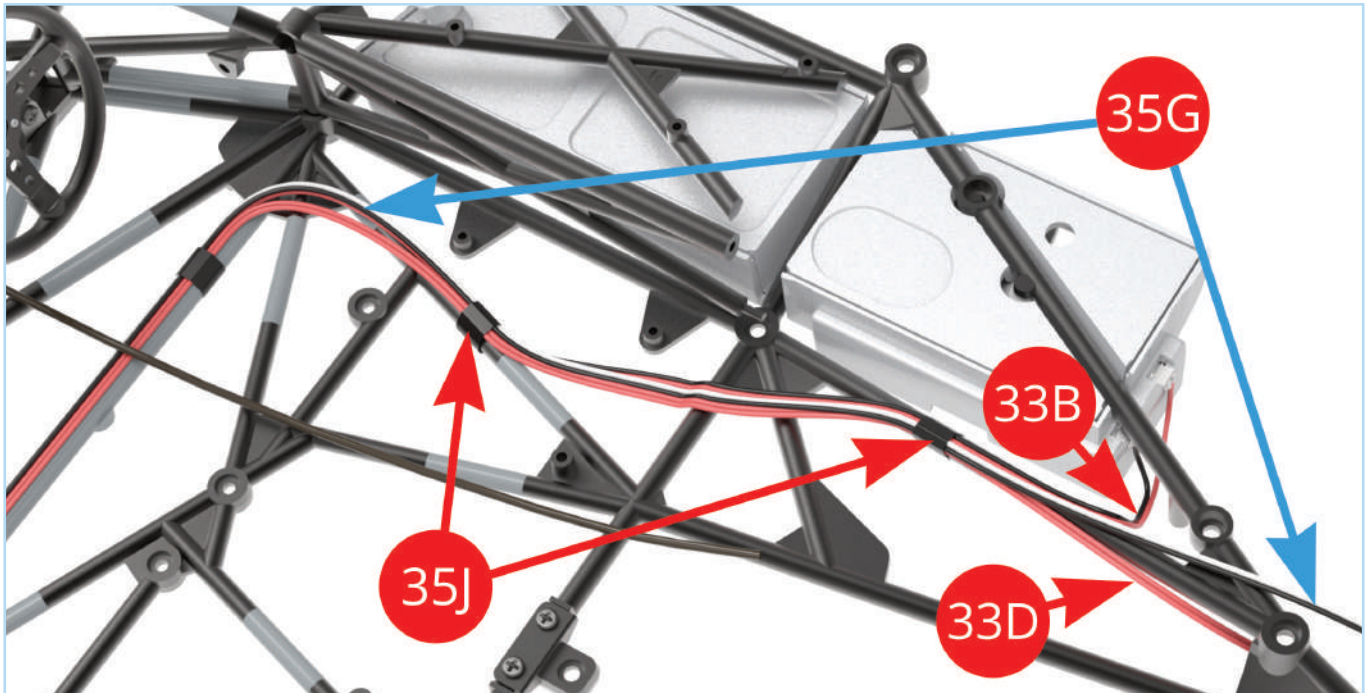

Attach the bundled **right fuel tank cable (black-red) (33B)**, **switch cable (red-red) (33D)** and longer (blue arrow) **tail light LED cable (black-white) (35G)** to the right side of the chassis with two more pieces of **adhesive tape (35J)**.

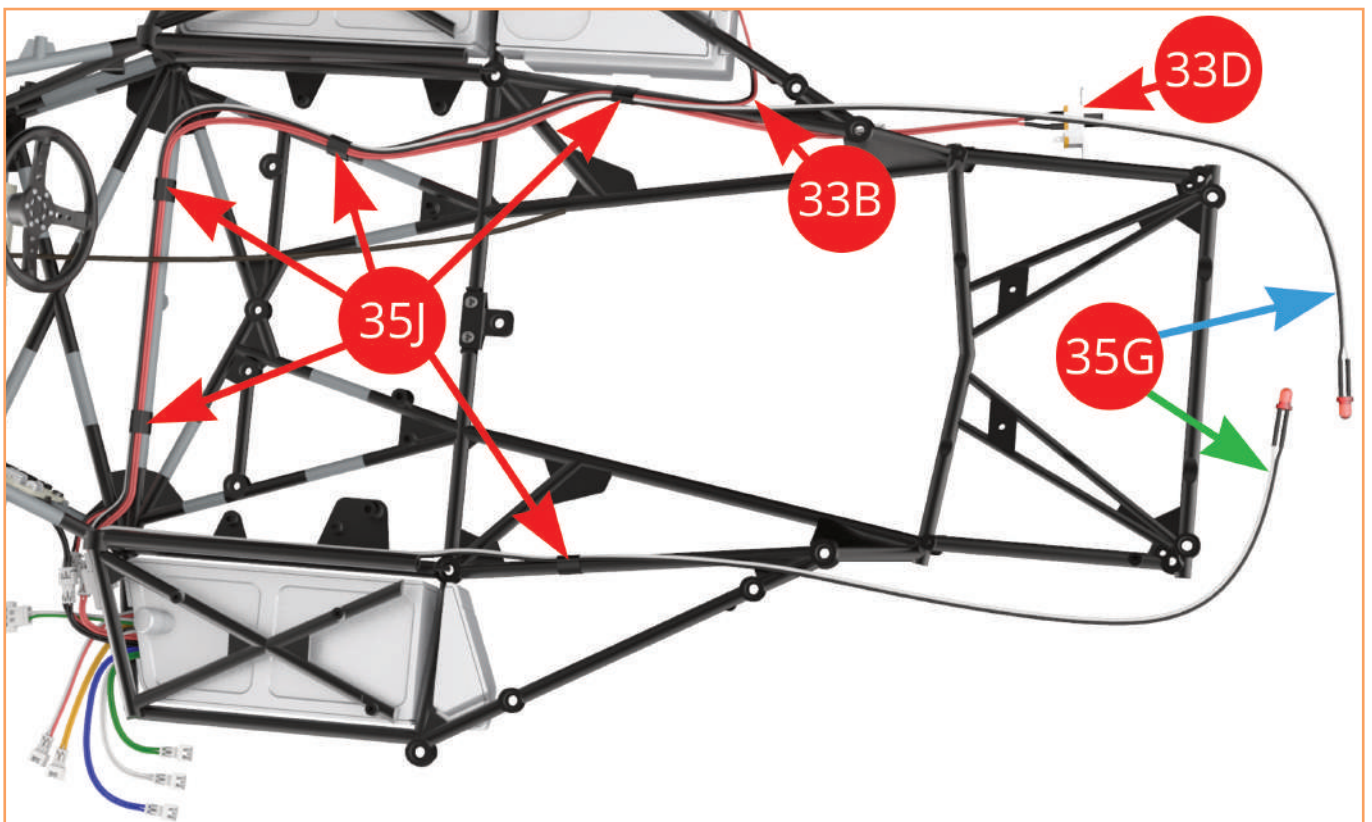

The **right fuel tank cable (black-red) (33B)**, the **switch cable (red-red) (33D)** and the **tail light LED cable (black-white) (35G)** should look like this once they have been installed on the chassis.

STAGE 35: FIXING THE MUDGUARDS AND ADDING THE ELECTRICAL CABLES

STEP 5

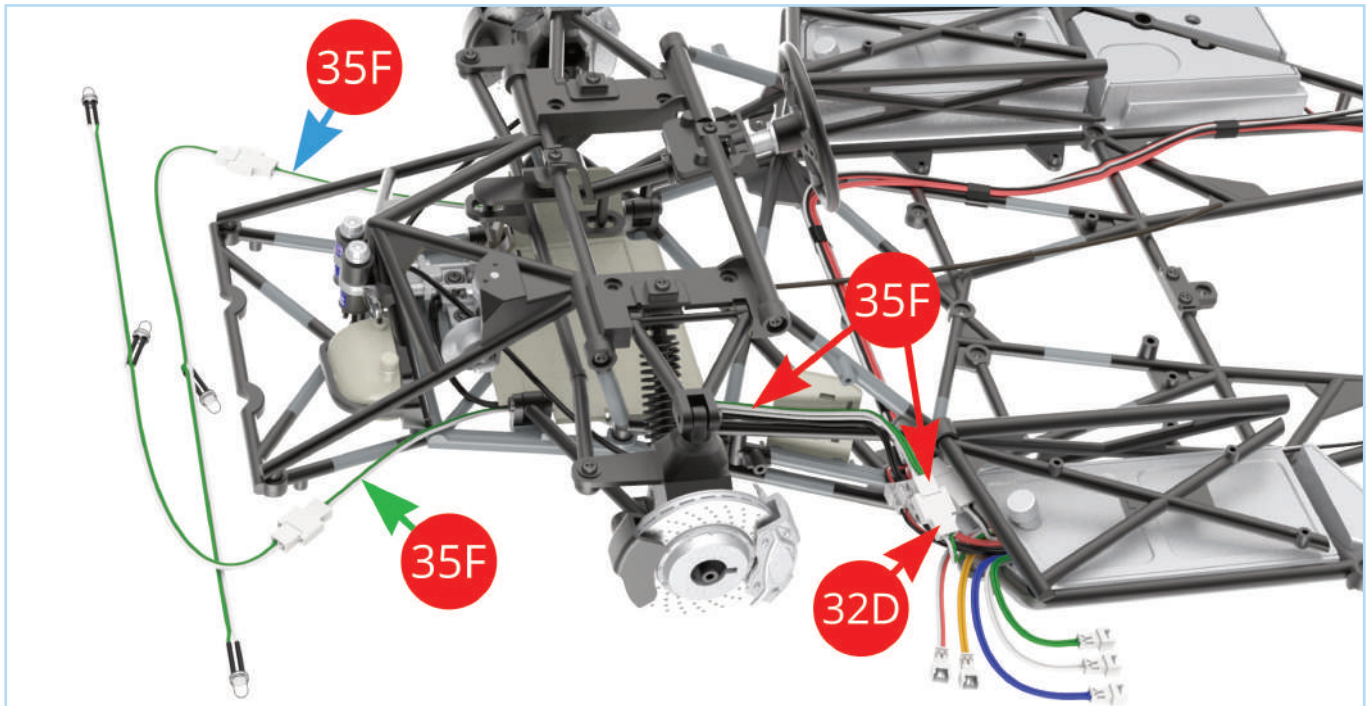

Connect the **headlight LED cable (white-green) (35F)** into the socket of the same colour from the **circuit board (32D)**. Identify the longest (blue arrow) and shortest (green arrow) of the headlight LED cables (**35F**). Weave the two cables through the chassis towards the front using the images above and below as a guide.

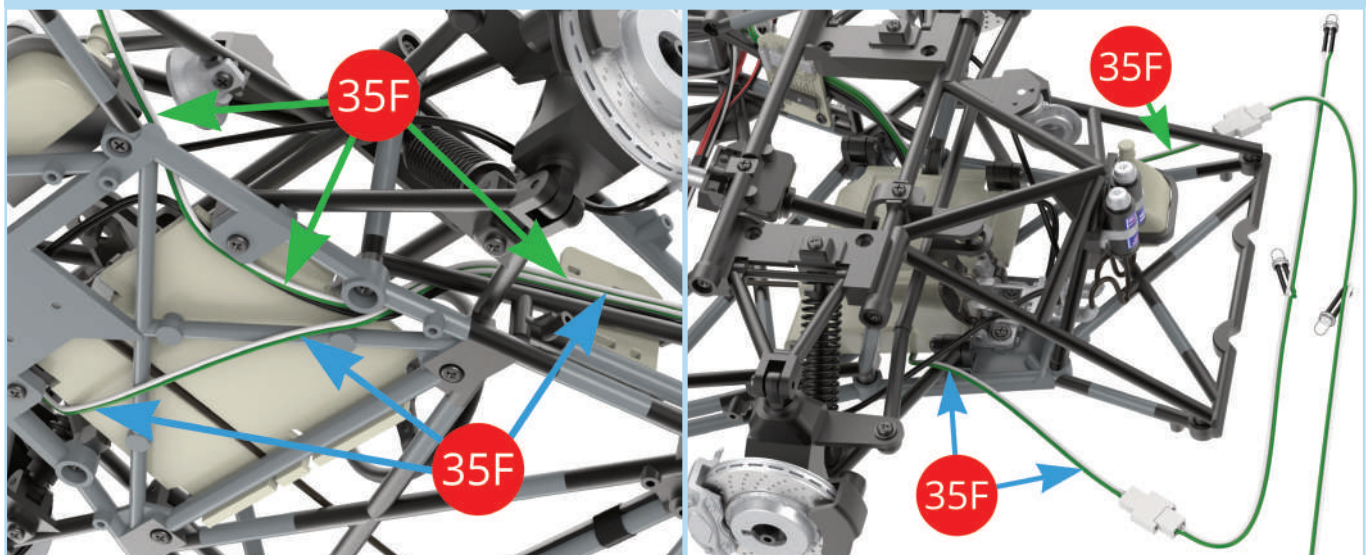

STAGE 35: FIXING THE MUDGUARDS AND ADDING THE ELECTRICAL CABLES

STEP 6

Connect the **horn switch cable (green) (34E)**, the **light switch cable (white) (35H)**, the **engine sound switch cable (blue) (34D)**, the **speaker cable (yellow) (34C)** and the **instrument backlight LED cable (red-white) (35I)** to the same coloured sockets on the **circuit board (32D)**.

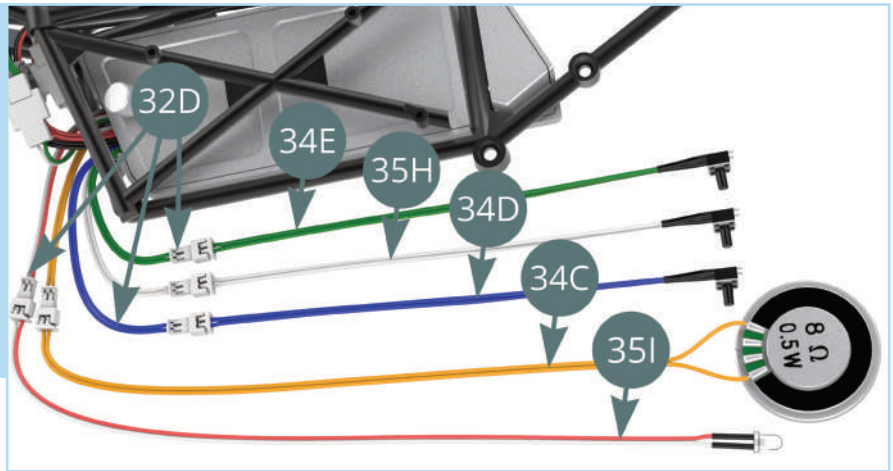

Place two AAA batteries (not supplied) into the battery compartment inside the **right fuel tank (33B)** (red arrows).

To test the electrics, turn the **switch (33D)** to the 'ON' position (blue arrow).

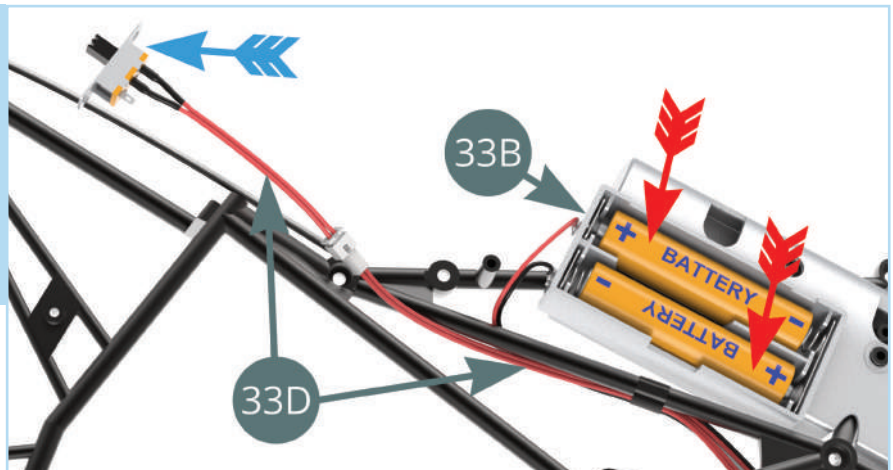

STEP 7

Press the **horn switch (green) (34E)** – you should hear the sound of the horn through the **speaker (34C)**.

Press the **engine sound switch (blue) (34D)** – you should hear the sound of the engine through the **speaker (34C)**.

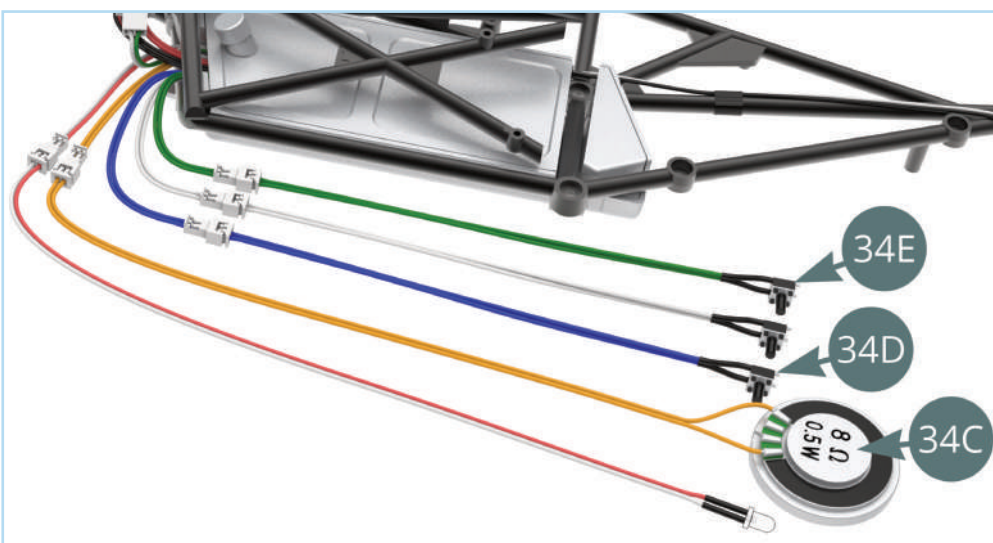

STAGE 35: FIXING THE MUDGUARDS AND ADDING THE ELECTRICAL CABLES

STEP 8

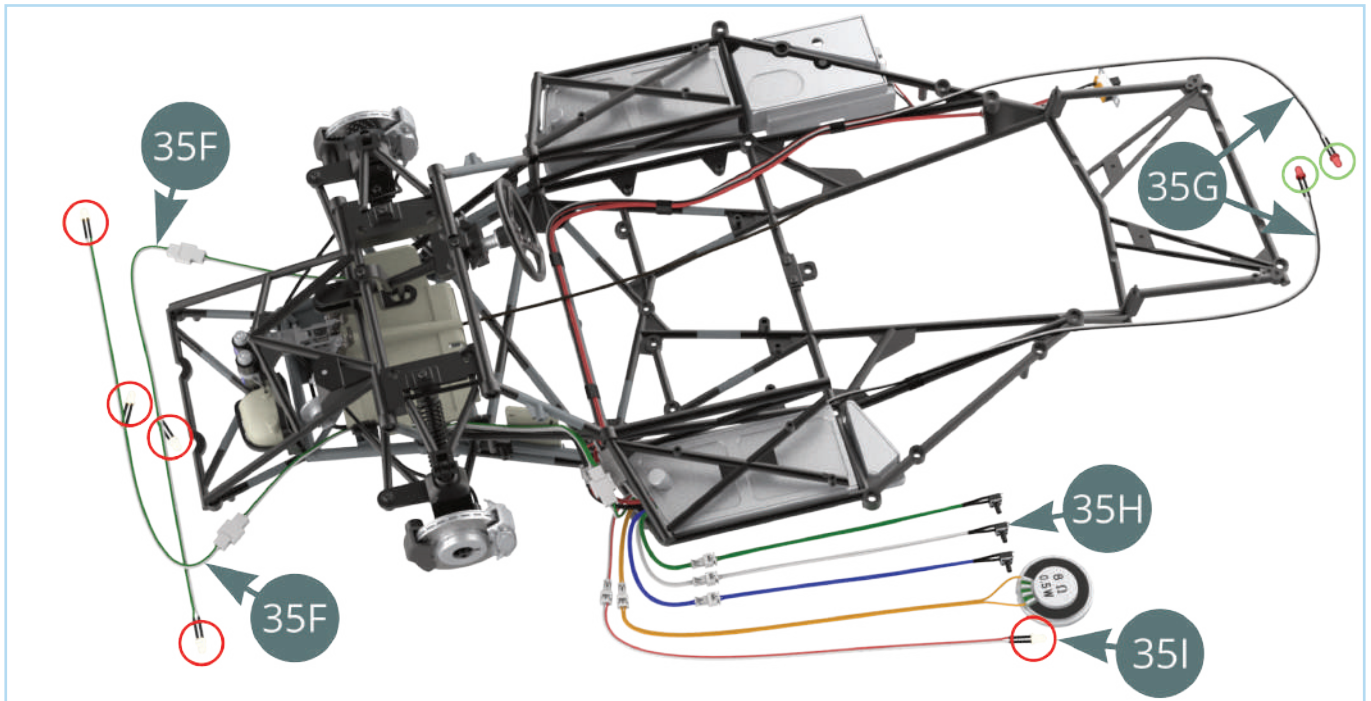

Reduce the ambient light to make it easier to test the light bulbs. Press the **light switch (35H)** – the **headlights (35F)** and **instrument panel backlight (35I)** should illuminate in white (red circles). The **tail lights (35G)** should illuminate in red (green circles).

STEP 9

Press the **middle pedal (26F)** – the **tail lights (35G)** should illuminate in red while the pedal is pressed.

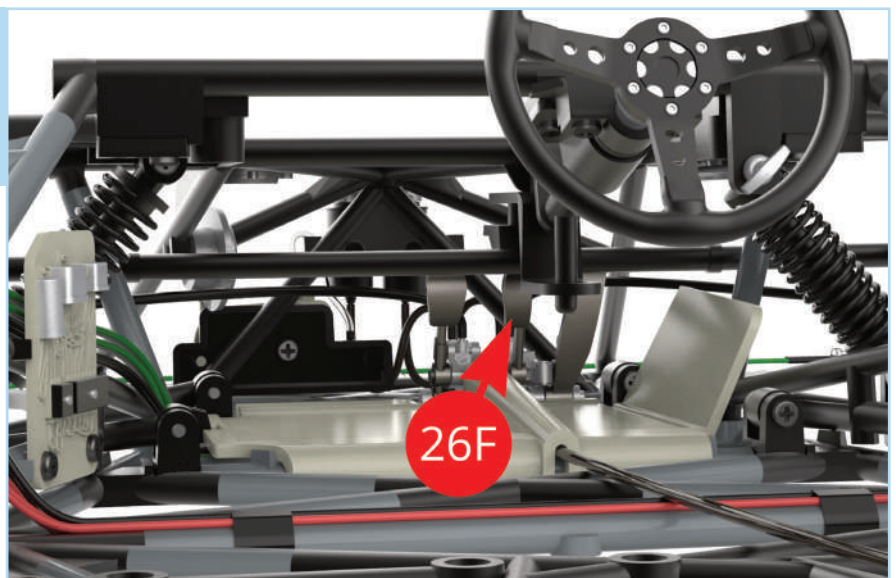

After having tested the operation of all lights and sounds, turn the **switch (33D)** to the 'OFF' position. If any of the electrics do not work as intended, carefully check the connection of the cable to the socket on the circuit board.

STAGE 35: FIXING THE MUDGUARDS AND ADDING THE ELECTRICAL CABLES

STEP 10

Disconnect the **speaker (34C)** from the yellow **circuit board (32D)** cable (red arrows) to avoid damaging it during the rest of the assembly of your model. Store it safely away until it is needed.

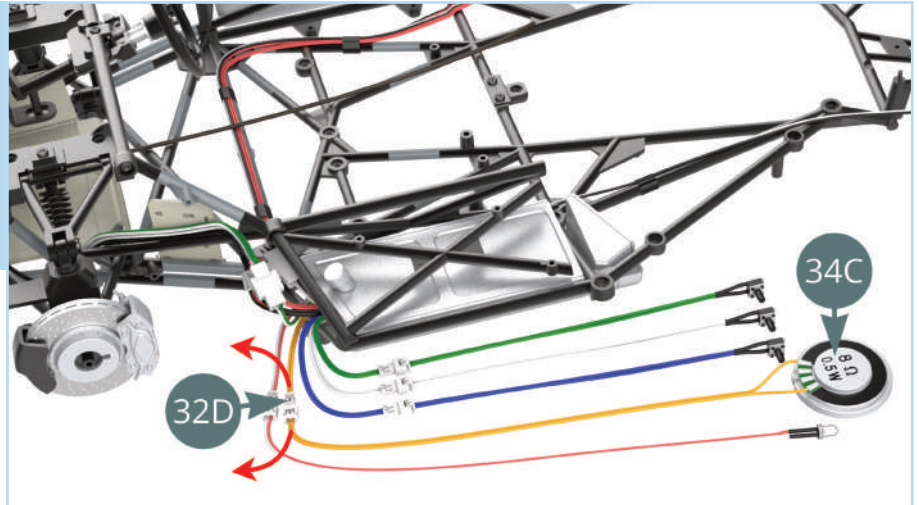

STEP 11

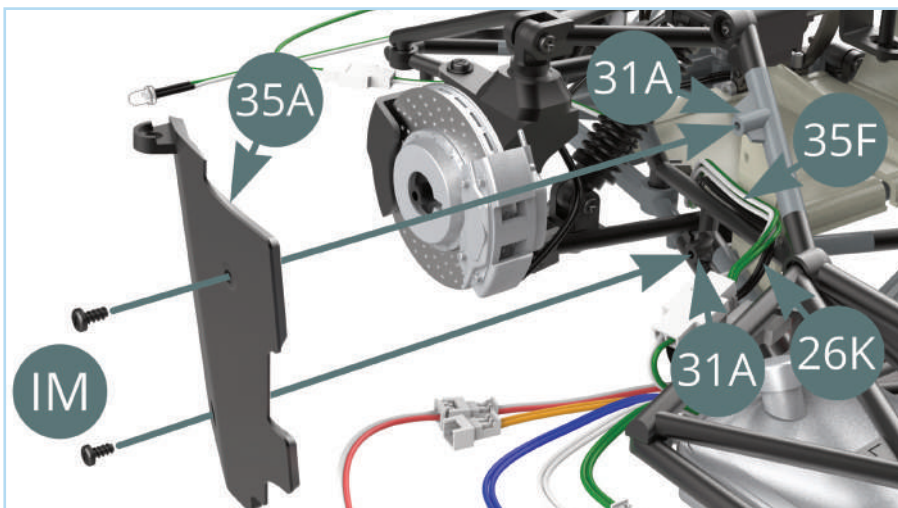

Position the **left mudguard (35A)** onto the **tubular frame (31A)**. Hide the cables (**26K** and **35F**) behind the mudguard while fitting in place (see bottom image). Secure the mudguard in place using two **IM** screws.

Take care not to damage the pins of the brake piston cover while driving the bottom screw in.

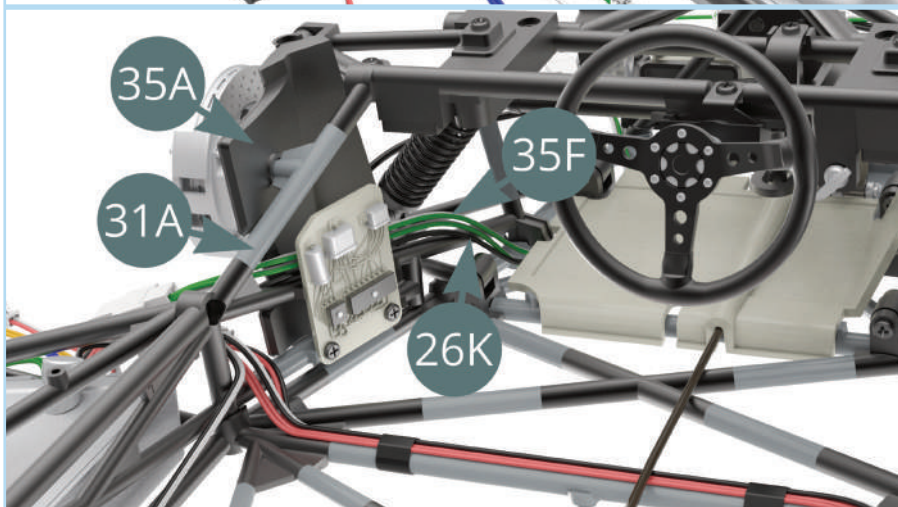

STAGE 35: FIXING THE MUDGUARDS AND ADDING THE ELECTRICAL CABLES

STEP 12

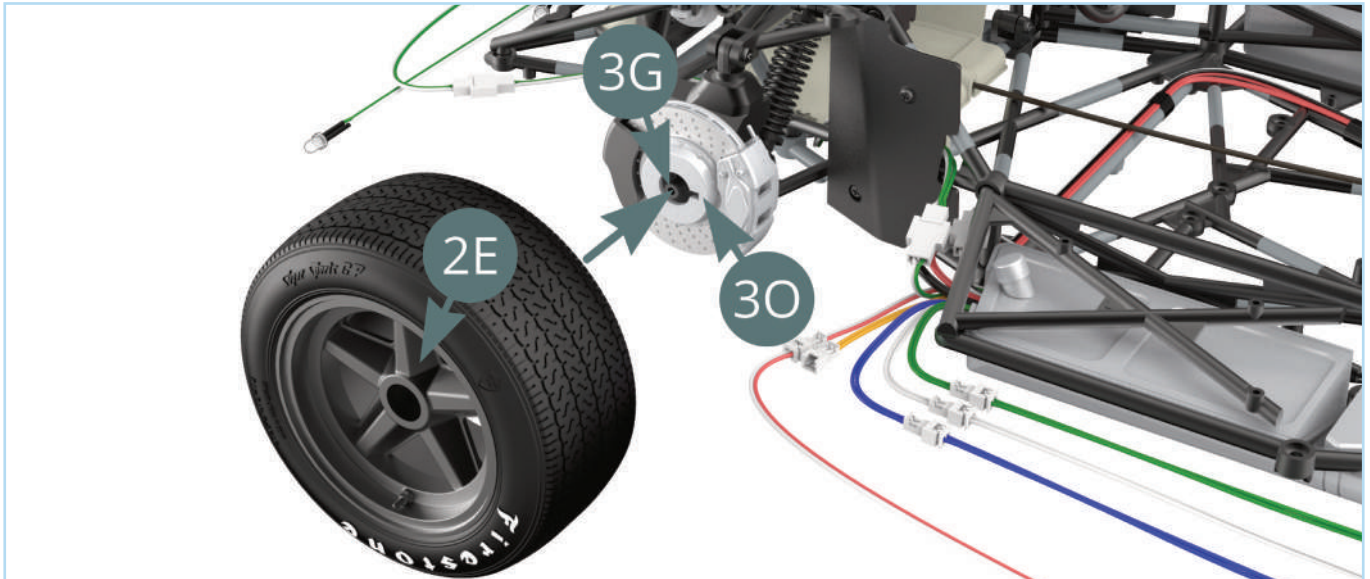

Take the front wheel assembled in stage 2 and fit the **wheel rim (2E)** on the **hub carrier (3G)**. Turn it until the rim engages with the notch on the **outer brake disc (30)**.

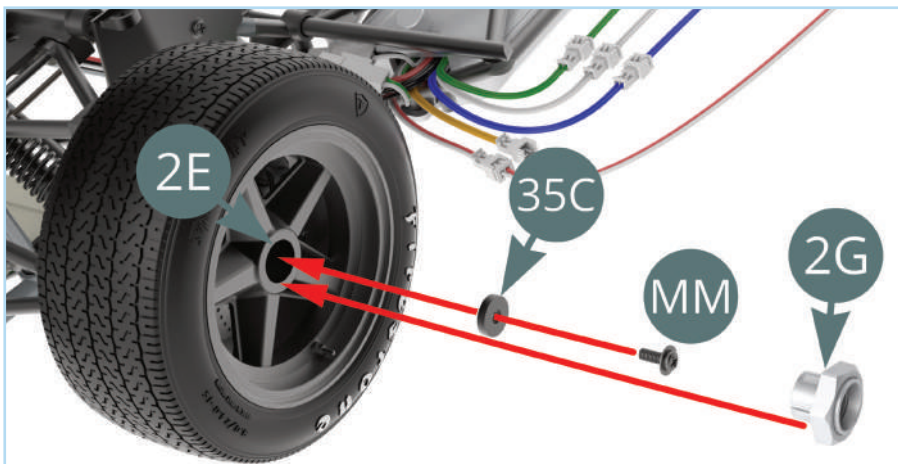

Push an **MM** screw through the **washer (35C)** then use it to attach the wheel. Take the **hub cap (2G)** from stage 2 and position it on the **outer rim (2E)**.

Check that the brake disc and wheel spin in unison.

STEP 13

Fit the **right mudguard (35B)** on the tubular frame and fix it in place using two **IM** screws.

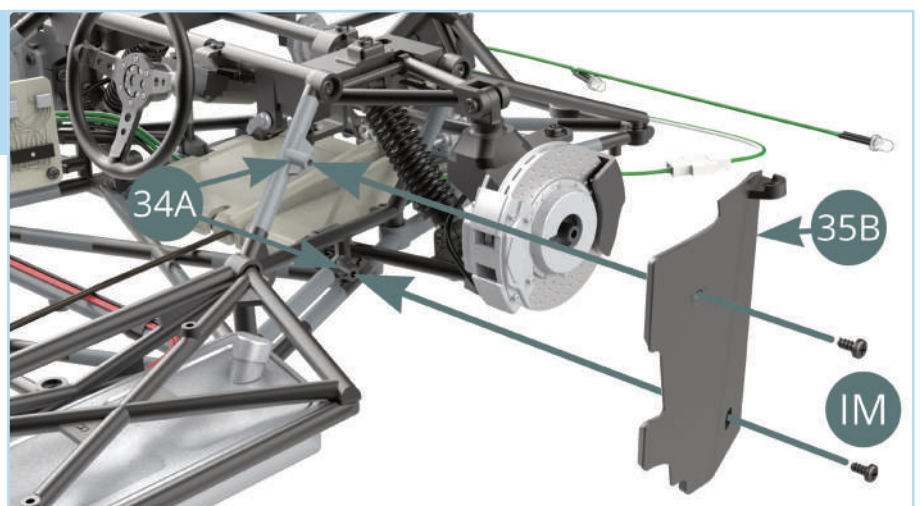

STAGE 35: FIXING THE MUDGUARDS AND ADDING THE ELECTRICAL CABLES

STAGE COMPLETE

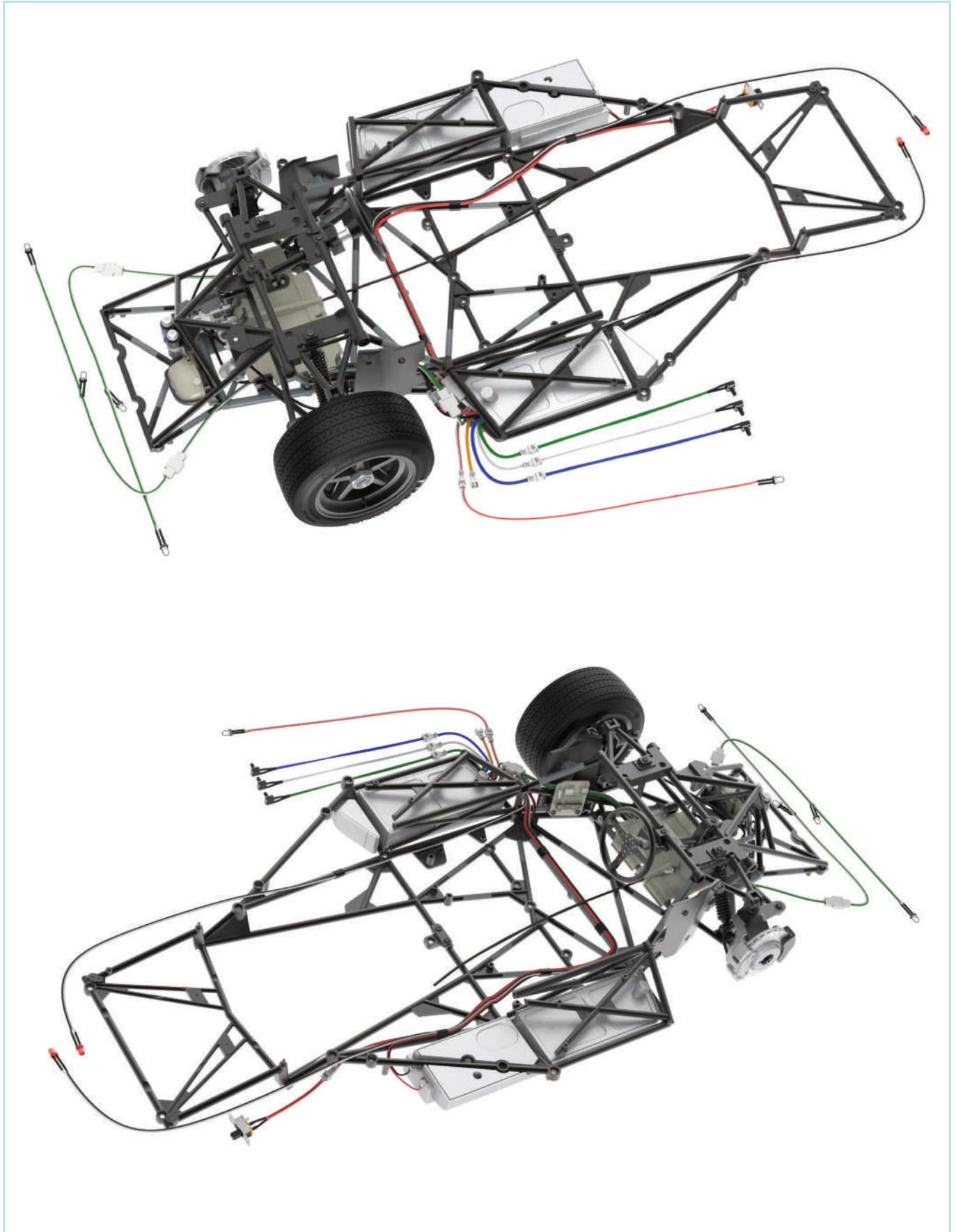

STAGE 36: ASSEMBLING AND ATTACHING THE RIGHT FRONT WHEEL

36A Front tyre

36B Front wheel outer rim

36C Front wheel inner rim

36D Hub cap

36E Washer

MM Screw 2.0 x 4 x 5 mm (x2)

BM Screw 2.0 x 4 mm (x4)



ASSEMBLY DIAGRAM

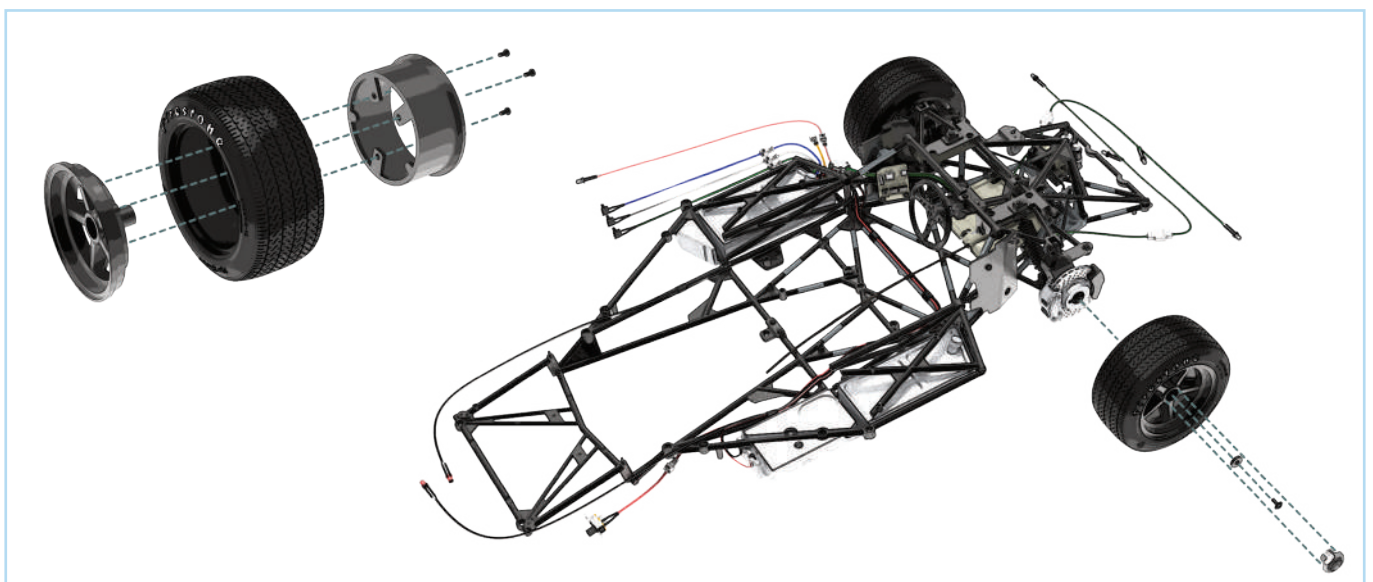

STAGE 36: ASSEMBLING AND ATTACHING THE RIGHT FRONT WHEEL

STEP 1

Fit the **front wheel outer rim (36B)** into the **front tyre (36A)**.



Press the **front wheel inner rim (36C)** into the **front tyre (36A)**, making sure to align the screw holes with the **outer rim (36B)**. Drive in three **BM** screws to fix the parts together.

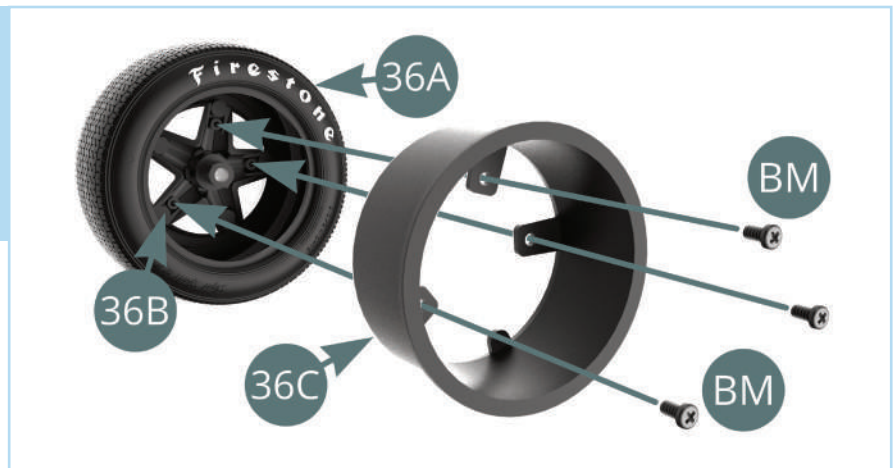

STEP 2

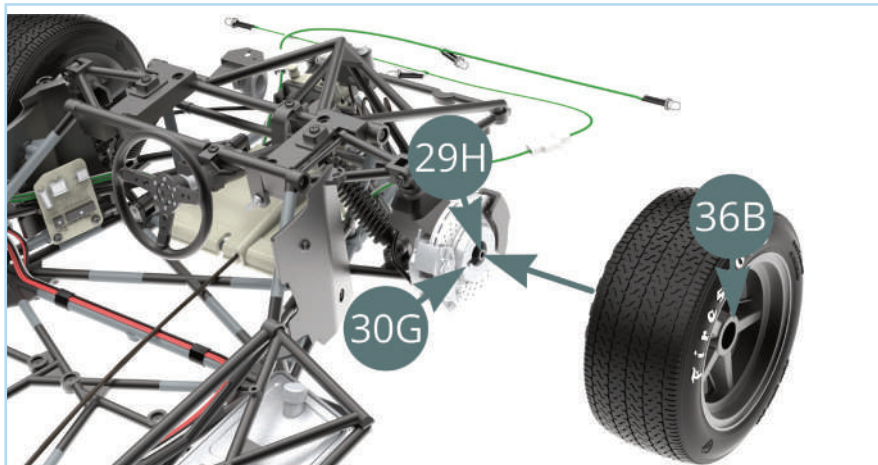

Now position the wheel on the axle of the **hub carrier (29H)** and turn until it engages with the notch in the **outer brake disc (30G)**.

STAGE 36: ASSEMBLING AND ATTACHING THE RIGHT FRONT WHEEL

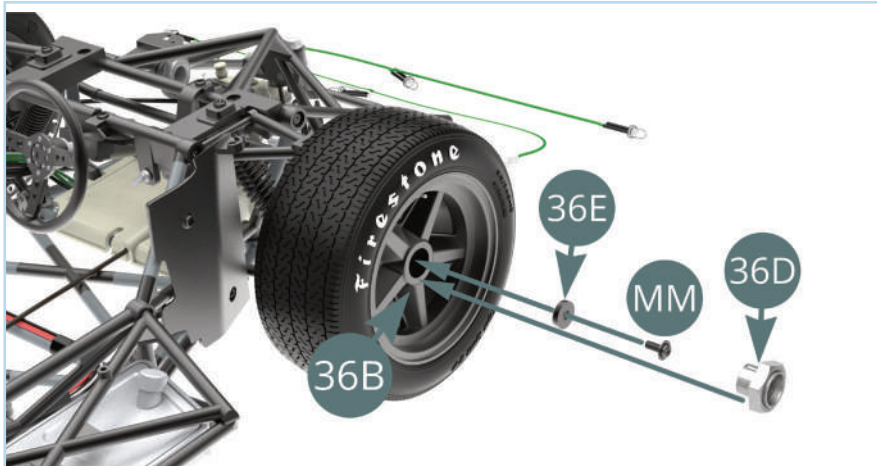

Push an **MM** screw through the **washer (36E)** and use it to attach the wheel, then take the **hub cap (36D)** and position it on the **outer rim (36B)**.

Check that the brake disc and wheel spin in unison.

STAGE COMPLETE

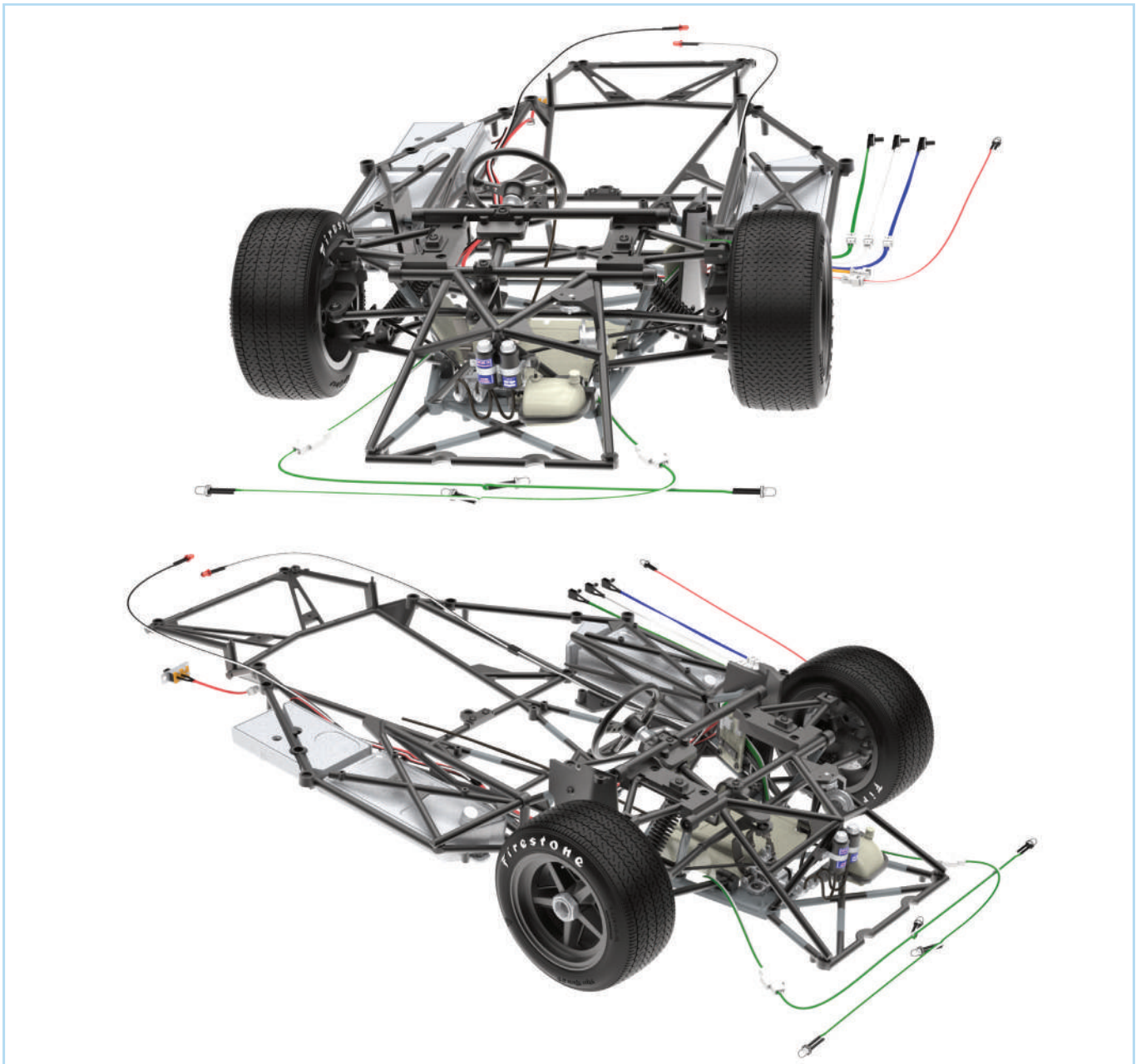

STAGE 37: FITTING THE COCKPIT PARTITION FRAME AND THE OIL HOSES

37A Cockpit partition frame

BM Screw 2.0 x 4 mm (x5)

37B Water hose (x2)

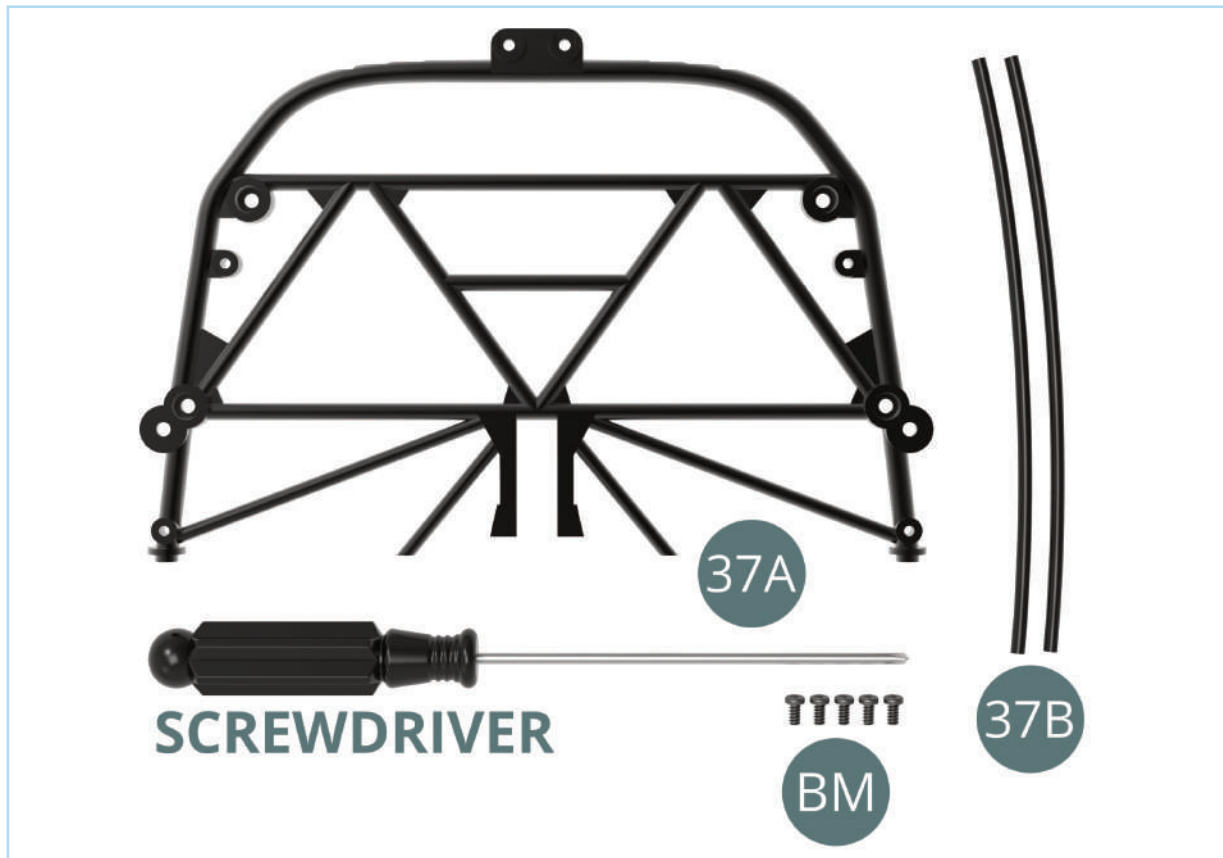

ASSEMBLY DIAGRAM

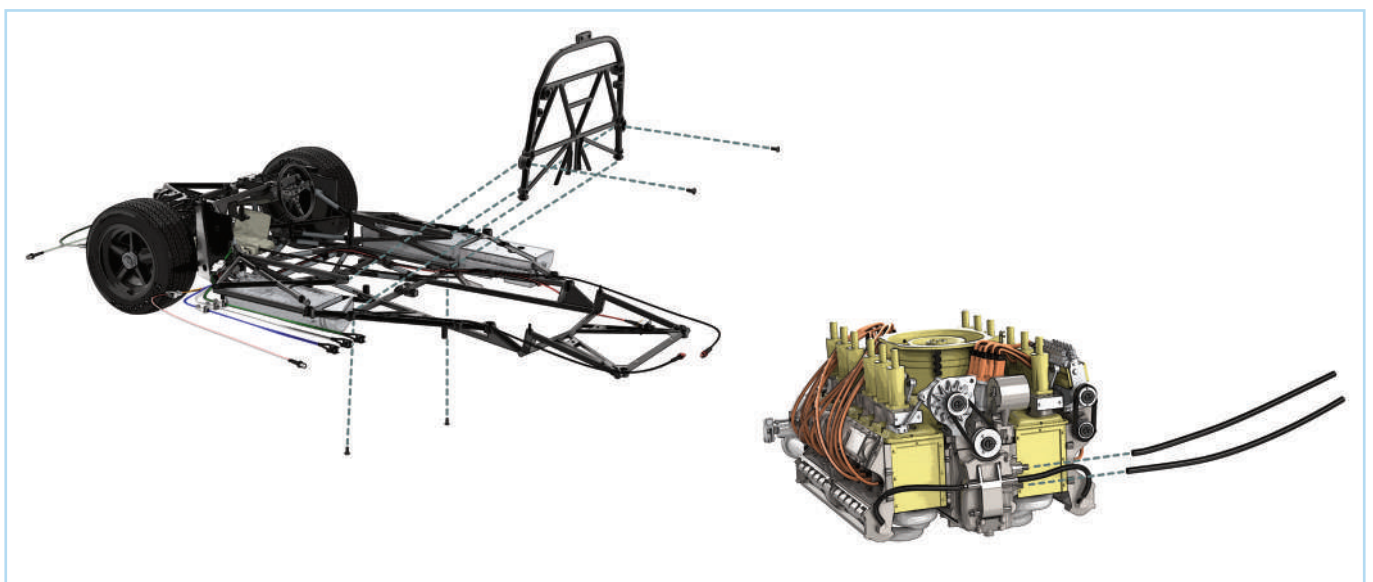

STAGE 37: FITTING THE COCKPIT PARTITION FRAME AND THE OIL HOSES

STEP 1

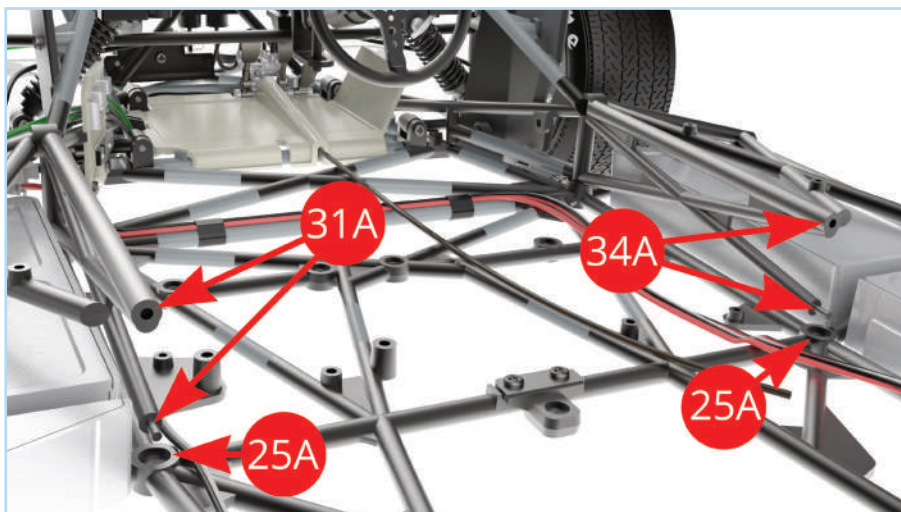

Take the chassis assembly and locate the indicated sockets in the left **tubular frame (31A)**, right **tubular frame (34A)** and the **chassis (25A)**.

Fit the **cockpit partition frame (37A)** onto the sockets identified in the image above. Note the orientation of the tab at the top, with the flat side facing towards the rear of the model (blue arrow).

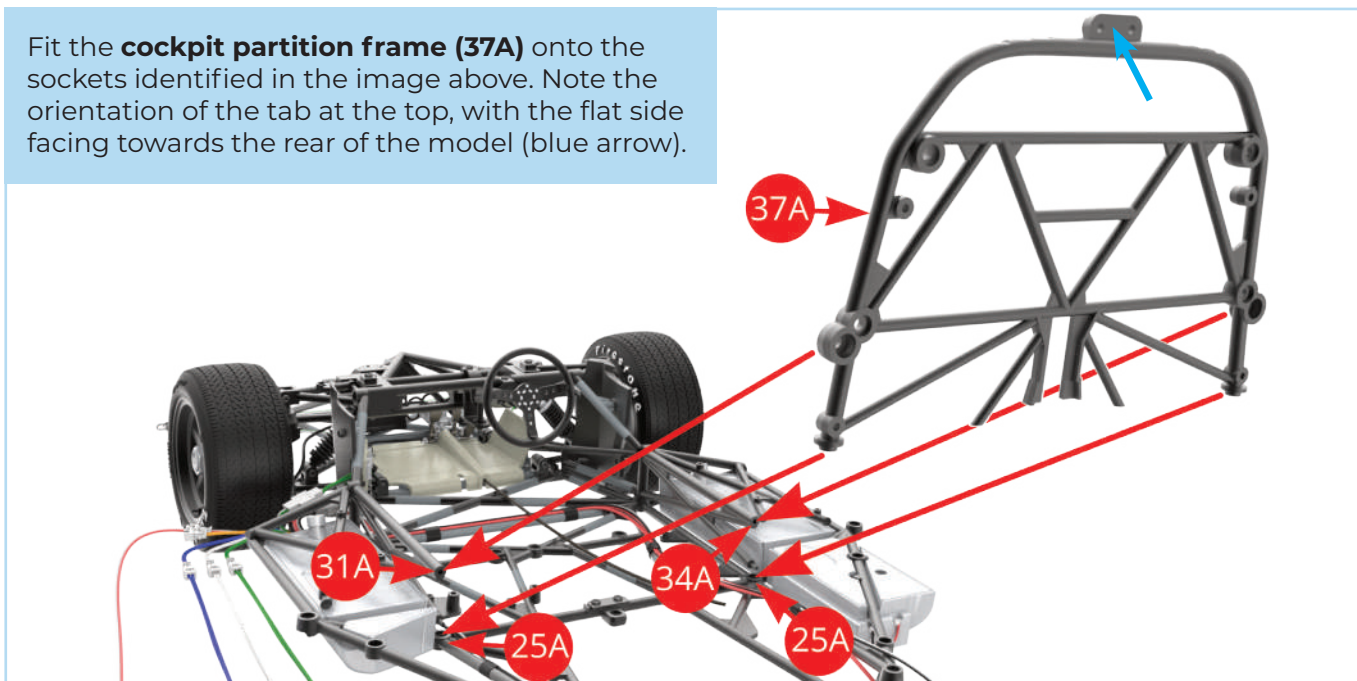

Fix the **cockpit partition frame (37A)** to the left and right frames (**31A and 34A**) using two **BM** screws.

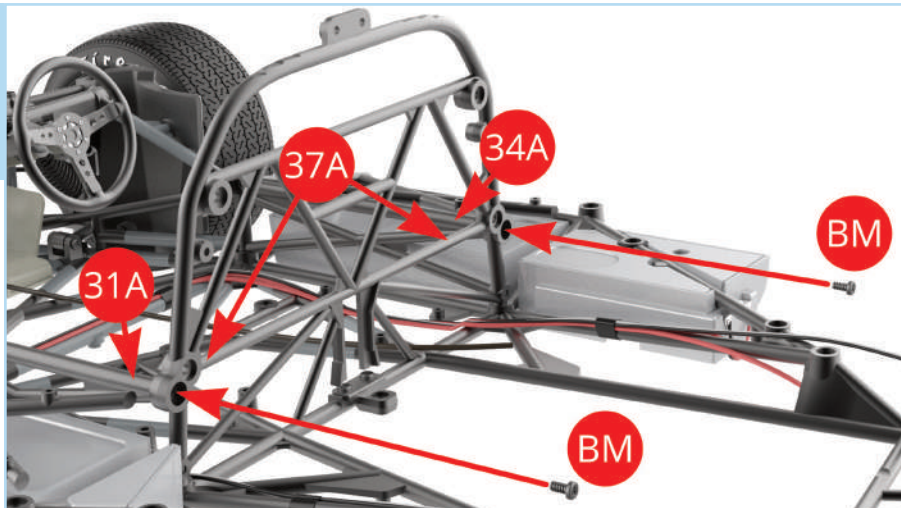

STAGE 37: FITTING THE COCKPIT PARTITION FRAME AND THE OIL HOSES

STEP 2

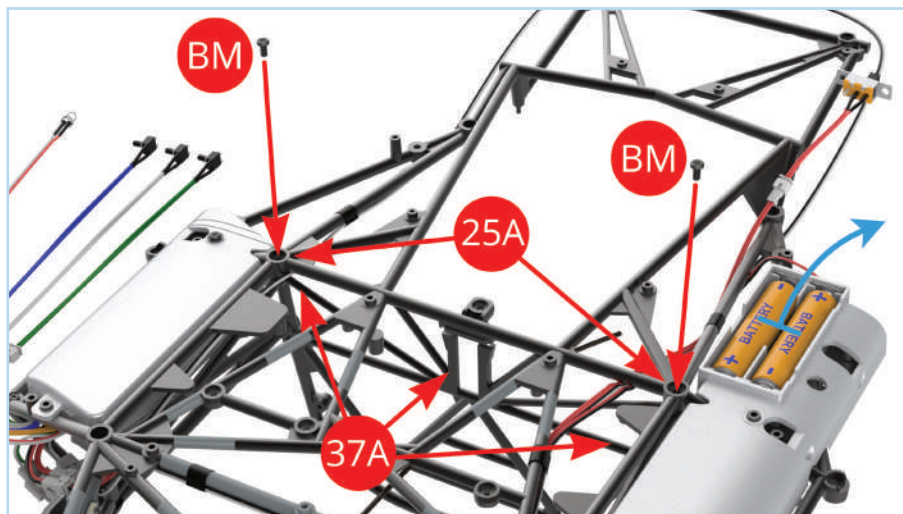

Turn the chassis assembly over and fix the partition frame to it using to **BM** screws. Remove the batteries from the compartment (blue arrow) until they are needed.

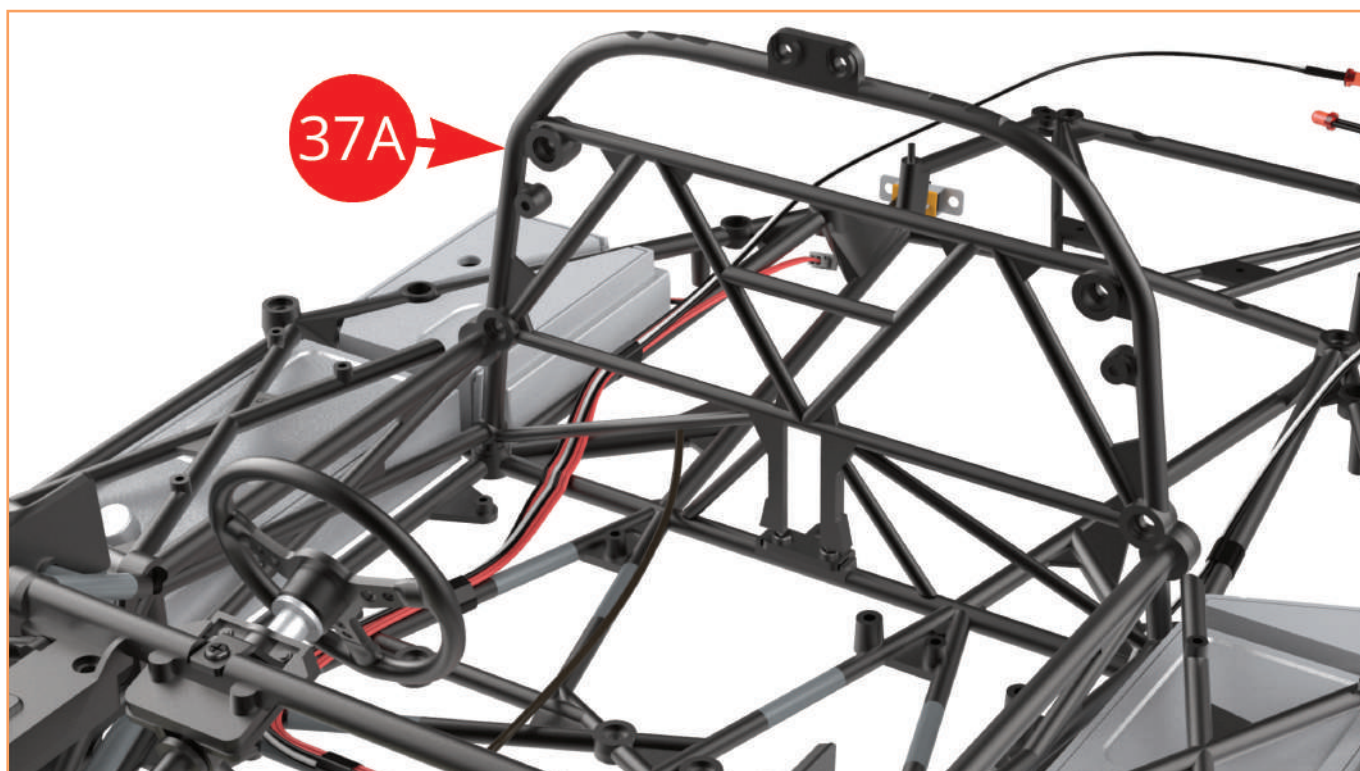

The cockpit partition frame has been installed onto the chassis.

STAGE 37: FITTING THE COCKPIT PARTITION FRAME AND THE OIL HOSES

STEP 3

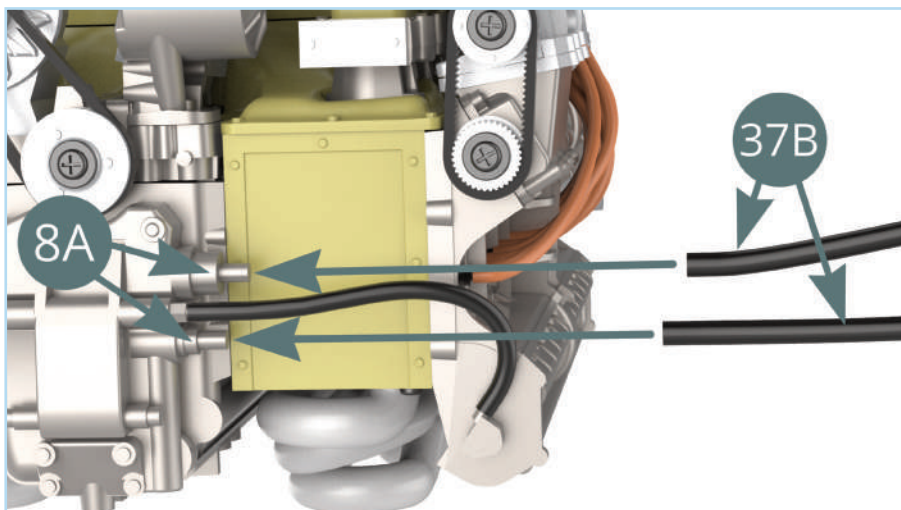

Take the engine assembly and fit the two **oil hoses (37B)** onto the pins of the **oil pump housing (8A)**.

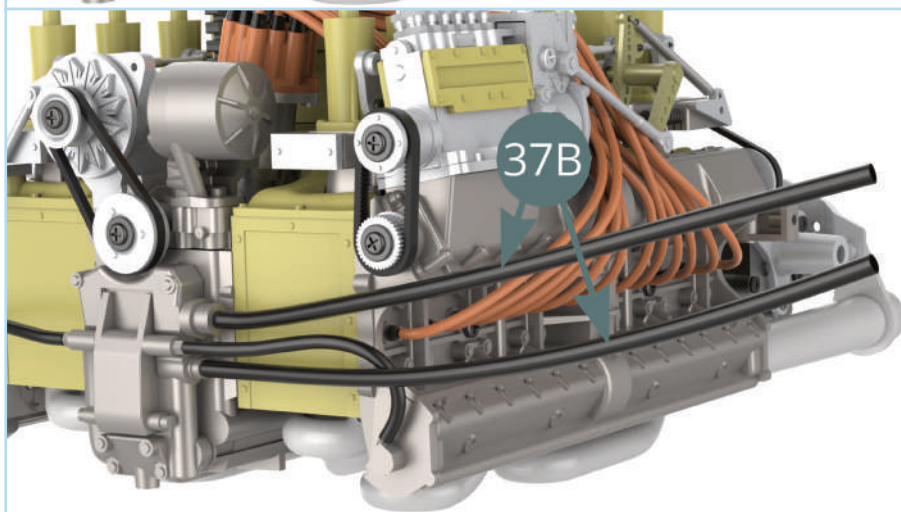

STAGE COMPLETE

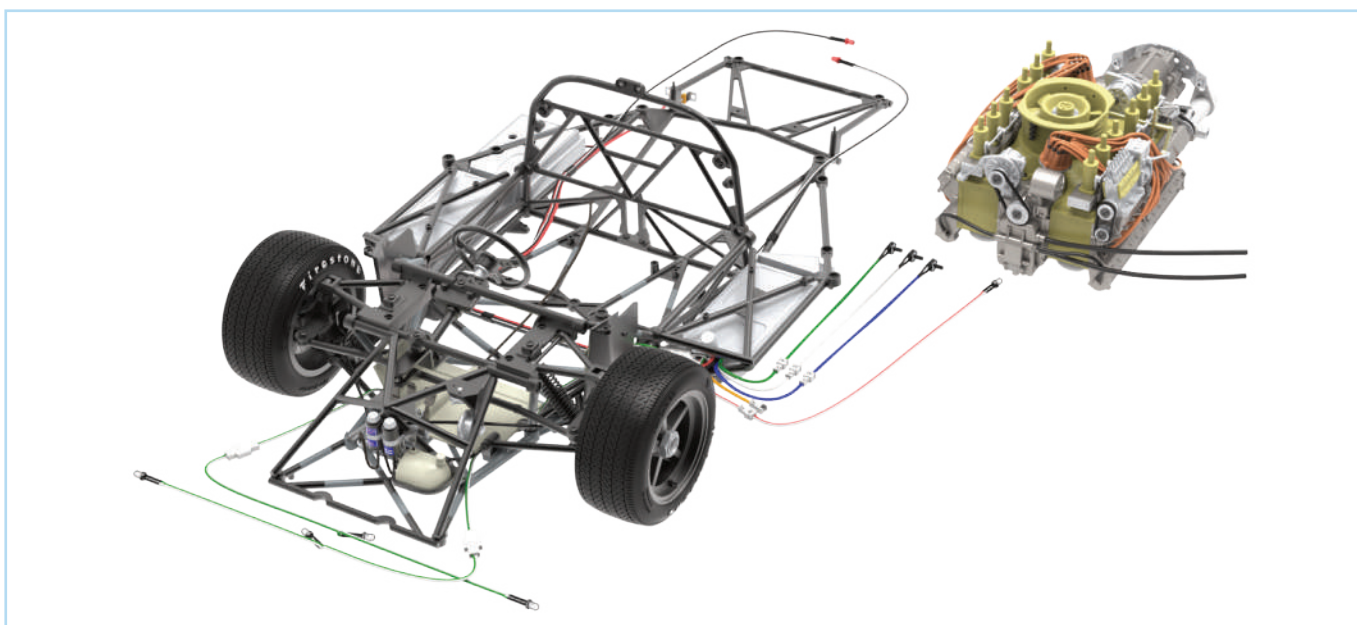

STAGE 37: FITTING THE COCKPIT PARTITION FRAME AND THE OIL HOSES

STAGE COMPLETE

