

STEVE MCQUEEN'S ICONIC **PORSCHE** **917KH**



Pack 12

BUILD INSTRUCTIONS

**STAGE 90: ATTACHING THE HINGES AND
TEST FITTING THE REAR HOOD**

**STAGE 91: FITTING THE AIR DUCTS AND
TRANSPARENT PLUG TO THE REAR HOOD**

**STAGE 92: ASSEMBLING AND ATTACHING
THE REAR CENTRE SPOILER**

**STAGE 93: PREPARING THE REAR HOOD
PANEL AND ATTACHING THE FUEL HOSES**

**STAGE 94: ASSEMBLING THE SPOILERS AND
ATTACHING THE REAR HOOD PANEL**

**STAGE 95: FITTING THE COCKPIT
VENTILATION PIPES AND THE FRONT BODY**

**STAGE 96: ASSEMBLING AND ATTACHING
THE LEFT SIDE FAIRING**

**STAGE 97: ASSEMBLING AND ATTACHING
THE RIGHT SIDE FAIRING**

**STAGE 98: ADDING THE DOOR SILLS
AND TRIMS**

**STAGE 99: FITTING THE SPEAKER, THE
SWITCH AND THE BOTTOM PANEL**

STAGE 100: APPLYING THE FINAL DECALS

Porsche, the Porsche shield and the distinctive design of Porsche cars are trademarks and trade dress of Porsche AG. Permission granted.

The Gulf trademarks are used under license from Gulf Oil International Ltd.

Personality rights of Steve McQueen are used with permission of Chadwick McQueen and The Terry McQueen Testamentary Trust.

Represented exclusively by Greenlight.

AGORA
MODELS

Advice from the experts

Spare screws are included with each part. Occasionally, you may be instructed to keep spare or unused screws for a later stage. Keep these spares in a safe place and label them correctly.

Please make sure you don't mix up the screws. They look quite similar, but the threads do vary slightly. Using the wrong screws may damage the parts.

When securing parts together using multiple screws, fit each screw loosely to ensure all the parts are correctly aligned before gently tightening them firmly, but not overtight, in the order in which you placed them.

The screwdriver can be magnetized by stroking it with a magnet (fridge magnet, etc.) enabling it to hold the screws and make assembly easier.

If a screw is tight going into a metal part, do not force it as you may shear the head off. Remove it and put a tiny smear of Vaseline, soap or light oil on the thread. That will lubricate it and make it easier to drive home.

During the course of this build, you will receive many pieces that you will assemble immediately – following the instructions in the corresponding stage – and other pieces that you should store safely to one side, for use in future assembly stages.

Left and Right! When building your Porsche 917KH, the left or right hand side refers to each side as you are sitting in the car.



WARNING: Some parts are assembled using magnets. These magnets can cause serious injury if they are swallowed. Keep away from children. If you suspect a magnet has been swallowed, seek medical help straight away.

STAGE 90: ATTACHING THE HINGES AND TEST FITTING THE REAR HOOD

90A Rear hood

90B Hinge clamp (x2)

90C Transparent tape (x2)

PM Screw 2.0 x 4 mm (x5)

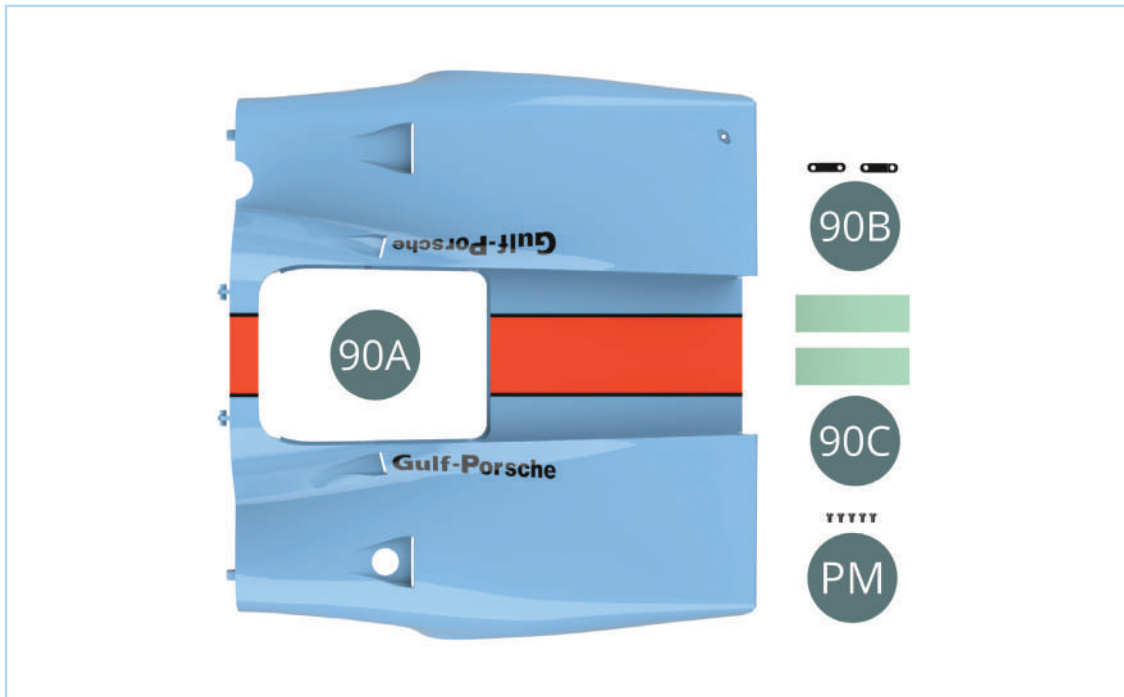

ASSEMBLY DIAGRAM

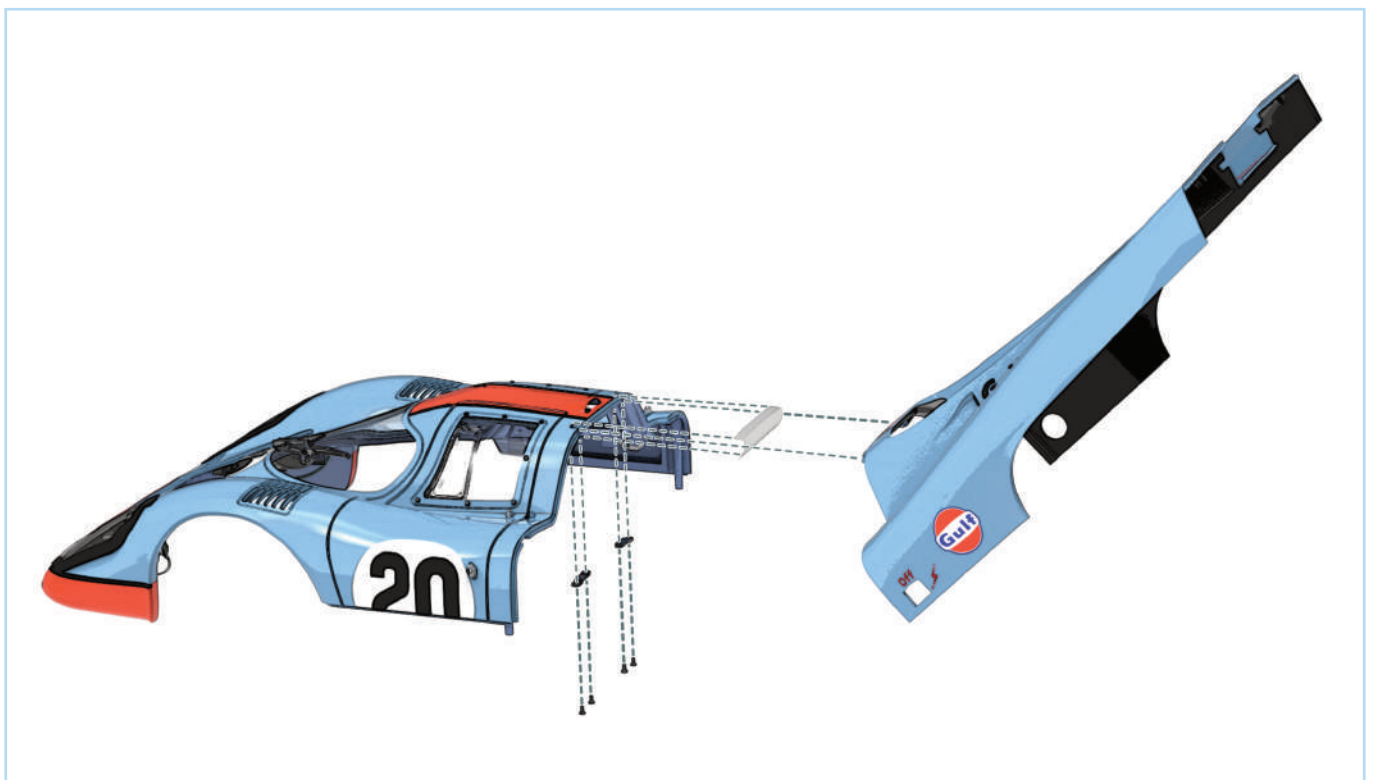

STAGE 90: ATTACHING THE HINGES AND TEST FITTING THE REAR HOOD

STEP 1

Retrieve the front body assembly. Fit the two **hinge clamps (90B)** to the underside of the **front body (80A)** and fasten using four **PM** screws.

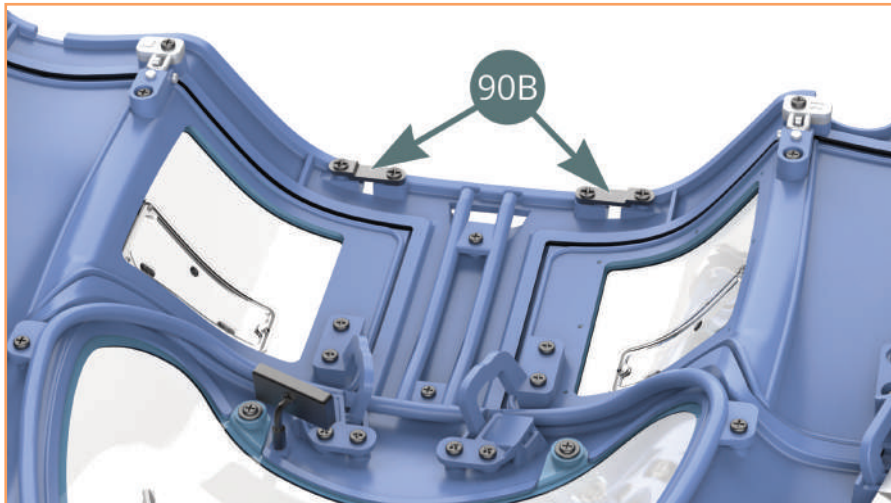
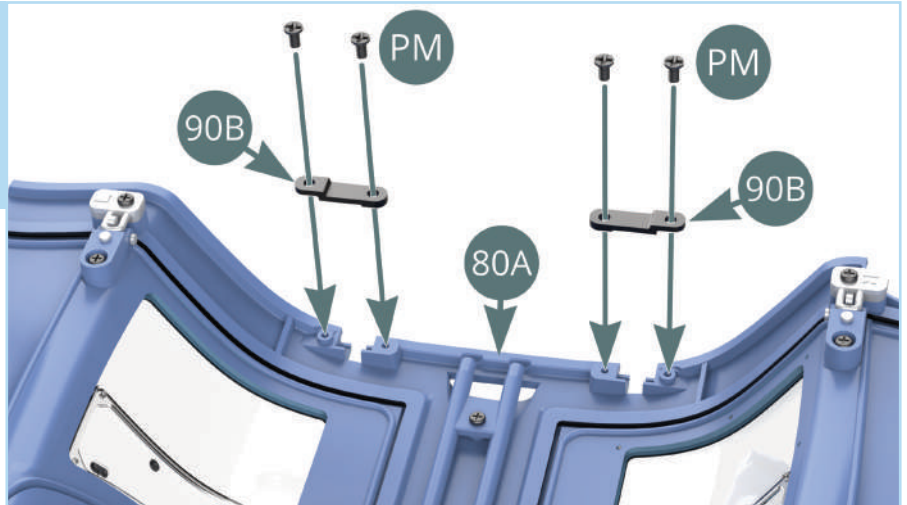

The hinge clamps should look like this once fastened to the front body.

STEP 2

Remove a piece of **transparent tape (90C)** from its backing paper as indicated by the blue arrow.

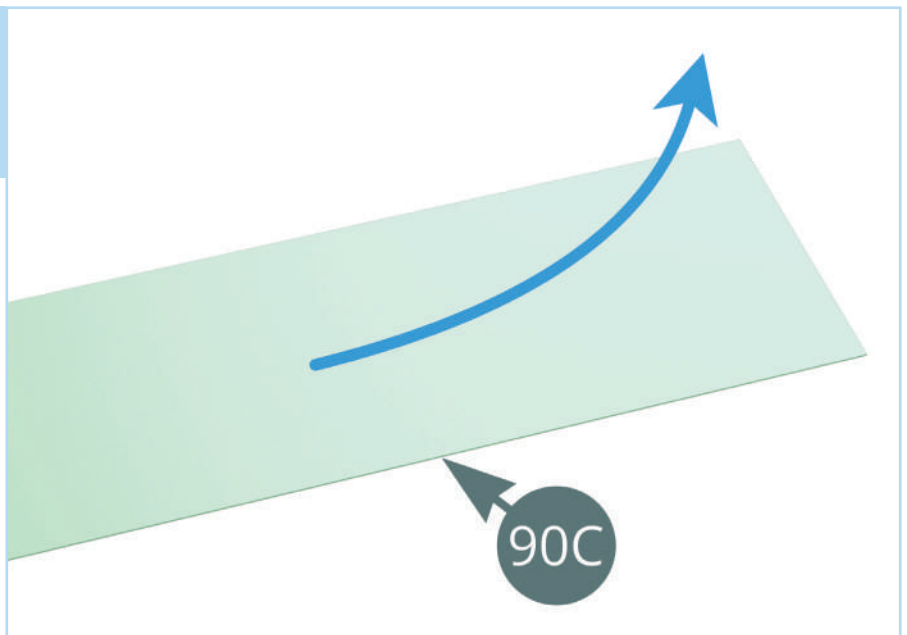

STAGE 90: ATTACHING THE HINGES AND TEST FITTING THE REAR HOOD

Wrap the **transparent tape (90C)** around the edge of the **front body (80A)** (green arrows), aligning the edges of the tape with the joints (red arrows). This will help protect the paint while you test fit the rear hood.

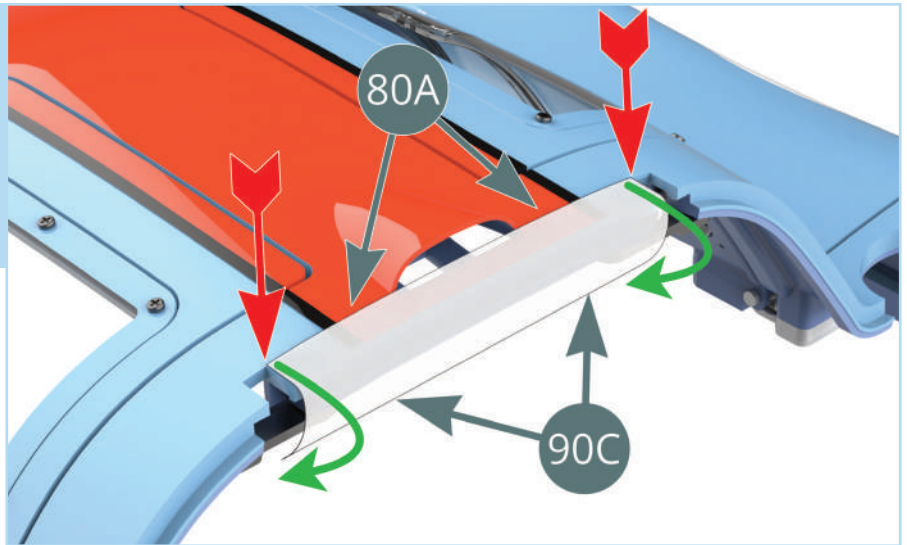

STEP 3

Align the **rear hood (90A)** with the **front body (80A)** at a 45 degree angle as shown. Keeping it at this angle, insert the two hinges of the hood into the body (red arrow). Once in place, move the hood to the horizontal position, as indicated by the green arrow.

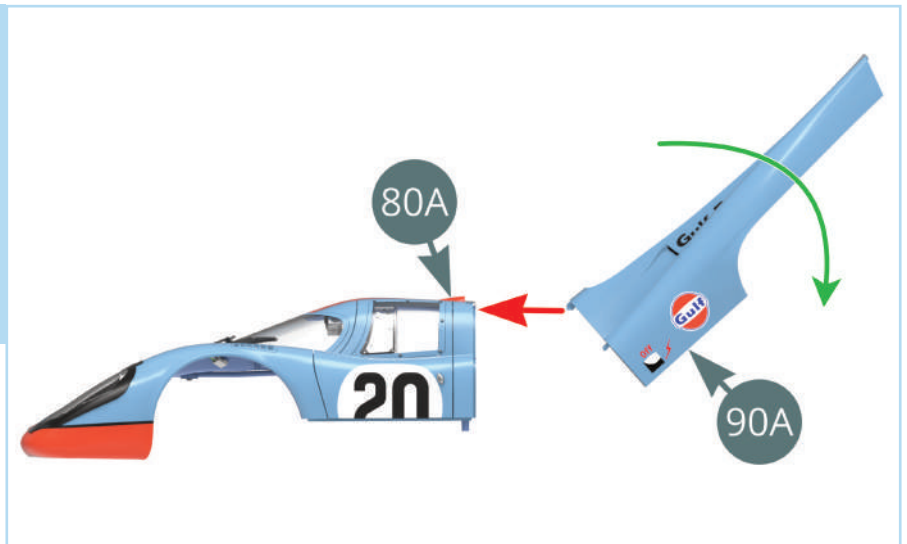

The rear hood should fit flush against the front body as shown in this image.

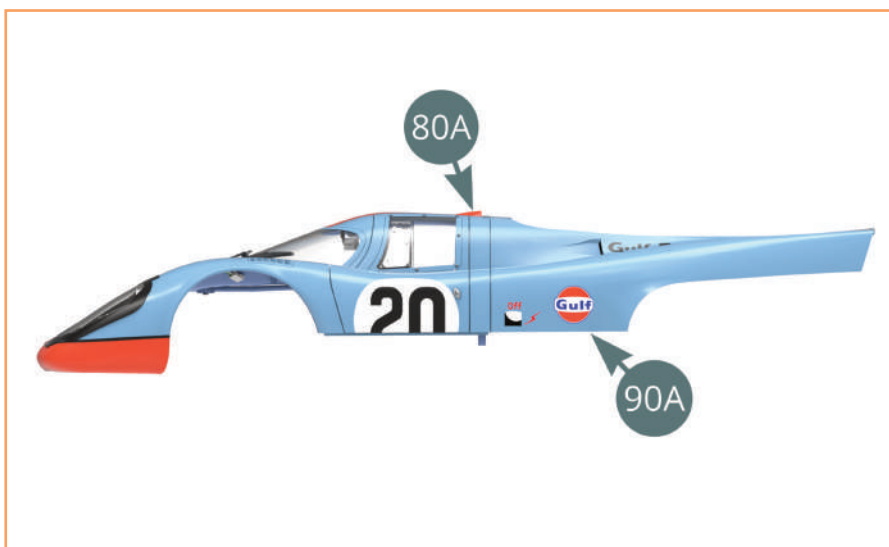

STAGE 90: ATTACHING THE HINGES AND TEST FITTING THE REAR HOOD

STEP 4

Once you have tested the fit of the rear hood, raise it back to a 45 degree angle and pull it away from the front body. Store the parts in a safe place until they are needed later.

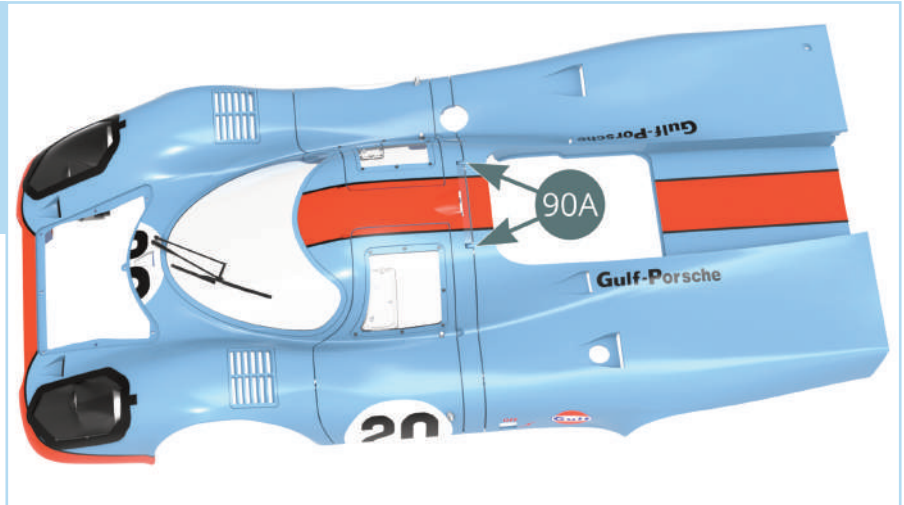

STAGE COMPLETE

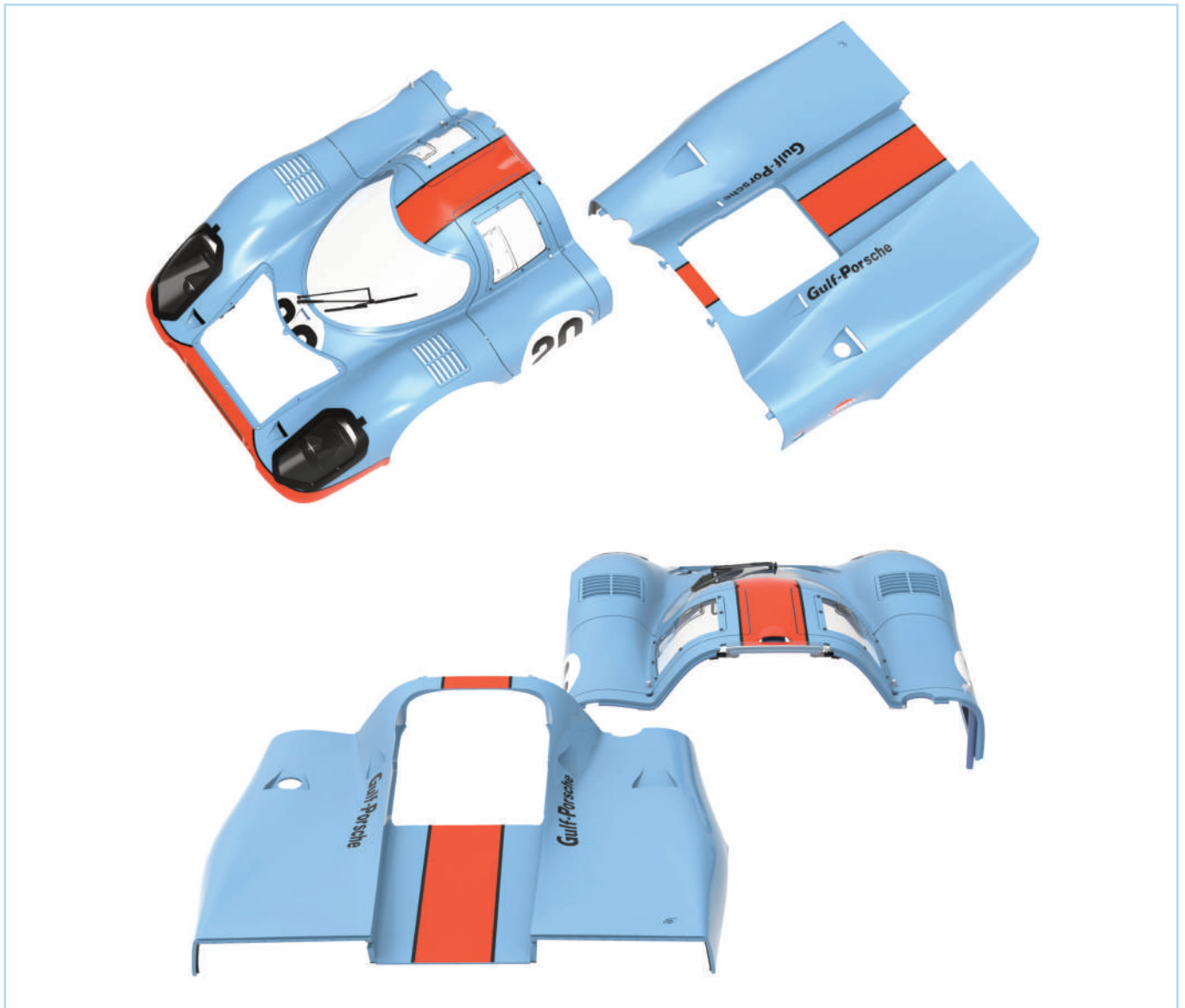

STAGE 91: FITTING THE AIR DUCTS AND TRANSPARENT PLUG TO THE REAR HOOD

91A Left air duct

IM Screw 1.7 x 3.5 mm (x5)

91B Right air duct

91C Transparent plug

91D Double-sided tape ring (x2)



ASSEMBLY DIAGRAM

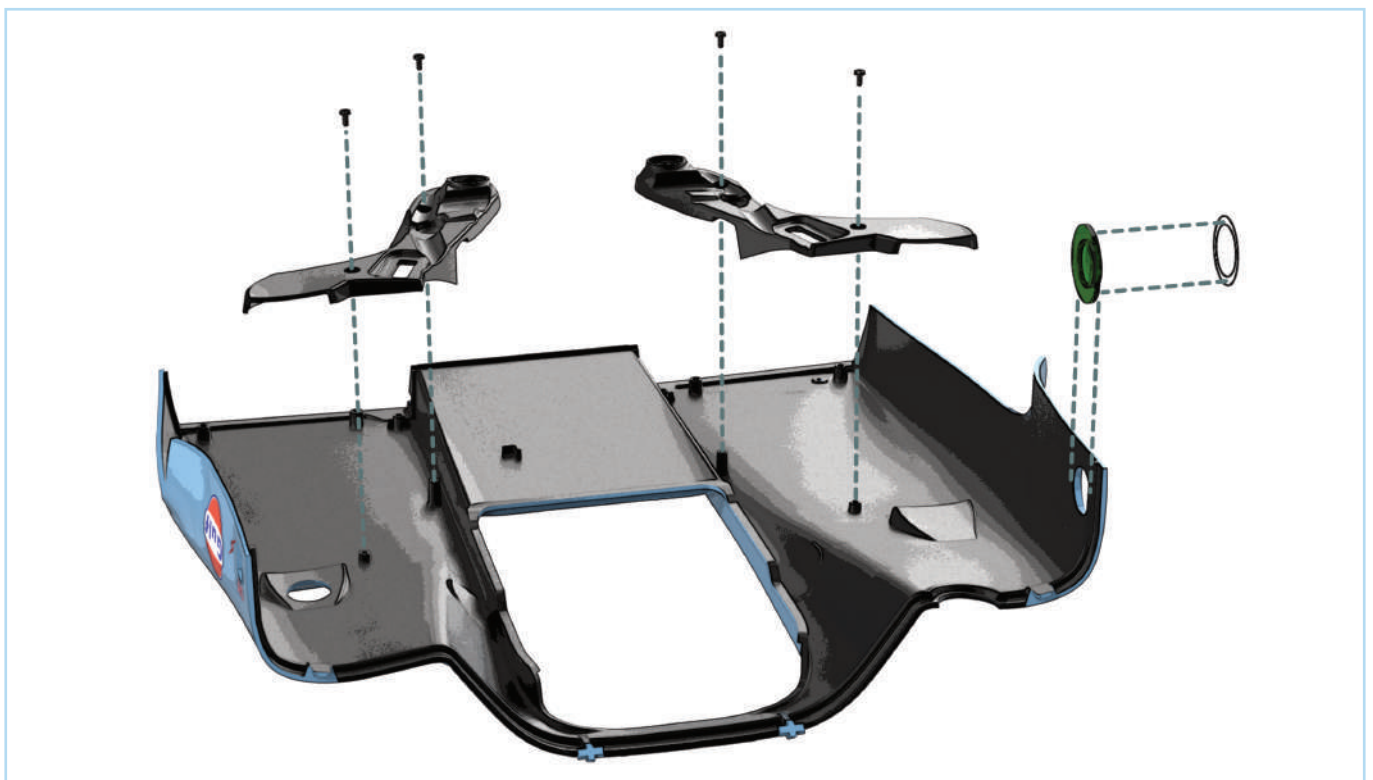

STAGE 91: FITTING THE AIR DUCTS AND TRANSPARENT PLUG TO THE REAR HOOD

STEP 1

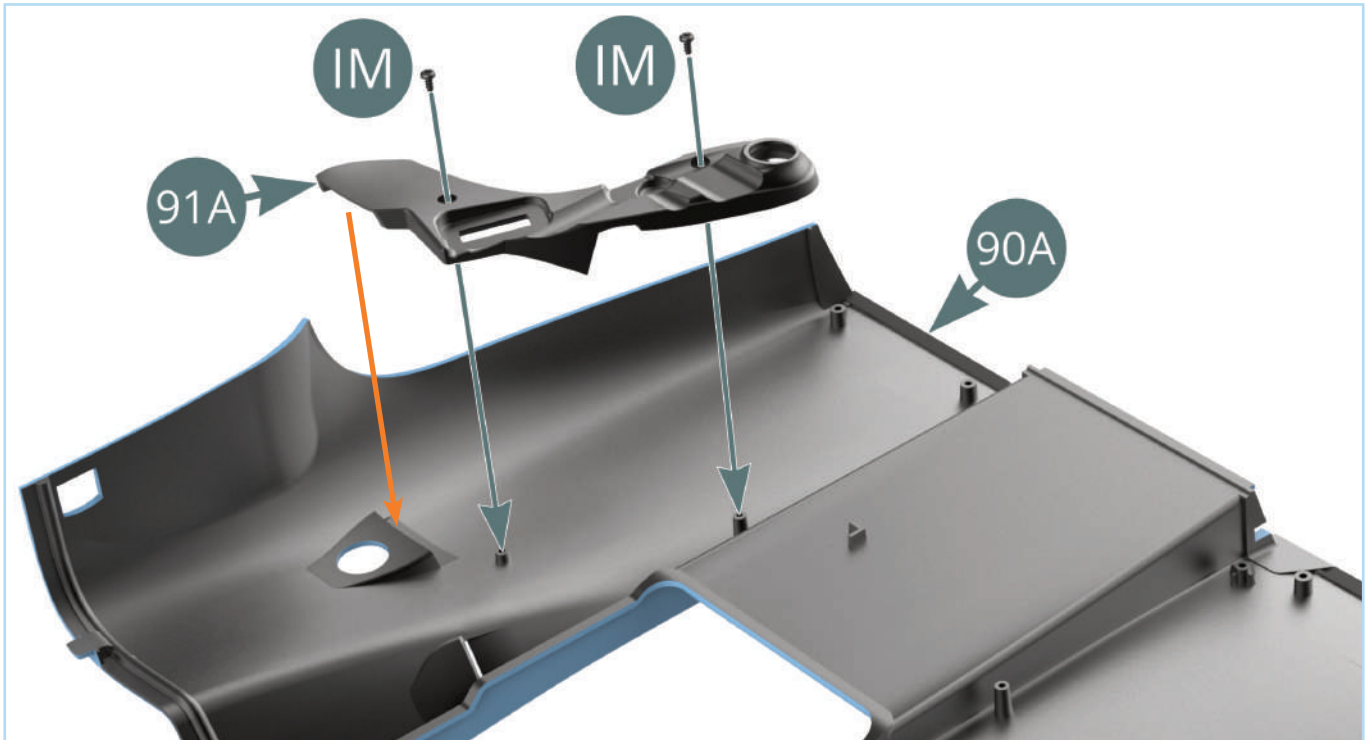

Fit the **left air duct (91A)**, marked with an 'L', to the underside of the **rear hood (90A)** as shown and secure in place using two **IM** screws. The lip of the air duct should align with the vent in the hood (orange arrow).

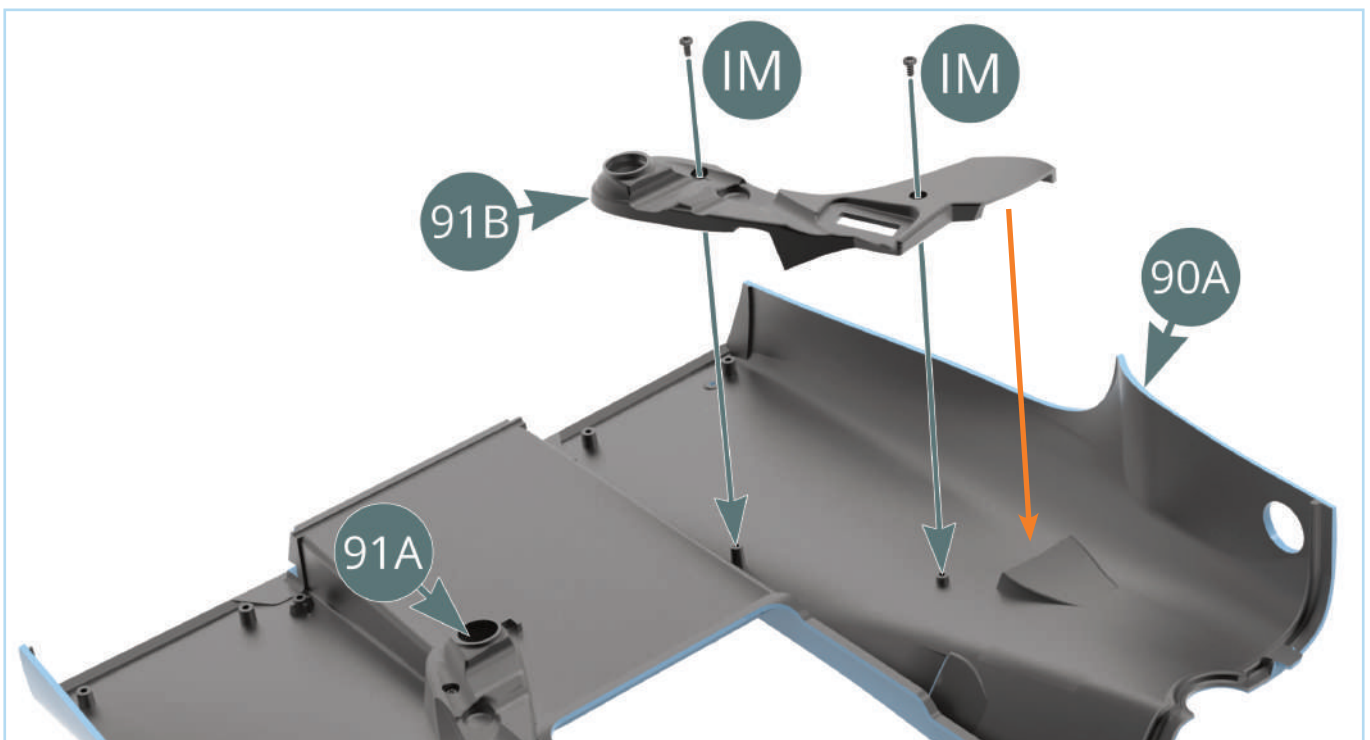

Fit the **right air duct (91B)**, marked with an 'R', on the opposite side of the **rear hood (90A)** and secure in place using two **IM** screws. As with the previous air duct, the lip should align with the vent in the hood (orange arrow).

STAGE 91: FITTING THE AIR DUCTS AND TRANSPARENT PLUG TO THE REAR HOOD

STEP 2

Peel the backing paper from one side of a **double-sided tape ring (91D)** (blue arrow) and stick the tape onto the **transparent plug (91C)** in the orientation shown.

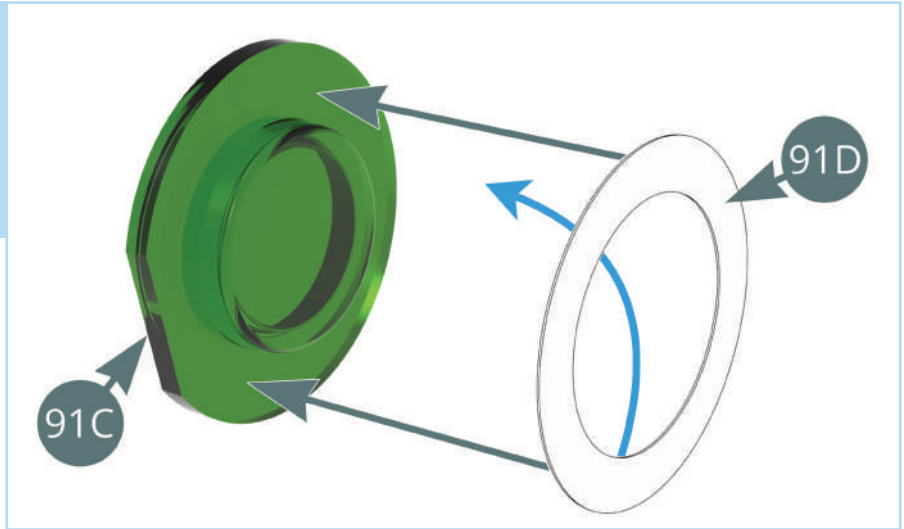

Peel the piece of backing paper from the other side of the **double-sided tape ring (91D)** (blue arrows) and use the adhesive to stick the **transparent plug (91C)** into the hole on the left inner side of the **rear hood (90A)**. Make sure to orient the plug so that the flat edge fits against the ridge of the hood (red arrows).

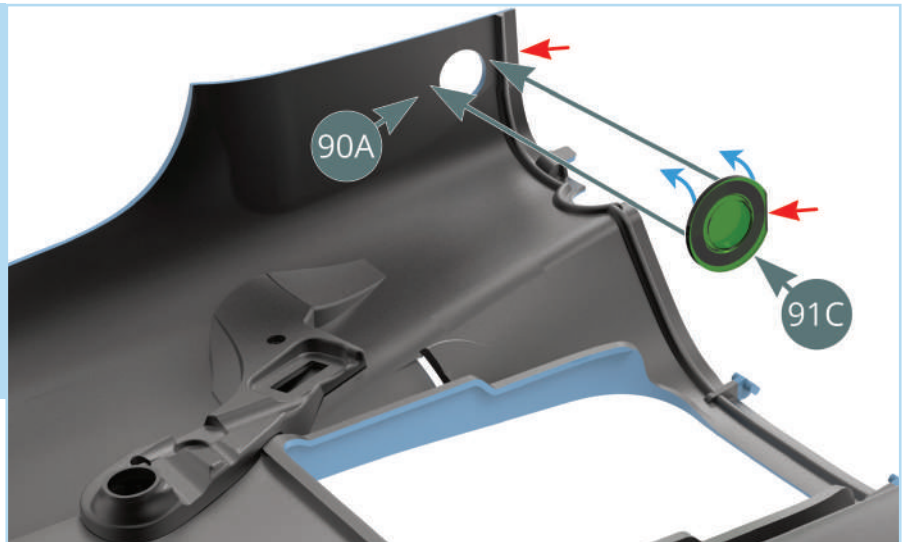

The air ducts and transparent plug have been installed onto the rear hood.

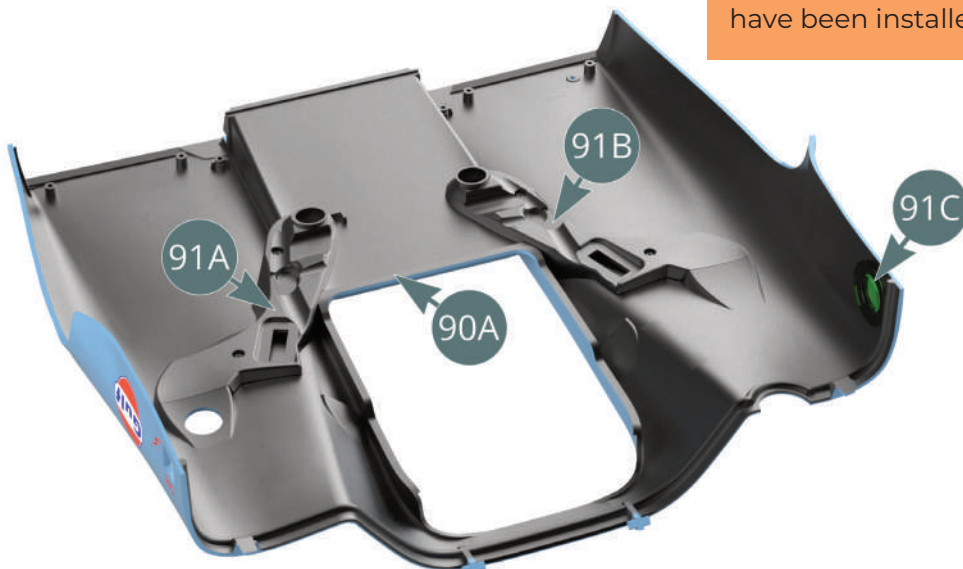

STAGE 91: FITTING THE AIR DUCTS AND TRANSPARENT PLUG TO THE REAR HOOD

STAGE COMPLETE



STAGE 92: ASSEMBLING AND ATTACHING THE REAR CENTRE SPOILER

92A Centre spoiler top

KM Screw 1.7 x 3 x 5 mm (x3)

92B Centre spoiler bottom

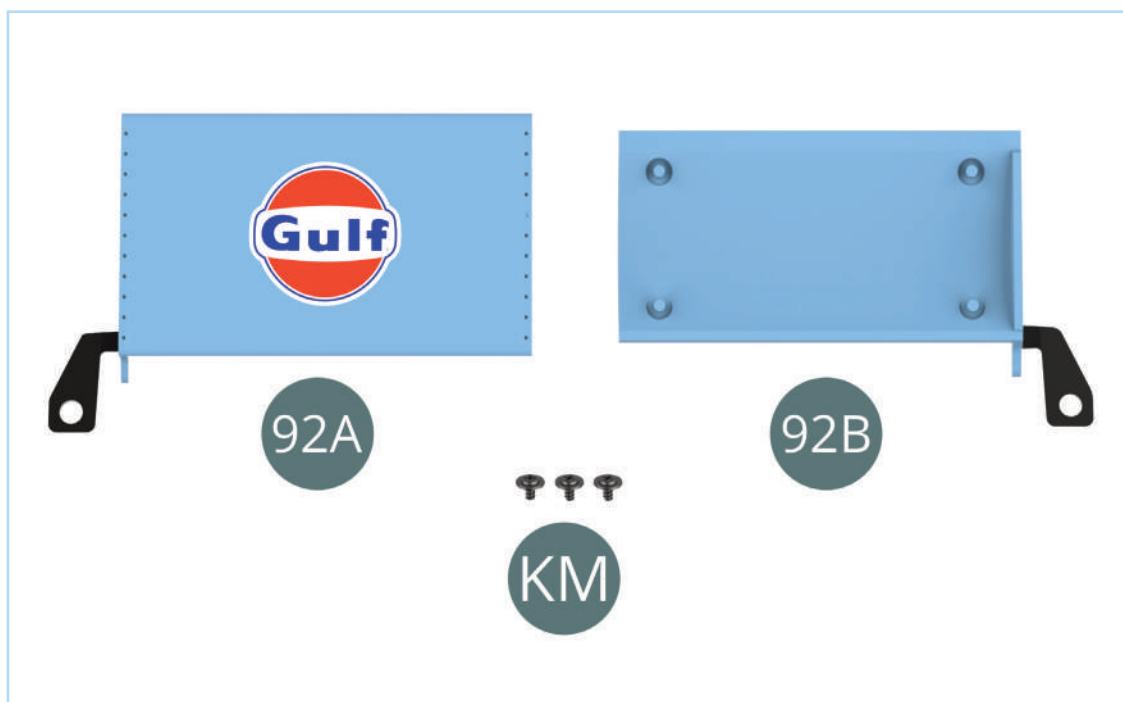

ASSEMBLY DIAGRAM

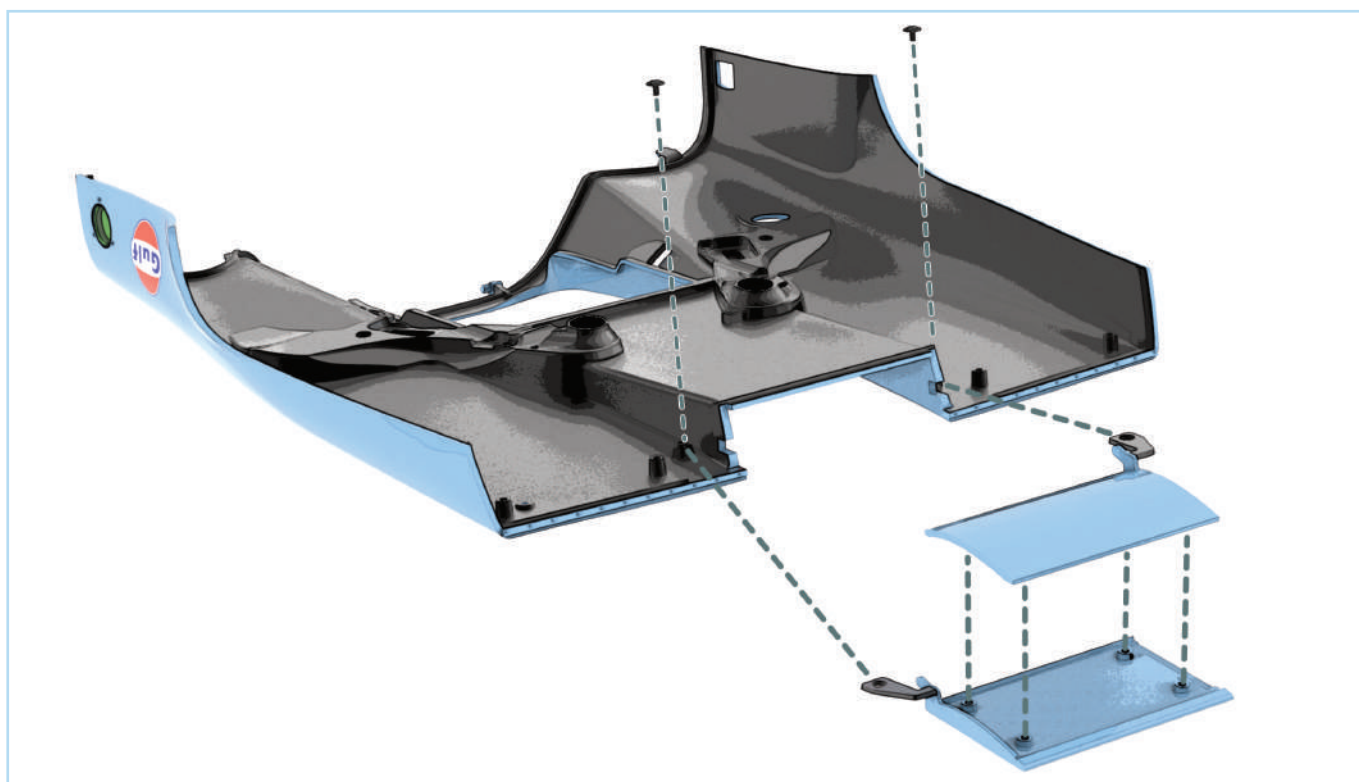

STAGE 92: ASSEMBLING AND ATTACHING THE REAR CENTRE SPOILER

STEP 1

Fit the **centre spoiler bottom (92B)** onto the **centre spoiler top (92A)** by pressing the pins into the holes as shown.

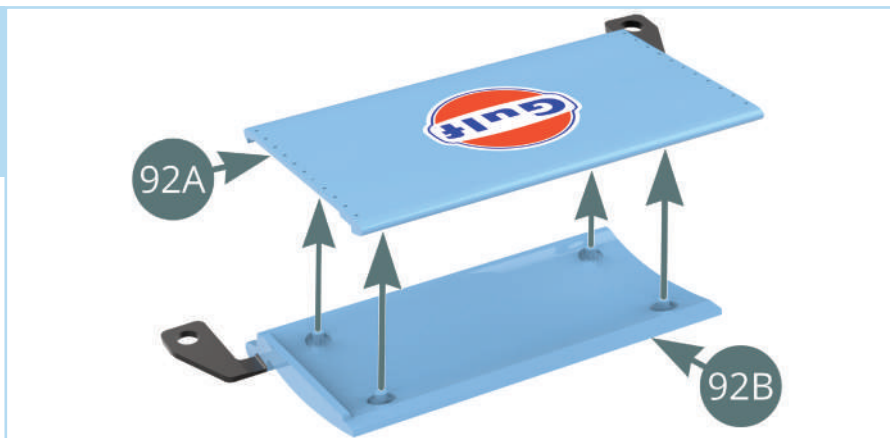

Align the centre spoiler with the **rear hood (90A)** as shown. Fit the holes of the **centre spoiler bottom (92B)** over the indicated screw holes of the rear hood.

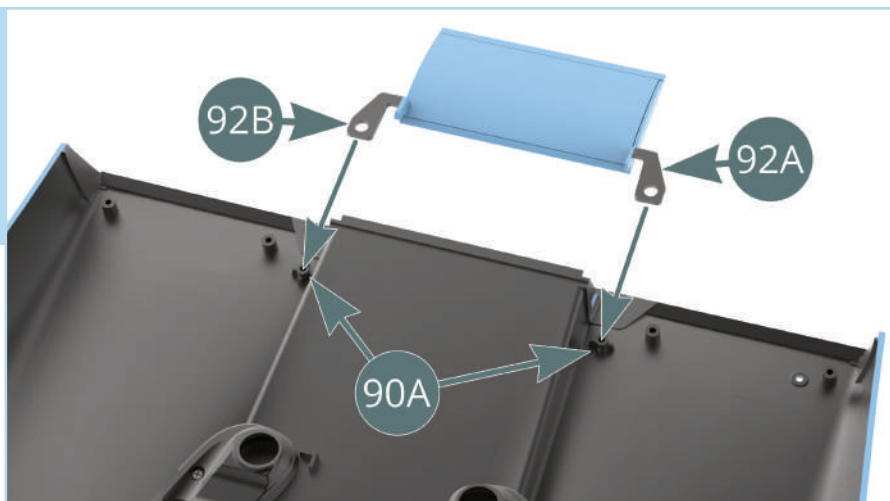

STEP 2

Fasten the centre spoiler to the rear hood using two **KM** screws. Don't overtighten the screws, the spoiler should be able to move slightly up and down once fastened.

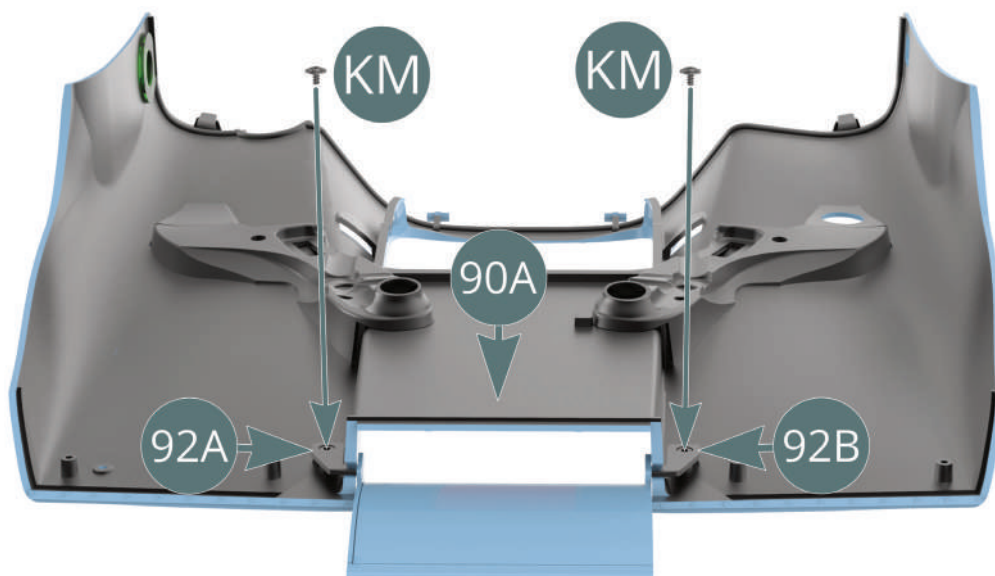

STAGE 92: ASSEMBLING AND ATTACHING THE REAR CENTRE SPOILER

STAGE COMPLETE

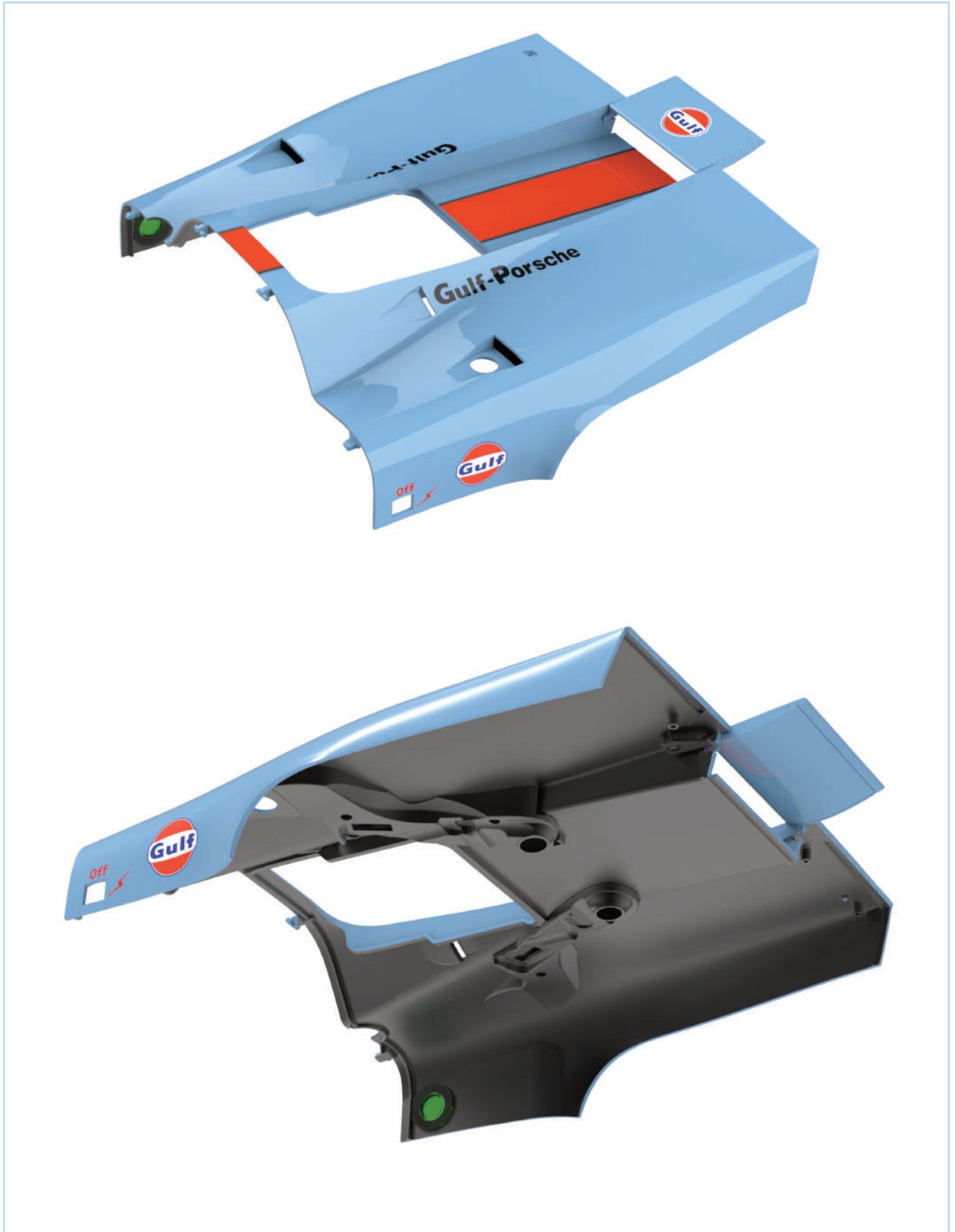

STAGE 93: PREPARING THE REAR HOOD PANEL AND ATTACHING THE FUEL HOSES

93A Rear hood panel

93B Lock base (x2)

93C Lock (x2)

93D Fuel hose (long)

93E Fuel hose (short)

93F Fuel breather hose

AP Screw 1.7 x 4 mm (x3)

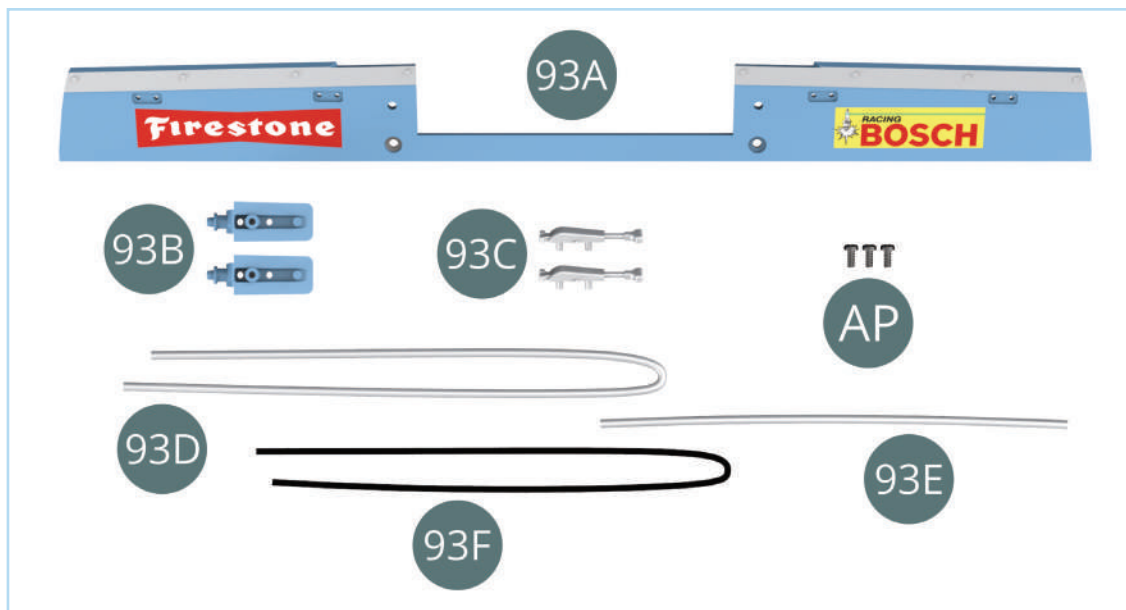

The fuel hoses **93D**, **93E** and **93F** are contained in a separate bag marked with the part numbers inside your pack. These are replacement parts for your model.

ASSEMBLY DIAGRAM

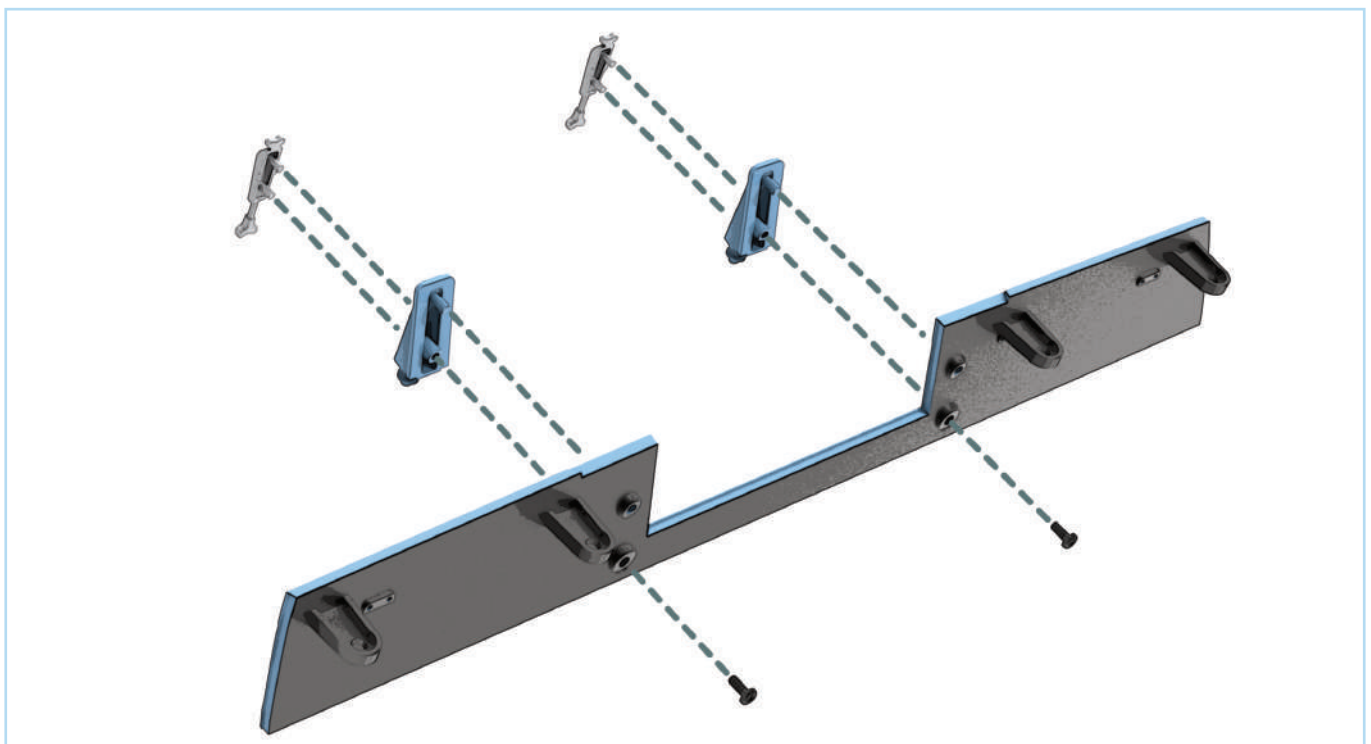

STAGE 93: PREPARING THE REAR HOOD PANEL AND ATTACHING THE FUEL HOSES

STEP 1

Take the two **locks (93C)** and the two **lock bases (93B)** and align the parts as shown. Firmly press the pins of the locks into the corresponding holes of the bases.

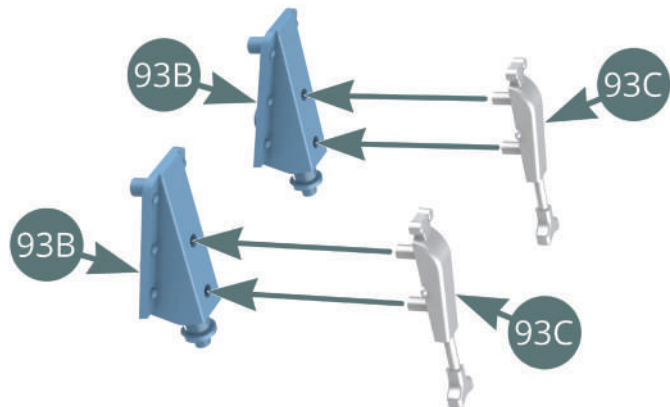

Next align the two **lock bases (93B)** with the **rear hood panel (93A)** and press the bases into the panel. Secure the parts together using two **AP screws**.

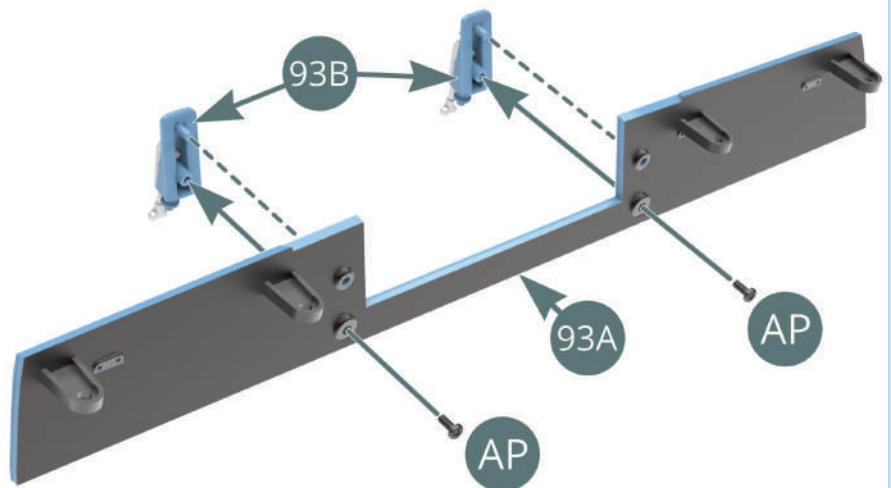

STEP 2

On the left side of the chassis, detach the **fuel hose (70F)** and the **braided fuel line (70G)** (highlighted red) along with the **connector (70E)**. Then detach the **fuel hose (38C)** and the **connector (38D)**. The red arrows indicate the direction to gently pull in to remove these parts.

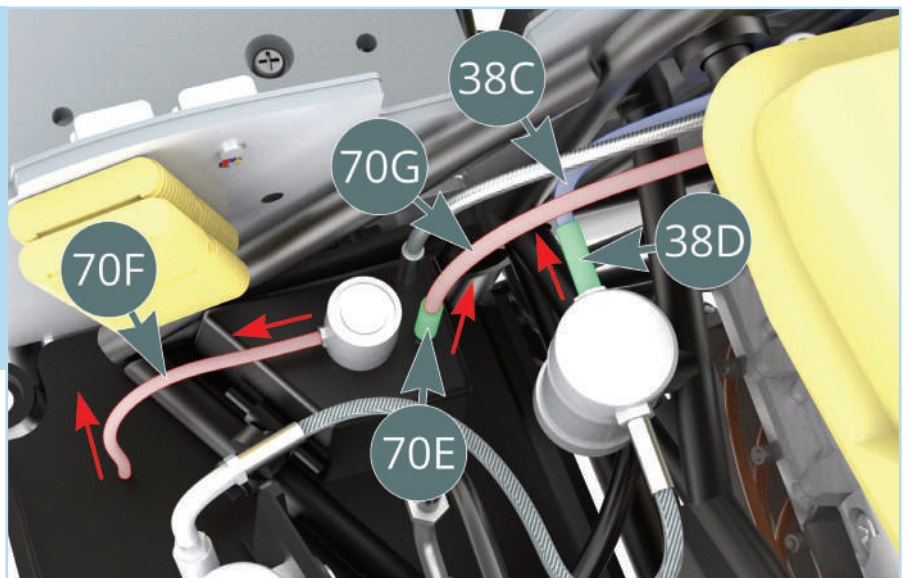

STAGE 93: PREPARING THE REAR HOOD PANEL AND ATTACHING THE FUEL HOSES

On the right side of the chassis, detach the **braided fuel line (38C)** and its **connector (75I)** (highlighted in blue and green). Remove the **fuel hose (73G)** (highlighted in red). Then detach the **braided fuel line (70G)** and its **connector (75I)** (highlighted in red and green) and reattach it to the Y branch (**39B**) (red arrow). Remove the other **braided fuel line (70G)** highlighted in yellow, and set the **connector (75I)** aside.

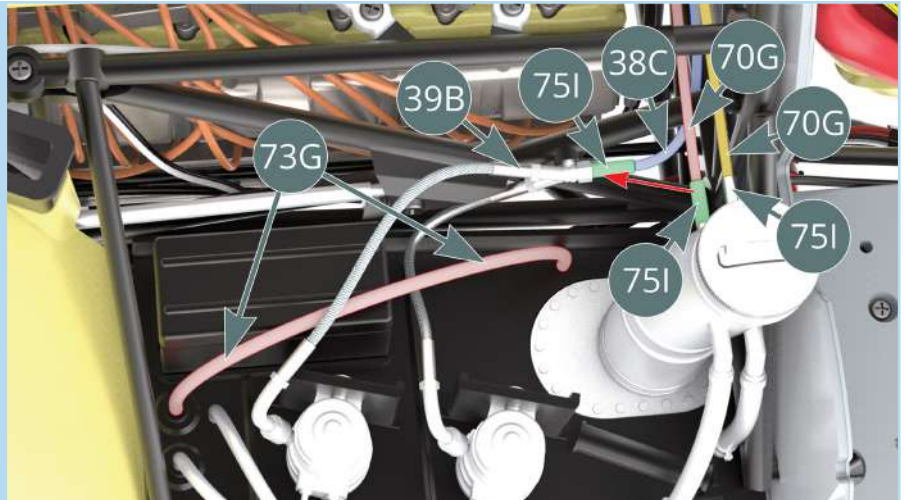

STEP 3

Next attach the **fuel line (93D)** (highlighted green) to the pin of the **right chassis plate (73A)** and feed it through to the other side along the front of the engine. Fit a **connector (75I)** to the **fuel breather hose (93F)** and fit it onto the **fuel filler neck (75B)** and guide it through to the other side in the same way as before.

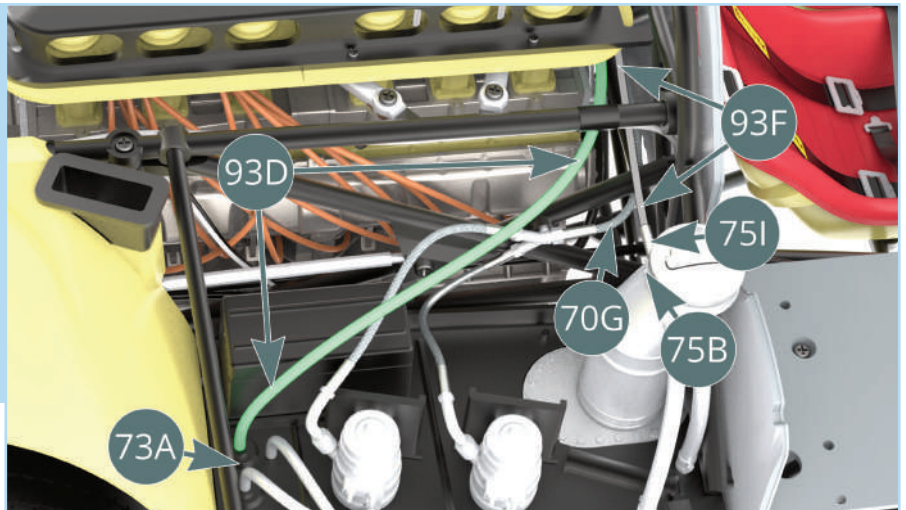

On the left side of the chassis, attach the **fuel hose (93D)** (highlighted green) to the **fuel filter (38B)**. Attach the **fuel breather hose (93F)** to the **cap (70C)**. Take the **fuel hose (93E)** and fit it onto the **fuel manifold (70B)** and **fuel pump (69B)** as shown.

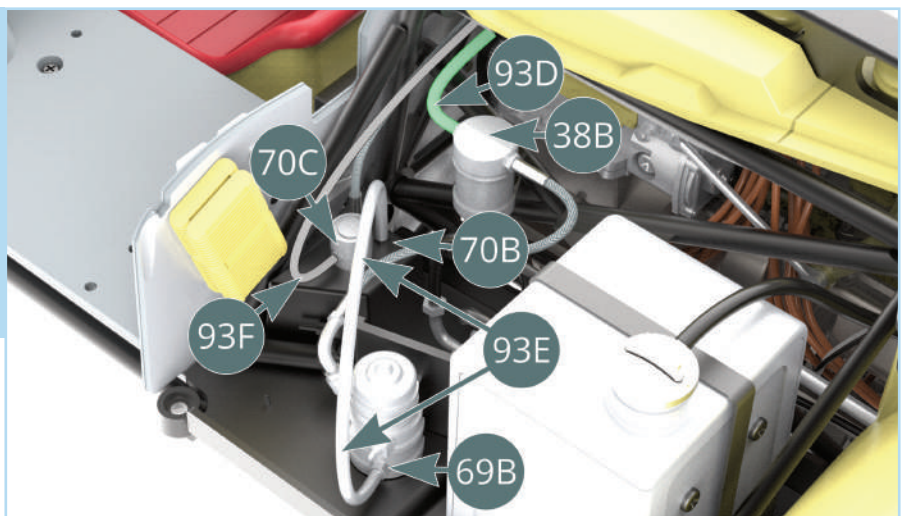

STAGE 93: PREPARING THE REAR HOOD PANEL AND ATTACHING THE FUEL HOSES

The fuel hoses have been refitted on the left and right sides of the chassis. Check the images below carefully for the arrangement of the fuel hoses.

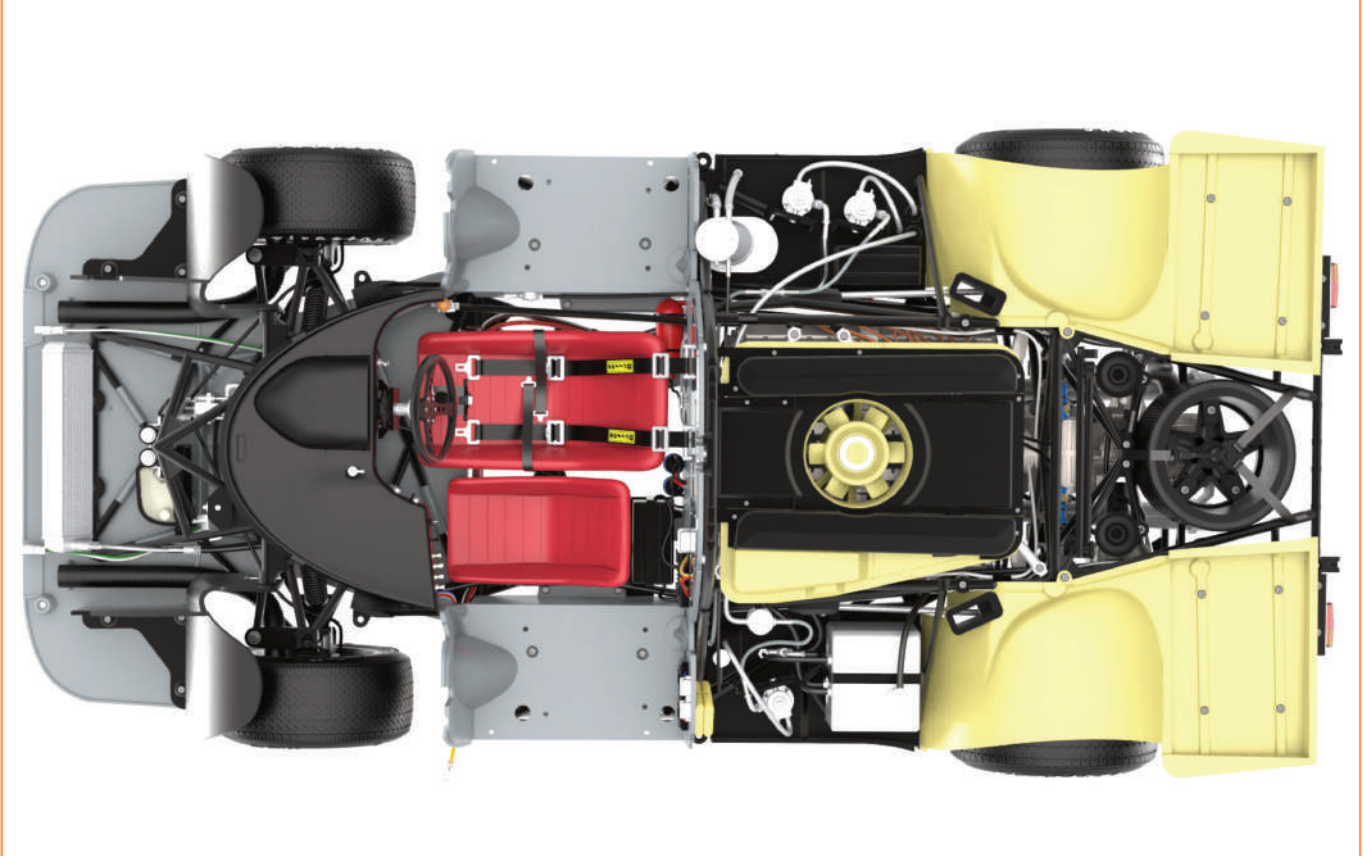
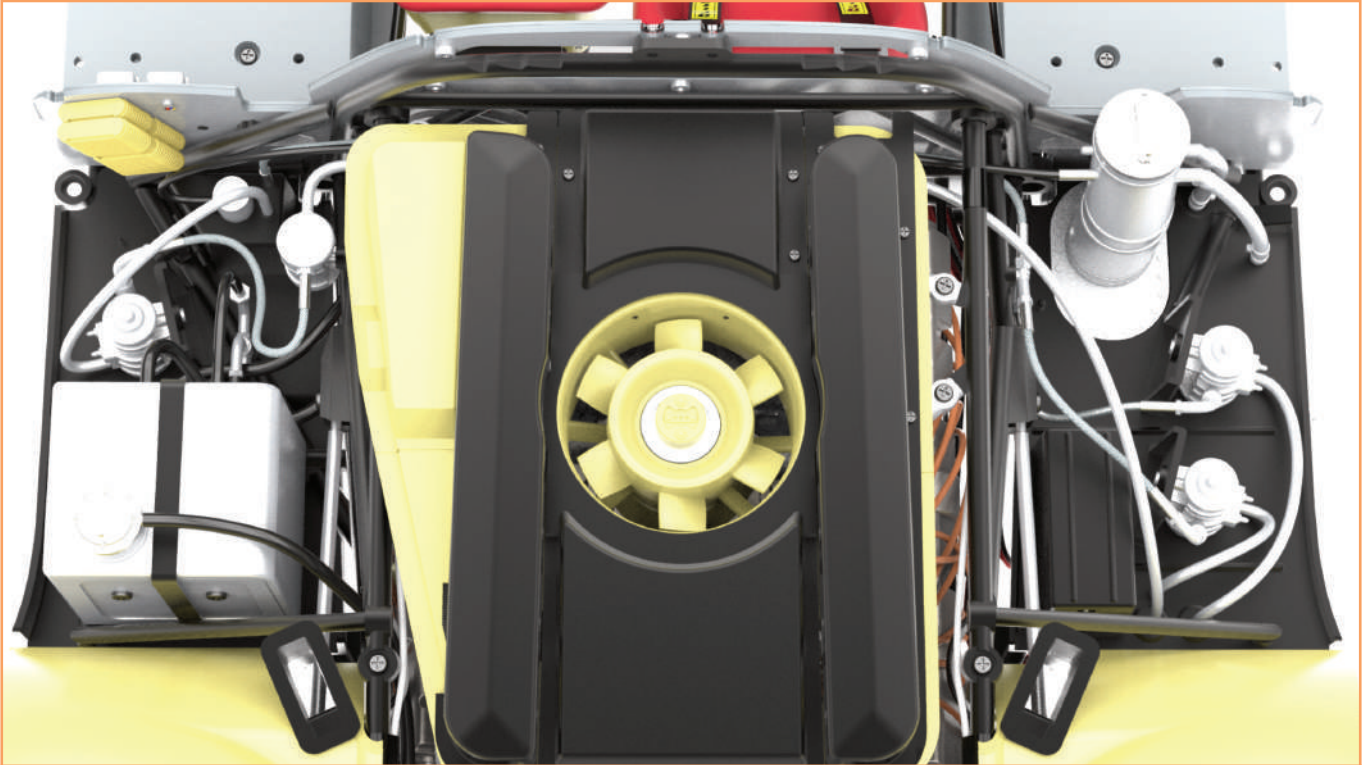

STAGE 93: PREPARING THE REAR HOOD PANEL AND ATTACHING THE FUEL HOSES

STAGE COMPLETE



STAGE 94: ASSEMBLING THE SPOILERS AND ATTACHING THE REAR HOOD PANEL

94A Left spoiler (L)

94B Right spoiler (R)

94C Hood light

NP Screw 1.2 x 2.5 mm (x10)

IM Screw 1.7 x 3.5 mm (x5)

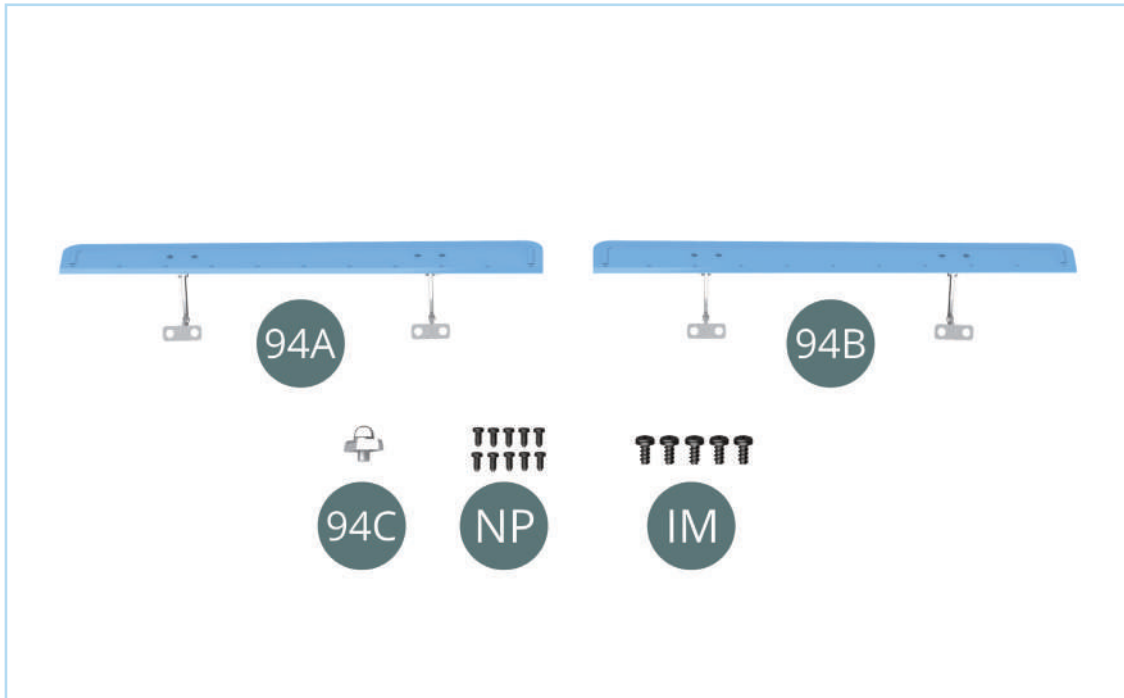

ASSEMBLY DIAGRAM

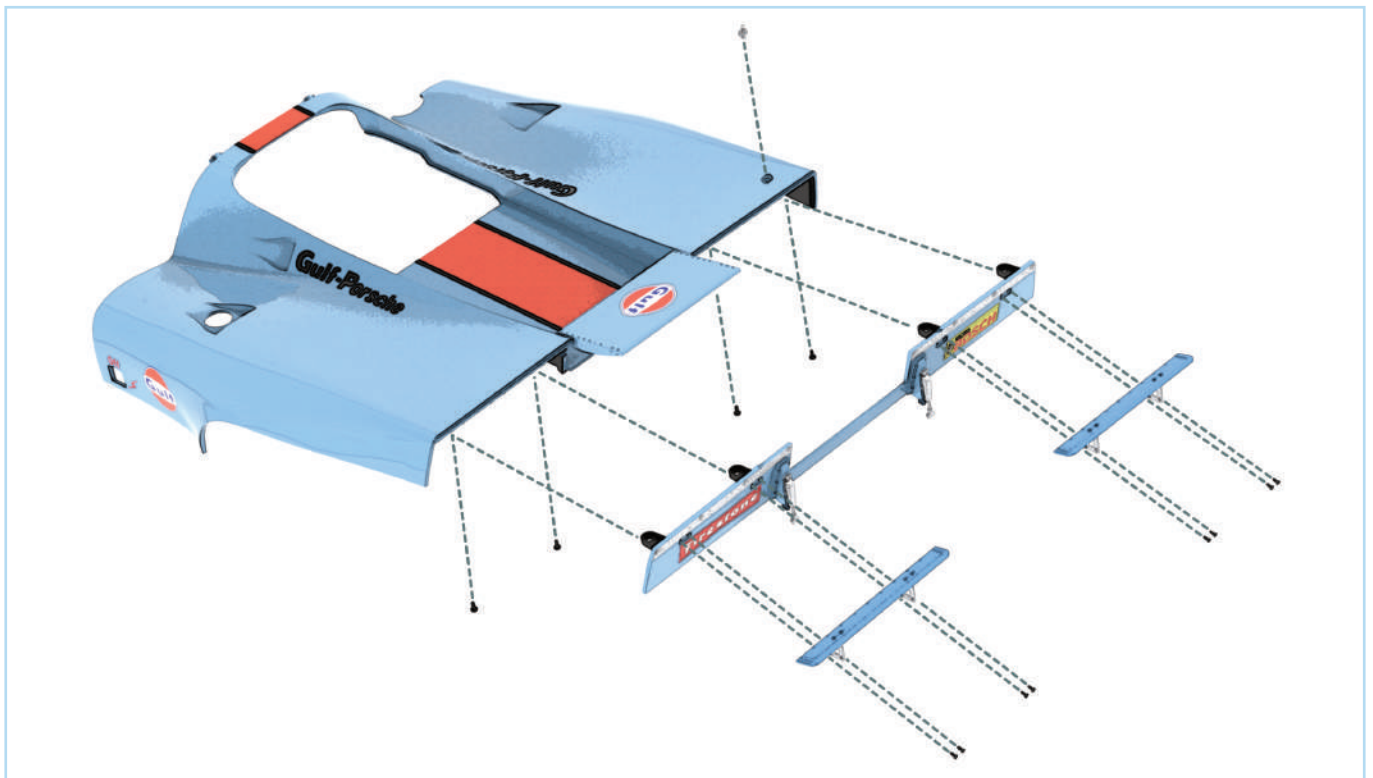

STAGE 94: ASSEMBLING THE SPOILERS AND ATTACHING THE REAR HOOD PANEL

STEP 1

Fit the **left spoiler (94A)**, marked with an 'L' (orange arrow), onto the **rear hood panel (93A)** and fasten it using four **NP** screws.

As the screws are close to the spoiler's brackets, use a thin screwdriver to drive them in.



Fit the **right spoiler (94B)**, marked with an 'R' (orange arrow), in the same way and secure with four **NP** screws.

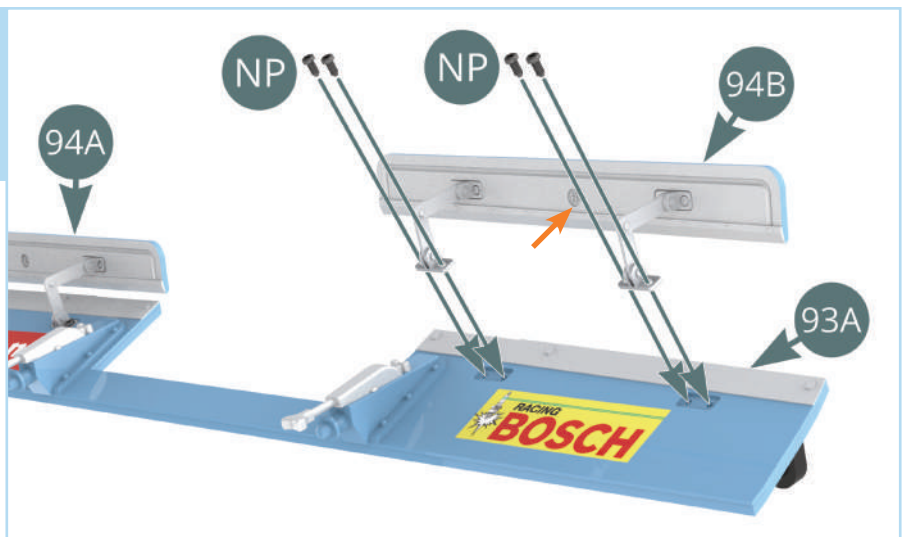

STEP 2

Align the **rear hood panel (93A)** with the **rear hood (90A)** then fit its tabs over the raised screw holes as shown. Secure the panel using four **IM** screws.

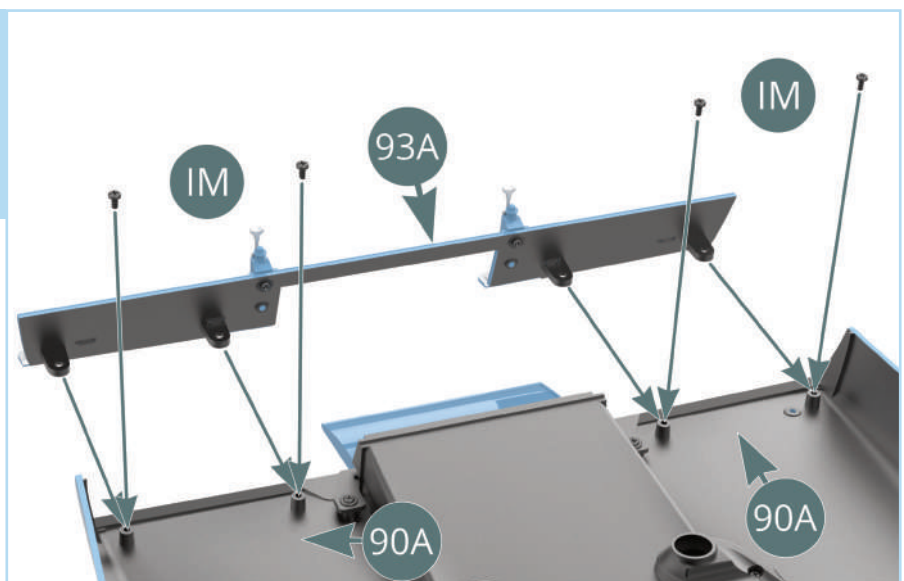

STAGE 94: ASSEMBLING THE SPOILERS AND ATTACHING THE REAR HOOD PANEL

Press the **hood light (94C)** into the shaped hole on the right side of the **rear hood (90A)**. Orient the light so that the glass is towards the front of the car as shown.

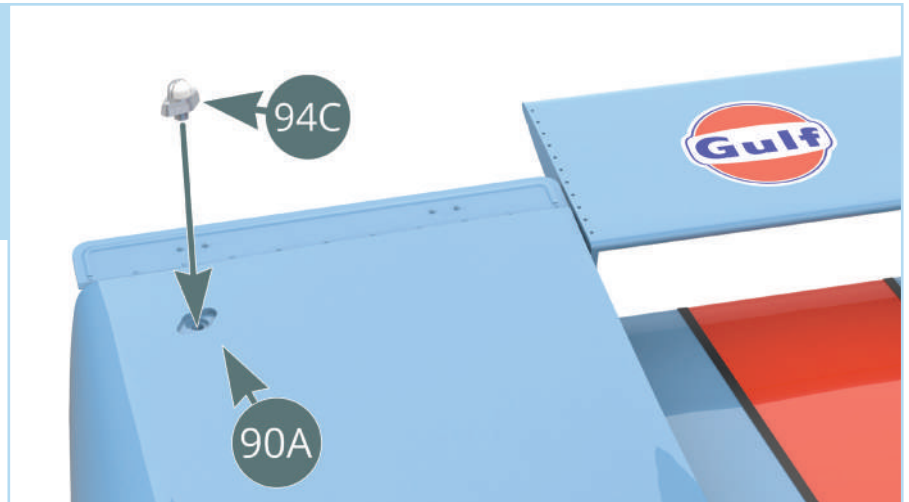

STAGE COMPLETE



STAGE 95: FITTING THE COCKPIT VENTILATION PIPES AND THE FRONT BODY

95A Left pipe half

95B Left pipe half

95C Right pipe half

95D Right pipe half

95E Right pipe half

95F Right pipe half

EP Screw 1.7 x 5 mm (x3)

IM Screw 1.7 x 3.5 mm (x3)

JM Screw 2.0 x 5 mm (x8)

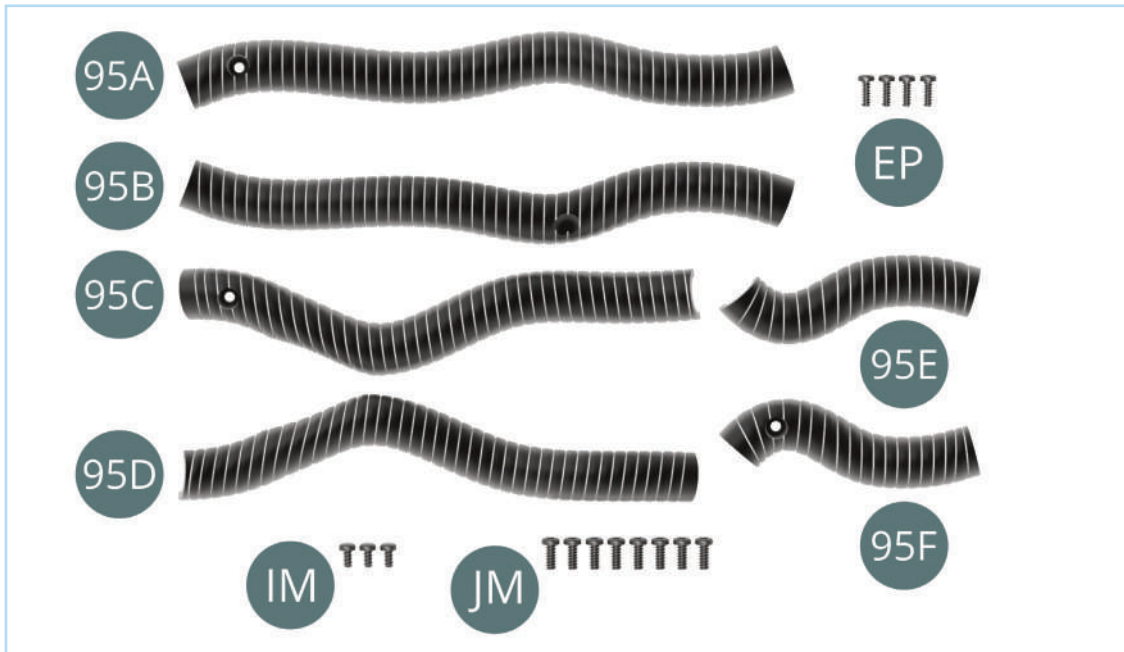

ASSEMBLY DIAGRAM

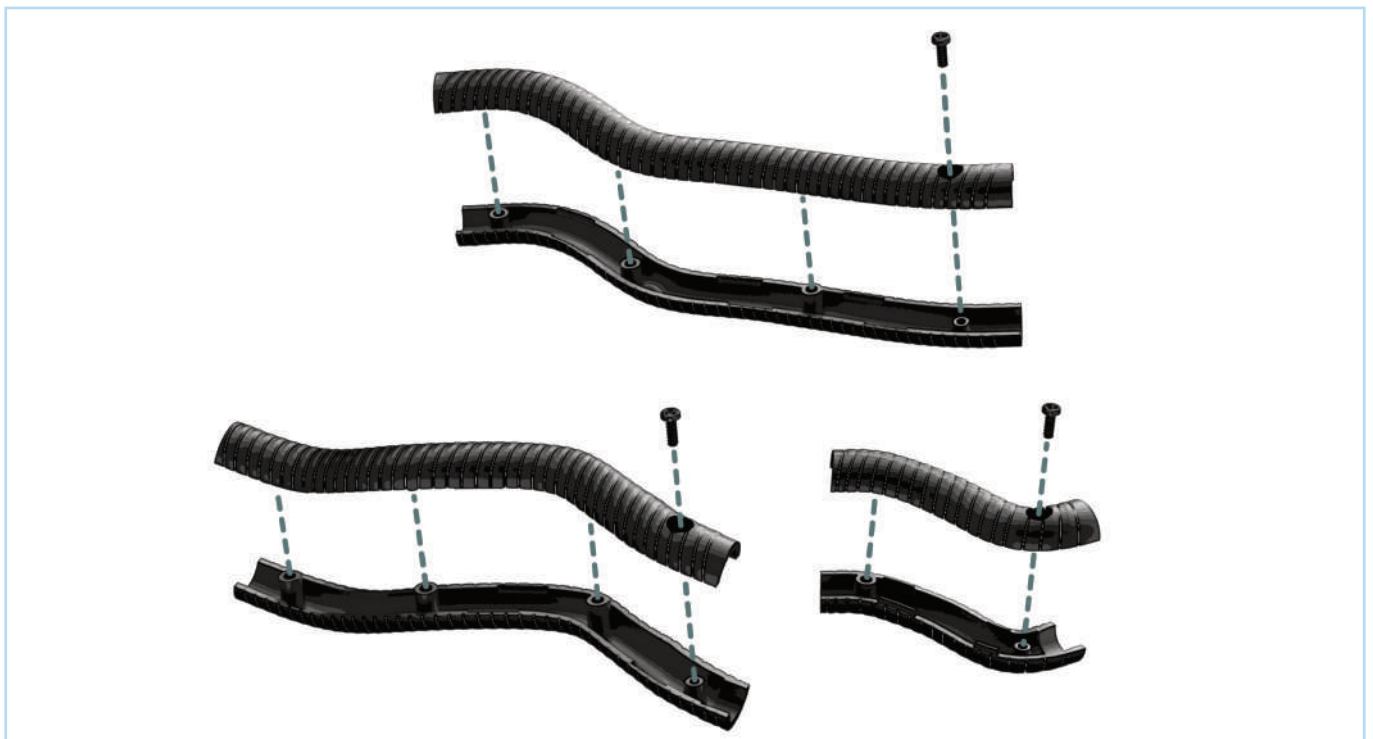

STAGE 95: FITTING THE COCKPIT VENTILATION PIPES AND THE FRONT BODY

ASSEMBLY DIAGRAM

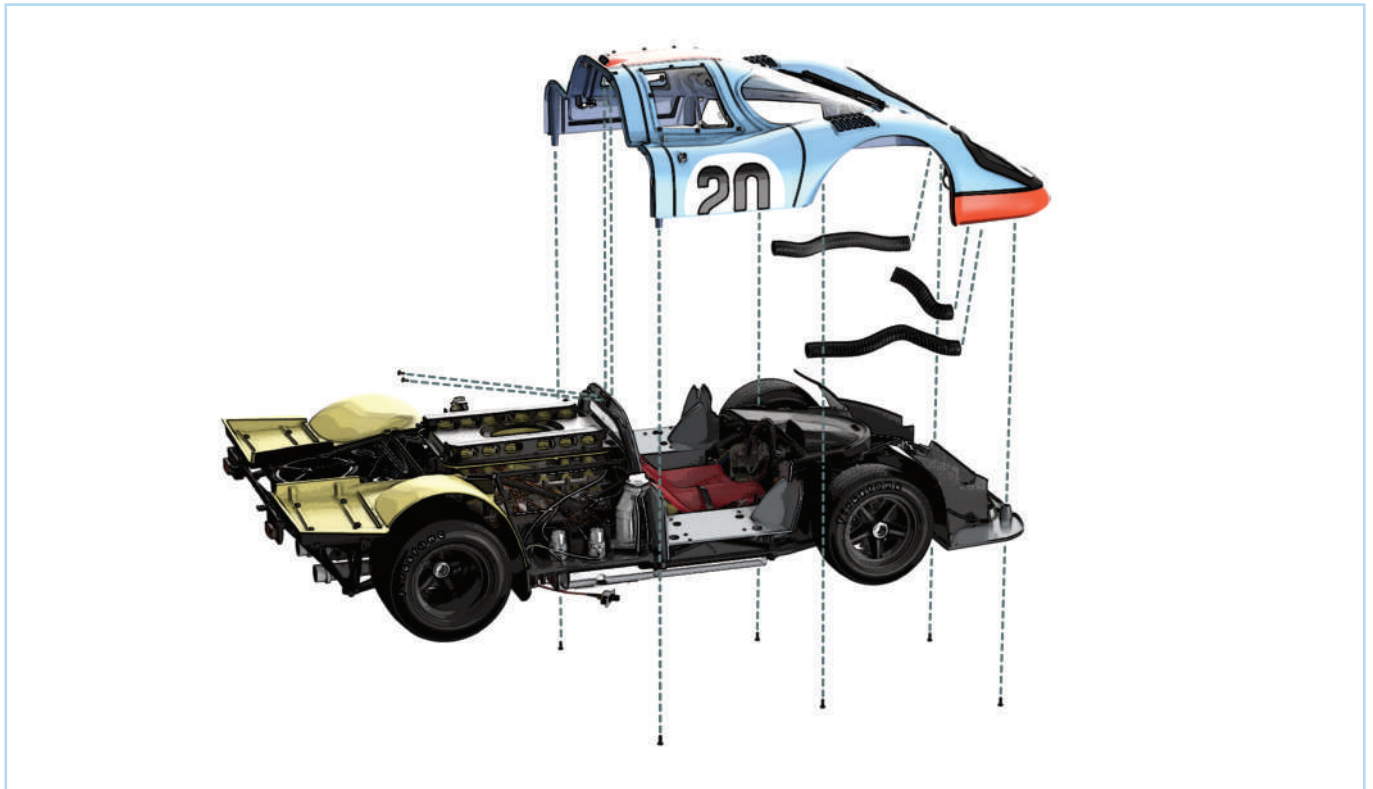

STEP 1

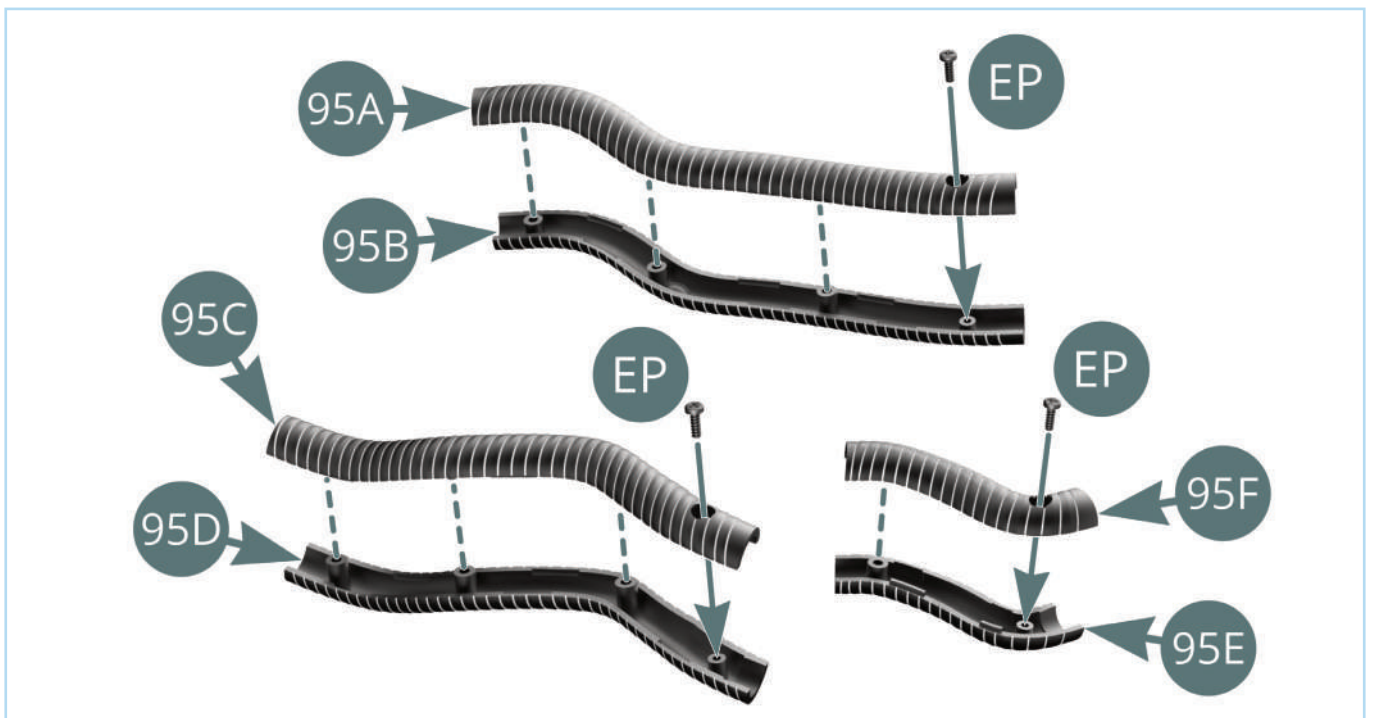

Fit the pipe halves together as shown: **95A and 95B**, **95C and 95D**, **95E and 95F**, then fix each pair using an **EP** screw.

STAGE 95: FITTING THE COCKPIT VENTILATION PIPES AND THE FRONT BODY

The pipes will be referred to by their combined part numbers: **left pipe (95AB)**, **right pipe (95CD)** and **right pipe (95EF)**.

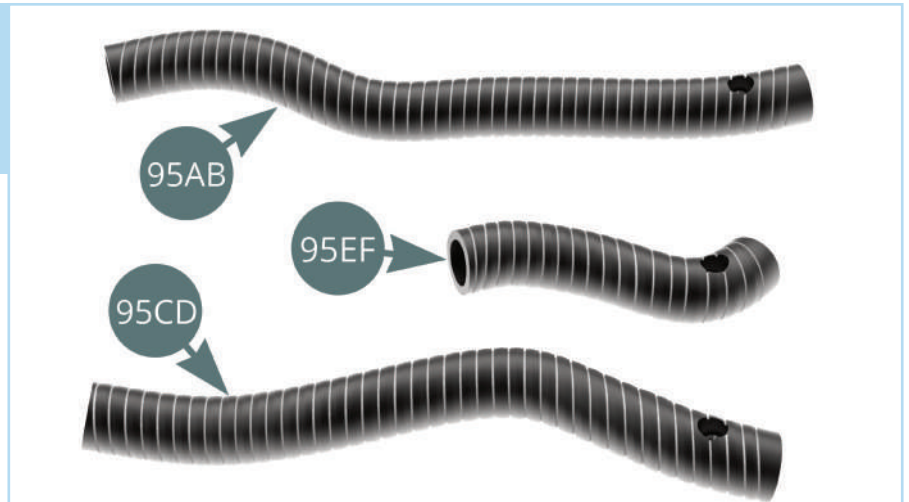

STEP 2

Attach the end with the screw of **right pipe (95CD)** to the **right air scoop (82C)** as shown.

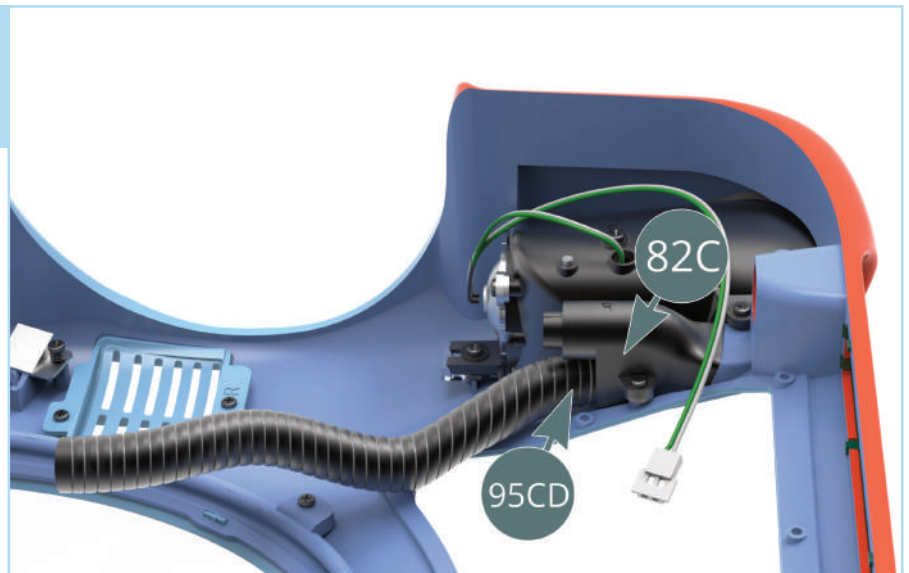

Move the **headlight LED cables (35F)** into the position shown in the image.

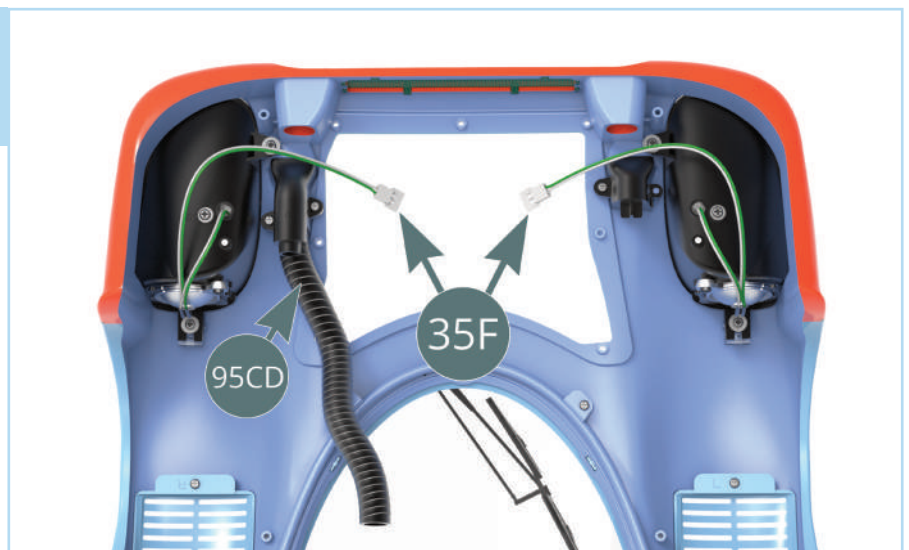

STAGE 95: FITTING THE COCKPIT VENTILATION PIPES AND THE FRONT BODY

STEP 3

At the front of the chassis assembly, move the **headlight LED cables (35F)** into the position shown in the image.

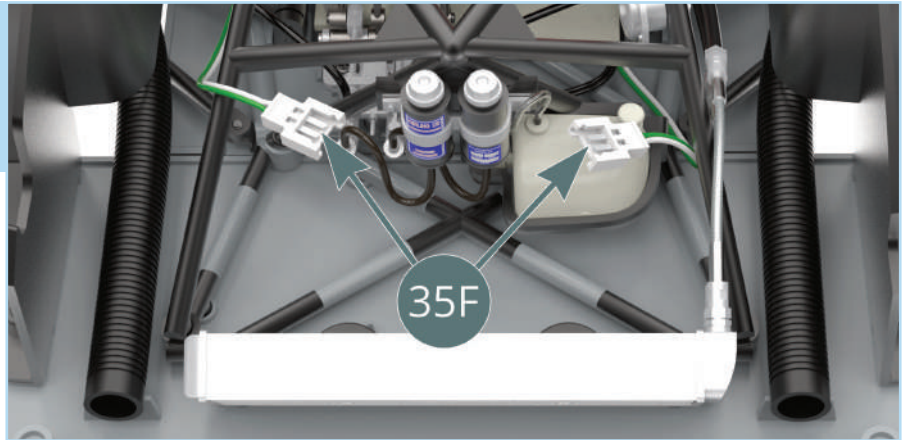

Now take the **front body (80A)** and align it with the **chassis (25A)** as shown. Fit the raised screw holes of the body into the corresponding screw holes on the assembly. The **right pipe (95CD)** will need to be guided through the framework while fitting the body (see image below). Ensure that the fuel filler neck aligns with the slot in the front body while fitting (orange arrow).

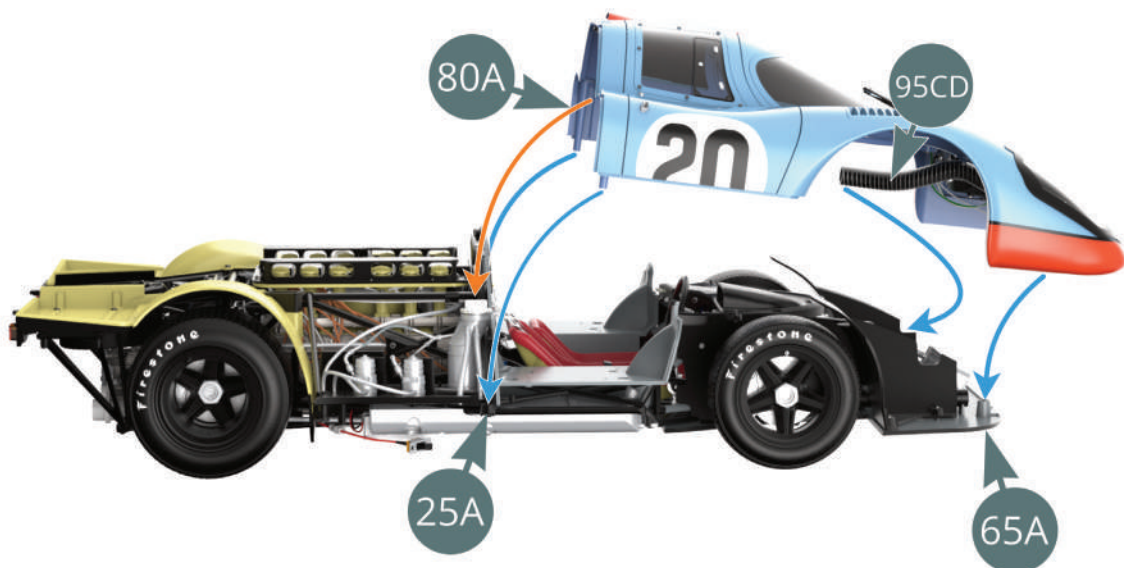

As you fit the front body, guide the **right pipe (95CD)** through the framework and underneath the dashboard.



STAGE 95: FITTING THE COCKPIT VENTILATION PIPES AND THE FRONT BODY

Once the body has been fitted, connect the two ends of the **headlight LED cables (35F)** as shown by the blue arrows. After they are connected, tuck them away from view at the sides (red arrows).

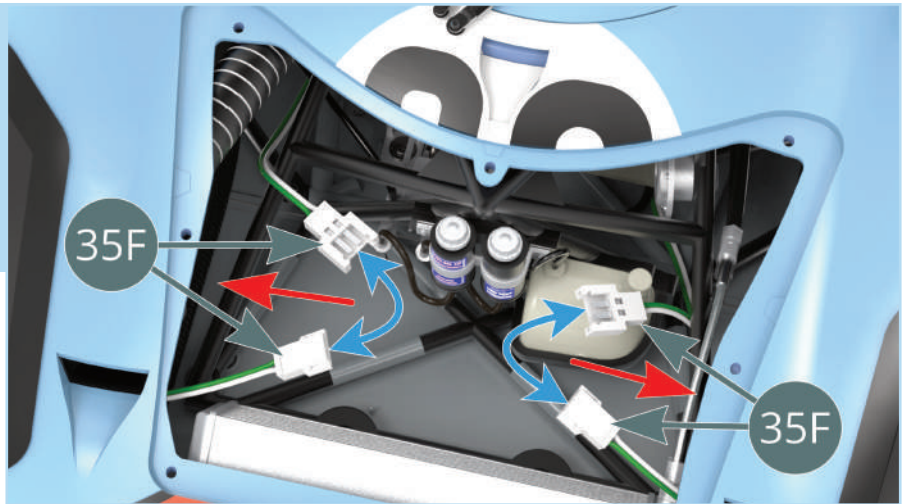

STEP 5

Take **right pipe (95EF)** and fit the end with the screw to the **right air scoop (82C)** as shown.

You can use a pair of tweezers to apply pressure on the end of the pipe to push it into place (orange arrow).

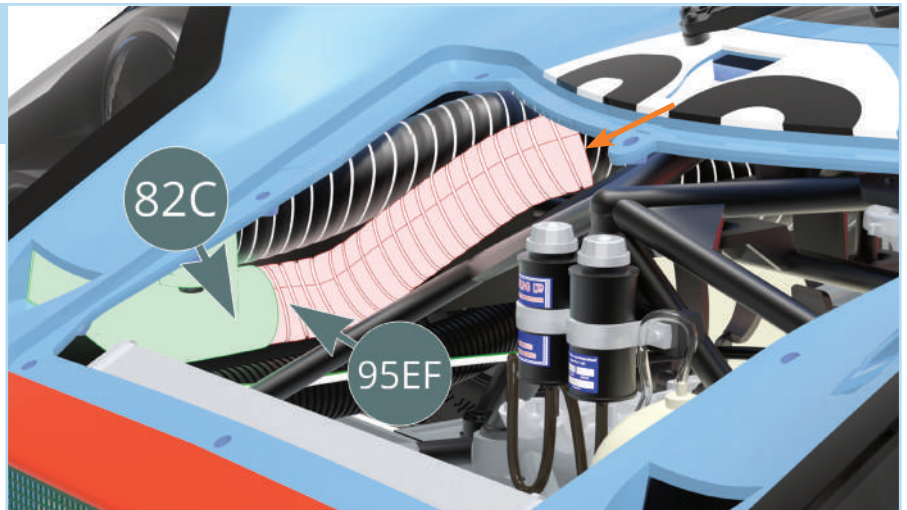

Open the left door and pass the **left pipe (95AB)** through the framework (red arrow) towards the front and into the position shown in the image.

You can push the end of the pipe from under the dashboard using your finger or tweezers to fit it in place.



STAGE 95: FITTING THE COCKPIT VENTILATION PIPES AND THE FRONT BODY

Fit the screw end of the **left pipe (95AB)** to the **left air scoop (82B)** using tweezers.

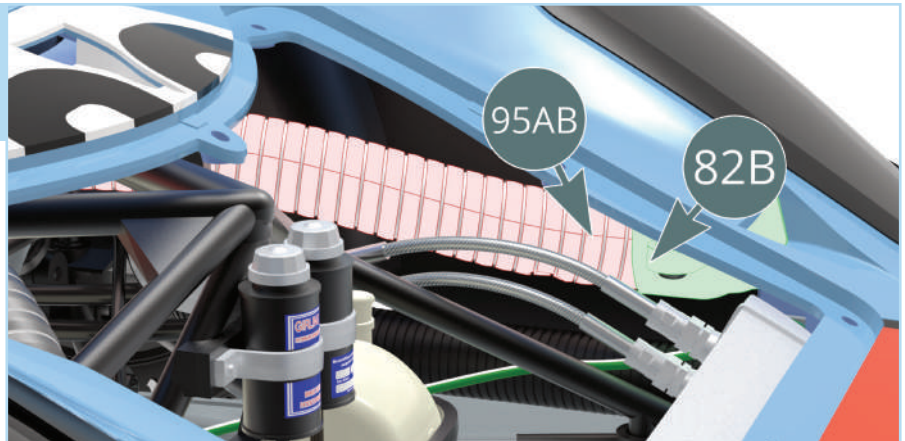

STEP 6

Fix the front body to the **front floor panel (65A)**, the **chassis (25A)** and the **left and right mudguards (35A and 35B)** using six **JM** screws (circled in red). Check the connection points at the rear (orange arrows) are seated correctly and that the screws are tightened fully so that the front body sits flush.

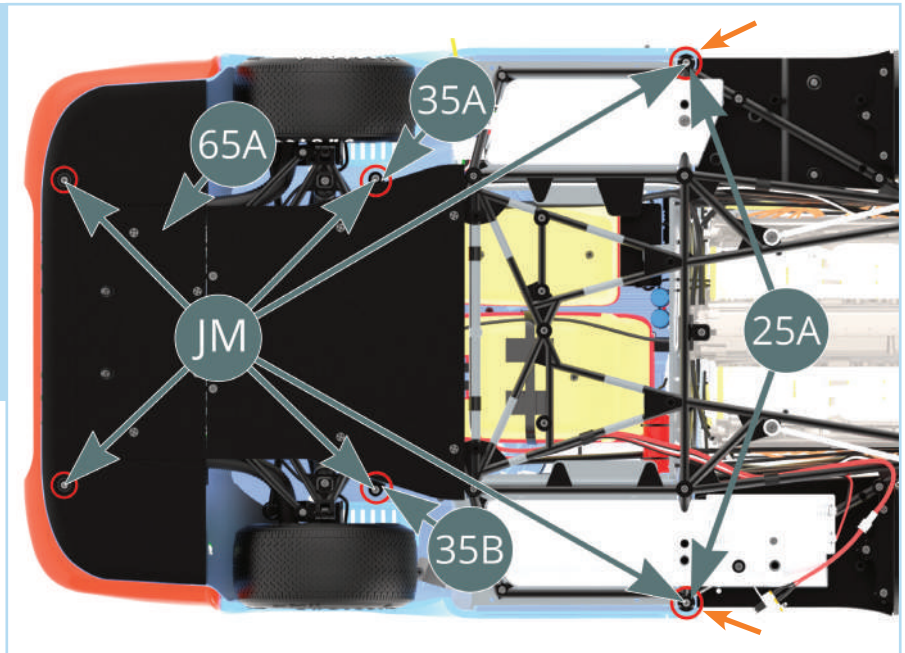

The **top roll cage (84A)** has two screw holes which align with the holes in the **cockpit partition frame (37A)**. Check the holes are aligned correctly. Adjust the fit of the front body if necessary until the holes have aligned.

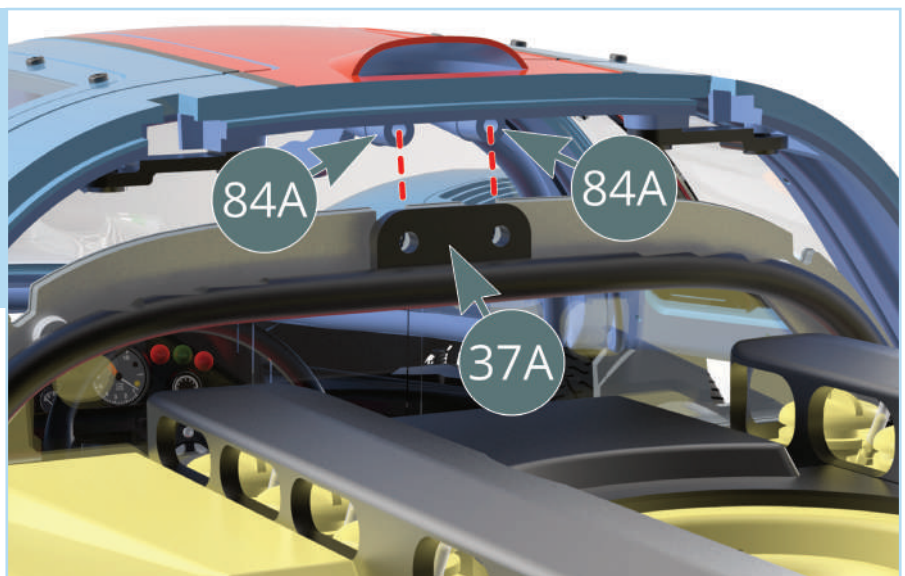

STAGE 95: FITTING THE COCKPIT VENTILATION PIPES AND THE FRONT BODY

Secure the top roll cage to the **cockpit partition frame (37A)** using two **IM** screws.

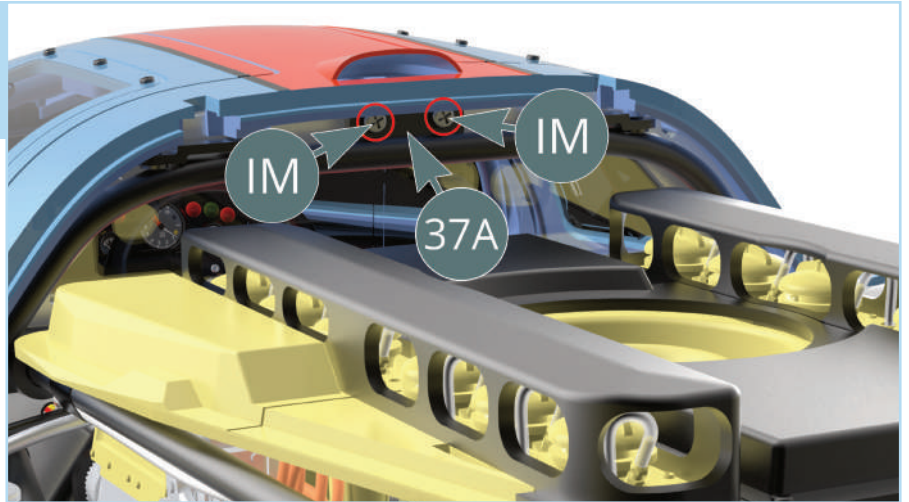

STAGE COMPLETE

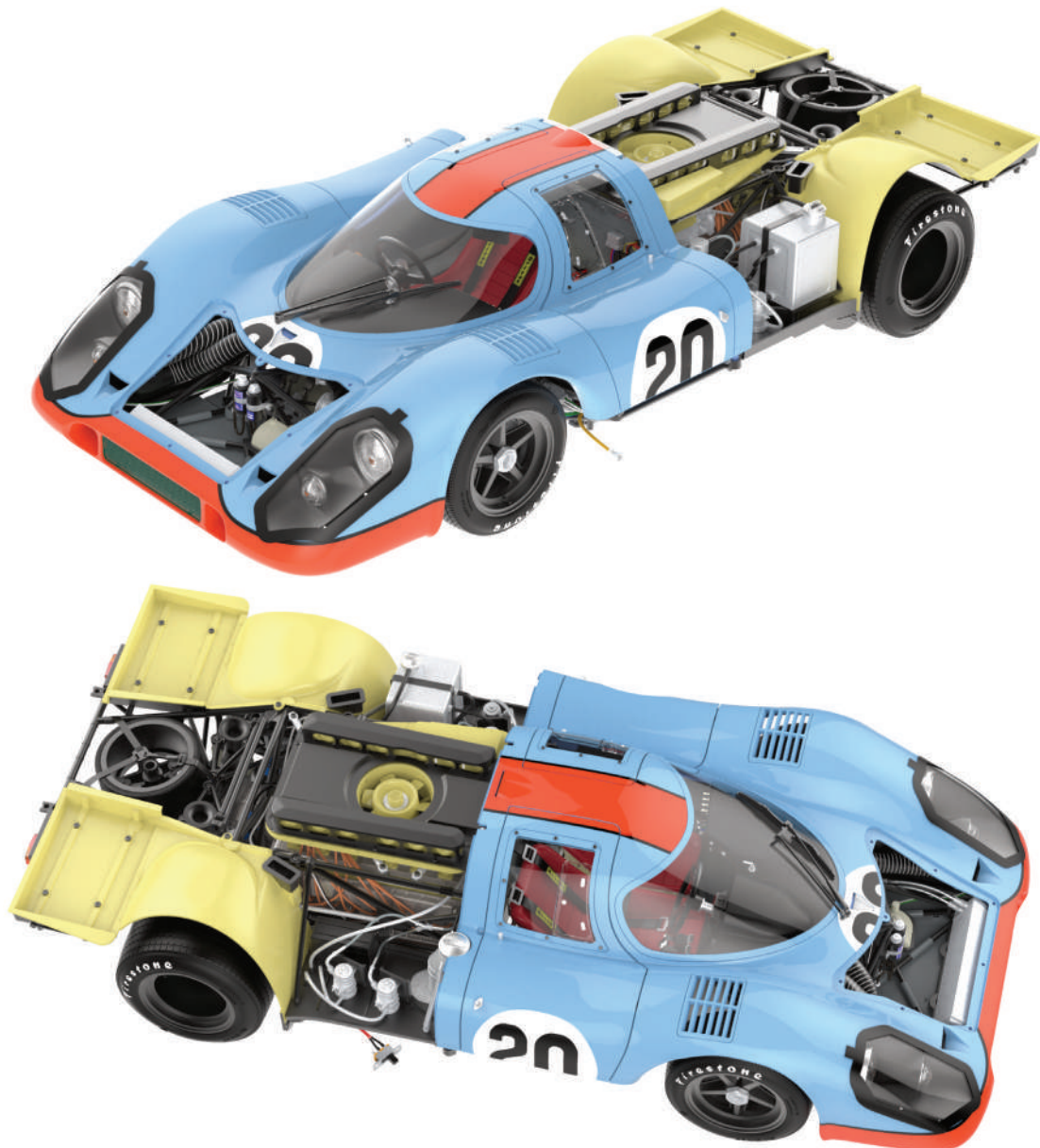

STAGE 96: ASSEMBLING AND ATTACHING THE LEFT SIDE FAIRING

96A Left side fairing

96B Upper bracket

96C Bracket 1 (x2)

96D Bracket 2

96E Bracket 3

96F Front plate

IM Screw 1.7 x 3.5 mm (x14)

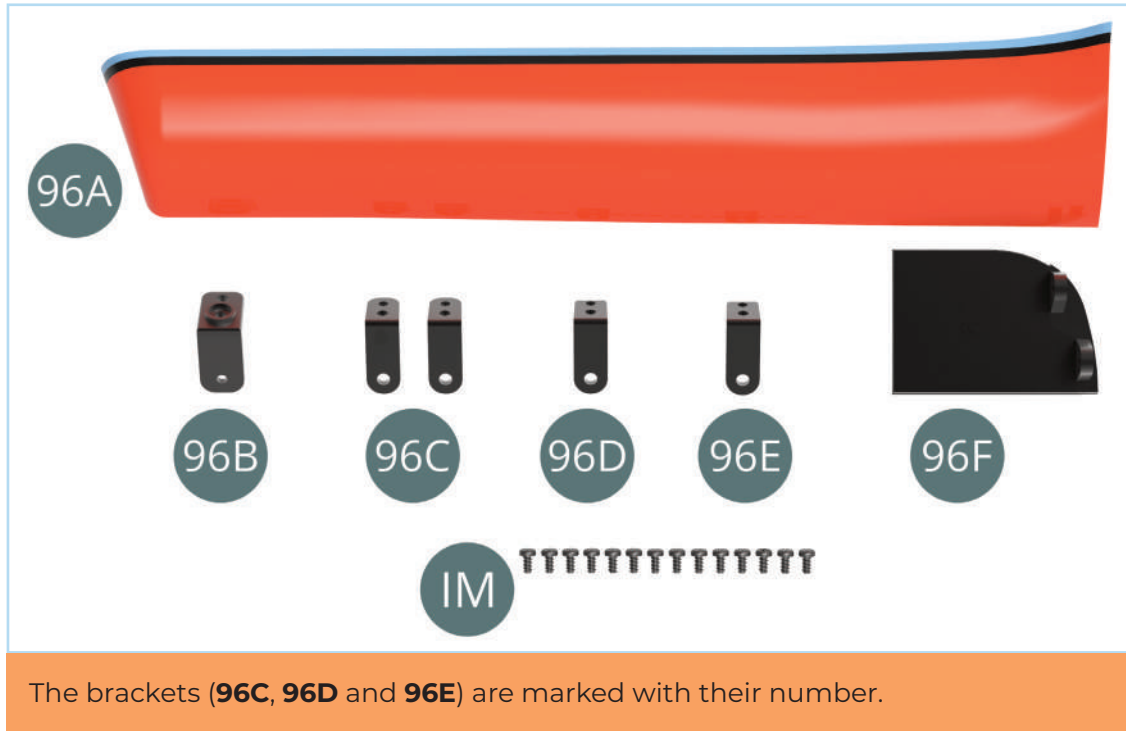

ASSEMBLY DIAGRAM

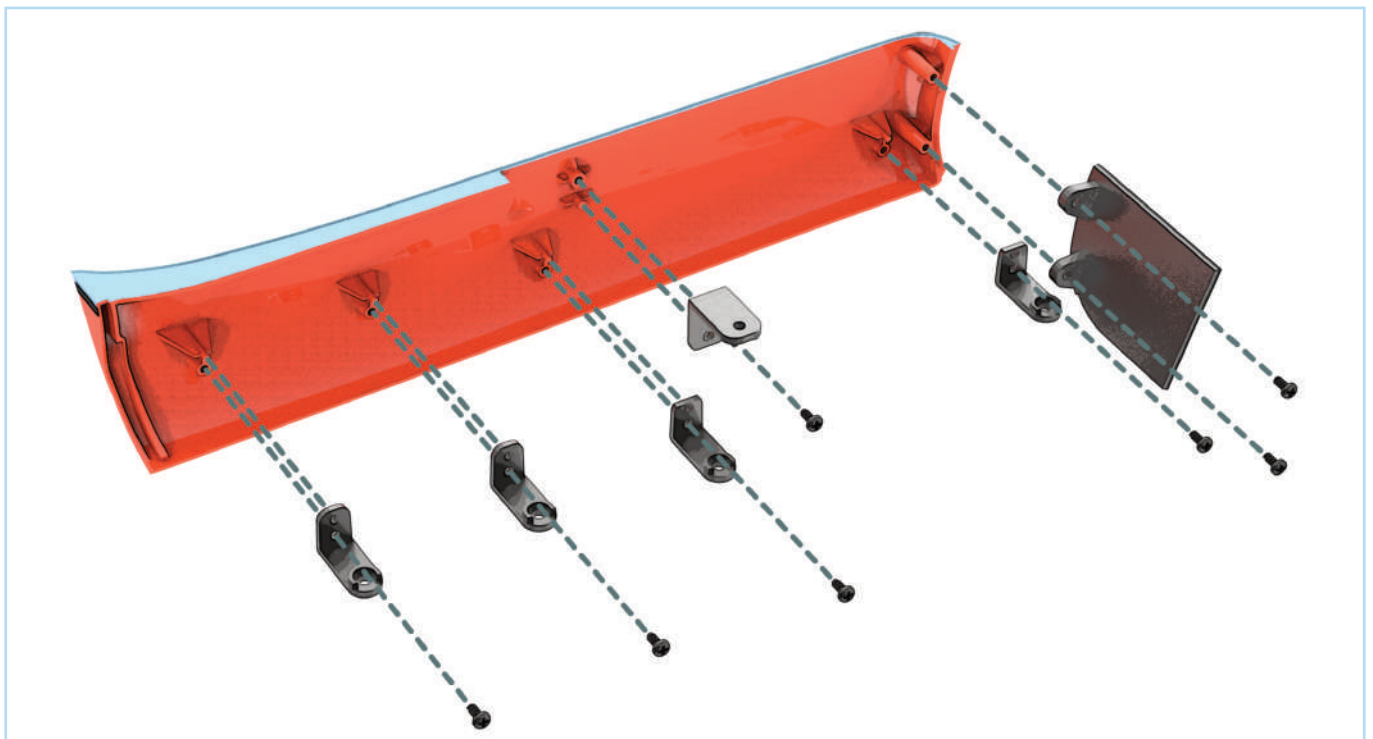

STAGE 96: ASSEMBLING AND ATTACHING THE LEFT SIDE FAIRING

ASSEMBLY DIAGRAM

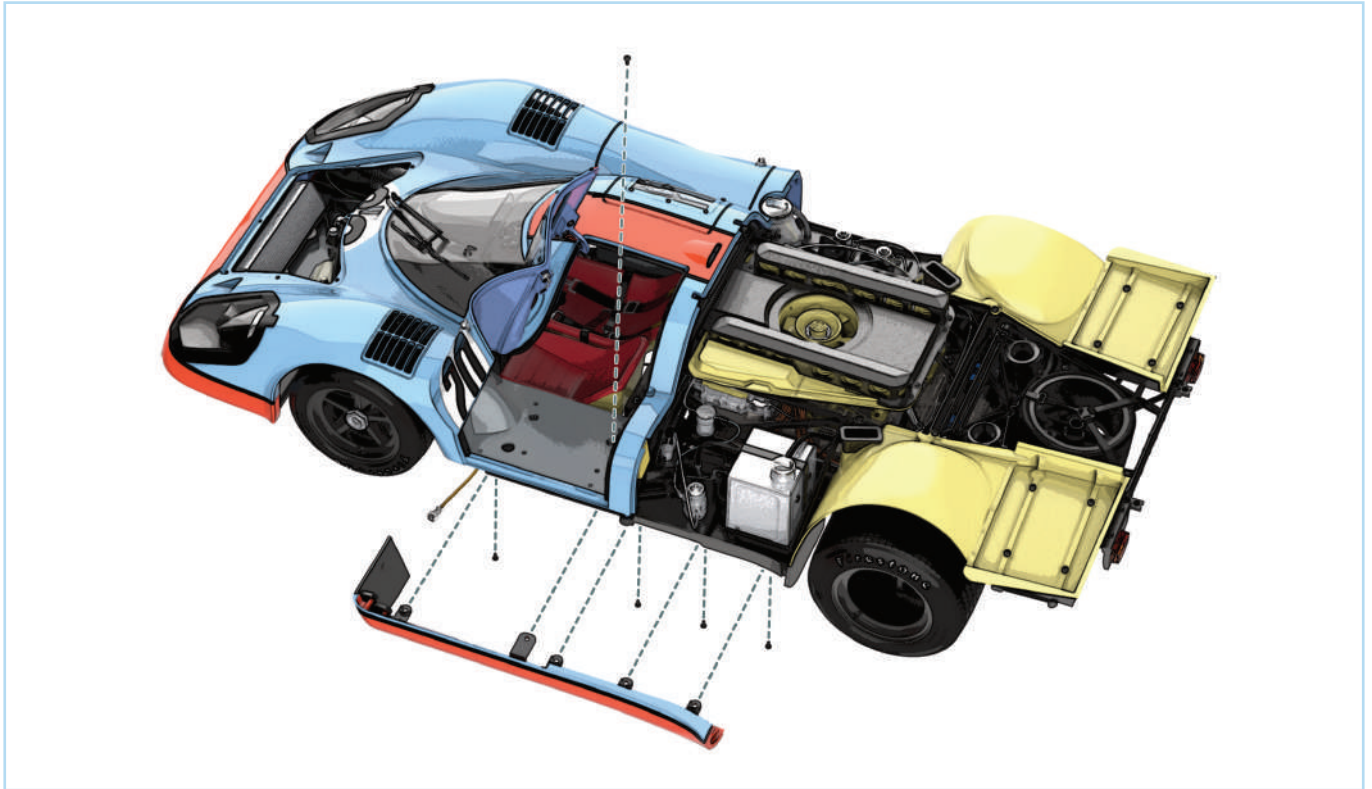

STEP 1

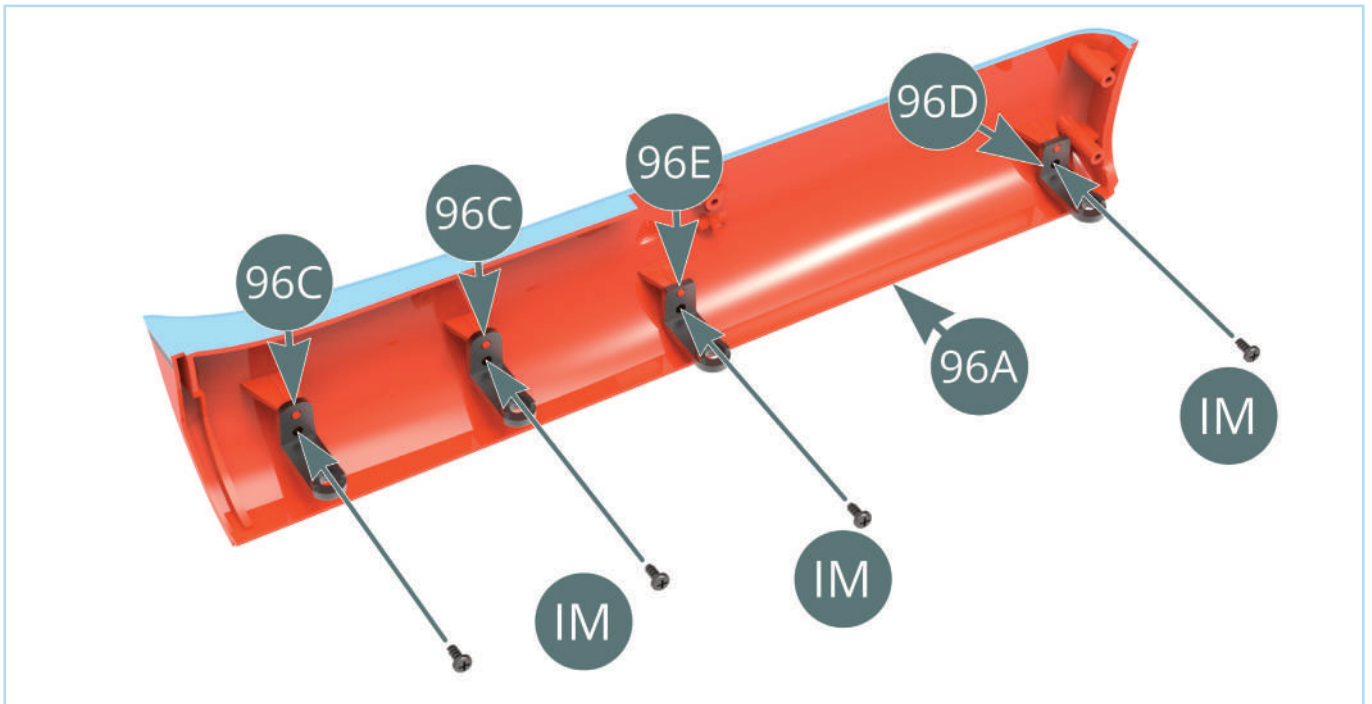

Position **bracket 2 (96D)**, **bracket 3 (96E)** and both **brackets 1 (96C)** on the **left side fairing (96A)** as shown. Fasten each bracket using an IM screw, tightening fully to secure the brackets.

STAGE 96: ASSEMBLING AND ATTACHING THE LEFT SIDE FAIRING

Position the **upper bracket (96B)** and the **front plate (96F)** on the **left side fairing (96A)** as shown, then fasten using three **IM** screws.

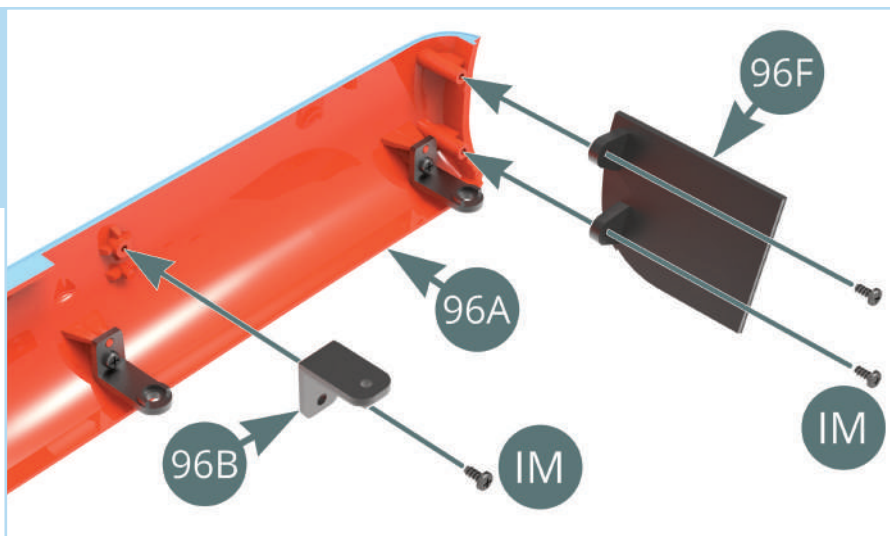

STEP 2

Fit the **left side fairing (96A)** onto the **chassis (25A)** and the **left chassis plate (69A)**. As indicated by the red arrow, hide the cables under the **front plate (96F)** while leaving the yellow cable coming out (see next image).



Start to secure the **left side fairing (96A)** by driving four **IM** screws through the **brackets (96C, 96D and 96E)** (highlighted green). Check the side fairing is flush with the front body and adjust the screws and brackets if needed.

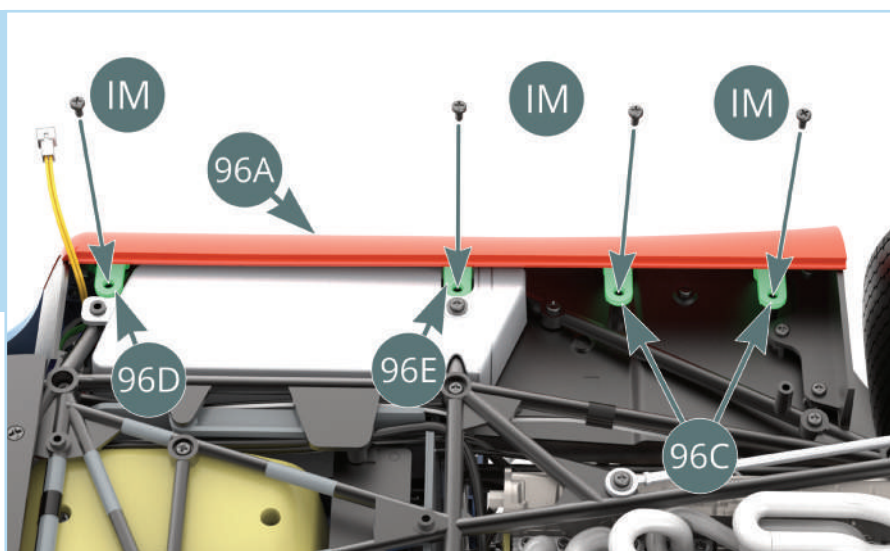

STAGE 96: ASSEMBLING AND ATTACHING THE LEFT SIDE FAIRING

STEP 6

Carefully turn the assembly over and open the left door. Use an **IM** screw to finish securing the **left side fairing (96A)** by driving it through the **left cockpit housing (68A)**.

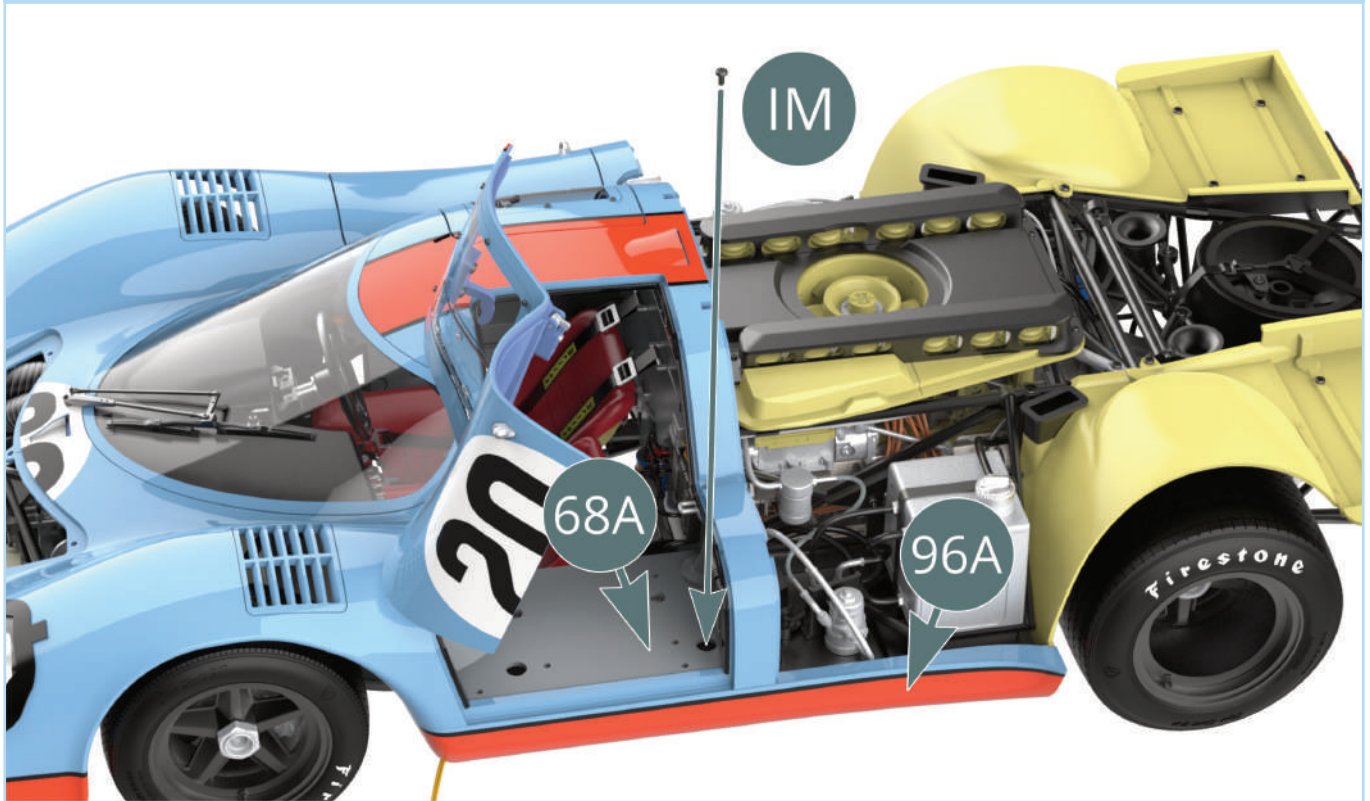

With the left side fairing secure, turn the assembly over once more and remove the **CM** screw from the **chassis (25A)**.

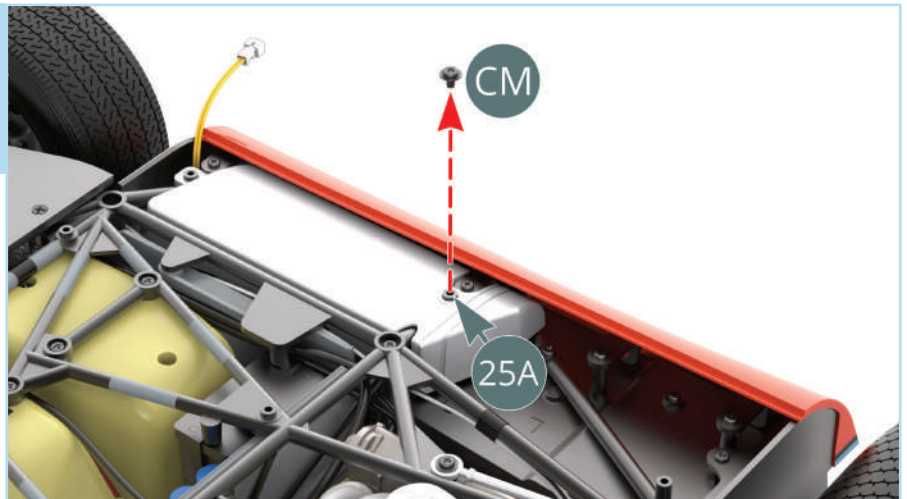

STAGE 96: ASSEMBLING AND ATTACHING THE LEFT SIDE FAIRING

STAGE COMPLETE

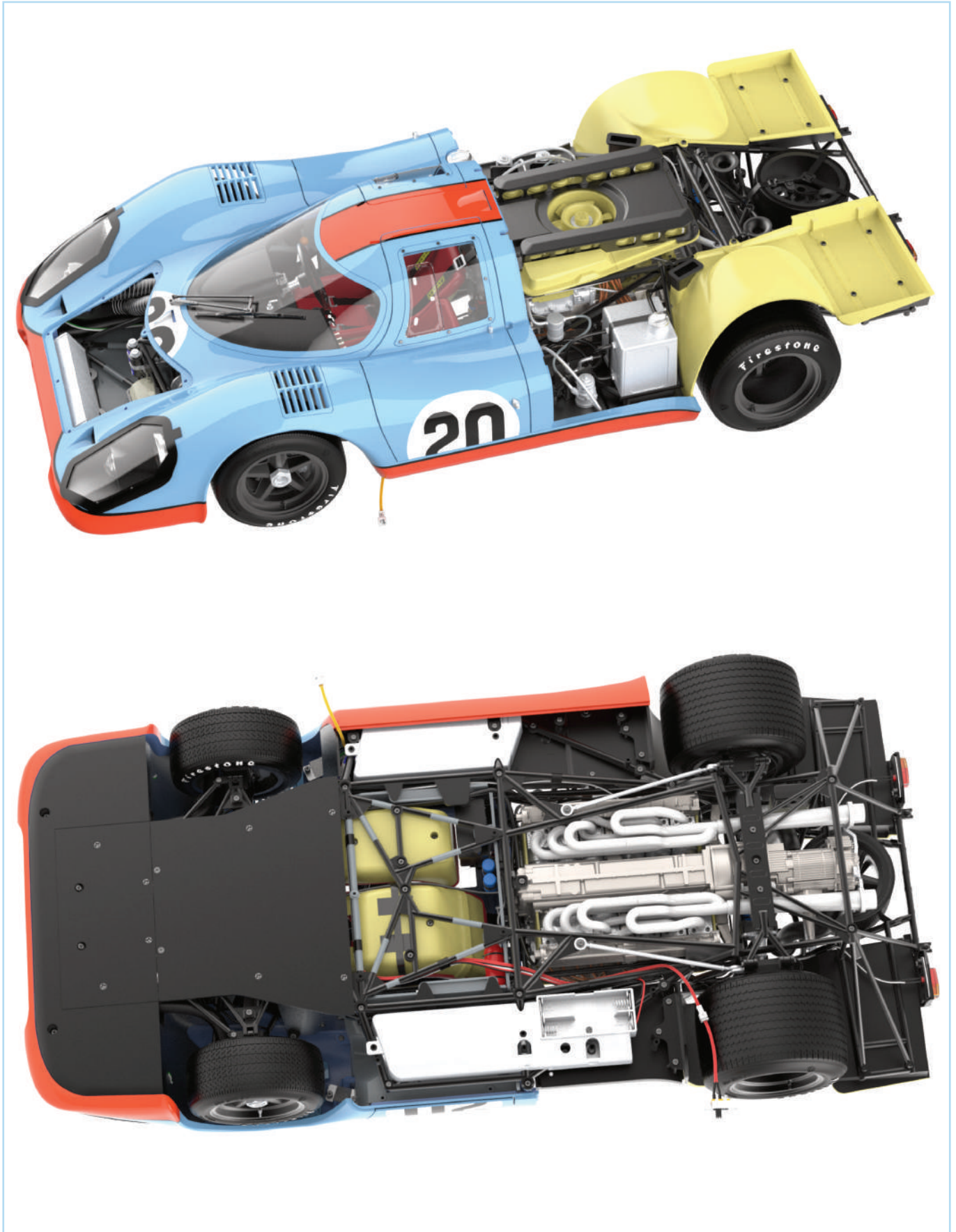

STAGE 97: ASSEMBLING AND ATTACHING THE RIGHT SIDE FAIRING

97A Right side fairing

97B Upper bracket

97C Bracket 1 (x2)

97D Bracket 2

97E Bracket 3

97F Front plate

IM Screw 1.7 x 3.5 mm (x14)

SM Screw 1.7 x 3.5 mm (x3)

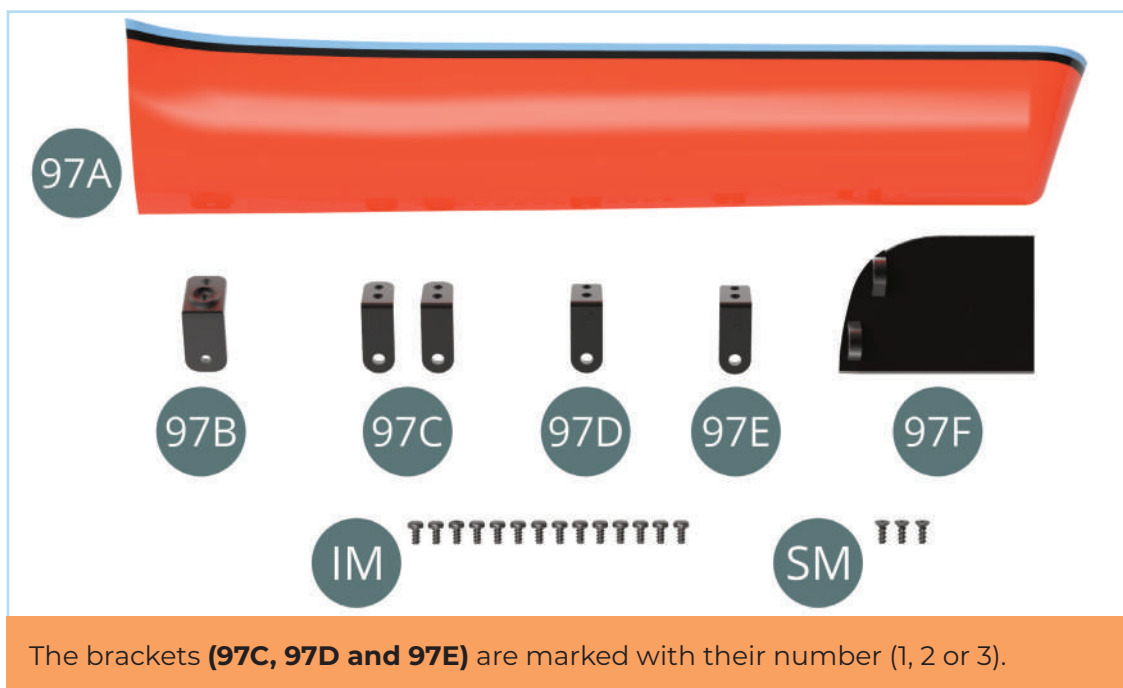

ASSEMBLY DIAGRAM

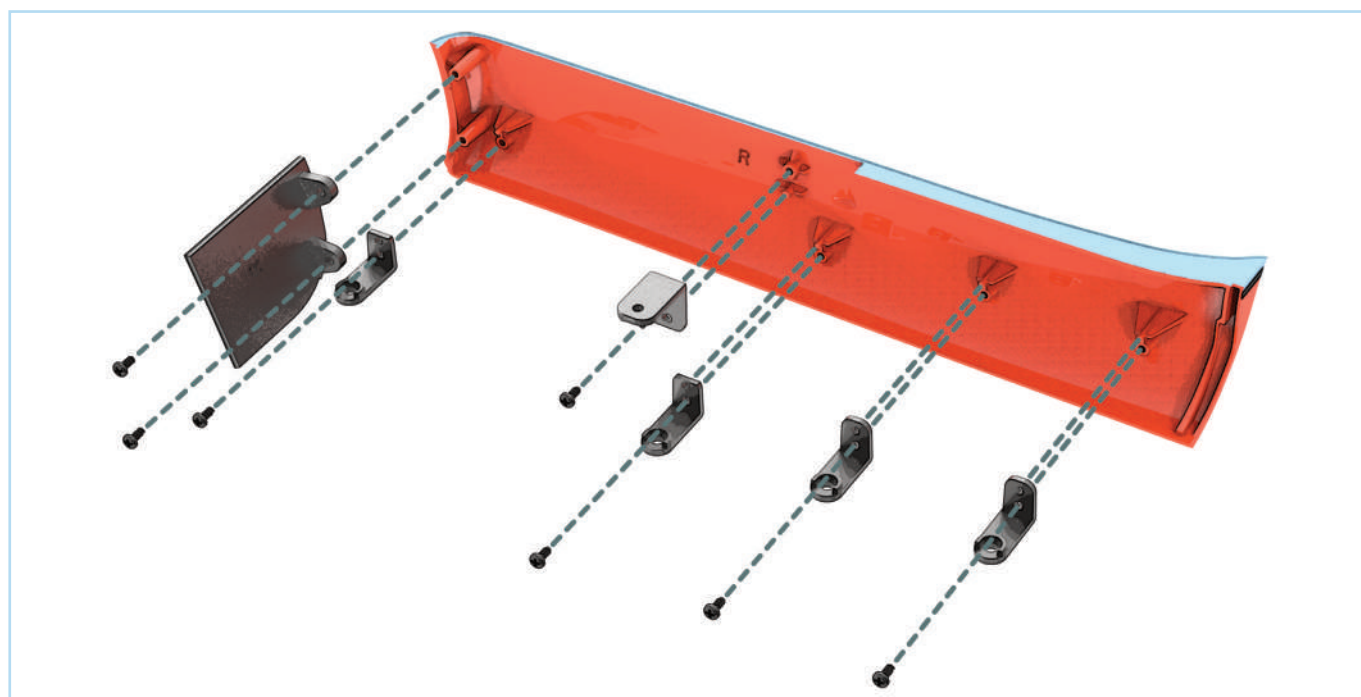

STAGE 97: ASSEMBLING AND ATTACHING THE RIGHT SIDE FAIRING

ASSEMBLY DIAGRAM

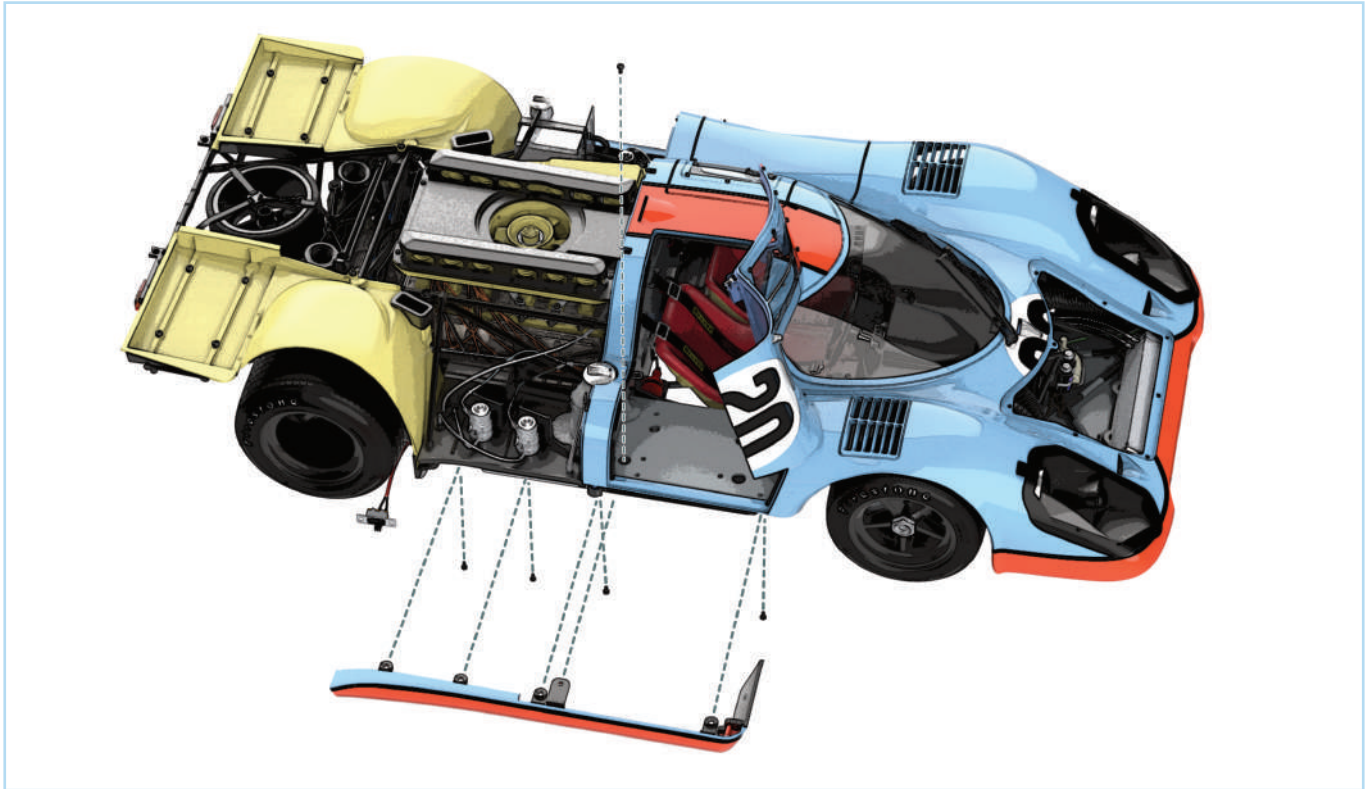

STEP 1

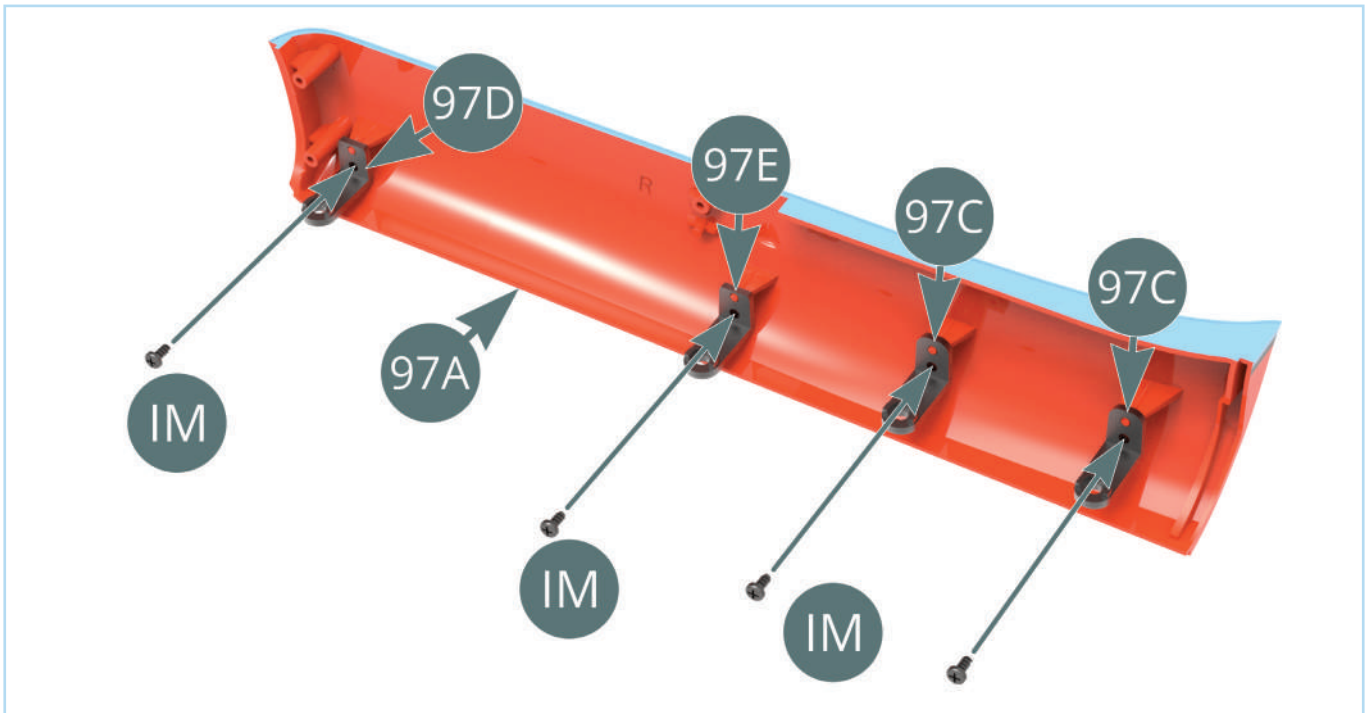

Position **bracket 2 (97D)**, **bracket 3 (97E)** and both **brackets 1 (97C)** on the **right side fairing (97A)** as shown. Fasten each bracket using an IM screw, tightening fully to secure the brackets.

STAGE 97: ASSEMBLING AND ATTACHING THE RIGHT SIDE FAIRING

Position the **upper bracket (97B)** and the **front plate (97F)** on the **right side fairing (97A)** as shown, then fasten using three **IM** screws.

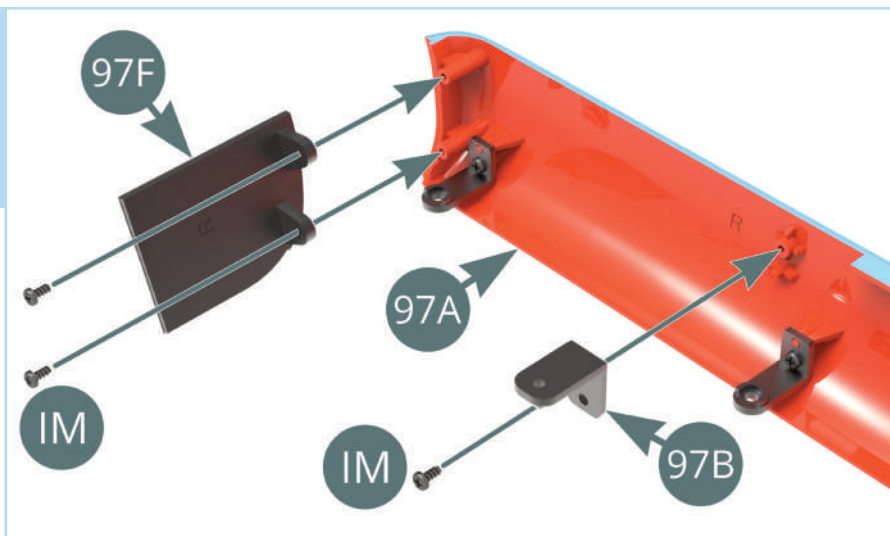

STEP 2

Fit the **right side fairing (97A)** onto the **chassis (25A)** and the **right chassis plate (73A)**.

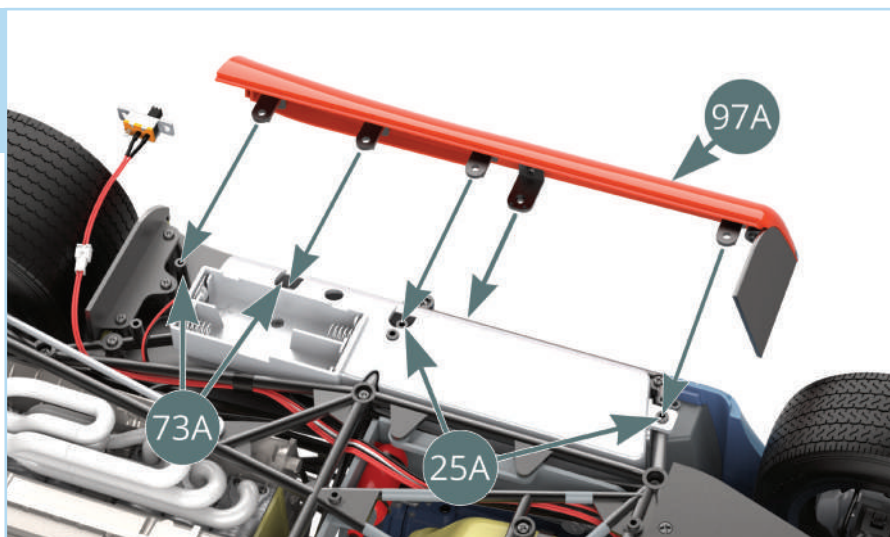

Start to secure the **right side fairing (97A)** by driving four **IM** screws through the **brackets (97C, 97D and 97E)** (highlighted green). Check the side fairing is flush with the front body and adjust the screws and brackets if needed.

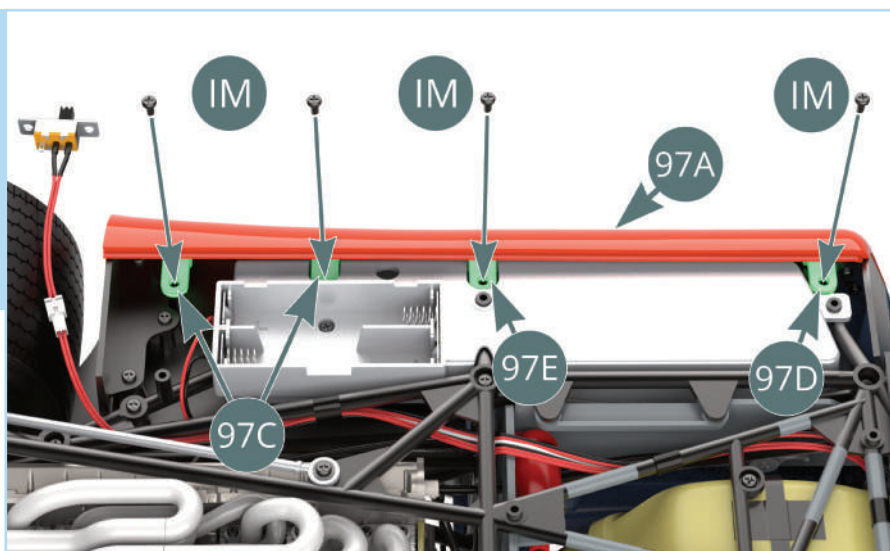

STAGE 97: ASSEMBLING AND ATTACHING THE RIGHT SIDE FAIRING

STEP 3

Carefully turn the assembly over and open the right door. Use an **IM** screw to finish securing the **right side fairing (97A)** by driving it through the **right cockpit housing (68B)**.

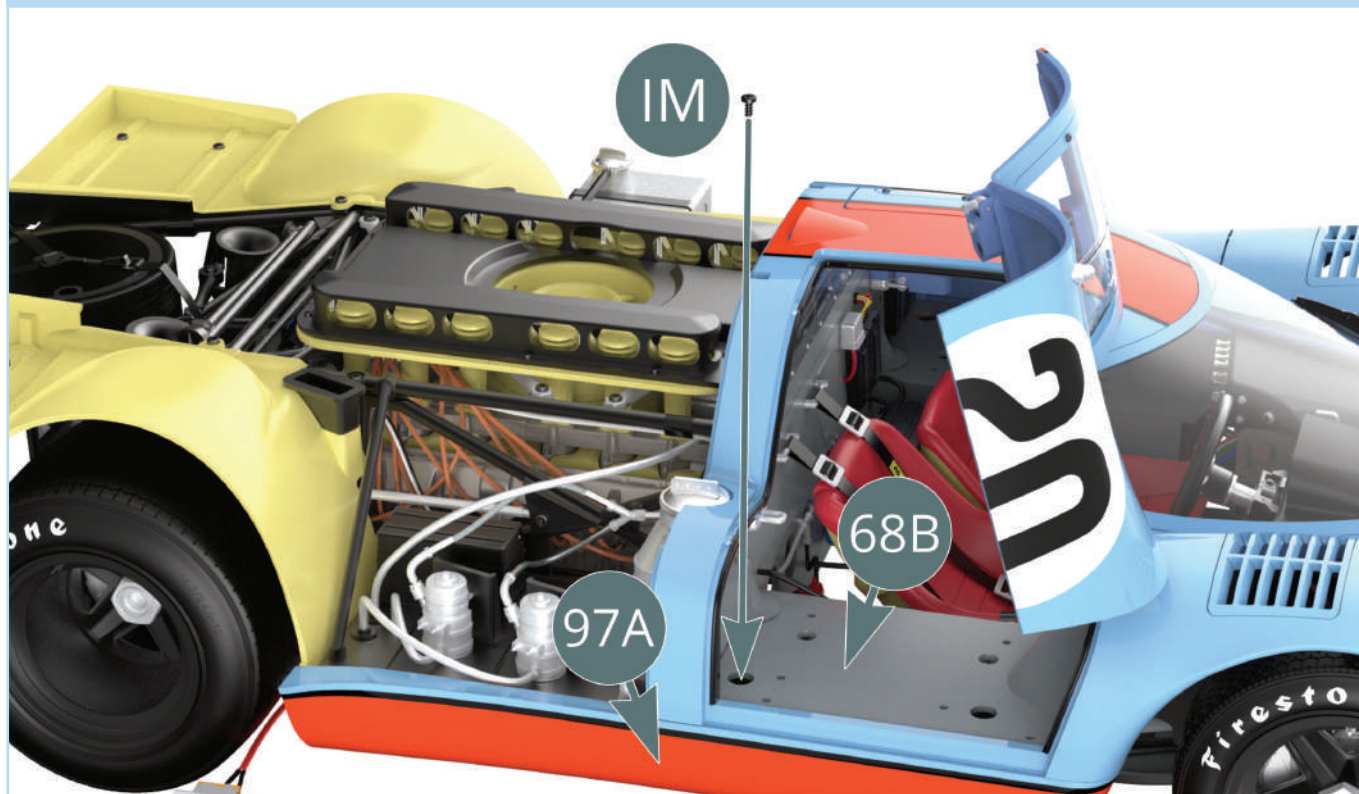

Remove the two **IM** screws at the rear of the model as shown by the red arrows, then replace them with the newly supplied **SM** screws.

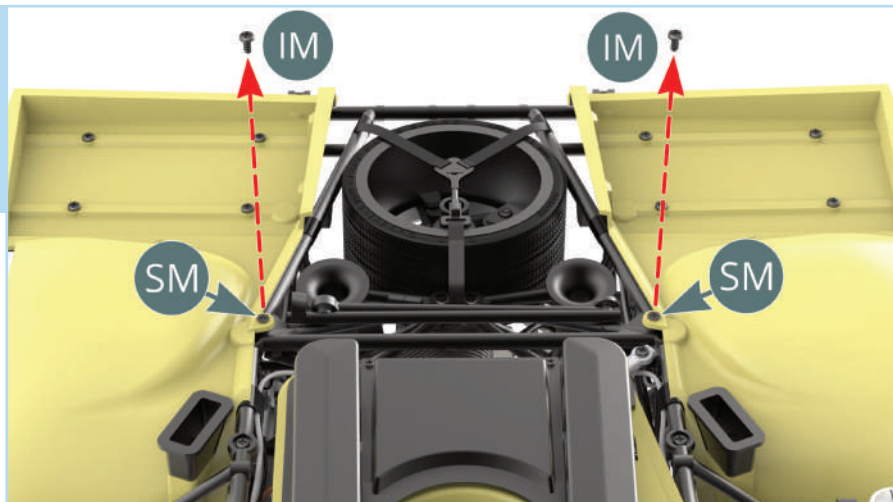

At this point, you may wish to connect the **speaker (34C)**. Insert two AAA batteries, then push the switch to the 'ON' position and test the electric functions of your model. Open the left door and press the three switches, along with the brake pedal, to test the lights and sounds. If there are any issues, remove the two side fairings and carefully check none of the wires have become disconnected or trapped.

STAGE 97: ASSEMBLING AND ATTACHING THE RIGHT SIDE FAIRING

STAGE COMPLETE

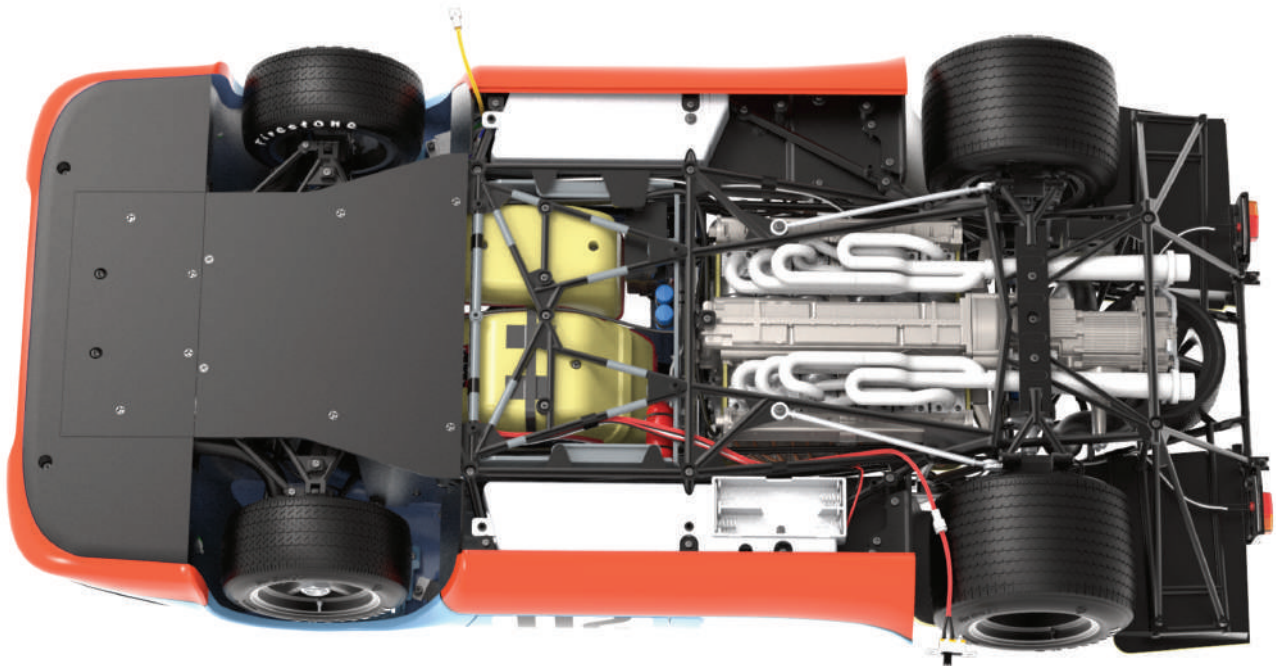
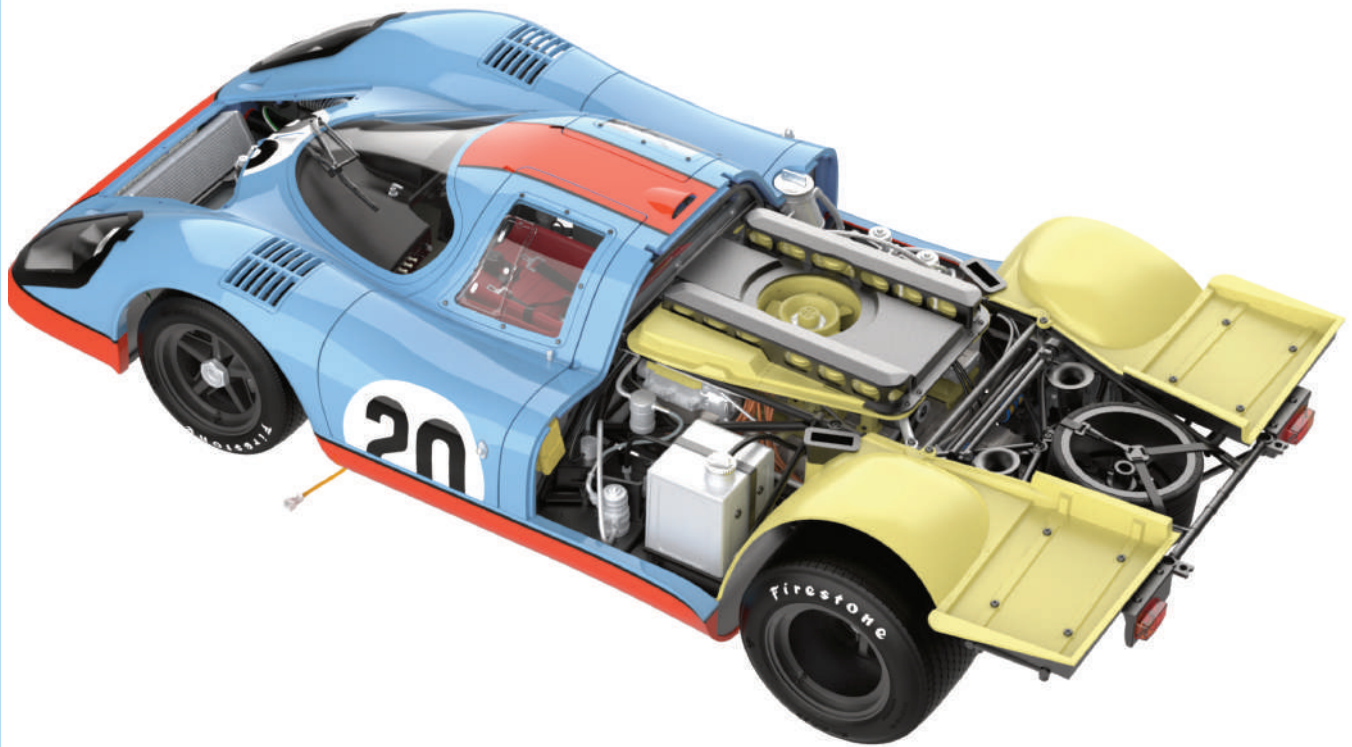

STAGE 98: ADDING THE DOOR SILLS AND TRIMS

98A Left door sill

98B Right door sill

98C Left door trim (flat)

98D Right door trim (rounded)

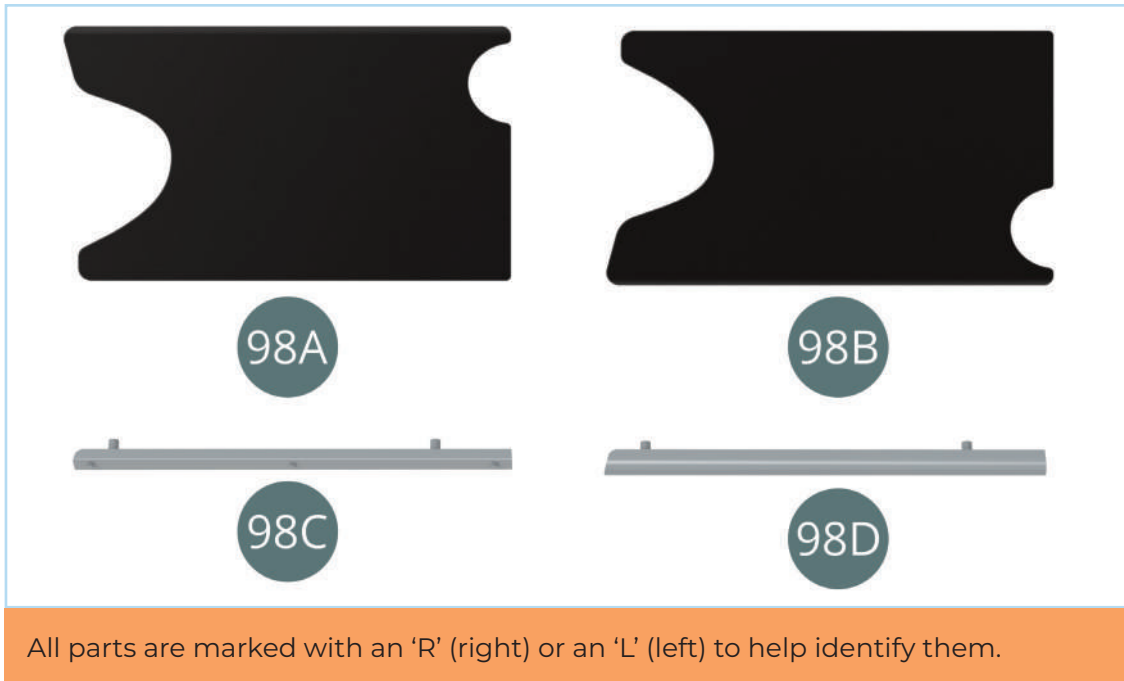

ASSEMBLY DIAGRAM

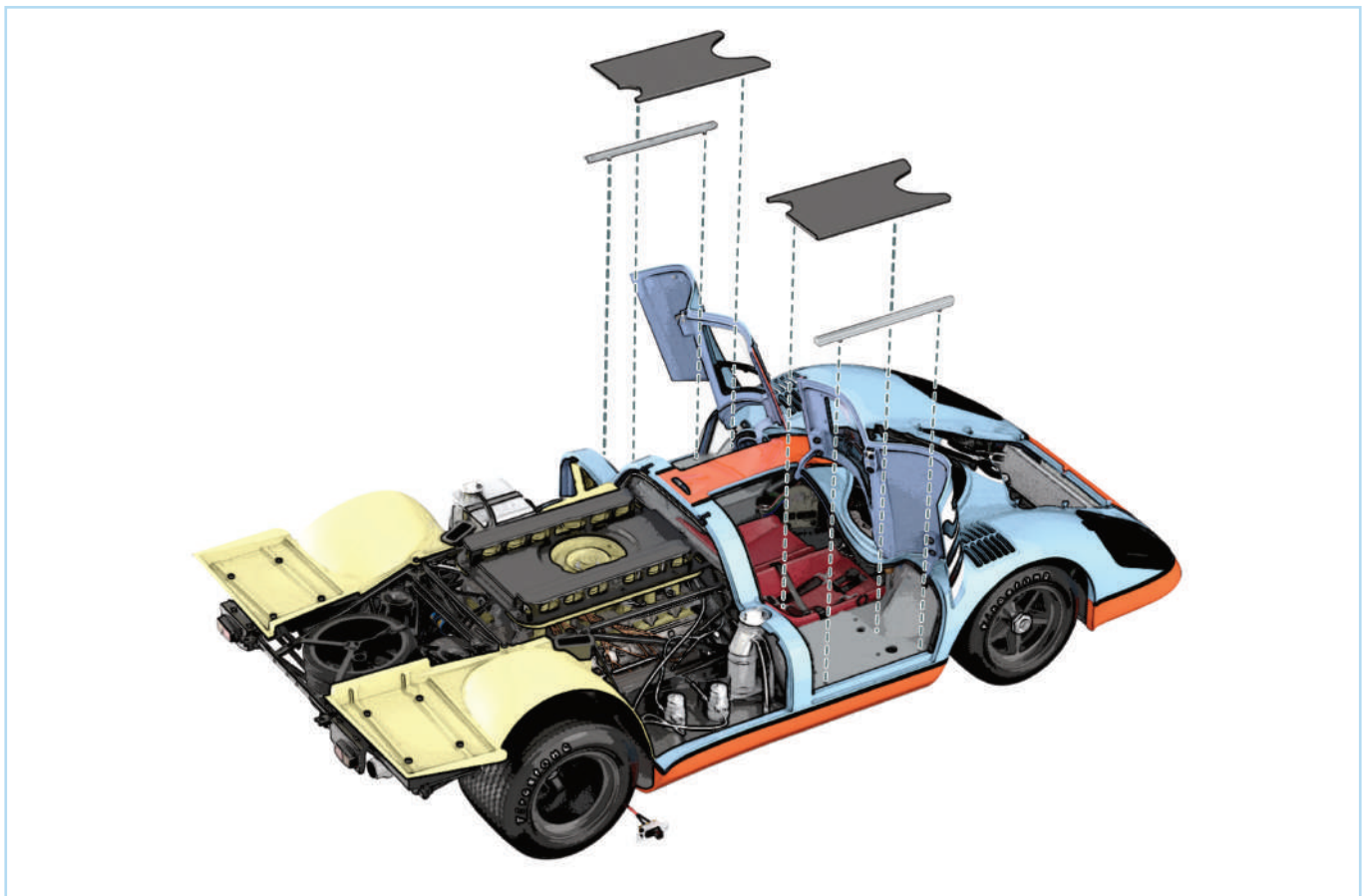

STAGE 98: ADDING THE DOOR SILLS AND TRIMS

You may prefer to fit the door sills and trims at the end of the build, in case any adjustments are needed to the model that require the side fairings to be removed.

STEP 1

Open the right door and align the **right door sill (98B)** with the **right cockpit housing (68B)** as shown. Press the pins of the door sill into the holes of the housing.

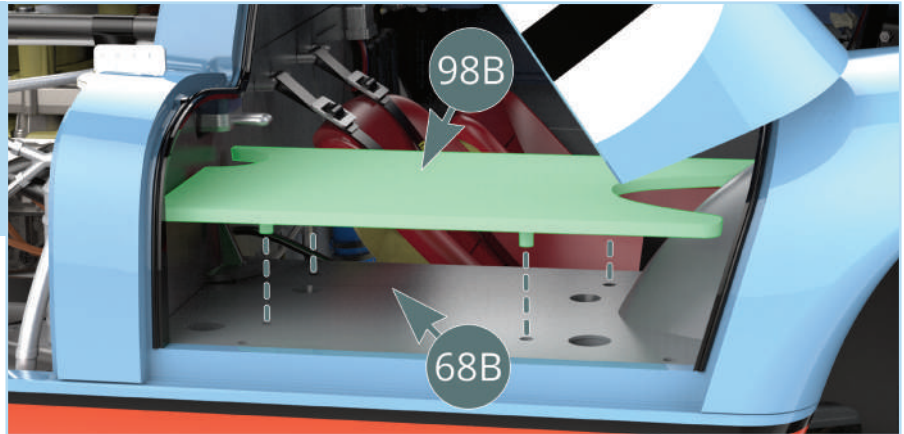

Take the **right door trim (98D)** and push its pins into the holes at the edge of the **right cockpit housing (68B)**.

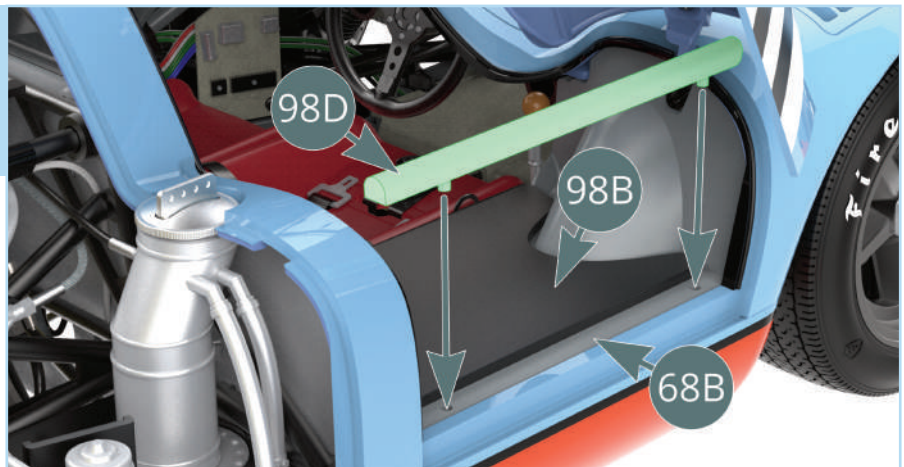

The right door sill and trim have now been fitted onto the cockpit housing. Check the fit is flush, then close the right door.

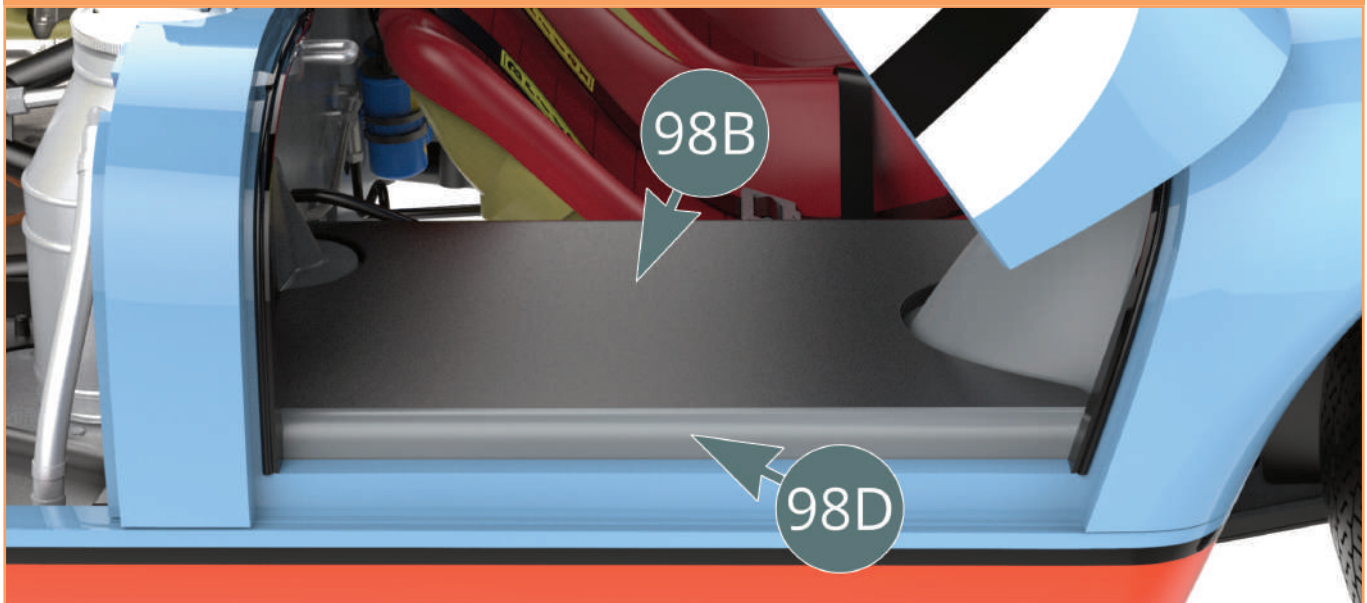

STAGE 98: ADDING THE DOOR SILLS AND TRIMS

STEP 2

Open the left door and fit the **left door sill (98A)**, first tucking it under the **ignition box (56L)** as shown by the green arrow, then pressing its pins into the **left cockpit housing (68A)** as shown by the blue arrow.

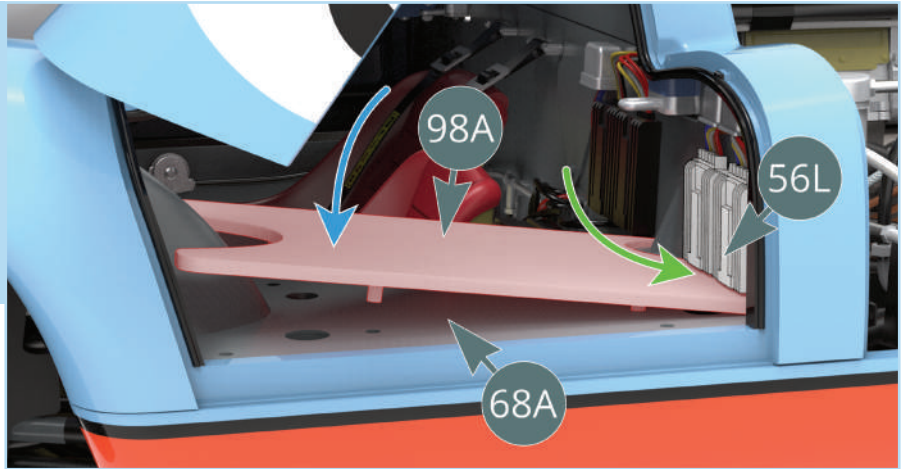

Take the **left door trim (98C)** and push its pins into the holes at the edge of the **left cockpit housing (68A)**.

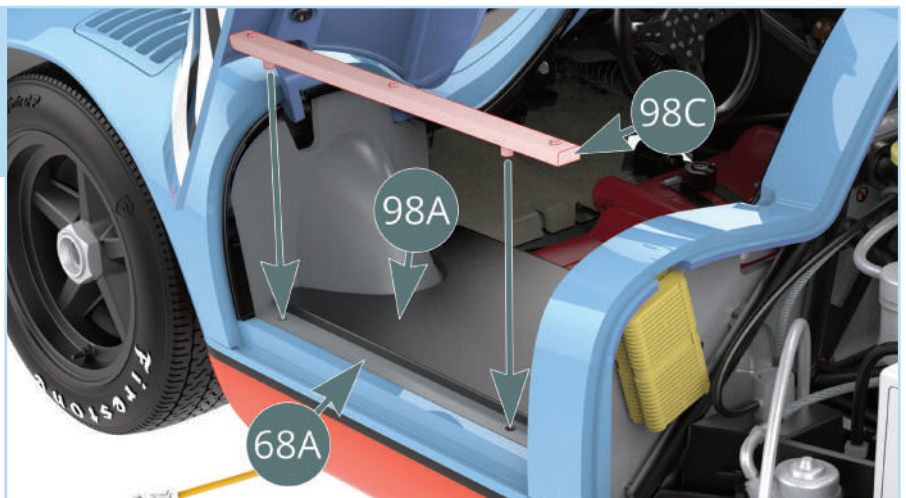

The left door sill and trim have now been fitted onto the cockpit housing. Check the fit is flush, then close the left door.

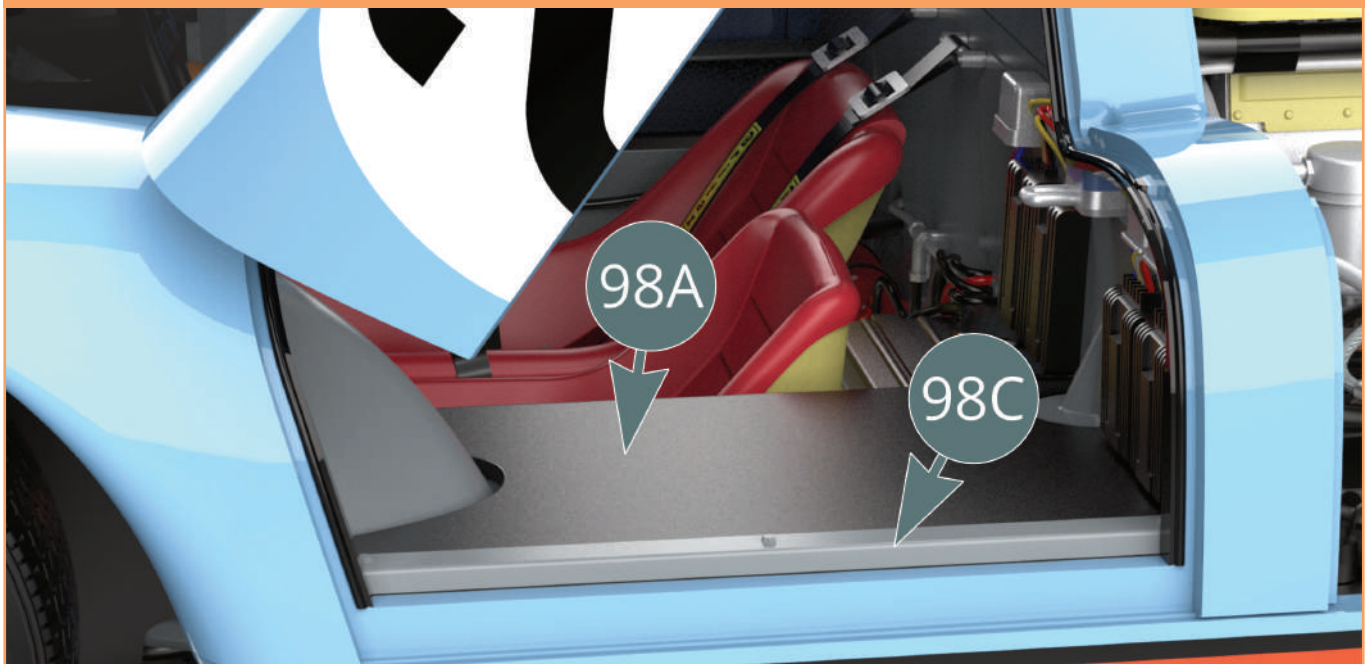

STAGE 98: ADDING THE DOOR SILLS AND TRIMS

STAGE COMPLETE



STAGE 99: FITTING THE SPEAKER, THE SWITCH AND THE BOTTOM PANEL

99A Bottom panel

99B Clamp

99C Decal (x2)

BM Screw 2.0 x 4 mm (x8)

PM Screw 2.0 x 4 mm (x6)

MP Screw 2.0 x 4 mm (x3)

OP Screw 1.7 x 3 mm (x3)



ASSEMBLY DIAGRAM

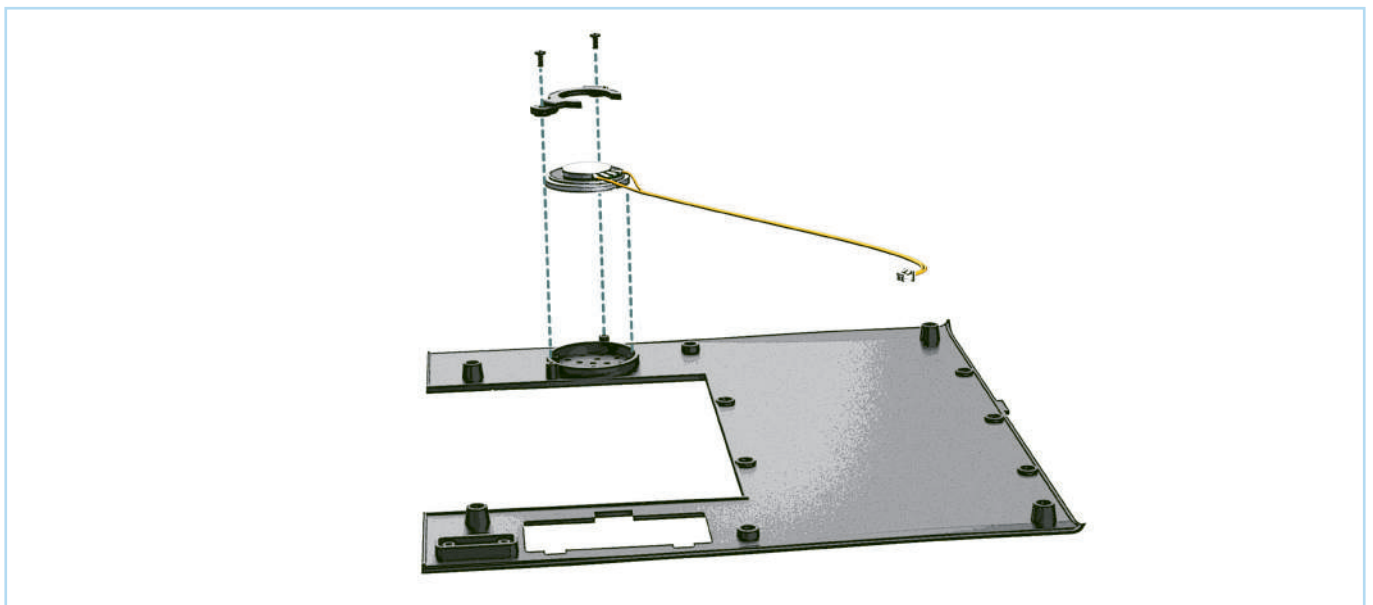

STAGE 99: FITTING THE SPEAKER, THE SWITCH AND THE BOTTOM PANEL

ASSEMBLY DIAGRAM

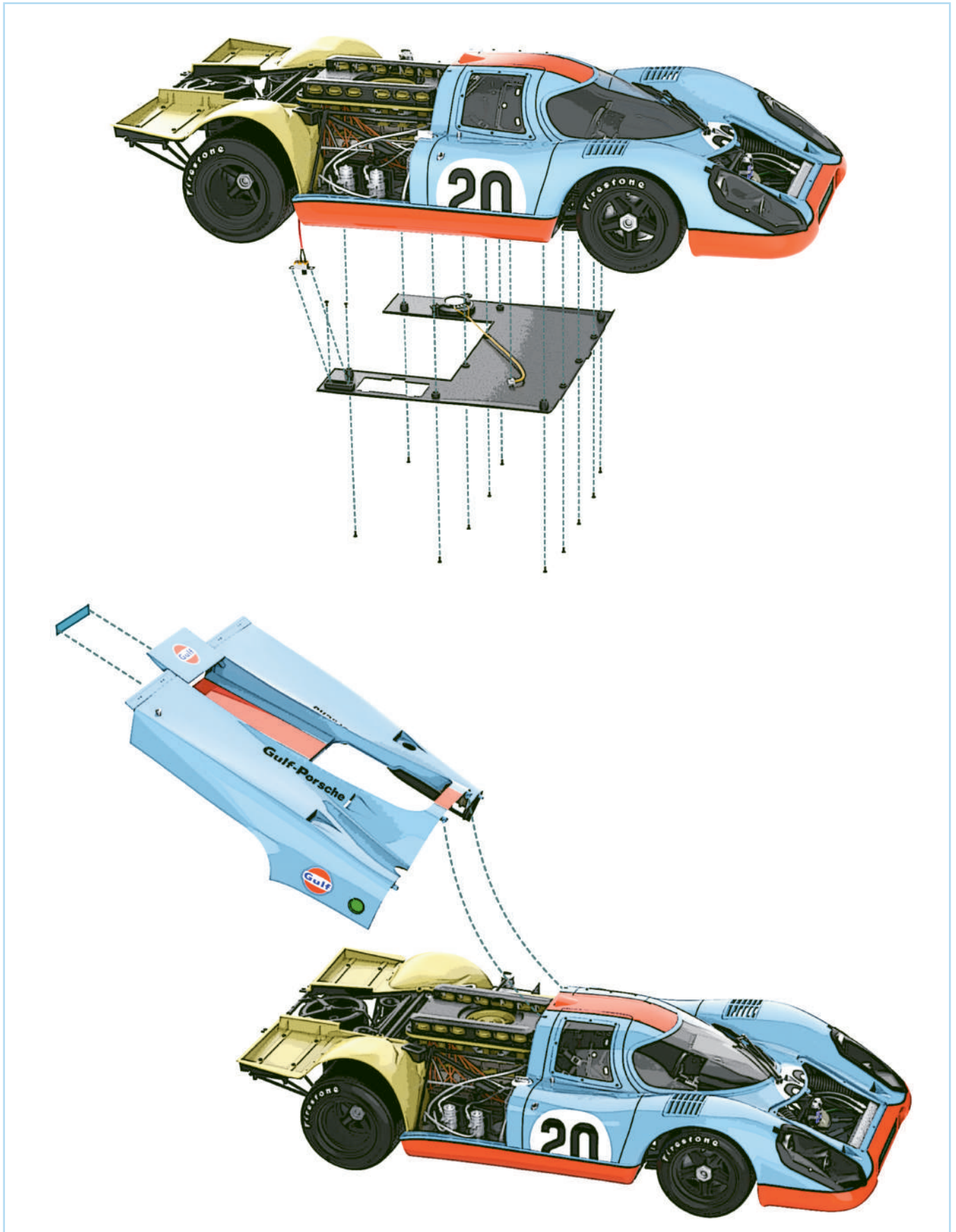

STAGE 99: FITTING THE SPEAKER, THE SWITCH AND THE BOTTOM PANEL

STEP 1

Retrieve the **speaker (34C)** and place into the round recess in the **bottom panel (99A)**, then secure it with the **clamp (99B)** and two **MP** screws as shown. Make sure to align the speaker wires with the opening of the clamp (orange arrows).

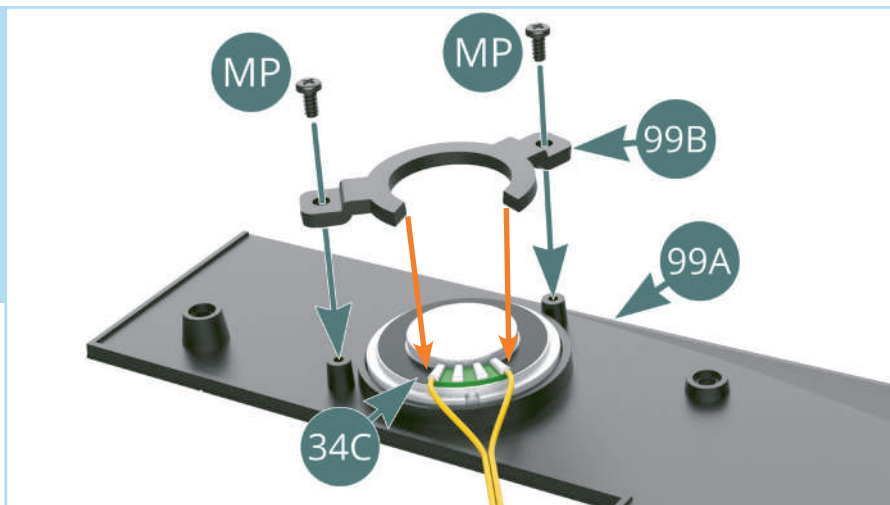

The speaker should look like this once it has been fitted onto the bottom panel.

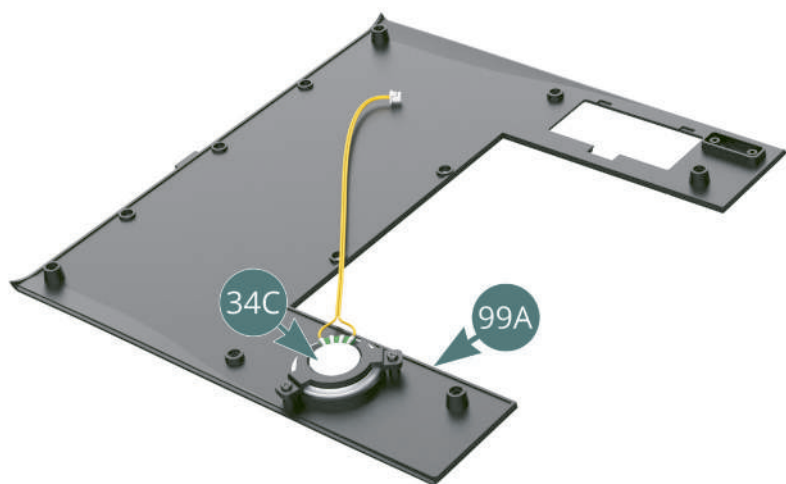

STEP 2

Take the main assembly and carefully turn it upside down. Place the **bottom panel (99A)** onto the upturned model and fit the **switch (33D)** into the shaped recess of the panel as shown. Secure the switch in place using two **OP** screws.

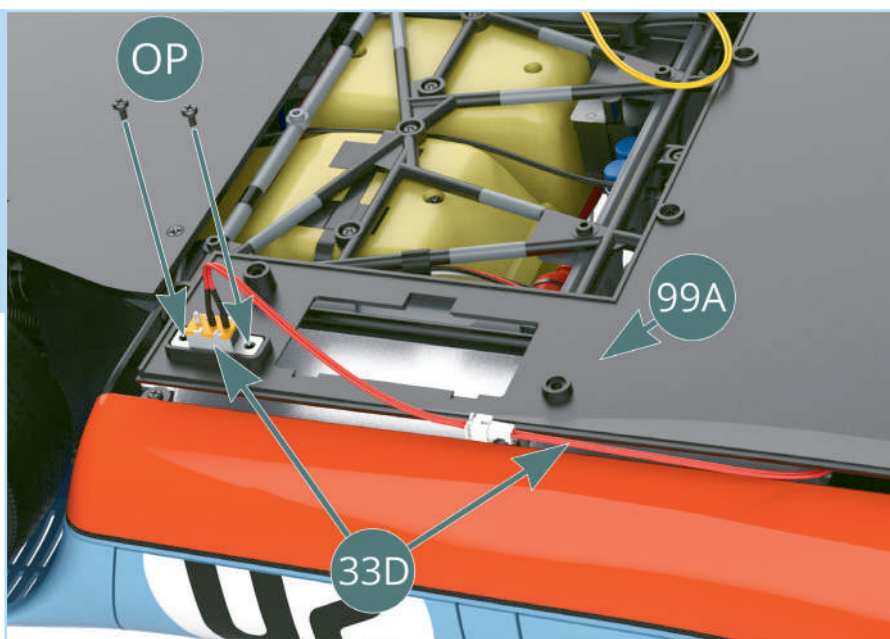

STAGE 99: FITTING THE SPEAKER, THE SWITCH AND THE BOTTOM PANEL

Connect the yellow cables of the **speaker (34C)** and **circuit board (32D)**. Once connected, flip the **bottom panel (99A)** over (see Step 3).

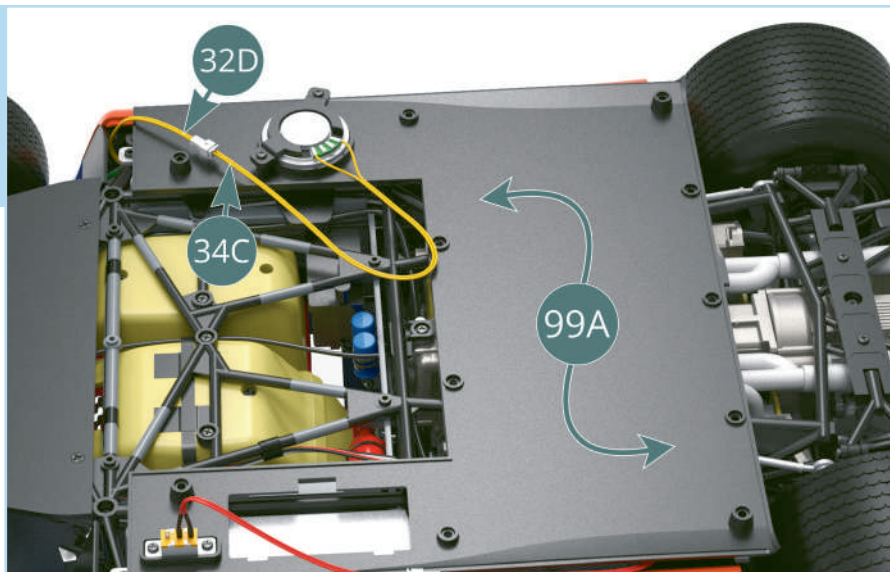

STEP 3

Fit the **bottom panel (99A)** in position as shown, hiding the switch and speaker cables underneath it. Check the panel is aligned correctly and that none of the cables are over any of the screw holes, then fix the middle of it to the **chassis (25A)** using five **PM** screws.

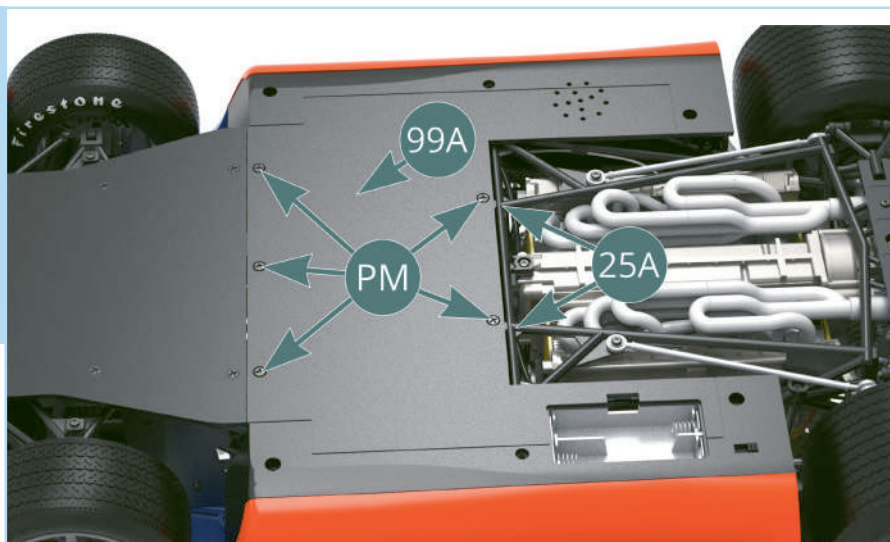

Finish securing the **bottom panel (99A)** to the **chassis (25A)** using six **BM** screws on the left and right sides.

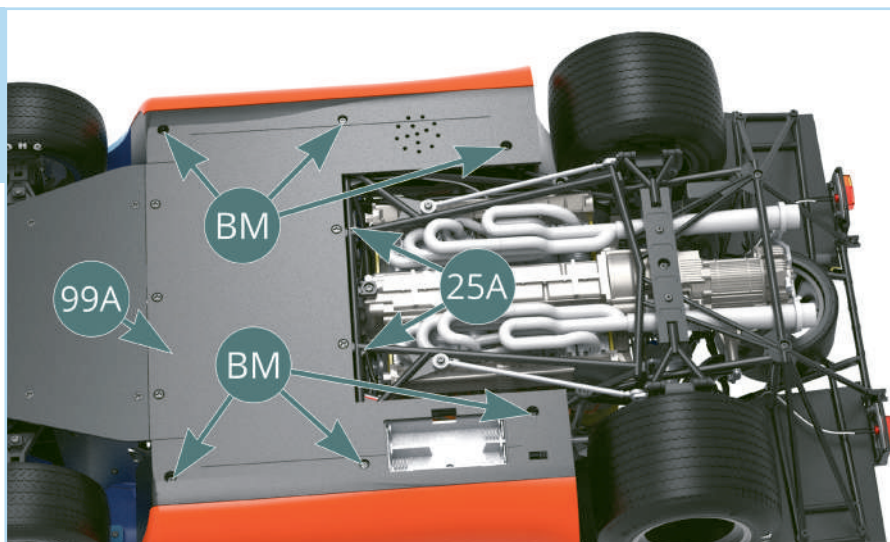

STAGE 99: FITTING THE SPEAKER, THE SWITCH AND THE BOTTOM PANEL

STEP 4

Take one of the **decals (99C)** and retrieve the rear hood assembly. Cut the decal to size, then soak it in water for around 30 seconds. Align the wet decal centrally with the **rear hood panel (93A)** and slide it onto the panel while removing the backing paper as shown. Once it is in place, allow the decal time to dry.

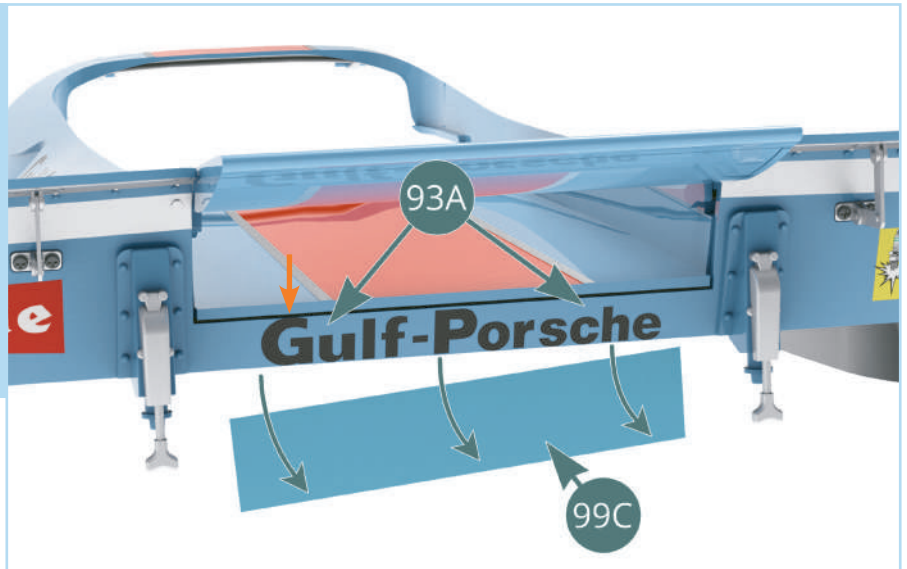

You can use a decal softener to smooth the decal over the bottom edge of the panel if needed. The top of the 'G' in 'Gulf' may need to be pressed into the gap (orange arrow).

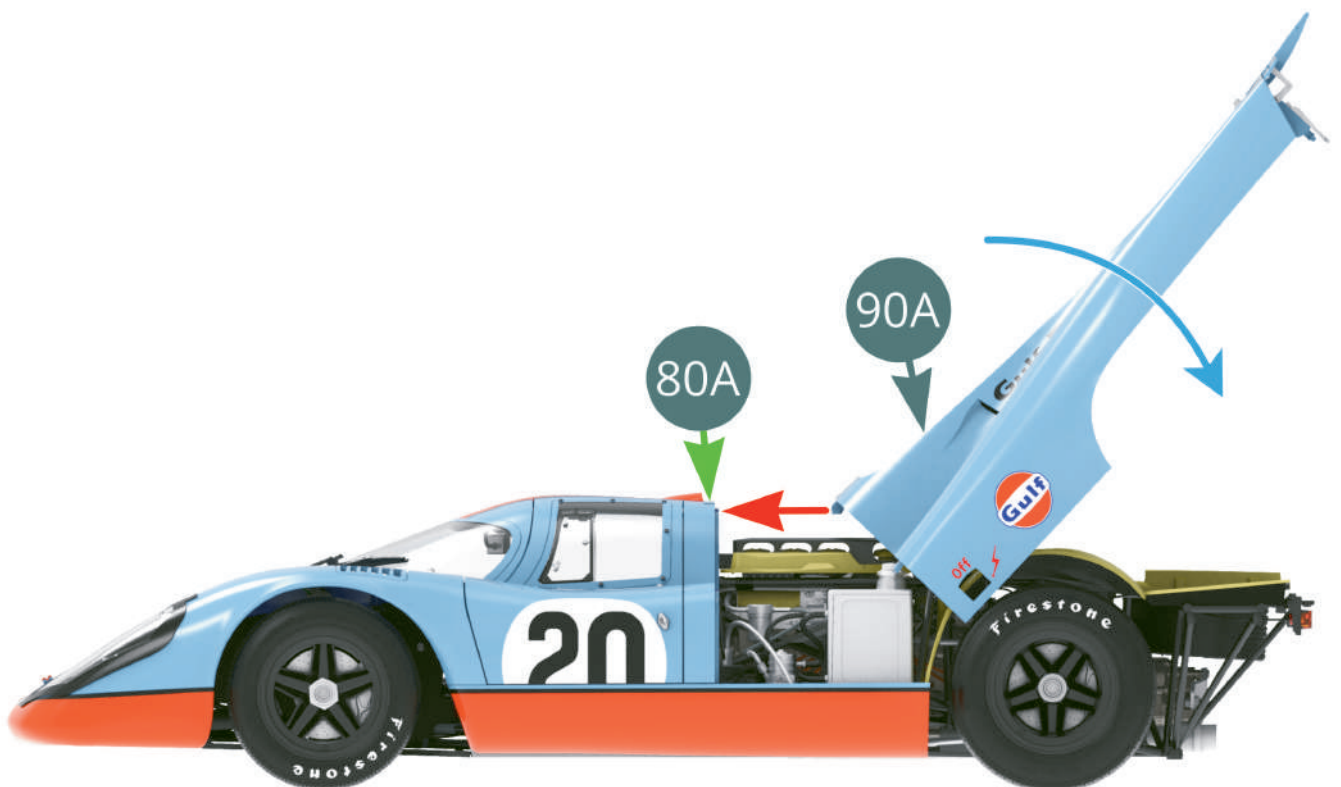

Once the decal is dry, you can fit the rear hood to the model. Remove the transparent tape fitted in Stage 90 if you have not already done so. Align the **rear hood (90A)** with the **front body (80A)** at a 45 degree angle as shown and fit the hood (red arrow). Once in position, lower the hood onto the rear of the model as shown by the blue arrow. Take care not to damage the edges of the front body at the joint (green arrow).

STAGE 99: FITTING THE SPEAKER, THE SWITCH AND THE BOTTOM PANEL

STEP 5

To prop up the **rear hood (90A)**, raise it upwards and unfold the **hood strut (46J and 46K)**, then fit the end into the recess of the **left air duct (91A)** to hold the hood up. Note that the struts may need to be pushed forward to fit into the recess of the air duct. Adjust the screws at the joints (red arrows) to change the alignment until the strut fits into the recess, if needed.

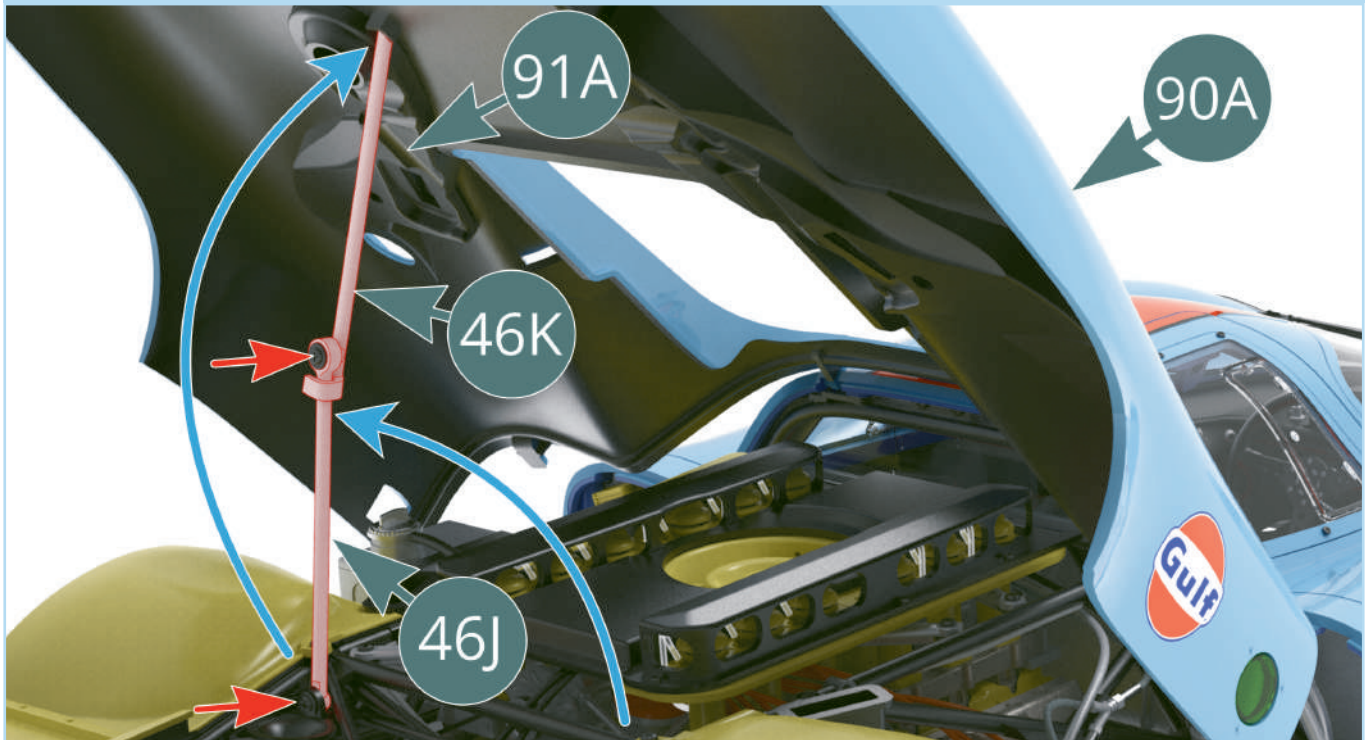

The rear hood has been fitted onto the model and can be held up by the hood struts.

STAGE 99: FITTING THE SPEAKER, THE SWITCH AND THE BOTTOM PANEL

STAGE COMPLETE



STAGE 100: APPLYING THE FINAL DECALS

100A Battery cover

100B Emblem decal (x2)

100C Side number decal (x4)

100D Top number decal (x2)

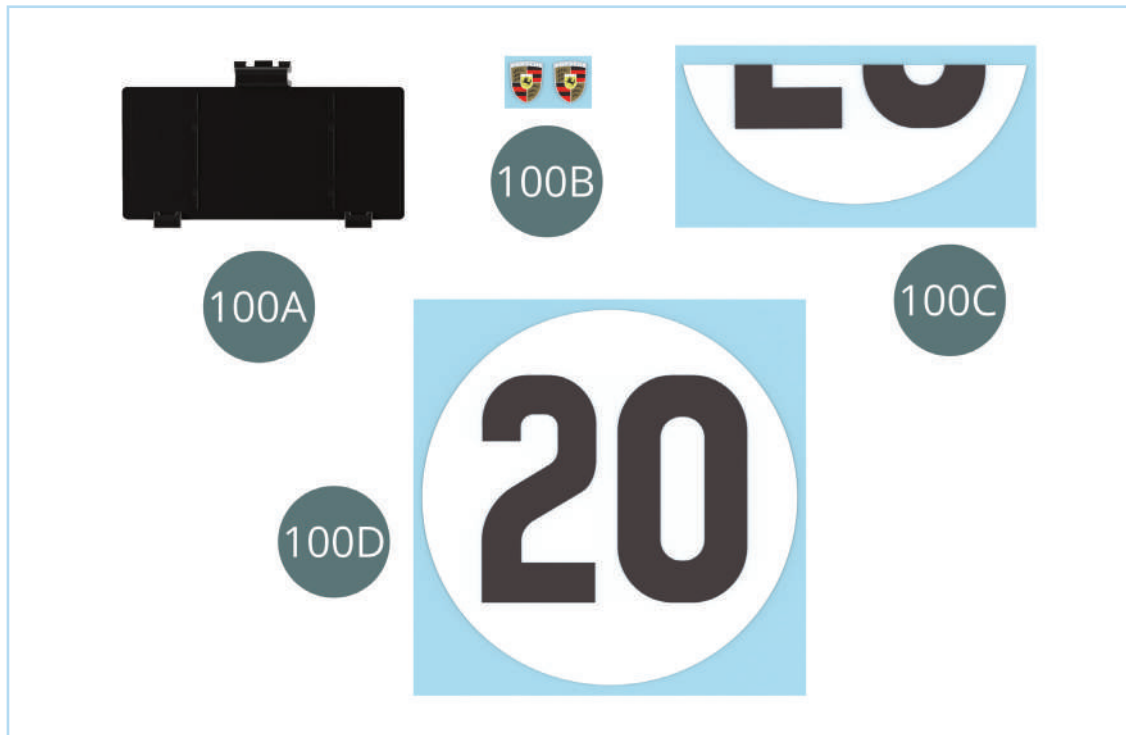

ASSEMBLY DIAGRAM

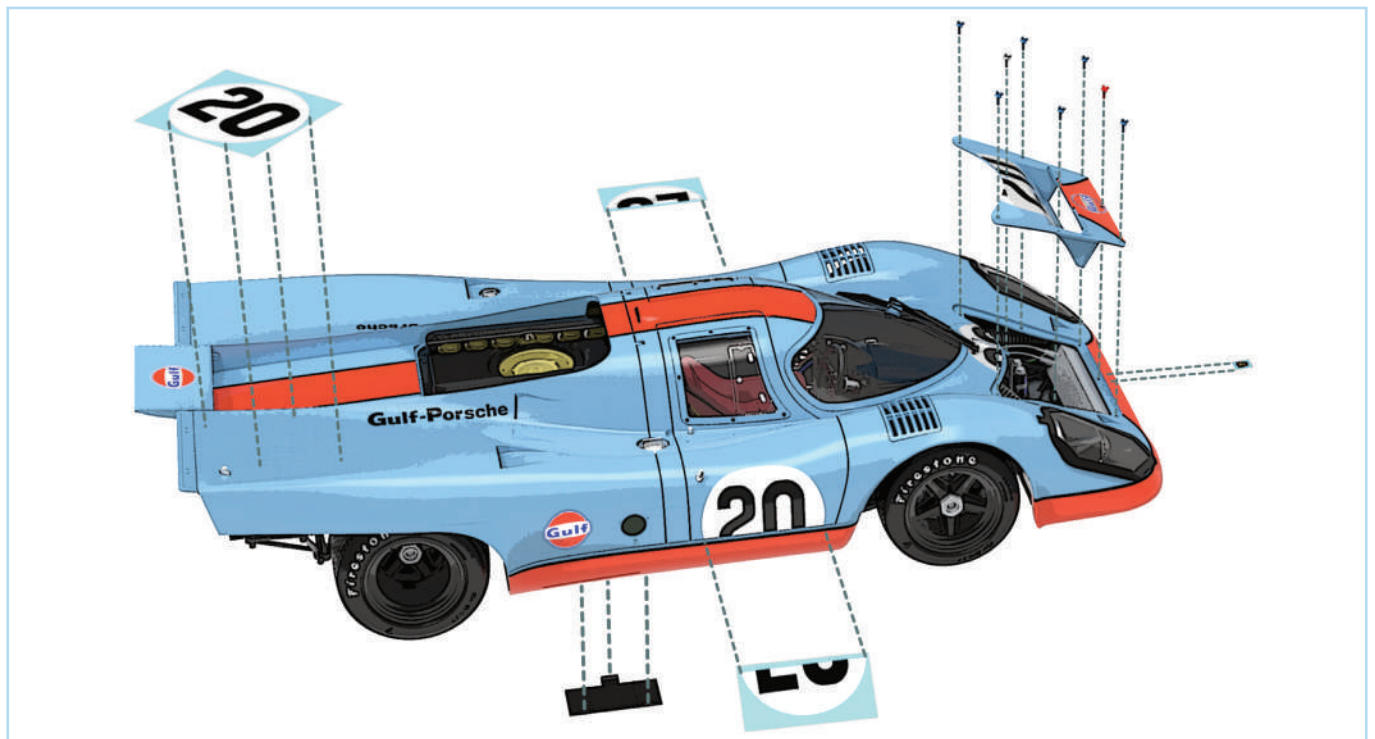

STAGE 100: APPLYING THE FINAL DECALS

STEP 1

Put the **emblem decal (100B)** in water for 30 seconds to soften it. Position the decal on the **front body (80A)** bumper and carefully slide away the backing paper from under it. Make any adjustments to the decal while it is still wet.

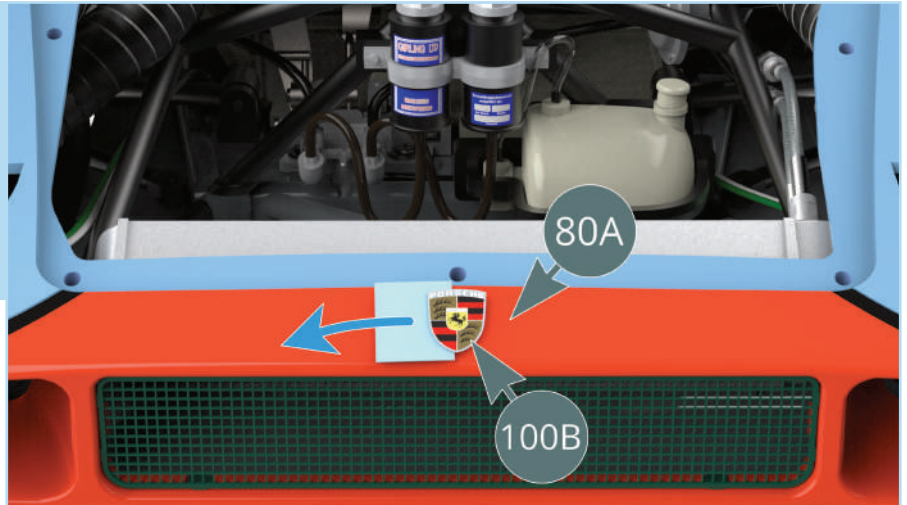

The emblem decal has been added to the front bumper.

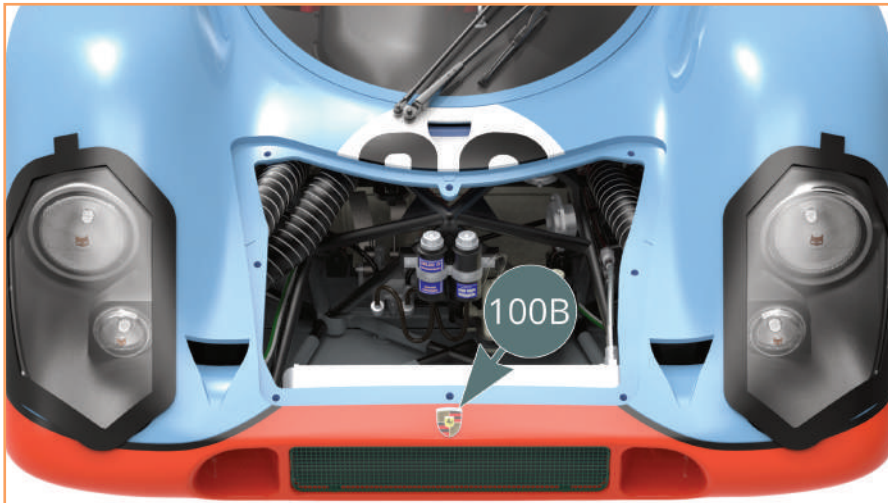

STEP 2

Put the **side number decal (100C)** for in water 30 seconds to soften it, then apply the decal to the **left side fairing (96A)** so it matches the number on the left door as shown. Make any adjustments while it is still wet then soak any excess water away using a cotton pad.

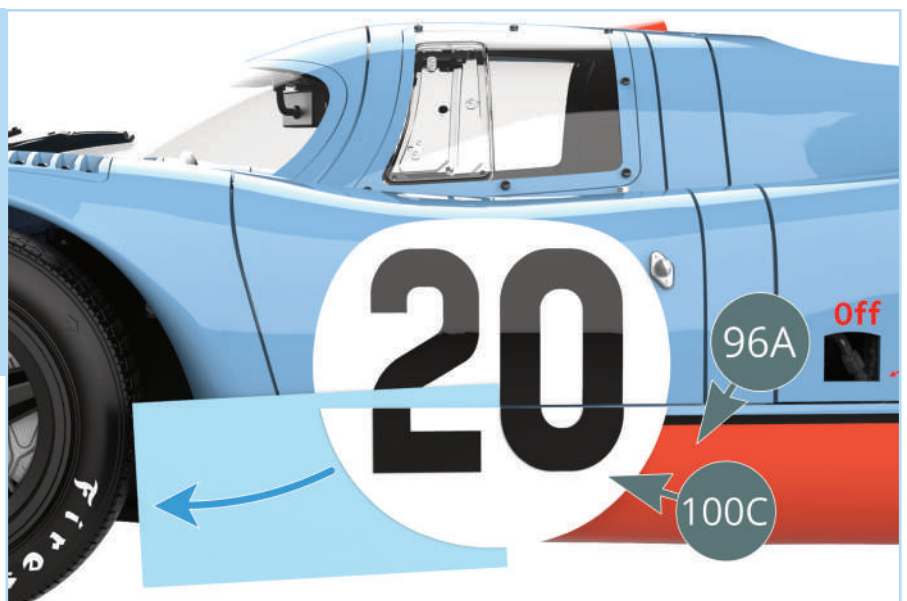

STAGE 100: APPLYING THE FINAL DECALS



The side number decal on the left-hand side should look like this once in place.

STEP 3

Take another **side number decal (100C)** and apply it in the same way to the **right side fairing (97A)**, matching the right door number.



The side number decal on the right-hand side should look like this once in place.

STAGE 100: APPLYING THE FINAL DECALS

STEP 4

Take the **top number decal (100D)** and soak it in water for 30 seconds. Position it on the right side of the **rear hood (90A)** as shown. Make sure the area is clean before applying the decal. Align the decal at a 45 degree angle, parallel with the **hood light (94C)** (orange lines). Once in place, smooth the decal across the surface using a wet brush or decal softener if needed.

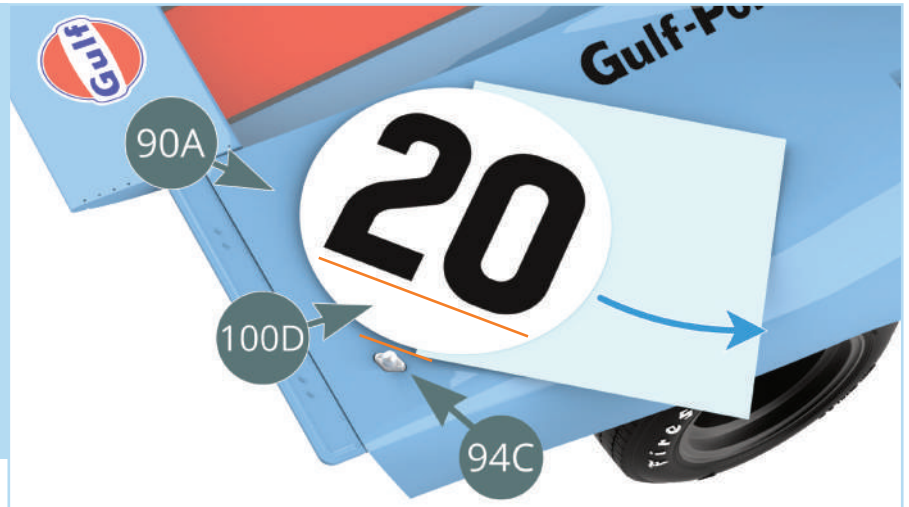

The top decal number has been applied to the rear hood.

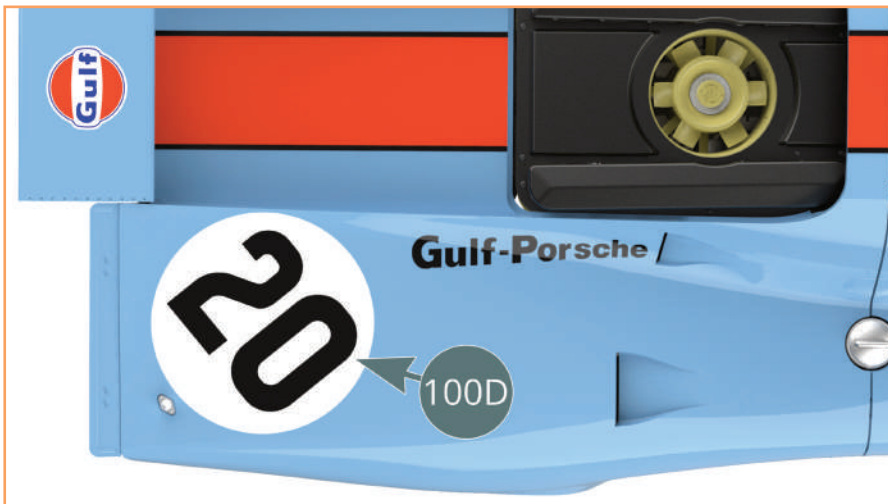

STEP 5

Fit the **hood cover (1B)** onto the **front body (80A)** then fasten it in place with six **blue hood cover locks (82F)**, one **white hood cover lock (82H)** and one **orange hood cover lock (82G)** as shown.

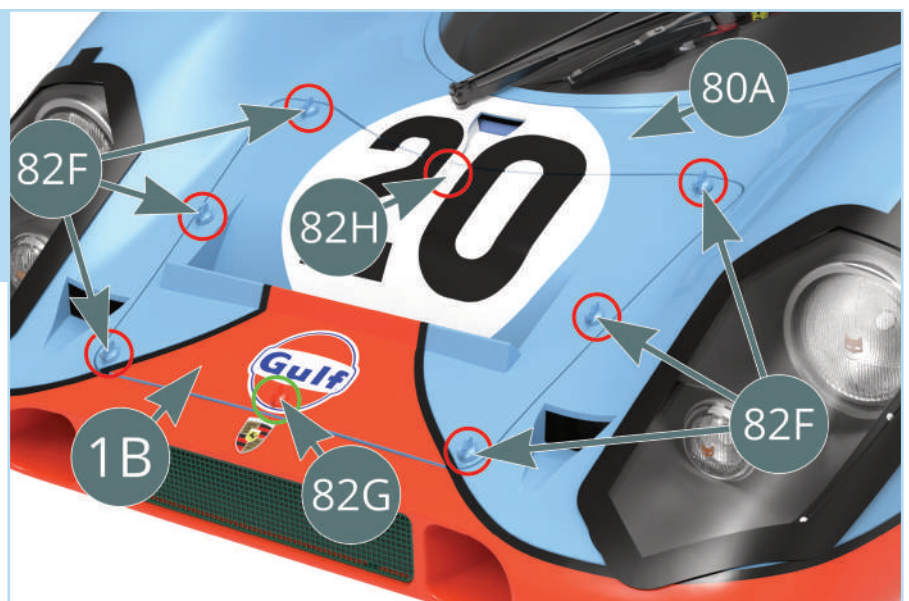

STAGE 100: APPLYING THE FINAL DECALS

Carefully turn the model over and insert two AAA batteries (not supplied) into the compartment and fit the **battery cover (100A)** onto the **bottom panel (99A)**. Push the **switch (33D)** towards the compartment to turn the power on (red arrow).

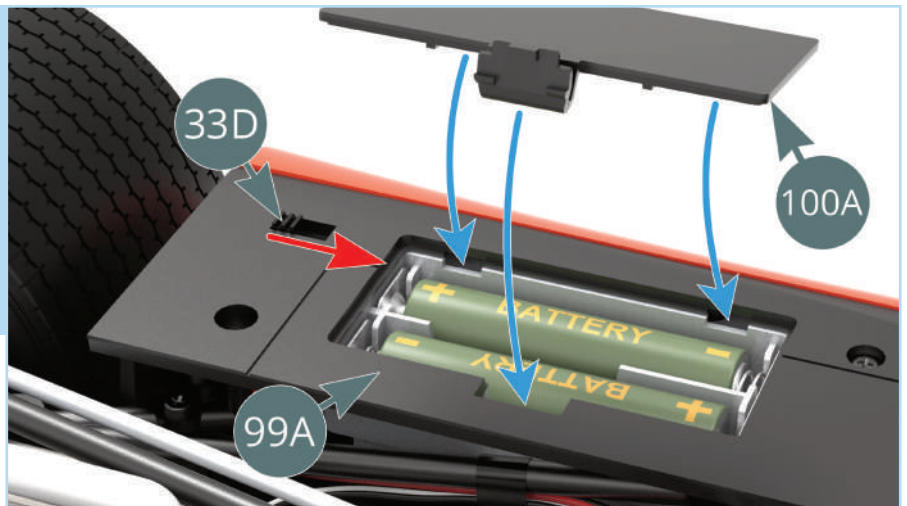

STEP 6

Open the left side door and push the **switch (64L)** marked 'WISCHER'. Check that the lights illuminate as shown in the following three images.



The rear lights will turn on (red arrows).



STAGE 100: APPLYING THE FINAL DECALS

The headlights will turn on (red arrows).



The light located behind the instrument panel illuminates the three dials (red arrows).

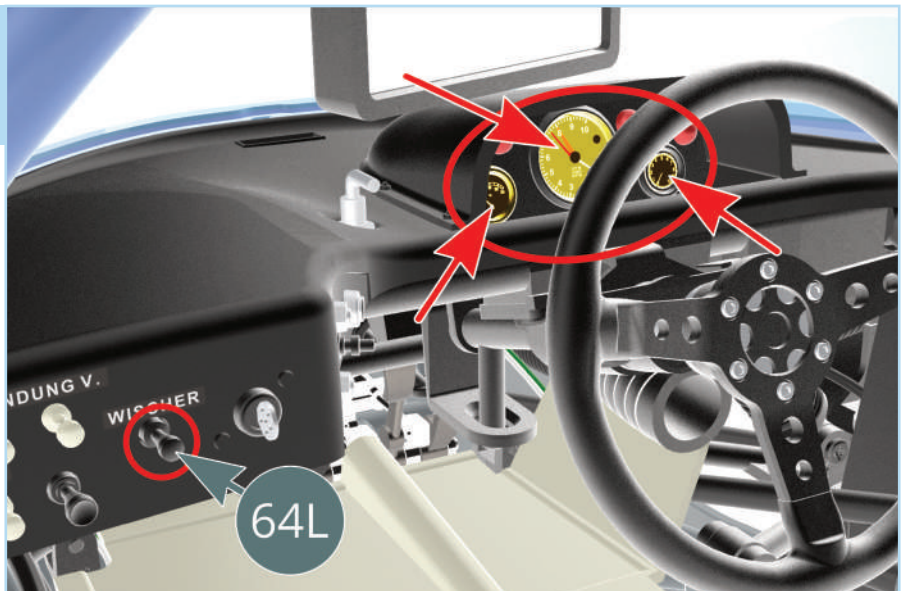

STEP 7

Next press and hold the **brake pedal (26F)** (highlighted green). Use the tip of a pen to help reach the pedal.



STAGE 100: APPLYING THE FINAL DECALS

While the pedal is pushed, the LEDs in the **tail lights (48D and 49D)** will turn on.

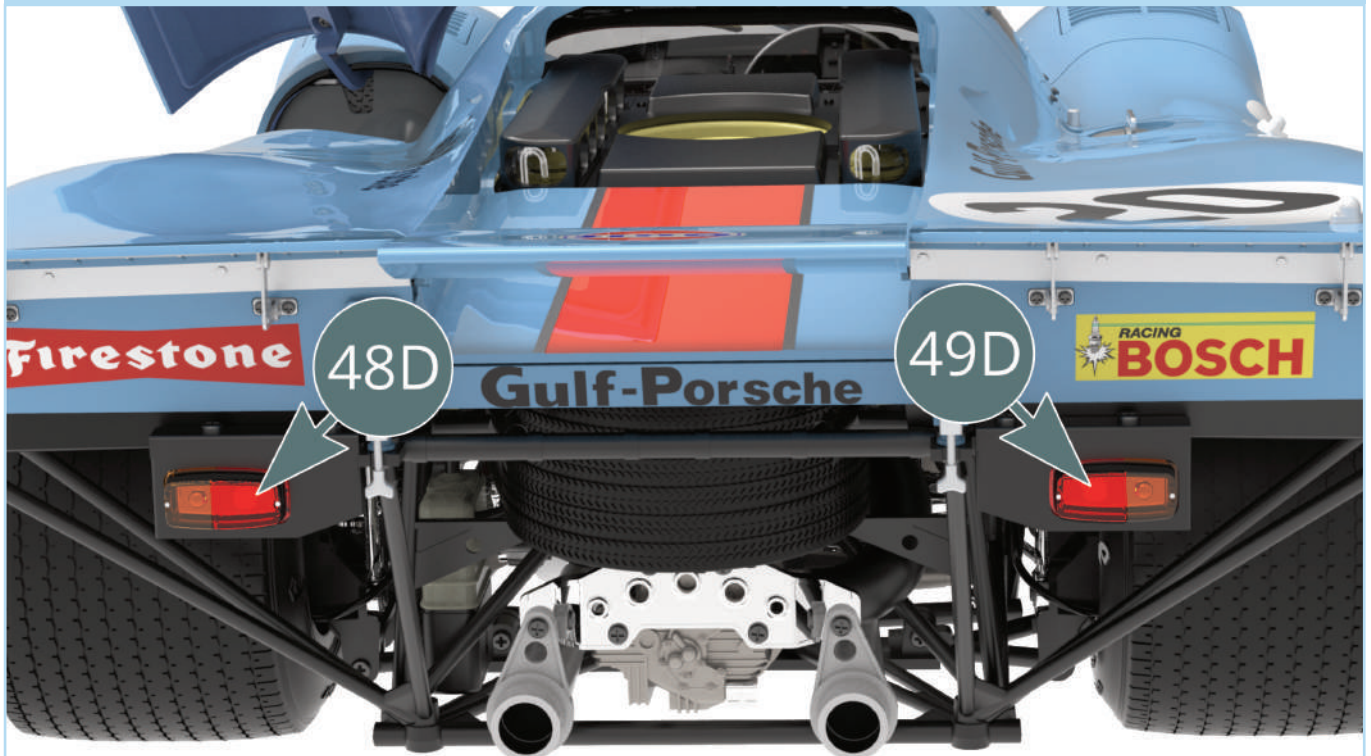

Finally, push the **switch (64L)** marked 'BENZINP. LICHT' to hear the engine sound. Pressing the **switch (64M)** in the middle of the dashboard will sound the horn.



STAGE 100: APPLYING THE FINAL DECALS

STEP 8

If you wish, place the four **model supports (78C)** under the left and right side of the model as shown in the images below. These lift the front wheels from the ground and allow for easier use of the steering wheel's turning function.

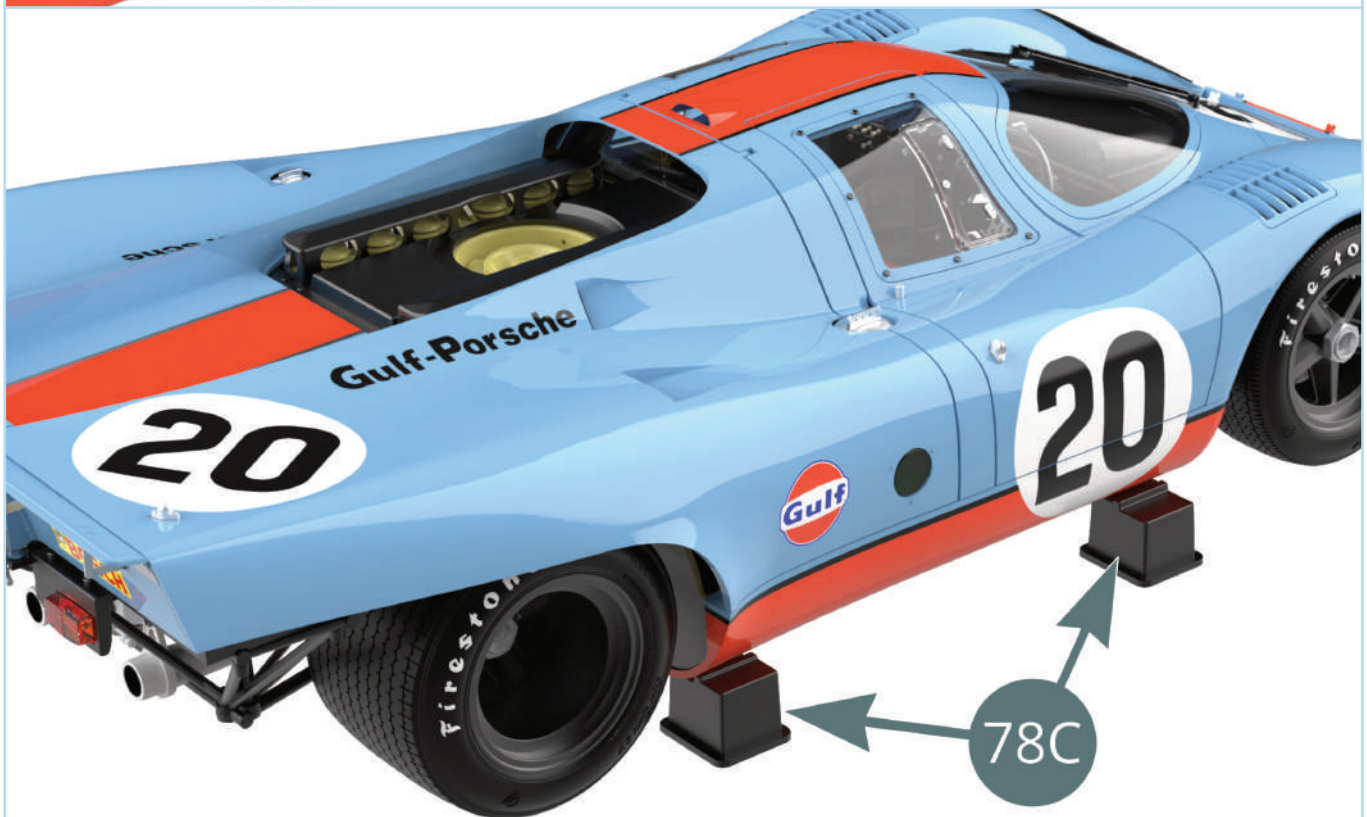
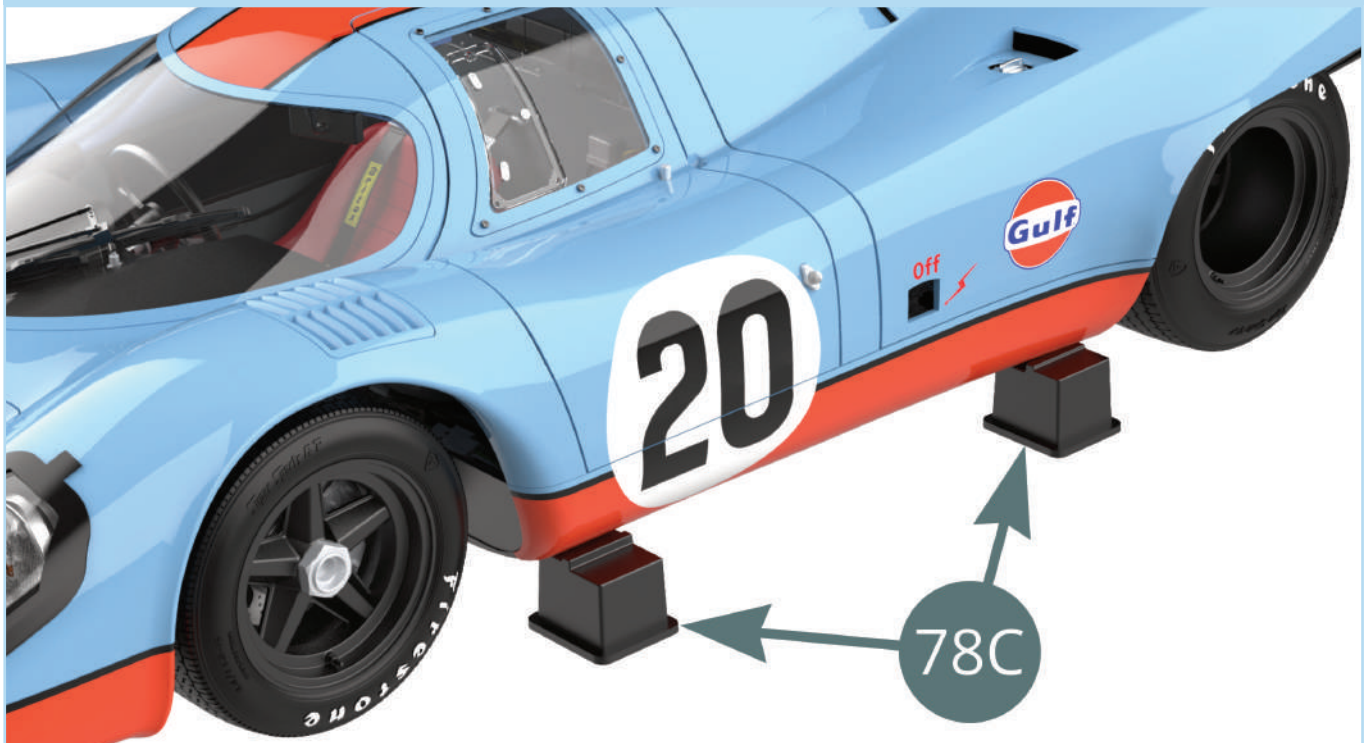

BUILD COMPLETE



Build Complete!

We hope you have enjoyed building your Porsche 917KH.

Don't forget, when you choose your next model the first Pack is absolutely free!

Go to agoramodels.com for more details.

! Warning: to keep your model in pristine condition please keep out of direct sunlight.